



USER MANUAL

WAYFARER 1.2M KA-BAND AUTO-ACQUIRE FLY-AWAY ANTENNA







TABLE OF CONTENTS



Acronyms.....	3
Safety	4
List of Contents.....	6
Case 1	6
Case 2	7
1. Product Overview.....	8
2. System Overview	8
3. Hardware	9
3.1 Case Dimensions.....	9
3.2 Antenna Dimensions.....	10
4. Electrical	12
4.1 Power Supply.....	12
4.2 Antenna Control Unit.....	12
4.3 Antenna Control Unit.....	13
5. Quick Start	15
5.1 Antenna Assembly	15
5.2 Cable Connection	20
5.3 Auto-Acquire.....	22
6. System Maintenance.....	26
7. Factory Reset.....	26
8. Technical Specification.....	27
Appendix A – Magnetic Declination Map	28

Acronyms

ACU	Antenna Control Unit
AZ	Azimuth
BUC	Block Upconverter
CCW	Counter clockwise
CW	Clockwise
EL	Elevation
IFL	Interfacility Link
LNB	Low-noise Block Downconverter
M&C	Monitor and Control
OMT	Orthomode Transducer
POL	Polarization

Safety

<p>Caution</p> 	<p>Grounding the Terminal</p> <p>Ground the system with a grounding conductor in accordance to national and local electrical codes.</p>
<p>Danger</p> 	<p>FCC Radio Frequency Exposure Information for Mobile Transmitting Devices</p> <p>When the power is on, do not stand within the line of sight of the terminal to the satellite and maintain an off-axis clearance distance of a full reflector diameter length from the centre of the beam.</p>
<p>Danger</p> 	<p>Electrical Hazards in Wet and Windy Conditions</p> <p>While the terminal is designed for outdoor use (e.g. optional waterproof power supply), observe the following safety precautions during windy and wet weather conditions. Some steps may not apply depending on the BUC configuration.</p> <ol style="list-style-type: none"> 1. Check cable connectors and power cords for damage or tears. Replace cables and cords as needed. 2. Disconnect the terminal from its power source before you move it. 3. Disconnect the terminal from its power source if you suspect a power malfunction
<p>Warning</p> 	<p>Hot Surfaces</p> <p>When transmitting, do not touch the BUC as it may result in burns or injury.</p>
<p>Danger</p> 	<p>Hazards of Microwave Radiation in Electromagnetic Fields</p> <p>When the power is on, the area directly in front of the antenna is an Area of Restricted Occupancy. Observe the following safety precautions:</p> <ol style="list-style-type: none"> 1. Limit human exposure time to the area directly in front of the main antenna assembly. 2. Never place any part of your body between the antenna and the Feed Horn assembly. 3. Never place any part of your body in line with the direction of the antenna transmission path. 4. Locate the terminal as far as possible from ungrounded metal.

<p>Danger</p> 	<p>Dielectric Heating</p> <p>Dielectric heating is the heating of an insulating material caused by placing it in a high frequency electric field. When a human enters a Radio Frequency (RF) field, the body acts as dielectric. If the power in the RF field exceeds 10 milliwatts per centimetre, the individual will have a noticeable rise in body temperature.</p> <p>The severity of burns may vary from minor to major. Burns or other damage may result in long term injury or even death.</p> <p>The vital organs of the body are highly susceptible to dielectric heating.</p> <p>The eyes are also highly susceptible to dielectric heating. Do not look directly into devices radiating RF energy.</p> <p>You must not stand directly in the path of RF radiating devices</p>
<p>Warning</p> 	<p>Unintentional Radio Interference</p> <p>This equipment generates, uses, and radiates radio frequency energy. If you install and use the device according to the instruction manual, the device will not cause harmful interference to radio communications.</p> <p>If you operate the device in a residential area, it is likely to cause harmful interference to radio communications; you will correct the interference at your own expense.</p>
<p>Warning</p> 	<p>Changes or Modifications to Equipment</p> <p>Changes or modifications to this equipment, not expressly approved by the manufacturer could void the user's authority to operate the equipment.</p> <p>Accessories and Devices</p> <p>Use of non-approved accessories or devices may lead to a degradation in performance, damage to equipment, or potential hazards</p> <p>Servicing the Equipment</p> <p>Do not service the equipment alone unless another person is present to administer first-aid</p>

List of Contents

Case 1

COMPONENTS	QUANTITY
Pedestal Assembly (ODU)	1
Antenna Power Supply	1
Sensor Cable	1
Remote Cable	1
Modem Cable (Optional)	1
IFL Cable (Optional)	1

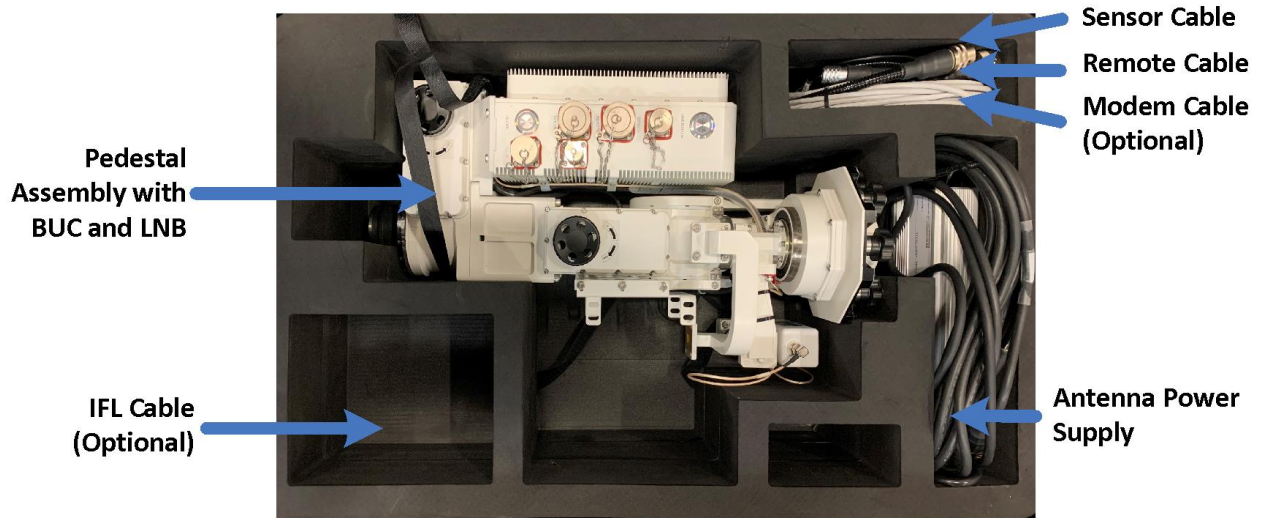

Case 2

COMPONENTS	QUANTITY
Reflector Petals	8
Feed Horn	1
Leg Assembly	1
Footpad	3
Firmware Upgrade Cable	1
BUC Power Supply (Optional)	1

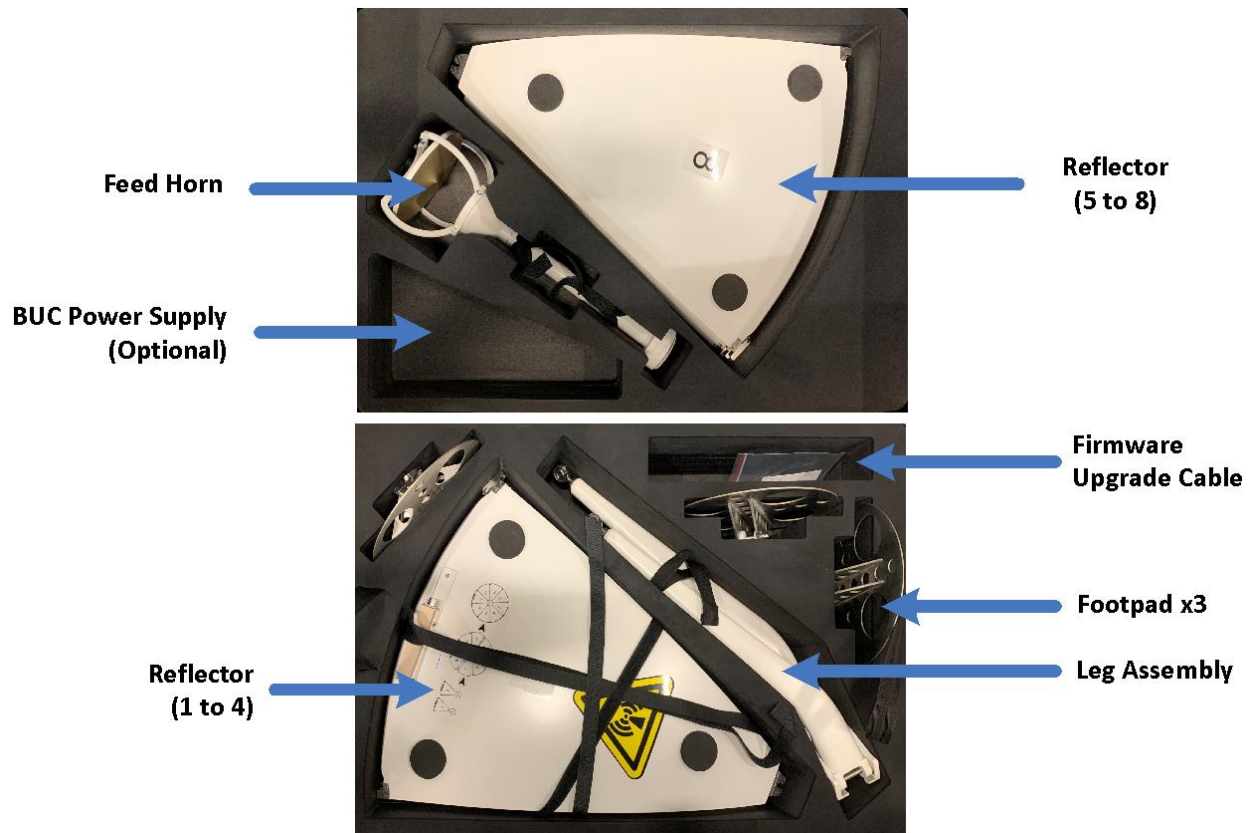

1. Product Overview

The Norsat WAYFARER is an industrial strength transportable satellite communication system built strong for the most demanding users working with the most challenging applications and environments. The WAYFARER is fully automated, integrated, and versatile enough for deployment virtually anywhere, including mobile field offices, field vehicles, or directly on the ground. A complete satellite solution, the WAYFARER includes everything to meet your communication needs.

2. System Overview

The system consists of an antenna control unit, antenna drive unit, I/O unit, GPS module, beacon receiver, DVB receiver, compass, inclinometer and other instruments.

Refer to the images below for the system block diagram using an OpenAMIP and Non-OpenAMIP implementation. Refer to the LinkControl user manual for more information about OpenAMIP.

OpenAMIP System Block Diagram

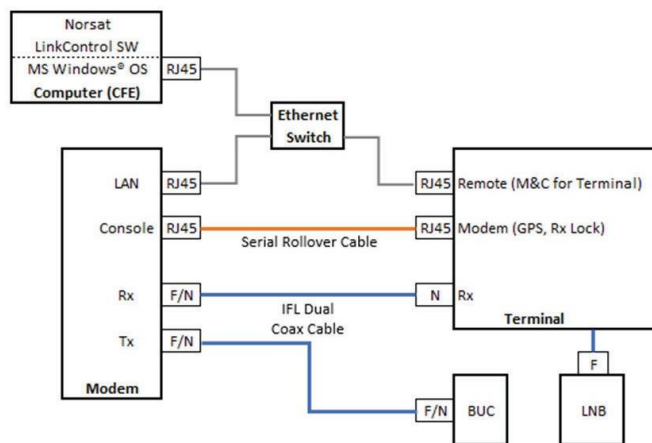

Non-OpenAMIP System Block Diagram

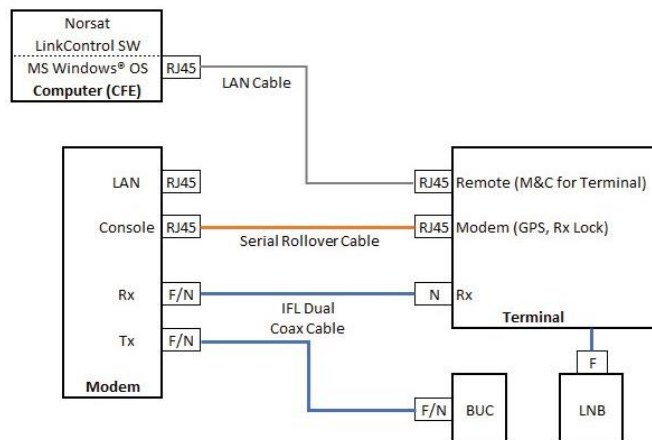

3. Hardware

3.1 Case Dimensions

CASE	MODEL	DIMENSIONS
1 (Pedestal)	Pelican iM2950	79.5 x 51.8 x 31 cm
2 (Tripod, Feed, Reflector)	Pelican iM3075	84.6 x 62 x 49 cm



Case 1



Case 2

3.2 Antenna Dimensions

All dimensions are in millimeters.

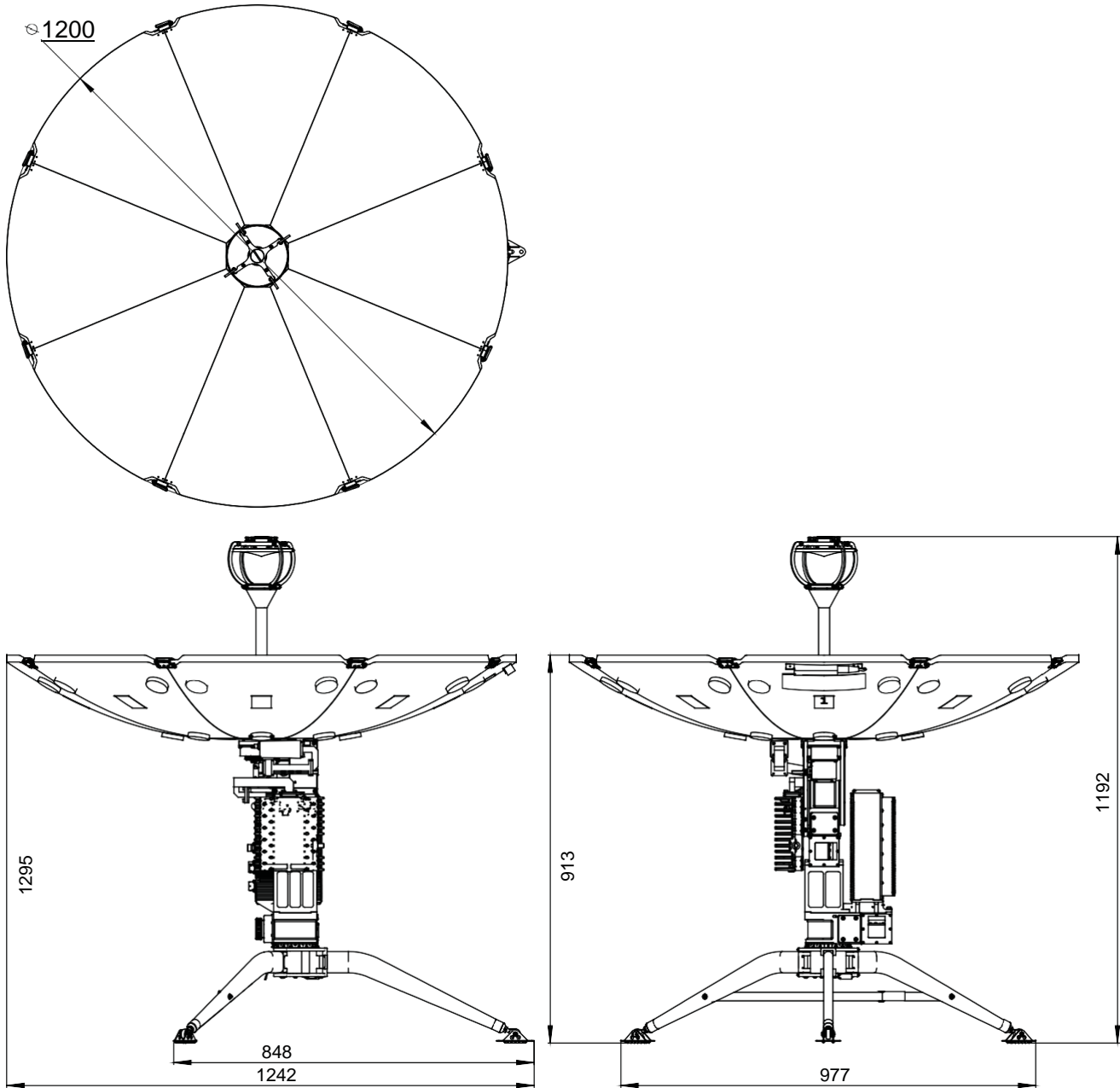

All dimensions are in millimeters.

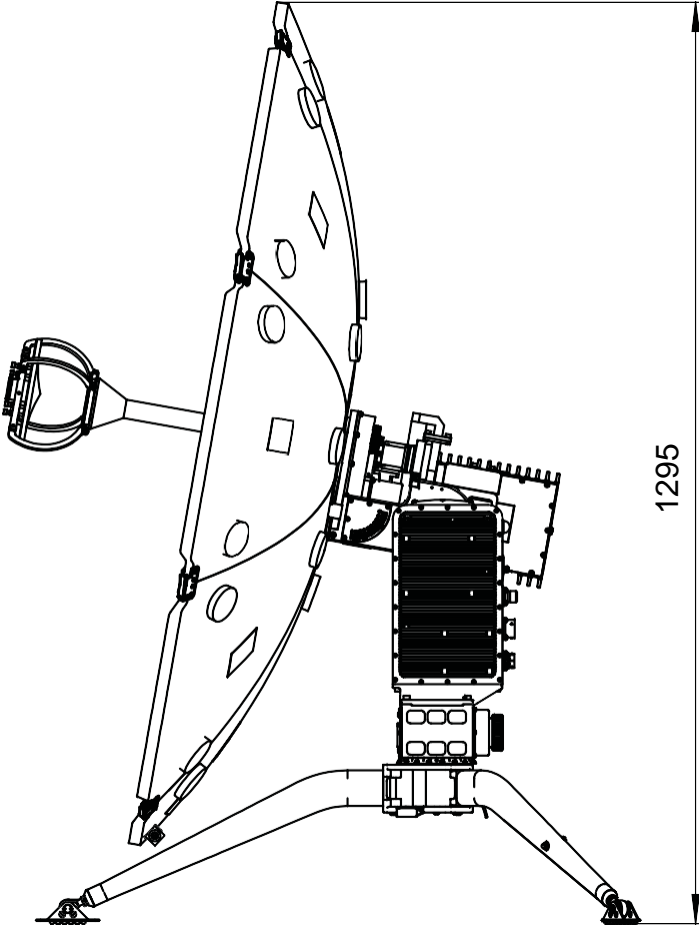

4. Electrical

4.1 Power Supply

COMPONENT	REQUIREMENT
Antenna Power Supply	Antenna is powered by a power supply that requires 110-240V AC input
LNB	LNB is powered by 15V DC from ACU through Rx cable
BUC	BUC up to 8W can be powered by 24V DC from modem through IFL cable. 20W and 40W ATOM BUC requires 48V DC input from at least 300W power supply

4.2 Antenna Control Unit

Antenna Control Unit is integrated with the pedestal

All ports and switches are installed onto the ACU, as shown below:

PORT	DESCRIPTION
Sensor	Compass signal input from compass on reflector petal 1
One Button	<p>One button control for antenna resetting, satellite pointing, stowing and stopping motion without the handheld device</p> <ol style="list-style-type: none"> 1. Press button and release after one beep, antenna will reset and verify limit switches 2. Press button and release after two beeps, antenna will start pointing to the last satellite it has successfully acquired 3. Press button and release after three beeps, antenna will stow
Remote	RJ45 ethernet port for LinkControl Client
Modem	RJ45 port for modem
On/Off	Power switch for antenna
Rx	Rx signal output from LNB
DC IN	24V DC power input, to be connected to supplied AC power adapter

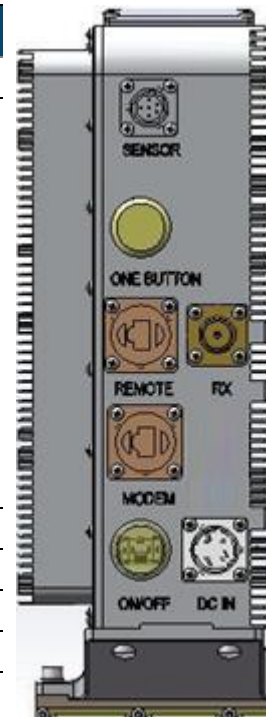

4.3 Antenna Control Unit

4.3.1 Azimuth and Elevation Modules

Azimuth module consists of azimuth motor, planetary gearbox, worm gearbox, internal gear and azimuth base. The azimuth movement is mechanically self-locking and can be manually controlled through the lower knob on pedestal. Elevation module consists of: Elevation motor, elevation gearbox and elevation base. The motor incorporates electromagnetic braking. Thus, the elevation angle can be maintained in case of power outage. The elevation angle can be manually controlled through the upper knob on pedestal.

4.3.2 Polarization Module

The polarization module consists of polarization motor, feed assembly, gearbox, duplexer, filter and LNB. The polarization module's main functionality is to adjust the polarization angle and isolate the Tx/Rx signal.

The installation of polarization module is optimized from factory to ensure best performance. Should the polarization module be removed, please mark the location of mounting screws on the slot beforehand.

4.3.3 GPS Receiver

GPS module is installed inside the ACU. GPS lock/ not locked indicator can be observed through the plastic cap on top of the ACU. When the indicator is blinking, the GPS is not locked and when indicator is on, the GPS is locked. GPS Lock/ Not locked and latitude and longitude information are showing in real time LinkControl.

4.3.4 3D Compass/Inclinometer

The compass/ inclinometer is mounted onto the reflector petal 1. The device provides heading and elevation angle to ACU. The heading information is updated upon system reset.

4.3.5 Modem Port

The modem port is designed to be integrated with iDirect Modems. The ACU outputs the GPS signal

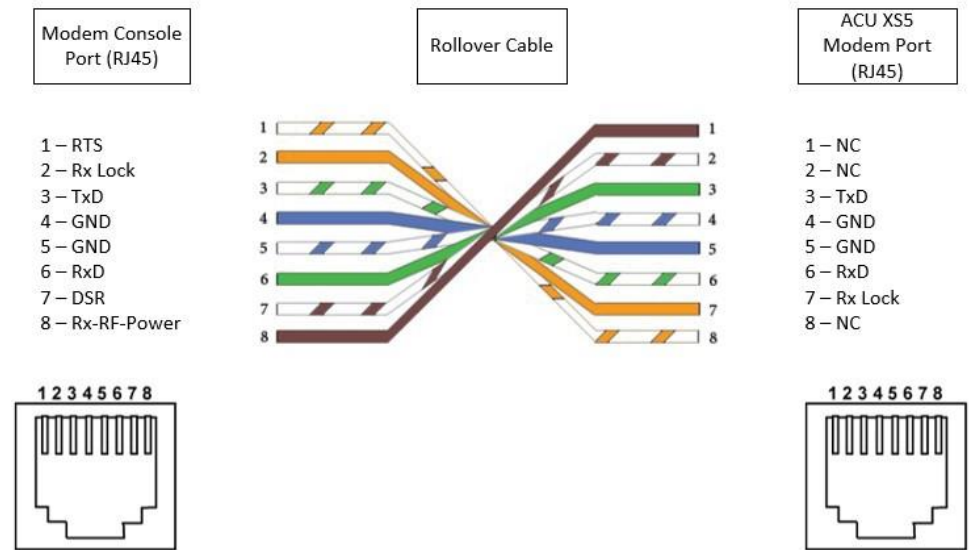

4.3.6 Adjustment Knobs

Adjustment knobs for Azimuth and Elevation are available on the antenna for use in case of emergency.

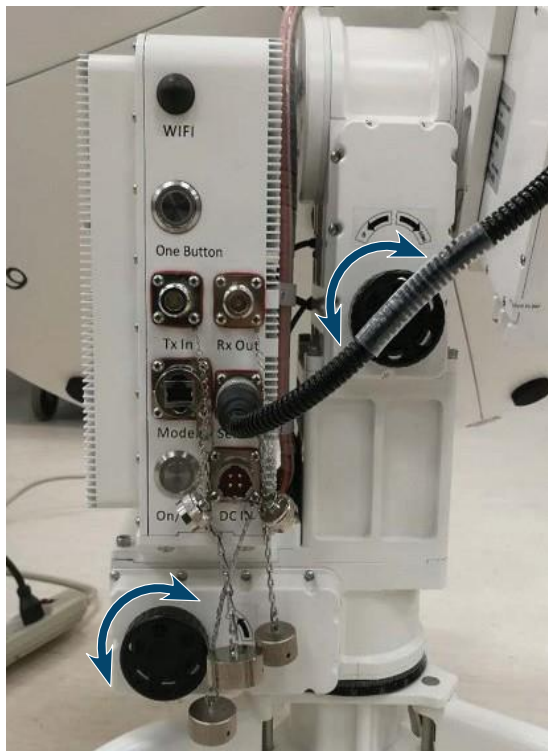

5. Quick Start

5.1 Antenna Assembly

1. Pull out the tripod.



2. Unfold the legs to limit and buckle up the strap so that the legs are sturdy.
3. Take out the footpads and mount them onto the tripod by following the instructions below:



Release the pin from the Footpad



Insert the Leg Joint into the Footpad from top

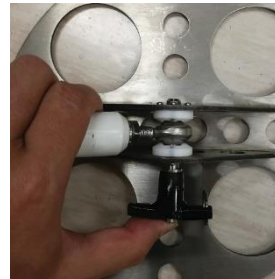

Push in the button on the pin and insert from side



Ensure pin goes through the mounting hole

4. Pull up the metal latch on the side of the tripod.

Note: Ensure the latch remains pulled up until the pedestal is inserted into the tripod.

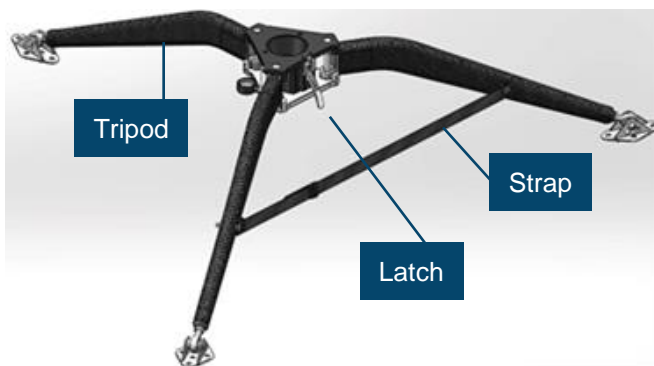

5. If this is a high wind condition, stake down or add ballast weight to the tripod legs.

6. Take out the pedestal.
7. Orientate the pedestal so its thumbscrews and handle face upwards while the azimuth connector faces downwards.

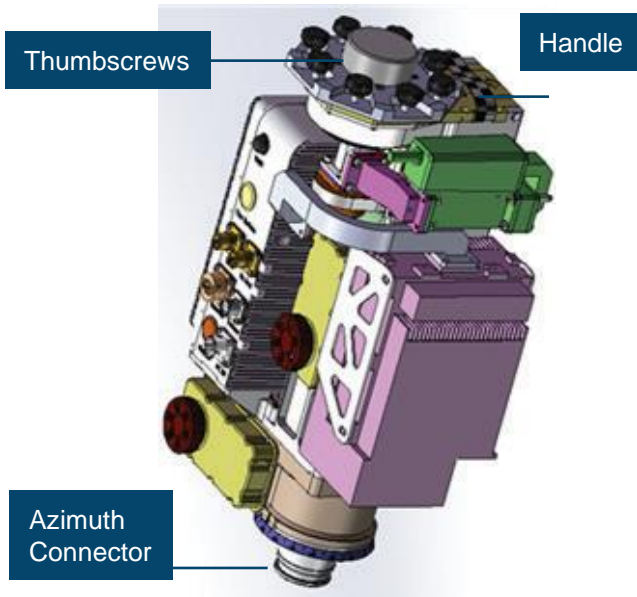

8. Carry the pedestal by the handle at the top of the pedestal.
9. Insert the azimuth connector into the tripod center.
10. Ensure the pedestal sits flat onto the tripod.
11. Adjust the orientation so that front points to the satellite belt.

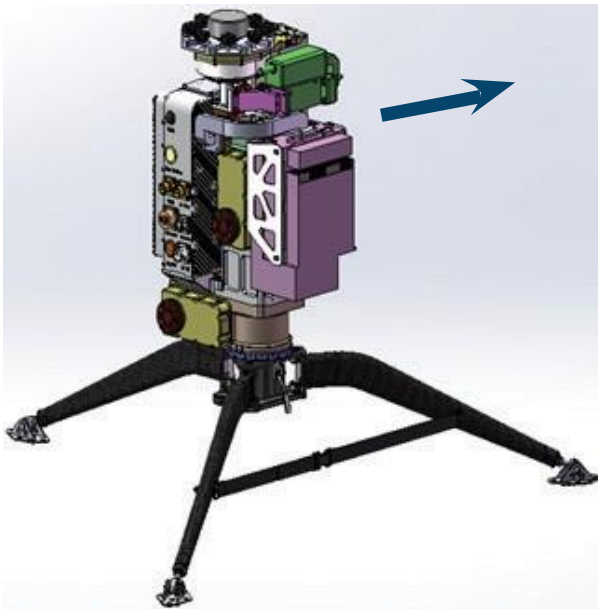

12. Push down the latch on the tripod to lock the pedestal into place.
13. Take out the feed assembly.
14. Remove the feed cover by holding the feed collar and rotating the feed cover counterclockwise.

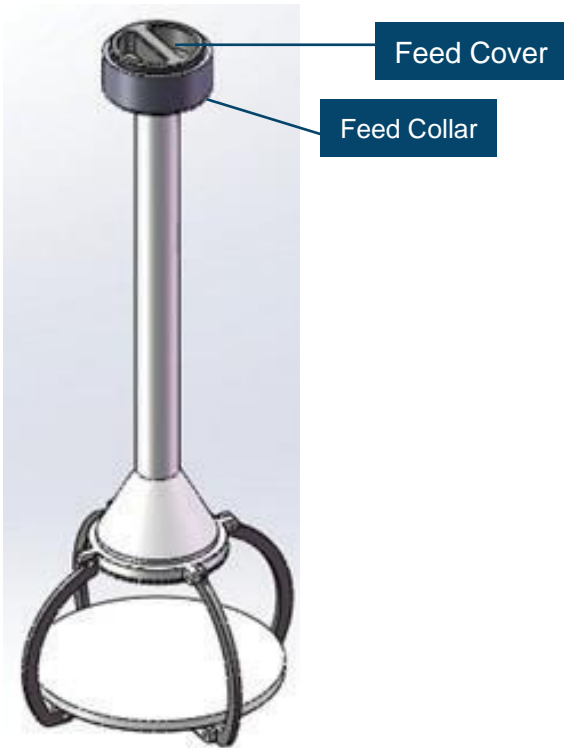

15. Remove feed mount cover from top of pedestal.

Note: Both exposed feed interfaces on the feed assembly and pedestal will have a matching slot and pin respectively.

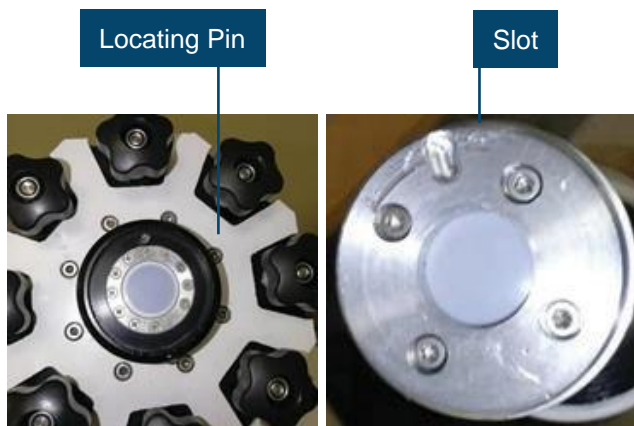

16. Align the locating pin from feed mount to the indented slot.
17. Assemble feed to feed mount by tightening the feed collar clockwise.

Note: At this stage, the terminal should look like as follows:



18. Unpack the reflector petals.

Note: Each petal is labeled with a number from 1 to 8 with a corresponding position on the pedestal.

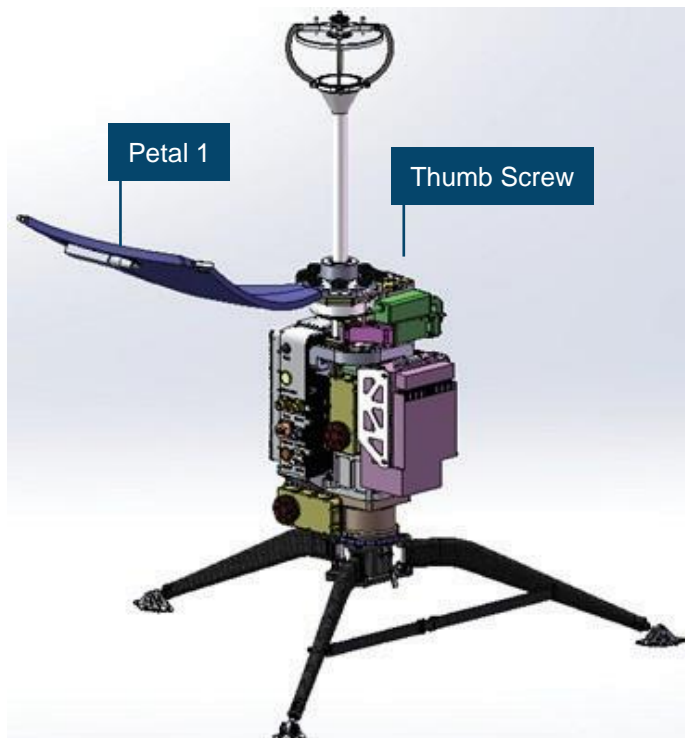

19. Repeat the following steps when installing petals 1 through 8 in ascending order:
- Loosen the thumbscrew to limit
 - Insert the reflector petal into the pedestal
 - Lock the reflector petal into place by tightening the thumbscrew.
 - Engage the latch between any adjacent petals by following the steps outlined in the sequence below:



Push in the center pin with metal handle parallel to top surface. The latch will be facing the ground.

Rotate latch 90 degrees perpendicular to top surface

Fold down latch to top surface and secure it so that petals are connected to each other.

20. Assembly is now complete.

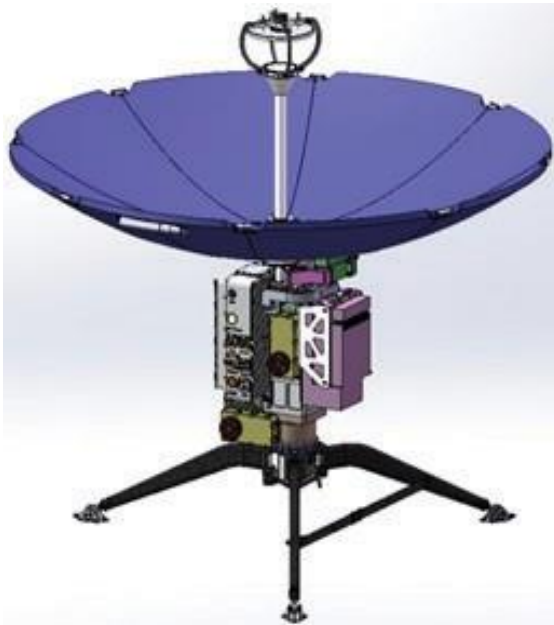

5.2 Cable Connection

Connect cables according to the table below. Ensure to connect the antenna and BUC power supplies to the AC outlet last.

Note: For OpenAMIP connection, the remote end of the remote cable from the ACU needs to output to both the computer and modem through a switch.

Refer to the next page for the connection diagram for both Open and Non-OpenAMIP modem implementations.

SIGNAL	ACU Port	TO	CABLE
DC Power Input	DC IN	Power Supply	Power Supply DC Cable
Compass Data	SENSOR	Compass on Petal	Sensor Cable
Tx Signal	Tx	Modem Tx Port	Tx Cable (Red End)
Rx Signal	Rx	Modem Rx Port	Rx Cable (Green End)
GPS Data	MODEM	Modem Console Port	Modem cable
Remote Control	REMOTE	Laptop (and Modem LAN port for OpenAMIP)	Remote cable
BUC DC Power Input (Optional)	BUC DC IN	BUC Power Supply	Power Supply DC Cable

Connection Diagram for Non-OpenAMIP Modem:

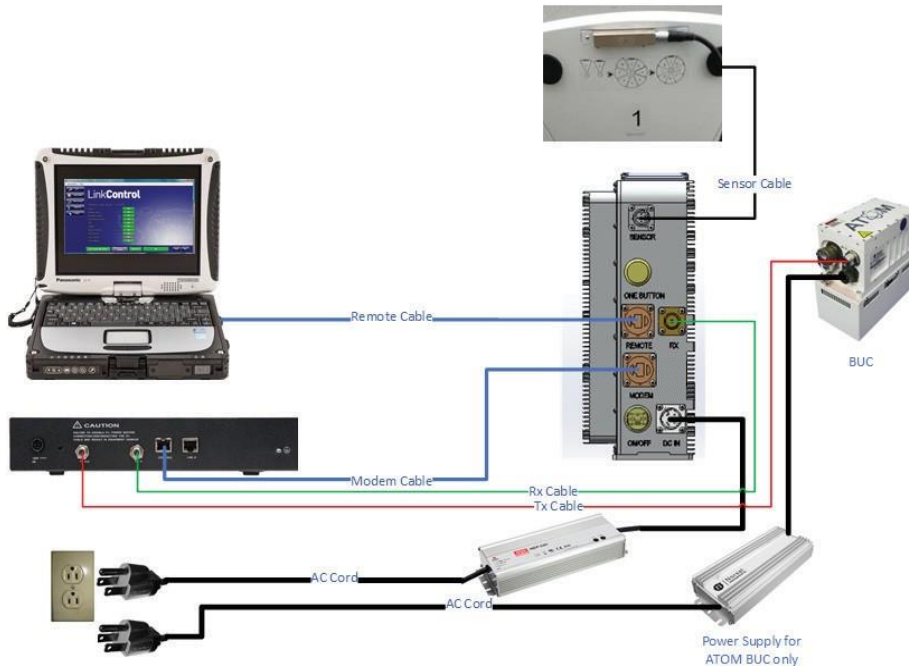

Connection Diagram for OpenAMIP Modem:

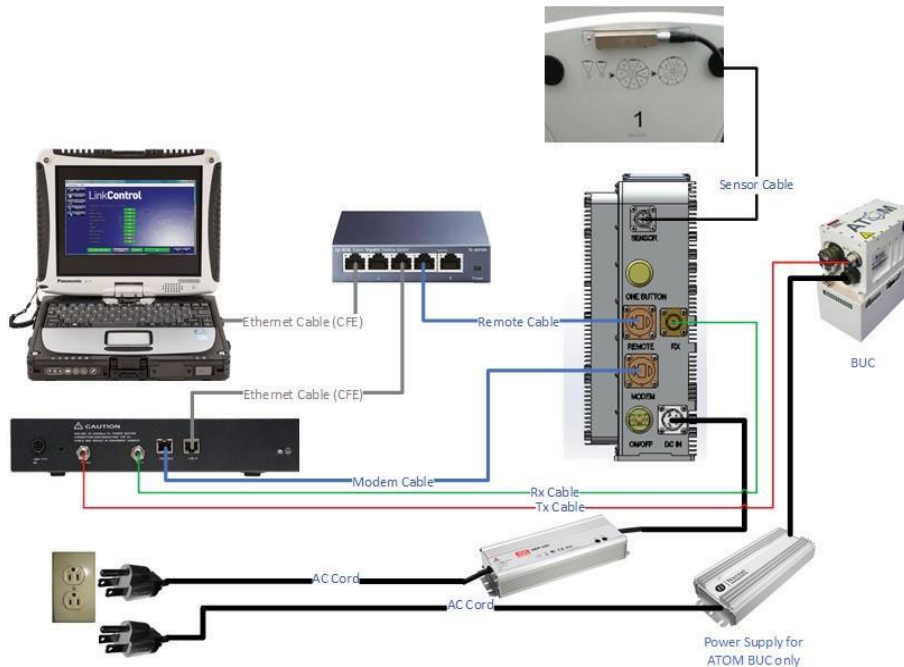

5.3 Auto-Acquire

Note: Refer to the LinkControl user manual for detail information in using LinkControl.

5.3.1 Using Non-OpenAMIP

1. Once the antenna is powered on and connected to the computer, open **LinkControl**
2. Wait for all indicators in the **Start** page to show up as either **OK** or **N/A**



3. Click **LinkProfiles** navigation button and ensure a Non-OpenAMIP LinkProfile profile has been applied.
4. Select and apply the LinkProfile if the LinkProfile is not already active.

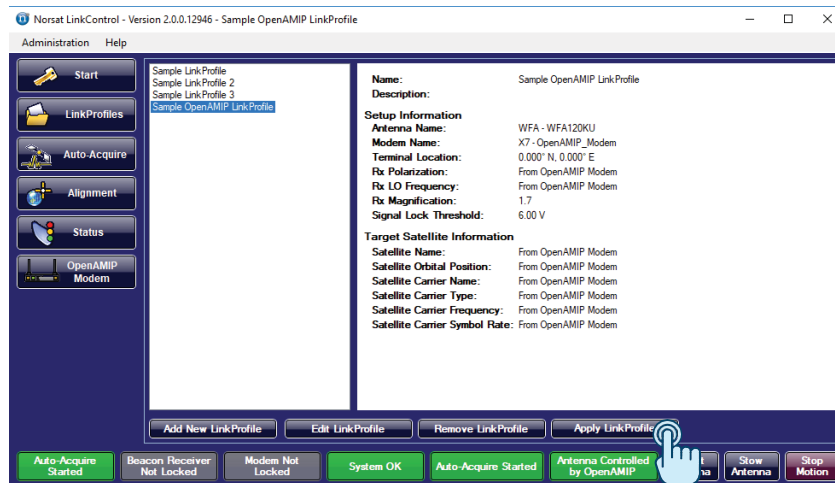

5. Click **Auto-Acquire** navigation button.

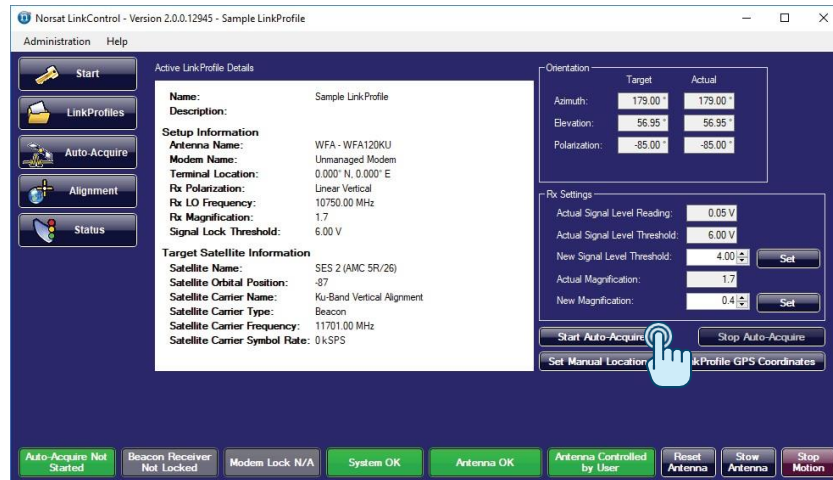

6. Click **Start Auto-Acquire** and antenna will start auto-acquisition with pre-set signal level threshold and signal magnification.
7. Monitor the **Actual Signal Level Reading** reported while the antenna is auto-acquiring.
 - a. If the signal level reading is saturated at 9.99V the user may lower the magnification to avoid unoptimized pointing.
 - b. If signal level reading is below the threshold during pointing, the user may lower the signal level threshold or raise the magnification to avoid failure in pointing.
8. Once Pointing is completed, system status will show as Auto-Acquire completed.

5.3.2 Using OpenAMIP

1. Once the antenna is powered on and connected to the computer, open **LinkControl**
2. Wait for all indicators in the **Start** page to show up as either **OK** or **N/A**
3. Click **LinkProfiles** navigation button and ensure an OpenAMIP LinkProfile profile has been applied.
4. Select and apply the LinkProfile if the LinkProfile is not already active.
5. Once the system is ready, the OpenAMIP modem will attempt to initiate an auto-acquire and a pop-up message will appear.
 - a. Select **Proceed** to allow the auto-acquire to initiate.
 - b. Select **Abort** to prevent the auto-acquire from initiating and to place the Antenna in User Controlled Mode (Refer to Section 5.3.1 to perform a Non-OpenAMIP auto-acquire)



6. Monitor the **Actual Signal Level Reading** reported while the antenna is auto-acquiring.
 - a. If the signal level reading is saturated at 9.99V the user may lower the magnification to avoid unoptimized pointing.
 - b. If signal level reading is below the threshold during pointing, the user may lower the signal level threshold or raise the magnification to avoid failure in pointing.

7. Once Pointing is completed, system status will show as Auto-Acquire completed.

Note: Refer to navigate to the Modem page for information on the current modem parameters.



6. System Maintenance

Regular maintenance is recommended per the schedule below:

NO.	DESCRIPTION	FREQUENCY
1	Inspect and clean integrity of feed horn window, replace when damaged	Once per month
2	Inspect OMT and waveguide sealing, if there is a leakage, dry out the components and seal with silicon fusion tape or replace damaged parts.	Once per month
3	Inspect screws and nuts, tighten, or replace screws upon loosening or rusting	Once per month
4	Inspect system for any noise during operation. Clean up the transmission and lubricate if any noise	Once per month
5	Inspect paint integrity of the antenna, touch up when required	Once per month
6	Inspect wear and tear of timing belt and lubricate gears and transmissions. Replace when required	Once per year
7	Calibrate compass to ensure correct heading	Once per year
8	Clean the petal surface	Every 3 months or required when exposed to extreme conditions

7. Factory Reset

To factory reset the terminal, perform the following steps:

1. Connect the antenna to power.
2. While pressing 'One Button', press 'On/Off' button to turn on system.
3. Do not release 'One Button' until system beeps twice.
4. The system is now reset to factory settings.

Note: All limit switch information and encoder calibration information will be restored.

8. Technical Specification

ELECTRICAL	
Reflector Aperture	1.2m
Reflector Material	Carbon Fibre
Feed Configuration	Center
Tx Frequency	13.75 to 14.50 GHz
Rx Frequency	10.70 to 12.75 GHz
Tx Gain	42.8+20lg(f/14.125) dBi
Rx Gain	41.5+20lg(f/11.85) dBi
Polarization	Linear
Cross Polarization (On-Axis)	≥ 35 dB
Tx/Rx Isolation (Port Isolation)	Tx ≥ 85 dB; Rx ≥ 40dB
Sidelobe	≤-14 dB (First Sidelobe)
Azimuth Range	± 200°
Elevation Range	10° to 90°
Polarization Range	± 90°
Azimuth Speed	0.1°/s to 3°/s
Elevation Speed	0.1°/s to 3°/s
Polarization Speed	0.1°/s to 1°/s
Feed Interface	WR75
Power Supply	AC110-230V, 50/60Hz, Rated 200W, 550W Max

MECHANICAL	
Case 1 – Size	79.5cm (L) x 51.8cm (W) x 31cm (H)
Case 1 – Weight	≤ 32kg
Case 2 – Size	84.5cm (L) x 62cm (W) x 49cm (H)
Case 2 – Weight	≤ 32kg

ENVIRONMENTAL	
Wind Load – Operational	36km/h
Wind Load – Survival	61km/h
Temperature	-30°C to +60°C
Humidity	0 to 95%
Water Ingress	IP65 (Antenna Only)

Appendix A – Magnetic Declination Map

US/UK World Magnetic Model - Epoch 2015.0
Main Field Declination (D)

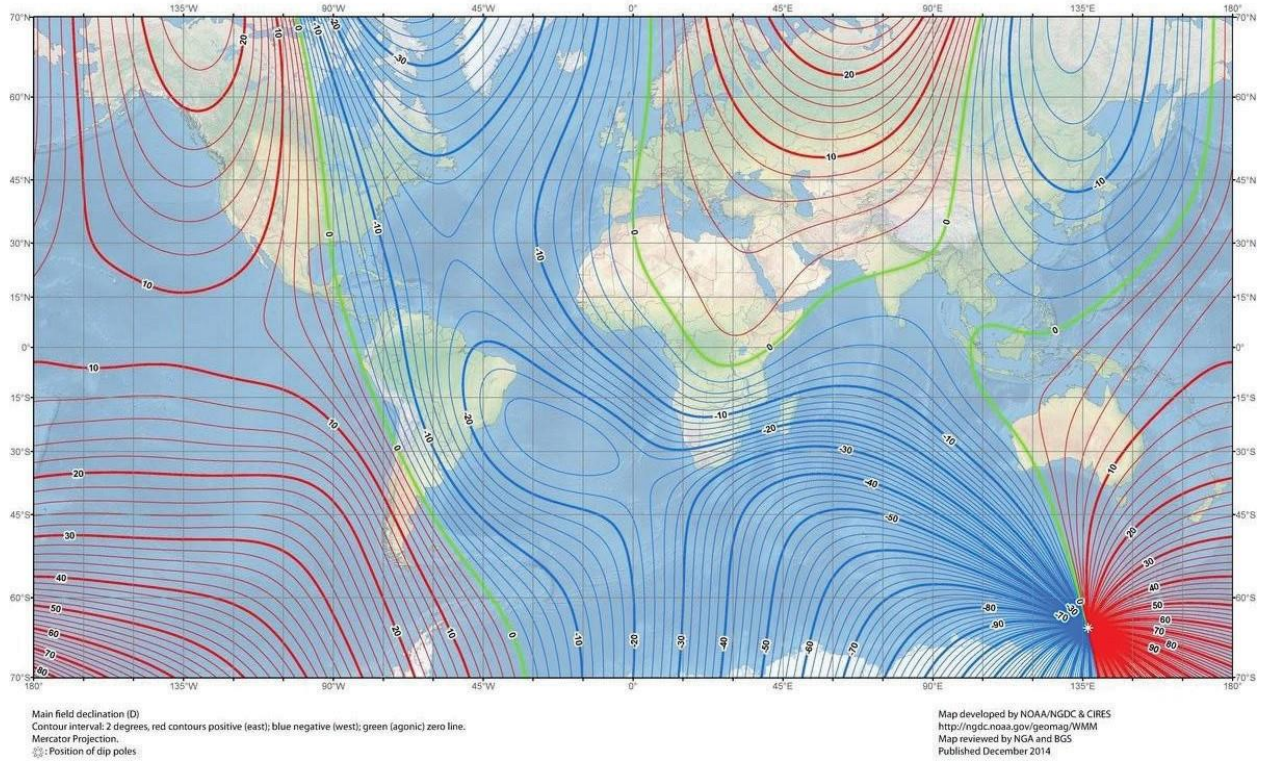

US/UK World Magnetic Model - Epoch 2015.0 Main Field
Declination. (2014, December).

Retrieved from <http://ngdc.noaa.gov/geomag/WMM>



Norsat
International Inc.

ABOUT NORSAT

Norsat International Inc., founded in 1977, is a leading provider of innovative communication solutions that enable the transmission of data, audio and video for remote and challenging applications. Norsat's products and services include customizable satellite components, portable satellite terminals, maritime solutions and satellite networks. The company's products and services are used extensively by telecommunications services providers, emergency services and homeland security agencies, military organizations, health care providers and Fortune 1000 companies.

110 – 4020 Viking Way | Richmond | British Columbia | Canada

V6V 2L4 | support@norsat.com

www.norsat.com