



C-BAND INTERFERENCE SOLUTION

5G INTERFERENCE PLL LNB

3200-BPF / 3200-sBPF



Norsat
International Inc.
3200-BPF-1
C-Band LNB
5G Rejection

Input: 3.7 - 4.2 GHz
LO Freq: 5.15 GHz
Stability: +/- 10 kHz
Gain: 62 dB(Typ)
Temp: 45K
DC Input: +12 to +24V

5G BAND PASS FILTER

BPF-C / eBPF-C



Norsat
International Inc.
BPF-C-1
C-BAND
BAND PASS FILTER
3.70-4.200 GHz
100-0001
63200

For more information, please visit www.norsat.com/5g-interference



Norsat
International Inc.

NEW TO THE FAMILY!

5G INTERFERENCE PLL LNB 3200-sBPF



- Combines an LNB plus a Band Pass Filter into the same compact form factor as a Norsat 3000 series LNB
- Ideal for mobile terminal applications
- Switch filtering between full and narrow portions of the C-Band spectrum
- Rejects terrestrial interference in C-Band (5G, radar and C-Band transmitters)

5G BAND PASS FILTER eBPF-C



- Rejects terrestrial interference in C-Band (5G, Radar and C-Band transmitter)
- Exceptional performance with narrow, < 20 MHz, guard band
- Easily installed between the feed and LNB
- Suitable for use with Norsat's C-Band LNBs
- Environmentally sealed and moisture resistant (IP66)

3200-BPF



C-BAND 5G Interference PLL LNB

- Rejects terrestrial interference in C-band (5G, Radar and C-Band transmitter)
- In the same housing as Norsat 3000 LNBs
- Mitigates interference signals less than -25 dBm with no degradation
- Can be used with Norsat's BPF-C for additional 5G rejection

BPF-C



C-BAND 5G BAND PASS FILTER

- Features a broad passband with low insertion loss, steep skirts that roll off quickly, and high stopband rejection.
- Easily installed between the feed and LNB
- Suitable for use with Norsat's C-Band LNBs
- Environmentally sealed and moisture resistant (IP66)

5G INTERFERENCE IMMUNITY– CHOOSING THE BEST SOLUTION

Introduction

5G networks in the 3.4 to 4.0 GHz band are coming and will cause interference problems in the satellite C-band receive spectrum 3.4 - 4.2 GHz. To maximize available spectrum the guard bands between the 5G systems and the satellite receive bands will get smaller and smaller. New filters and LNBS are required to ensure immunity to these 5G systems.

Impact of 5G Interference on LNBS

A massive MIMO 5G base station could easily generate 75 dBm EIRP with their high-power amplifiers and directional antennas. Distance and the relative angles between the 5G antenna and the satellite antenna provide some immunity, but interfering signals of -15 dBm or higher at the input to the LNB are possible. In built up areas, there may be several 5G base stations causing interference. Contrast this to satellite receive signals that are typically -90 dBm to -120 dBm. An LNB typically has about 60 dB gain and an output 1 dB compression point of between 5 and 10 dBm. It is good practice to ensure that the aggregate output power is kept well below this so aggregate power at the input of the LNB should be less than -55 dBm. Interfering signals of -55 dBm will start to cause the LNB to saturate and cause interference problems.

High power signals from 5G base stations, even out of band signals at the input of the LNB will cause:

- 1) reduced gain;
- 2) Increase in noise temperature
- 3) increased noise; and
- 4) non-linear intermodulation products.

This interference occurs because the high-power signal saturates the first amplifier stages or saturates the mixer. By far the worst degradation occurs due to intermodulation resulting in reduce picture quality or degraded BER performance in data networks. Intermodulation is the generation of mixing products between the interference signals, the LNB LO and any in-band signals. The following figure of a standard LNB output shows the in-band intermodulation products for a -34 dBm interfering signal at 3.6 GHz (Marker 2) with a desired signal at 3.95 GHz (Marker 1).

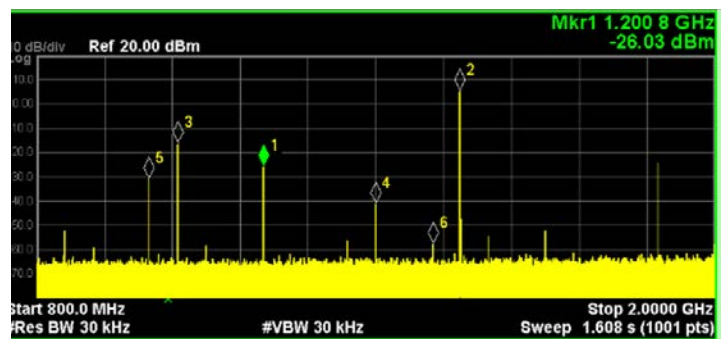

In addition to the in-band spurs, the interfering signal is saturating the LNB and appears at the IF output as a very strong signal. A typical modem requires the aggregate L-band input power to the to be no more than about -5 dBm. The interfering signal leaking through the LNB must be kept below this to ensure the modem performance is not impacted.

Many of the spurs are in-band so L-Band or IF filters placed between the LNB and modem will not be effective. Equally, LNBs with integrated L-band filters will not provide immunity. Appropriate L-band filters could mitigate the IF interfering signal. To provide immunity to 5G interference requires:

- a) LNB with integrated filtering and designed to handle higher power
- b) Passband waveguide filter in front of the LNB
- c) Combination of an external filter and LNB with integrated filter

LNB with Integrated filtering

The Norsat 3200-BPF series LNBs are designed to mitigate 5G interference. They include band-pass filters after the first amplifier stage, a mixer that can withstand higher power and IF filtering. The Norsat 3200 filter can successfully mitigate the intermodulation affects with interference up to about -25 dBm. The figure on the left shows the LNB output with no interference. The figure on the right shows the Norsat 3200-BPF LNB output with an interfering signal at -22 dBm. The output spectrum is unaffected by the interfering signal; however, the interfering signal is still present at the L-band output of the LNB and is high enough in power to cause degradation in modem performance.

The 3200-BPF LNB with integrated filter is much different than the typical WiMAX or radar tolerant LNBs. These LNBs usually only have filtering at IF. They cannot mitigate in-band interference which will cause intermodulation products in the RF and mixer stages of the LNB. The 3200-BPF includes filtering at RF to mitigate this.

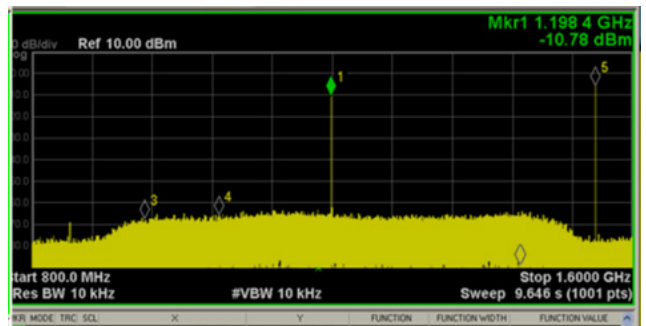
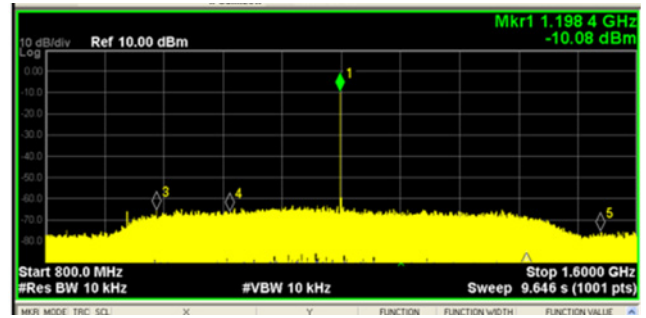

Passband Waveguide filter in front of the LNB

Passband waveguide filter designed to eliminate 5G signals placed in front of the LNB can be used in place of a transmit reject filter can mitigate 5G interference. External filters work by reducing the power of the 5G interference while passing the desired signals. All filters have a transition region between the stop band and the pass band. The rejection in this transition region is much less than in the stop band. The effectiveness of the filter on mitigating the 5G interference depends on how close to the pass band the 5G interference is. The Norsat BPF-C BPF filters provides about 58 dB, 28 dB and 3 dB rejection at 100 MHz, 50 MHz and 20 MHz from the pass band respectively. It is quite possible that this filter will not provide immunity to 5G interference if the interferer is close to the pass band and is high power.

Norsat also offers a set of extreme band pass filters that provide more rejection closer to the passband. For example, the eBPF provides 70 dB, 65 dB and 60 dB rejection at 100 MHz, 50 MHz and 20 MHz offsets respectively. However, the insertion loss of these filters is about 0.8 dB more than standard filter and this will impact the system G/T and the received Eb/No.

Combination of an external filter and LNB with integrated filter

In cases where the 5G signal is high and the guard band between the 5G network and the satellite receive spectrum is less than 100 MHz, a combination of an external filter and LNB with integrated filter is required. The following graph shows measured rejection of the Norsat

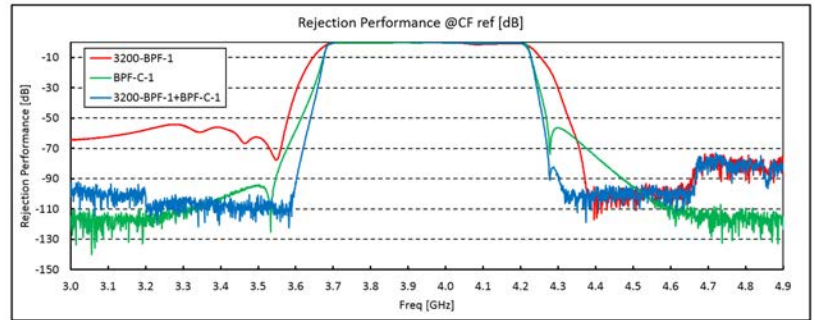

3200-BPF-1 LNB (LNB with integrated 5G filter), the BPF-C-1 (5G waveguide BPF) and the combination of the BPF and the LNB with integrated filter. In all cases the passband is 3.7-4.2 GHz.

The combination of the Norsat 3200-BPF LNB and a Norsat BPF-C will resolve most interference problems where the 5G signal is at least 100 MHz from the pass band. In cases where guard bands are less it is necessary to use the Norsat eBPF-C filters.

5G Immunity Solutions

The following tables summarize the immunity to 5G signals for various combinations of LNB and filter for guard bands of 100 MHz, 50 MHz and 20 MHz below the band edge and are sorted from lowest to highest immunity. The values in the table indicate the highest level of interference that the LNB/Filter combination can handle without impacting the LNB performance. The tables below assume a received signal of about -70 dBm. The immunity on the upper band edge is less, but this is not critical for interference mitigation.

Solution	Signal Level @ 100 MHz Causing Interference (dBm)
3000 LNB (Standard LNB)	-65
3200-BPF	-30
BPF-C + 3000 LNB	-10
eBPF-C + 3000 LNB	0
BPF-C + 3200-BPF	25
eBPF-C + 3200 BPF	40

Solution	Signal Level @ 50 MHz Causing Interference (dBm)
eBPF-C + 3000 LNB	0
eBPF-C + 3200 BPF	10

Solution	Signal Level @ 20 MHz Causing Interference (dBm)
3000 LNB (Standard LNB)	-65
BPF-C + 3000 LNB	-65
3200-BPF	-60
BPF-C + 3200-BPF	-60
eBPF-C + 3000 LNB	-5
eBPF-C + 3200 BPF	0

The various combinations of LNB and filters have different insertion losses and noise figures and as such will affect system performance differently. The following table provides some guidance on the impact on system G/T of the various combinations:

Solution	Filter Insertion Loss (dB)	LNB Noise Figure (dB)	G/T dB/K (2.4m Antenna)	Change in G/T (dB)
3000 LNB	0	< 0.4	19.1	0
BPF-C + 3000 LNB	0.5	< 0.4	18.0	-0.9
eBPF-C + 3000 LNB	1.5	< 0.4	15.5	-3.6
3200-BPF	0	< 0.6	18.4	-0.7
BPF-C + 3200 BPF	0.5	< 0.6	17.4	-1.7
eBPF-C + 3200 BPF	1.5	< 0.6	15.1	-4.0

The table shows the more extreme solutions have more negative impact on system performance. Thus, it is important to balance the immunity solution with system performance.

Conclusion

To ensure the satellite receive spectrum is immune to 5G interference requires a combination of external waveguide filters and specially designed LNBS. Filters alone do not provide enough immunity especially for interferers close to the satellite band. LNBS designed with integrated RF filters, high power mixers and IF filters also do not provide enough immunity alone. The combinations available using the Norsat BPF-C, eBPF-C and 3200-BPF LNB allow tailored solutions that provide 5G immunity to the satellite spectrum while maximizing system performance.



MICROWAVE COMPONENT

C-BAND BAND PASS FILTER

APPLICATIONS

- Rejects terrestrial interference in C-Band (5G, Radar and C-Band transmitter)
- Easily installed between the feed and LNB
- Suitable for use with Norsat's C-Band LNBs
- Environmentally sealed and moisture resistant (IP66)

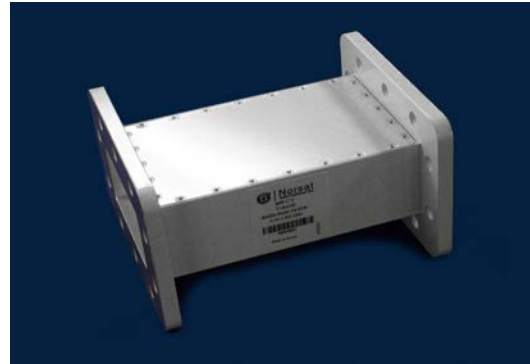

SPECIFICATIONS (BPF-C-1)

Frequency Range	3.70 to 4.20 GHz
VSWR	1.4 : 1 max.
Insertion Loss in Band	0.5 dB max.
Rejection	25 dB min at 3.650 GHz and 4.250 GHz 60 dB min at 3.550 GHz and 4.350 GHz 70 dB min at 3.500 GHz and 4.400 GHz
Group delay variation within +/-0.5MHz	0.6 nsec
Waveguide Flange	CPR-229G (input), CPR-229F (output)
Dimensions (L x W x H)	120 mm x 100 mm x 70 mm
Weight	< 650 g

SPECIFICATIONS (BPF-C-2)

Frequency Range	3.625 to 4.20 GHz
VSWR	1.4 : 1 max.
Insertion Loss in Band	0.5 dB max.
Rejection	25 dB min at 3.575 GHz and 4.250 GHz 60 dB min at 3.475 GHz and 4.350 GHz 70 dB min at 3.425 GHz and 4.400 GHz
Group delay variation within +/-0.5MHz	0.6 nsec
Waveguide Flange	CPR-229G (input), CPR-229F (output)
Dimensions (L x W x H)	120 mm x 100 mm x 70 mm
Weight	< 650 g

SPECIFICATIONS (BPF-C-3)

Frequency Range	3.754 to 4.20 GHz
VSWR	1.4 : 1 max.
Insertion Loss in Band	0.5 dB max.
Rejection	25 dB min at 3.704 GHz and 4.250 GHz 60 dB min at 3.604 GHz and 4.350 GHz 70 dB min at 3.554 GHz and 4.400 GHz
Group delay variation within +/-0.5MHz	0.6 nsec
Waveguide Flange	CPR-229G (input), CPR-229F (output)
Dimensions (L x W x H)	120 mm x 100 mm x 70 mm
Weight	< 650 g

SPECIFICATIONS (BPF-C-4)

Frequency Range	3.80 to 4.20 GHz
VSWR	1.4 : 1 max.
Insertion Loss in Band	0.5 dB max.
Rejection	25 dB in at 3.750 GHz and 4.250 GHz 60 dB min at 3.650 GHz and 4.350 GHz 70 dB min at 3.600 GHz and 4.400 GHz
Group delay variation within +/-0.5MHz	0.6 nsec
Waveguide Flange	CPR-229G (input), CPR-229F (output)
Dimensions (L x W x H)	120 mm x 100 mm x 70 mm
Weight	< 650 g





SPECIFICATIONS (BPF-C-5)

Frequency Range	3.90 to 4.20 GHz
VSWR	1.4 : 1 max.
Insertion Loss in Band	0.5 dB max.
Rejection	25 dB min at 3.850 GHz and 4.250 GHz 60 dB min at 3.750 GHz and 4.350 GHz 70 dB min at 3.700 GHz and 4.400 GHz
Group delay variation within +/-0.5MHz	0.6 nsec
Waveguide Flange	CPR-229G (input), CPR-229F (output)
Dimensions (L x W x H)	120 mm x 100 mm x 70 mm
Weight	< 650 g

SPECIFICATIONS (BPF-C-6)

Frequency Range	4.00 to 4.20 GHz
VSWR	1.4 : 1 max.
Insertion Loss in Band	0.5 dB max.
Rejection	25 dB min at 3.950 GHz and 4.250 GHz 60 dB min at 3.850 GHz and 4.350 GHz 70 dB min at 3.800 GHz and 4.400 GHz
Group delay variation within +/-0.5MHz	0.6 nsec
Waveguide Flange	CPR-229G (input), CPR-229F (output)
Dimensions (L x W x H)	120 mm x 100 mm x 70 mm
Weight	< 650 g

SPECIFICATIONS (BPF-C-7)

Frequency Range	4.10 to 4.20 GHz
VSWR	1.4 : 1 max.
Insertion Loss in Band	0.5 dB max.
Rejection	25 dB min at 4.05 GHz and 4.215 GHz 60 dB min at 3.950 GHz and 4.350 GHz 70 dB min at 3.900 GHz and 4.400 GHz
Group delay variation within +/-0.5MHz	0.6 nsec
Waveguide Flange	CPR-229G (input), CPR-229F (output)
Dimensions (L x W x H)	120 mm x 100 mm x 70 mm
Weight	< 650 g

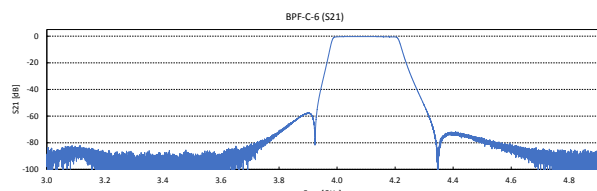
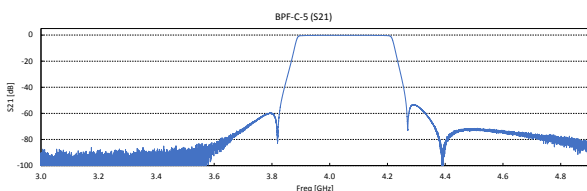
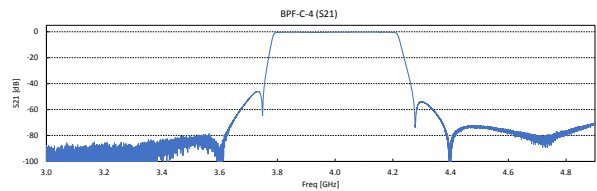
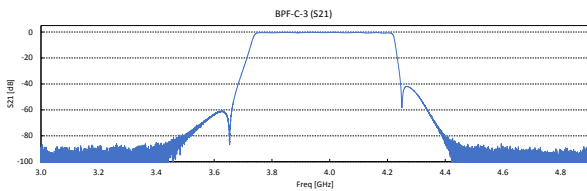
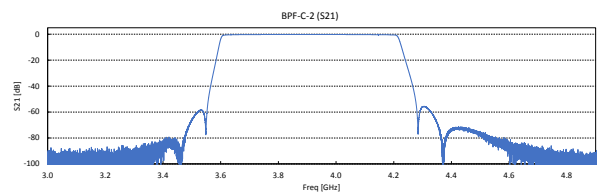
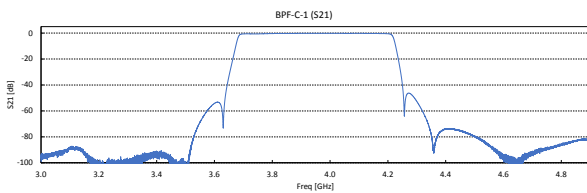



HOW TO ORDER

BPF-C-1

- FREQUENCY**
- 1: 3.70 - 4.20 GHz
 - 2: 3.60 - 4.20 GHz
 - 3: 3.75 - 4.20 GHz
 - 4: 3.80 - 4.20 GHz
 - 5: 3.90 - 4.20 GHz
 - 6: 4.00 - 4.20 GHz
 - 7: 4.10 - 4.20 GHz

MECHANICAL DIAGRAM

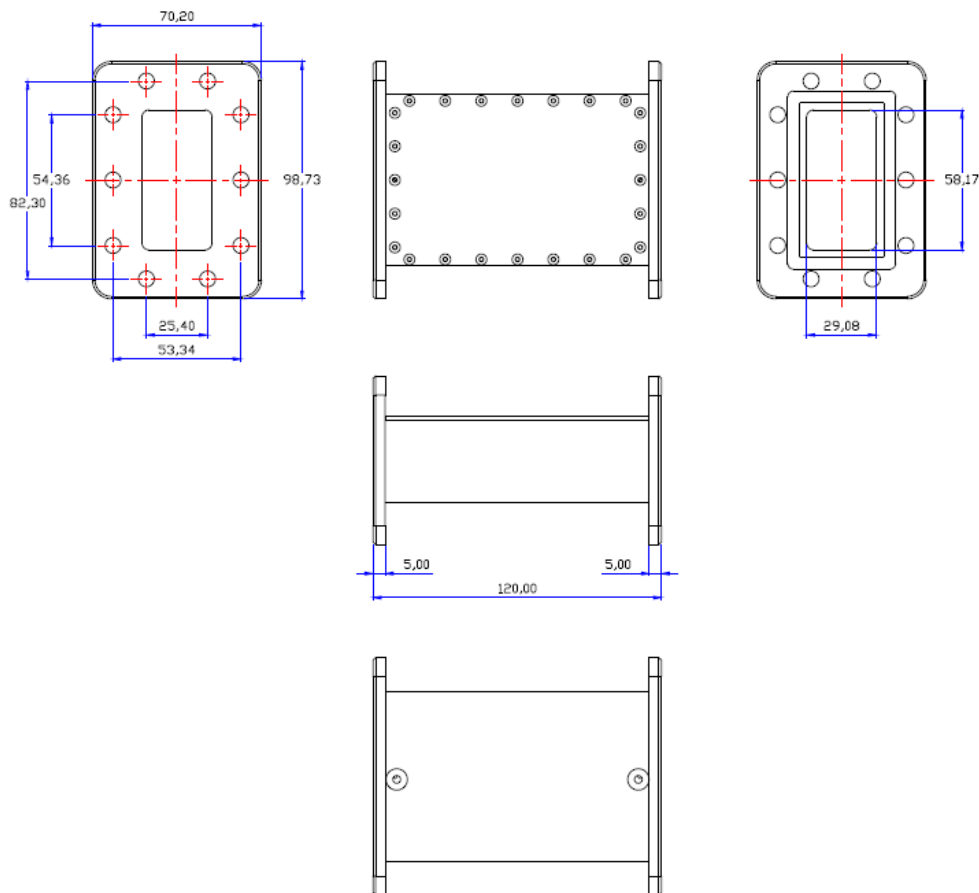



MICROWAVE COMPONENT

C-BAND eBPF-C EXTREME BAND PASS FILTER



APPLICATIONS

- Rejects terrestrial interference in C-Band (5G, Radar and C-Band transmitter)
- Exceptional performance with narrow, < 20 MHz, guard band
- Easily installed between the feed and LNB
- Suitable for use with Norsat's C-Band LNBs
- Environmentally sealed and moisture resistant (IP66)

SPECIFICATIONS (eBPF-C-1)

Frequency Range	3.70 - 4.20 GHz
VSWR	1.4 : 1 max.
Group Delay Variation within ± 0.5 MHz	3.0 ns max.
Insertion Loss in Band	1.4 dB max.
Rejection	60 dB min at 3.682 GHz 25 dB min at 4.230 GHz
Waveguide Flange	CPR-229G (input), CPR-229F (output)
Dimensions (L x W x H)	185 mm x 100 mm x 71 mm (7.28 in x 3.94 in x 2.79 in)
Weight	< 970 g

SPECIFICATIONS (eBPF-C-2)

Frequency Range	3.625 - 4.200 GHz
VSWR	1.4 : 1 max.
Group Delay Variation within ± 0.5 MHz	3.0 ns max.
Insertion Loss in Band	1.4 dB max.
Rejection	60 dB min at 3.607 GHz 25 dB min at 4.230 GHz
Waveguide Flange	CPR-229G (input), CPR-229F (output)
Dimensions (L x W x H)	185 mm x 100 mm x 71 mm (7.28 in x 3.94 in x 2.79 in)
Weight	< 970 g

SPECIFICATIONS (eBPF-C-3)

Frequency Range	3.754 - 4.200 GHz
VSWR	1.4 : 1 max.
Group Delay Variation within ± 0.5 MHz	3.0 ns max.
Insertion Loss in Band	1.4 dB max.
Rejection	60 dB min at 3.736 GHz 25 dB min at 4.230 GHz
Waveguide Flange	CPR-229G (input), CPR-229F (output)
Dimensions (L x W x H)	185 mm x 100 mm x 71 mm (7.28 in x 3.94 in x 2.79 in)
Weight	< 970 g

SPECIFICATIONS (eBPF-C-4)

Frequency Range	3.80 - 4.20 GHz
VSWR	1.4 : 1 max.
Group Delay Variation within ± 0.5 MHz	3.0 ns max.
Insertion Loss in Band	1.4 dB max.
Rejection	60 dB min at 3.782 GHz 25 dB min at 4.230 GHz
Waveguide Flange	CPR-229G (input), CPR-229F (output)
Dimensions (L x W x H)	185 mm x 100 mm x 71 mm (7.28 in x 3.94 in x 2.79 in)
Weight	< 970 g

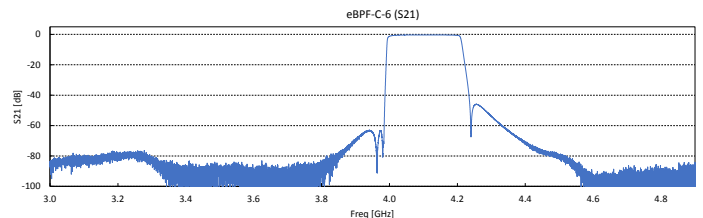
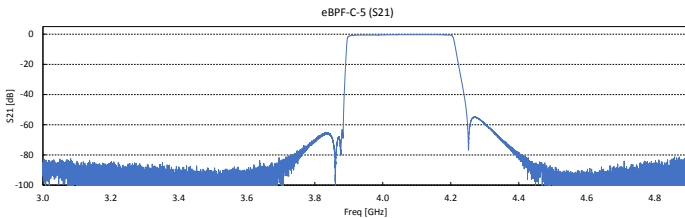

SPECIFICATIONS (eBPF-C-5)

Frequency Range	3.90 - 4.20 GHz
VSWR	1.4 : 1 max.
Group Delay Variation within ± 0.5 MHz	3.0 ns max.
Insertion Loss in Band	1.4 dB max.
Rejection	60 dB min at 3.882 GHz 25 dB min at 4.230 GHz
Waveguide Flange	CPR-229G (input), CPR-229F (output)
Dimensions (L x W x H)	185 mm x 100 mm x 71 mm (7.28 in x 3.94 in x 2.79 in)
Weight	< 970 g

SPECIFICATIONS (eBPF-C-6)

Frequency Range	4.00 - 4.20 GHz
VSWR	1.4 : 1 max.
Group Delay Variation within ± 0.5 MHz	3.0 ns max.
Insertion Loss in Band	1.4 dB max.
Rejection	60 dB min at 3.982 GHz 25 dB min at 4.230 GHz
Waveguide Flange	CPR-229G (input), CPR-229F (output)
Dimensions (L x W x H)	170 mm x 100 mm x 71 mm (6.69 in x 3.94 in x 2.79 in)
Weight	< 900 g

SPECIFICATIONS (eBPF-C-7)

Frequency Range	4.10 - 4.20 GHz
VSWR	1.4 : 1 max.
Group Delay Variation within ± 0.5 MHz	3.0 ns max.
Insertion Loss in Band	1.4 dB max.
Rejection	60 dB min at 4.082 GHz 25 dB min at 4.230 GHz
Waveguide Flange	CPR-229G (input), CPR-229F (output)
Dimensions (L x W x H)	160 mm x 100 mm x 71 mm (6.3 in x 3.94 in x 2.79 in)
Weight	< 900 g

HOW TO ORDER

eBPF-C-5

- FREQUENCY**
- 1: 3.700 - 4.200 GHz
 - 2: 3.625 - 4.200 GHz
 - 3: 3.754 - 4.200 GHz
 - 4: 3.800 - 4.200 GHz
 - 5: 3.900 - 4.200 GHz
 - 6: 4.000 - 4.200 GHz
 - 7: 4.100 - 4.200 GHz



MECHANICAL DIAGRAM

eBPF-C-5

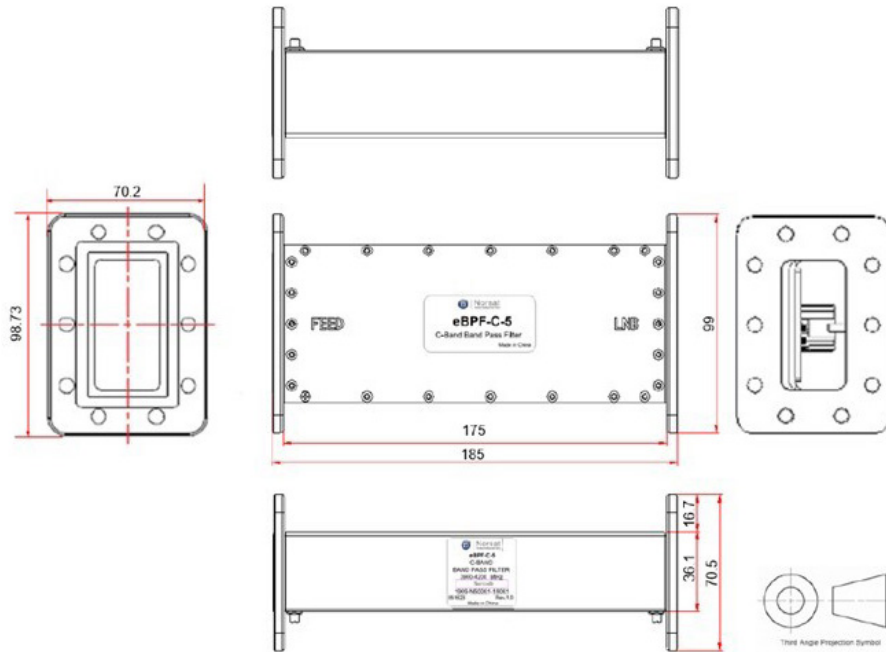

eBPF-C-6

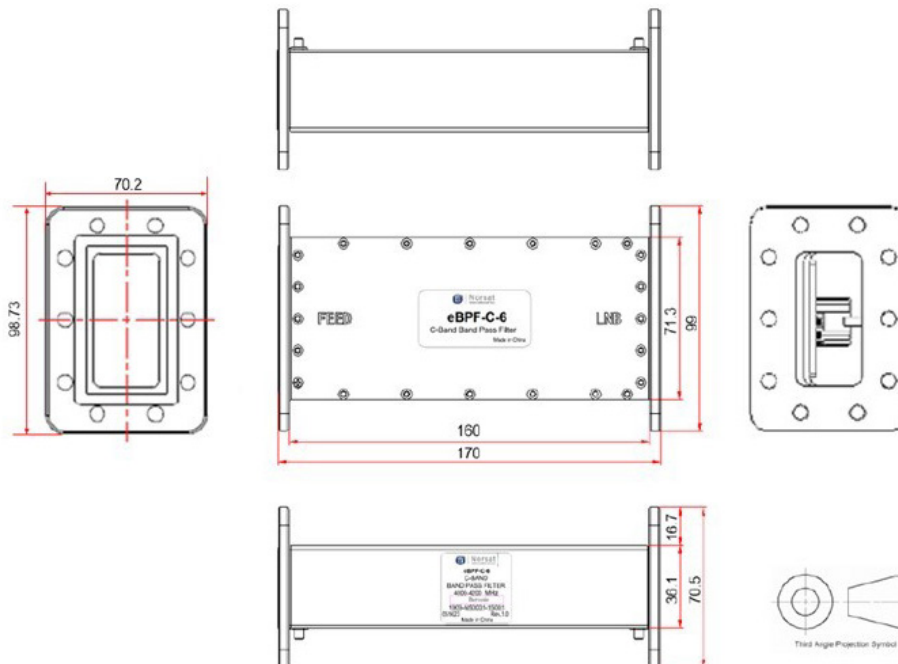



LNB

C-BAND PLL

3200-BPF

5G INTERFERENCE LNB

SPECIFICATIONS



Noise Temperature	60K max. at room temp. @ CF
Phase Noise (SSB) max.	-80 dBc/Hz at 1kHz -85 dBc/Hz at 10kHz -95 dBc/Hz at 100kHz
Input VSWR	2.2 : 1 max.
Output VSWR	2.5 : 1 max.
Gain	60 dB typ., 55 dB min., 70 dB max.
Gain Flatness (over full band)	≤ 6 dB p-p
Output P1dB	+ 9 dBm min.
Interference Rejection Signal	-25 dBm max. with no degradation

DC Power	+ 12V to + 24V DC
Current	400 mA max.
Input (waterproof)	CPR229G waveguide grooved
Output (waterproof)	F-Connector (75 Ohm) N-Connector (50 Ohm)
Dimensions (L x W x H) (F connector)	159 mm x 98.5 mm x 70mm (6.26 in x 3.88 in x 2.75 in)
Weight	500 g (17.64 oz)
Operating Temperature	- 40 to + 60°C
Storage Temperature	- 40 to + 80°C

FREQUENCY BANDS

	Option 1	Option 2	Option 3	Option 4	Option 5	Option 6	Option 7	Option 8
Frequency Band (GHz)	3.70 - 4.20	3.625 - 4.20	3.754 - 4.20	3.80 - 4.20	3.90 - 4.20	4.00 - 4.20	4.10 - 4.20	3.82 - 4.20
L.O. Frequency (GHz)	5.15	5.15	5.15	5.15	5.15	5.15	5.15	5.15
IF Frequency (MHz)	950 - 1450	950 - 1525	950 - 1396	950 - 1350	950 - 1250	950 - 1150	950 - 1050	950 - 1330
Rejection Range	< 3.6 GHz and > 4.8 GHz	< 3.525 GHz and > 4.8 GHz	< 3.654 GHz and > 4.8 GHz	< 3.7 GHz and > 4.8 GHz	< 3.8 GHz and > 4.8 GHz	< 3.9 GHz and > 4.8 GHz	< 4.0 GHz and > 4.8 GHz	< 3.72 GHz and > 4.8 GHz

HOW TO ORDER

3200N-BPF-1

FREQUENCY (OPTION)	1: 3.70 - 4.20 GHz 2: 3.625 - 4.20 GHz 3: 3.754 - 4.20 GHz 4: 3.80 - 4.20 GHz 5: 3.90 - 4.20 GHz 6: 4.00 - 4.20 GHz 7: 4.10 - 4.20 GHz 8: 3.82 - 4.20 GHz
CONNECTOR	F - 75 Ohm N - 50 Ohm
L.O. STABILITY	1: ±10KHz 2: ±25KHz
LNB SERIES #	

MECHANICAL DIAGRAM

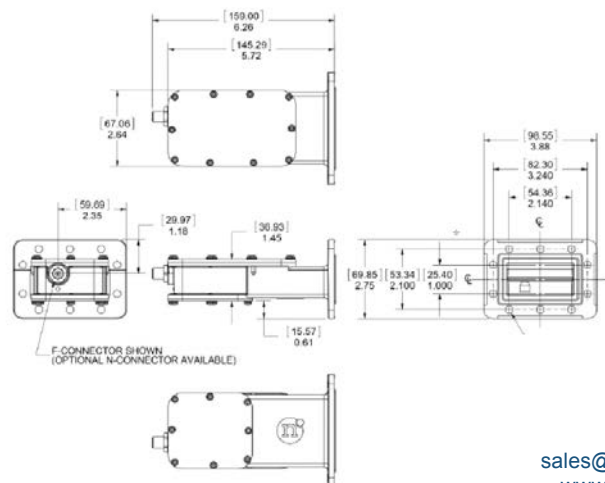



LNB

C-BAND PLL

3200-sBPF

5G INTERFERENCE LNB

SPECIFICATIONS



Noise Temperature	60K max. at room temp. @ CF
Phase Noise (SSB) max.	-80 dBc/Hz at 1kHz -85 dBc/Hz at 10kHz -95 dBc/Hz at 100kHz
Input VSWR	2.2 : 1 max.
Output VSWR	2.5 : 1 max.
Gain	62 dB typ., 55 dB min., 70 dB max.
Gain Flatness (over full band)	≤ 6 dB p-p
Output P1dB	+9 dBm min.

DC Power	+12V to +24V DC
Current	400 mA max.
Switching Voltage	Band 1: 13V Band 2: 18V
Input (waterproof)	WR-229 waveguide grooved
Output (waterproof)	Type F Connector (75 Ohm) Type N Connector (50 Ohm)
Dimensions (L x W x H)	159 mm x 98.55 mm x 69.85 mm (6.26 in x 3.88 in x 2.75 in)
Weight	500 g (17.64 oz)
Operating Temperature	-40 to +60°C
Storage Temperature	-50 to +70°C
Protection Rating	IP66

FREQUENCY BANDS

	3200-sBPF-5	3200-sBPF-6
	Band 1	Band 2
Input Frequency (GHz)	3.40 - 4.20	3.90 - 4.20
L.O. Frequency (GHz)	5.15	5.15
Output Frequency (MHz)	950 - 1750	950 - 1150
Rejection (-25dBm interference signal)	No rejection	< 3.8 GHz and > 4.8 GHz with no degradation

HOW TO ORDER

3200N-sBPF-5

FREQUENCY	5: 3.40 - 4.20 / 3.90 - 4.20 GHz 6: 3.40 - 4.20 / 4.00 - 4.20 GHz
SWITCHABLE	
CONNECTOR	F: Type F Connector (75 Ohm) N: Type N Connector (50 Ohm)
L.O. STABILITY	1: ± 10 kHz 2: ± 25 kHz
LNB SERIES #	

MECHANICAL DIAGRAM

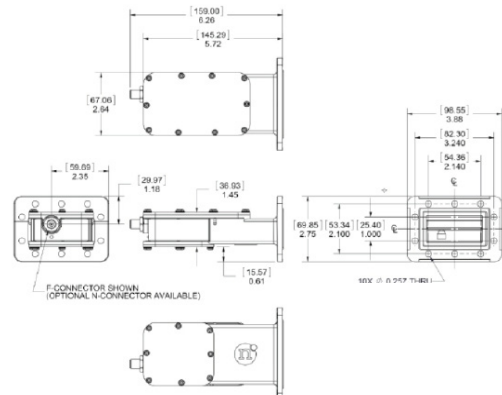

ABOUT NORSAT

Norsat International Inc., founded in 1977, is a leading provider of innovative communication solutions that enable the transmission of data, audio and video for remote and challenging applications. Norsat's products and services include customizable satellite components, portable satellite terminals, maritime solutions and satellite networks. The company's products and services are used extensively by telecommunications services providers, emergency services and homeland security agencies, military organizations, health care providers and Fortune 1000 companies.

CONTACT US

Norsat International Inc.
110 - 4020 Viking Way
Richmond, BC
V6V 2L4 Canada

sales@norsat.com
www.norsat.com

