

SPLIT-CORE CURRENT TRANSFORMER

JM21F-XXX-333mV series

UL US E344623 CE RoHS



JM21F series of split-core current transformer offers 100mA at secondary from sensed primary current. Without using secondary CT inside of meter, users directly connect JM21X series to a meter for high accuracy metering application. It enables one meter to be adopted for various current rating by only changing primary CT so it makes compact design meter and reduces developing cost. Also, over-voltage protection circuit is included to offer safe, fast and cost effective installation.

APPLICATIONS

- Power meter
- Switchgear
- Distributed measurement systems
- General Sets
- Control panels

BENEFITS

- Small-size, light-weight
- Simple Installation
- Over-Voltage protection circuit is installed.



FEATURES

- PC spring, output-terminal, secure locking hinge, one-touch structure make easy to install to the existent equipments such as a power distribution boards.
- Isolated plastic case recognized according to UL94-V0
- UL / EN 61010 - 1 certified

NOTICE

- Core contact surface is waterproofed, however if it gets rusty, you could reuse after removing rusts with spraying WD-40 or CRC5-56 on the rusted side.
- Do not use any other chemicals except WD-40 or CRC5-56 on housing or any other parts.
- Customizing output lead wire

HOW TO USE 1

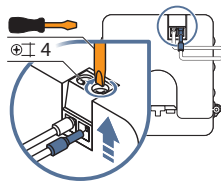

2

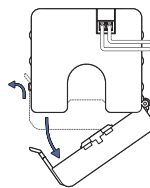

3

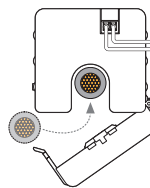

4

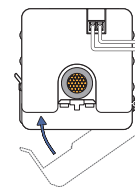

5

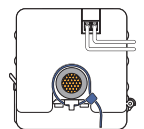

SPECIFICATION

(F=50/60Hz)

Accuracy	Class 1.0
System Voltage	720V(0.72kV)
Overload withstand	1.2 times rated current continuously
Compliant with	IEC/EN61869-2 & IEC61010-1
Operating Temperature Range	-20°C to 55°C
Relative Humidity	0-85% non-condensing
Test Voltage	3kV for 1minute
Frequency Range	50/60Hz
Protection Level	3.0V0-P
Insulation Category	CAT II or CAT III 600VAC

CURRENT TRANSFORMER RATIOS

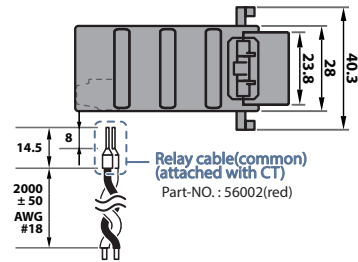
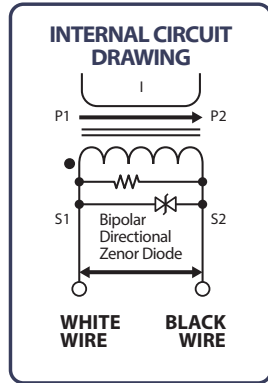
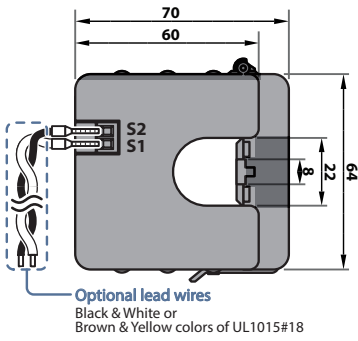

• PANEL MOUNT

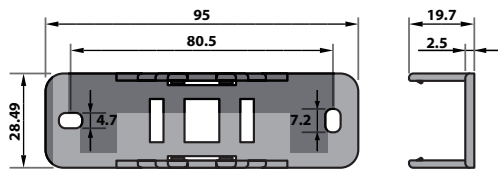

• DIN RAIL MOUNT

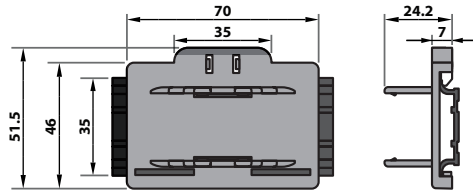

How to Order / Model Reference

eg **JM21F-000/333mV**

Model **J M 2 1 F**

Primary Current

Select code from ratio table

Secondary Voltage

333mV

3 3 3 mV

Current Transformer Ratios

Primary Current (A)	Metering Burden(VA)			Code
	cl. 0.5S	cl. 1	cl. 3	
5	0.001			005
15	0.01			015
20	0.03			020
30	0.05			030
50	0.01			050
70	0.01			070
100	0.02			100
150	0.03			150
200	0.04			200
250	0.05			250

333mV Secondary

Accuracy conforms to IEC61869-2 & IEEE/ANSI C57.13 meets the measuring range from 1 to 120 % of In

DIN RAIL MOUNTING Mount the bracket on the rail and install current transformer

PANEL MOUNTING Tighten screws on the hole to mount bracket and install current transformer

⚡ CAUTION: DANGER ⚡

HAZARD OF ELECTRIC SHOCK, EXPLOSION, OR ARC FLASH

- In order to guarantee safe operation of the transformer, please read and understand the instructions thoroughly. For your reference, see NFPA 70E in the USA, or applicable local codes.
- This equipment must only be installed and put into operation by qualified electrical personnel or appropriately trained individual.
- Before servicing the CTs, turn off all sources of power and use a properly rated voltage sensing device to check if the power is off.
- Current transformer secondary must be shorted or connected to a burden all times.
- The transformer (split core type) must not be operated when it is not fully closed or the installation is not completed.
- Rearrange all covers and protective devices before powering the equipment.

NOTICE

- This product is not intentionally made for safety applications.
- Make sure not to install this transformer in hazardous or classified areas.
- The installer is responsible for conformance to all applicable codes.
- Ignoring the warnings can lead to serious injury and/or cause damages.
- A qualified person is the one who is skilled and has knowledge about the construction and operation of this electrical equipment, and has received safety training to recognize and avoid the hazards involved. (NEC2011 Article 100)
- If this product is used in a way not specified by the manufacturer, the protection offered by the product may be impaired. No responsibility is taken by J&D Electronics for any consequences arising by not following this material properly