

SPLIT-CORE CURRENT TRANSDUCER

JC16F-XXX-VH

UL US E344623 CE RoHS



The Split-core Current Transducer, VH Series, is designed for energy management, with a convenient connection to electronic submeter. It may also be applied for current measurement in a system of distributed power line carriers (PLCs) or remote controls such as SCADA software for automation and supervision. Other applications include security and condition monitoring, load monitoring, in protection systems, and for predictive maintenance of conveyers, pumps or HVAC motors.

APPLICATIONS

- HVAC & Pumps
- Refrigeration
- Small Industrial Motors
- Fans
- Lighting

BENEFITS

- Small-size, light-weight
- Simple Installation
- Over-Voltage protection circuit is installed.

FEATURES

- Nylon-spring, output-terminal, secure locking hinge, one-touch structure makes easy to install to the existent equipments such as a power distribution boards.
- Isolated plastic case recognized according to UL94-V0
- UL/EN 61010-1 certified



NOTICE

- If you impact the core contact surface, internal core material could be damaged.
- Core contact surface is waterproofed, however if it gets rusty, you could reuse after removing rusts with spraying WD-40 or CRC5-56 on the rusted side.
- Do not use any other chemicals except WD-40 or CRC5-56 on housing or any other parts.
- Please use only the original output screws. Not recommended to replace it with anything else.
- Customizing output lead wire

HOW TO USE 1

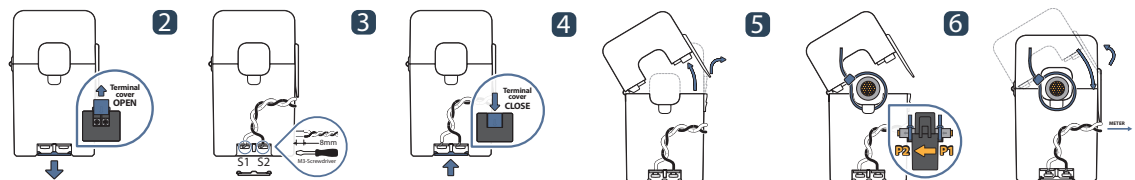

SPECIFICATION

(F=50/60Hz)

Model	JC16FXXX-VH / ϕ 16
Current Range(Arms)	5,10, 20, 25,50,100
Max. Allowable Current	100%(Continuous), 150%(1 min.)
Output	0~10V DC (Average)/0~Rated Current, 15V DC Limiter built-in
Accuracy / Linearity	\pm 2% FS. Dynamic Range 1:100 at 50/60Hz Sinewave
Output Impedance	23 k Ω
Sensor Supply Voltage	Self-Powered
Response Time	300ms
Output Ripple Voltage	Within 5% of Output Voltage
Output Terminals	2 x M3-Screw, with Terminals cover
Insulation Category	CATIII
Operating Condition	-20°C~+50°C, \leq 85%RH, No condensation, In-house & Any direction installable
Storage Condition	-30°C~+90°C, \leq 85%RH, No condensation

OUTPUT VOLTAGE DATA / OUTPUT IMPEDENCE

JC VH Average

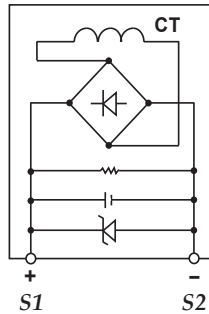
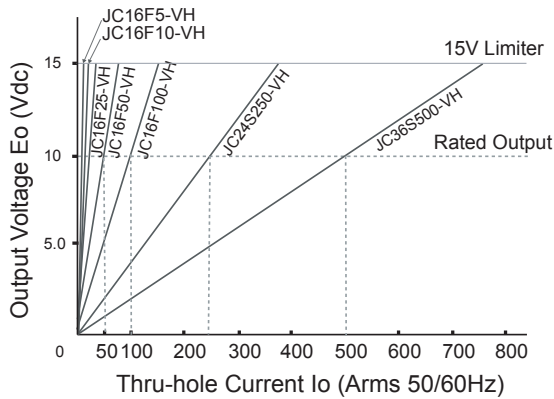

		JCØF-XXX-VH					
Std. Model	Ø	16					
	XXX	5	10	20	25	50	100
Output Impedance(kΩ)		23					

DIMENSIONS

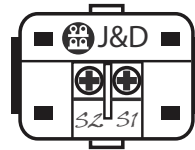
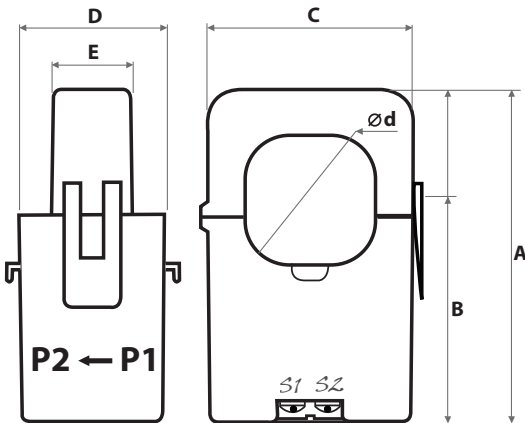

Unit : mm

Model	A	B	C	D	E	Ød
JC16F	55	41	29.5	31	19	16

APPLICATIONS

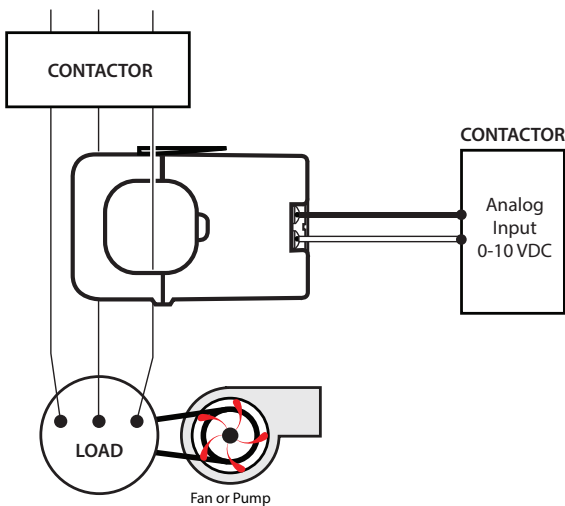

⚡ CAUTION: DANGER ⚠

HAZARD OF ELECTRIC SHOCK, EXPLOSION, OR ARC FLASH

- In order to guarantee safe operation of the transducer, please read and understand the instructions thoroughly. For your reference, see NFPA 70E in the USA, or applicable local codes.
- Certain parts of the module may carry hazardous live voltage when the transformers being operated (e.g. primary conductor, power supply).
- This equipment must only be installed and put into operation by qualified electrical personnel or appropriately trained individual.
- Before servicing the CTs, disconnect all sources of power and use a properly rated voltage sensing device to check if the power is off.
- Make sure to install the transducer only on insulated conductors.
- Do not depend on this product for voltage indication
- Use the product in a Pollution Degree 2. A Pollution Degree 2 environment must control conductive pollution and the possibility of condensation or high humidity. Regard the enclosure, thermal properties of the equipment, the proper use of ventilation and the relationship in surroundings.

NOTICE

- This product is not intentionally made for safety applications.
 - The installer is responsible for conformance to all applicable codes.
 - Ignoring the warnings could result in serious injury and/or cause damages.
 - Do not install and use this transducer in hazardous or classified areas.
 - If this product is used in a way not specified by the manufacturer, the protection offered by the product may be impaired.
- No responsibility is taken by J&D Electronics for any consequences arising by not following this material properly.