

# Split-Core Current Transducer IDCS10P

DC/AC current sensor, IDCSXXP series, applying with accurate laminating split-core technology and Open-Loop technology, has a strong durability and a good stability of error in low current and external vibration or shock.

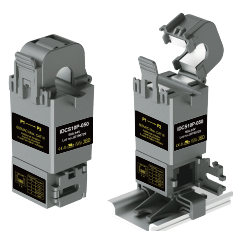

## Features

- One touch split core structure
- Isolation measurement CATIII
- Three Installation type: Panel mounting / DIN rail mounting / Cable tie mounting
- Insulating plastic case recognized under UL94-V0
- Complied with CE and RoHSIII

## Applications

- Uninterruptible Power Supplies (UPS)
- Monitoring and measuring Power supplies for Telecom
- Switched Mode Power Supplies (SMPS)
- Battery supplied applications
- Chopper / Inverter monitoring
- DC Power Meter

## Advantages

- Low power consumption with high accuracy
- Easy mounting by Split-core structure
- No insertion losses
- DC Immunity

## Specification

SPEC \ MODEL	IDCS10P-005	IDCS10P-010	IDCS10P-015	IDCS10P-020	IDCS10P-025	IDCS10P-030	IDCS10P-050
Rating Current	5A	10A	15A	20A	25A	30A	50A
Maximum Current	7.5A	15A	22.5A	30A	37.5A	45A	75A
Output Voltage	±4 V, 1% at rated current(F.S) RL=10KΩ						
Offset Voltage	±30 mV max less than						
Noise Level	< 20mVp-p						
Output Linearity	±1% rated current(F.S)						
Hysteresis (FS→0)	±15mV						
Power Supply	±15V (±5%) 25mA						
di/dt Response Time	2 μ sec (Typ.) at di/dt=F.S/μ sec						
Output voltage temperature coefficient	Typ ±0.1% / °C Max ±0.12% / °C				Typ ±0.08% / °C Max ±0.1% / °C		
Residual voltage temperature coefficient	±1.2mV / °C				±1mV / °C		
Insulation Withstand Voltage	AC 1500V / 1min.						
Insulation Category	CAT III 600VAC						
Insulation Resistance	DC 500V / 500MΩ max						
Operating Condition	-25°C~+75°C, 85% RH non-condensing						
Storage Condition	-35°C~+90°C, 85% RH non-condensing						

# Split-Core Current Transducer IDCS10P

## Graphs

Output Voltage Characteristic

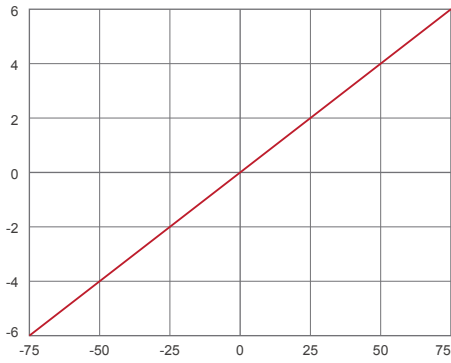

Frequency Characteristic

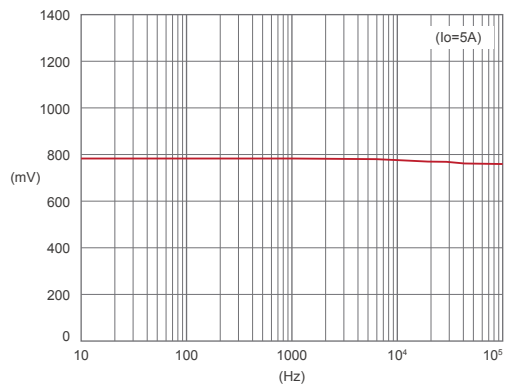

Output Wave-1

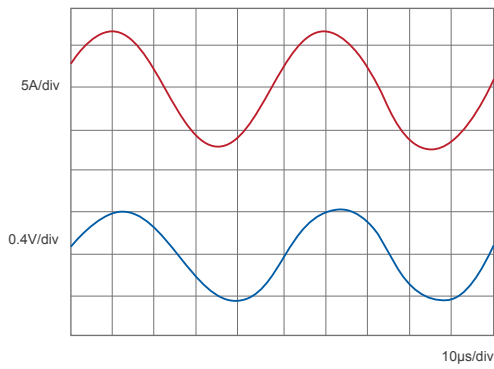

Output Wave-2

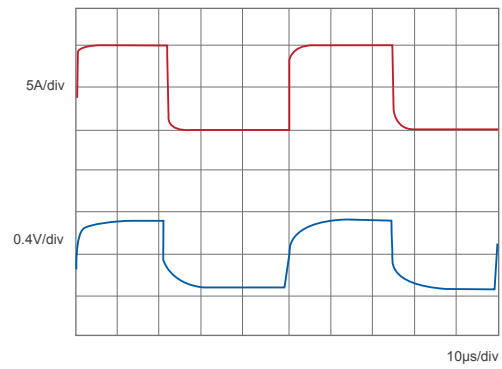

## How to use

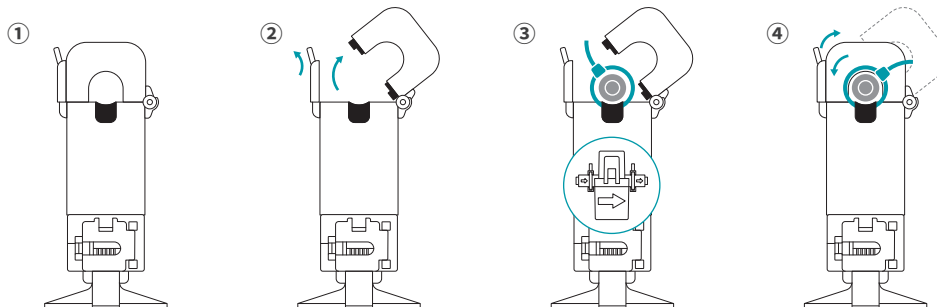

# Split-Core Current Transducer IDCS10P

## Dimensions IDCS10P (in mm)

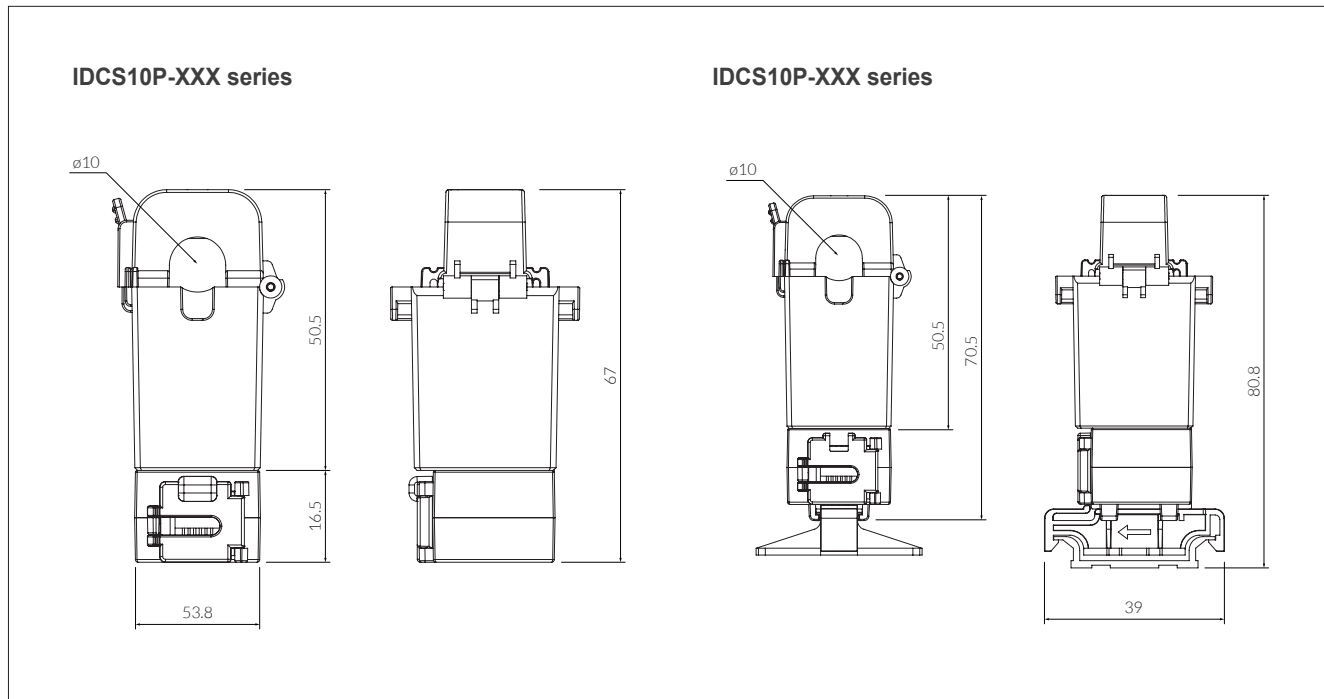

## Connection Diagram

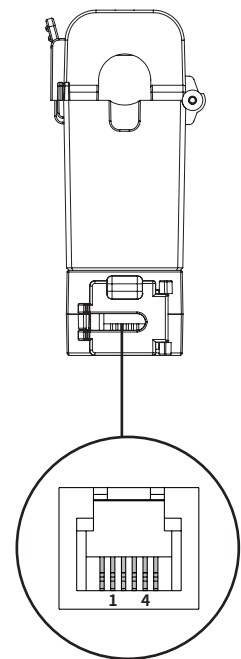

Connector

Manufacturer	Wisdom
Part Number	DS-1149-4

This product needs  $\pm 15V$  (+15V and -15V DC bi-polar power supply) as operating power supply. Even if the case of detecting current with only plus direction, it still  $\pm 15V$  needs. In any case, it is not possible to operate with only +15V

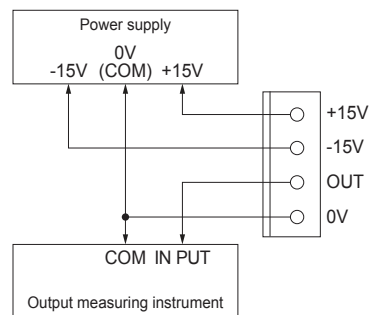

Terminal Pin	Function
1	+15 V
2	-15 V
3	OUTPUT
4	GND

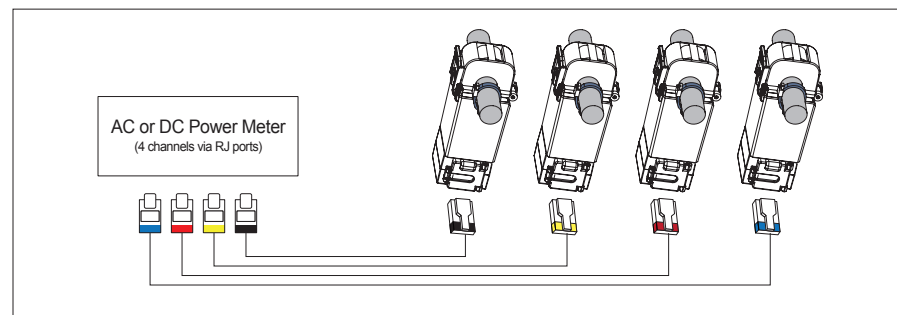

# Split-Core Current Transducer IDCS10P

## Mounting option

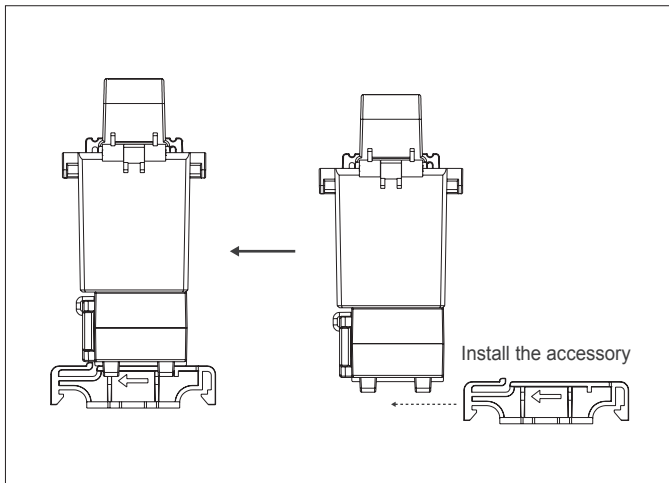

## DIN rail mounting

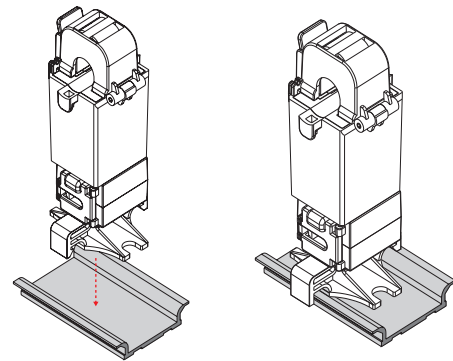

## Panel mounting

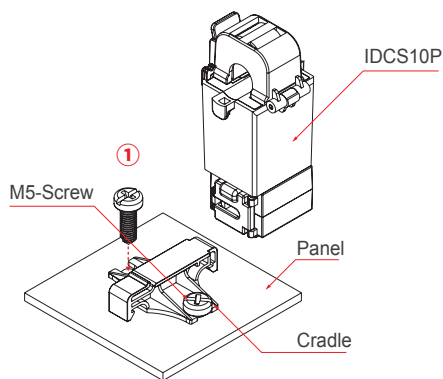

Place the cradle on the Panel and fix it via M5 screw.

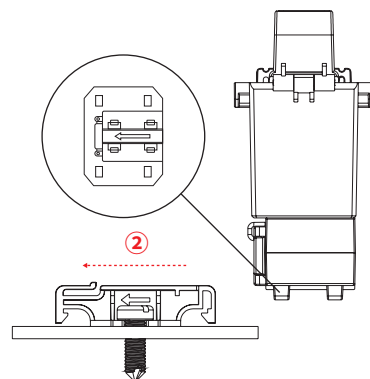

Install the product on the cradle, while matching the arrow direction of cradle and indication in the bottom of the product.

## Cable tie mounting

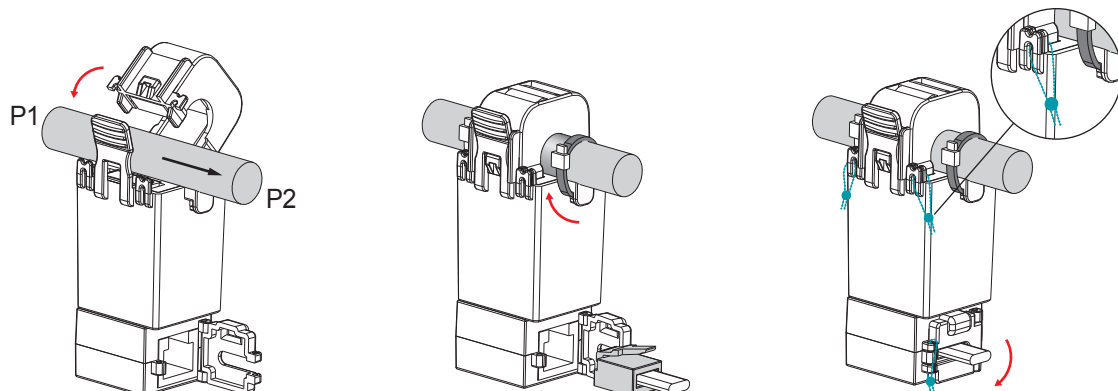

※ Sealing for metering standards  
(All types are available)

---

# Current Transducer IDCS10P

## Safety

The J&D CTs are UL/EN 61010-1, CE, RoHS compliant and certified, are also conformed up to Pollution degree 2, 600Vac CAT III rated devices.



Please be sure that Failure to follow these instructions can result in serious injury and/or cause damage. The transducer shall be used in electric/electronic equipment in accordance with the operating instructions of all related systems and component manufacturers with respect to applicable standards and safety requirements.

Follow corresponding national regulations and safe electrical work practices.

This equipment must only be installed and serviced by qualified personnel. And the qualified personnel is one who has skills and knowledge related to the construction and operation of this electrical equipment and installations, and has received safety training to recognize and avoid the hazards involved.

In addition, the installation and maintenance shall be done with the main power supply disconnected except if there are no hazardous live parts in or in close proximity to the system and if the applicable national regulations are fully observed.



When operating the transducer, there may be dangerous active voltages (e.g. primary conductor) in certain parts of the module. Users should make sure to take all necessary steps to protect against electric shock. The transducer is a built-in device containing conductive parts that are inaccessible after installation.

Therefore, a protective enclosure or additional insulation barrier is necessary.

Safe and trouble-free operation of this converter can only be guaranteed if transport, storage and installation are carried out correctly and operation and maintenance are carried out carefully.

## Remark

- $V_o$  is positive when  $I_p$  flows in the direction of the arrow. (o : output, p : primary current)
- Temperature of the primary conductor should not exceed 75°C(167°F).
- Dynamic performances (di/dt and delay time) are the best with a single bar when the primary hole is completely filled.
- By hysteresis of core, offset drift occurs proportionally to the over-current higher than rating value.
- The output value fluctuates upon the various factors, so it is recommended to use the current range higher than 5% of the rated current.
- Do not use the product over the maximum current continuously.

## Attention

Contact areas (air gap) must be kept clean (particle free) to ensure proper performance.