

IWL INDUSTRIAL
WHOLESALE
LIMITED

2023
PRODUCT
CATALOGUE



FIREBIRD

INDUSTRIAL CONSUMABLES



View our industrial supplies online
firebirdnz.co.nz

Get in Touch...
ian@indwhl.co.nz
027 666 5566

Fire Bird Abrasives

Zirconium Flap Discs



Zirconium Flap Discs	Size / Grit	Wrap	Box	Carton
ABFDFBZ115P36	115mm x 22.2 x 36P	5	10	100
ABFDFBZ115P60	115mm x 22.2 x 60P	5	10	100
ABFDFBZ115P80	115mm x 22.2 x 80P	5	10	100
ABFDFBZ125P36	125mm x 22.2 x 36P	5	10	100
ABFDFBZ125P60	125mm x 22.2 x 60P	5	10	100
ABFDFBZ125P80	125mm x 22.2 x 80P	5	10	100
ABFDFBZ125P120	125mm x 22.2 x 120P	5	10	100

Ceramic Flap Discs

Ceramic Flap Discs	Size / Grit	Wrap	Box	Carton
ABFDFBC125P36	125mm x 22.2 x 36P	5	10	100
ABFDFBC125P60	125mm x 22.2 x 60P	5	10	100
ABFDFBC125P80	125mm x 22.2 x 80P	5	10	100



Ceramic Fibre Discs

Part Number	Description	Box
ABFICFB125P80	Ceramic Fibre Discs 125 X P80	25
ABFICFB125P60	Ceramic Fibre Discs 125 X P60	25
ABFICFB125P24	Ceramic Fibre Discs 125 X P24	25
ABFICFB125P36	Ceramic Fibre Discs 125 X P36	25

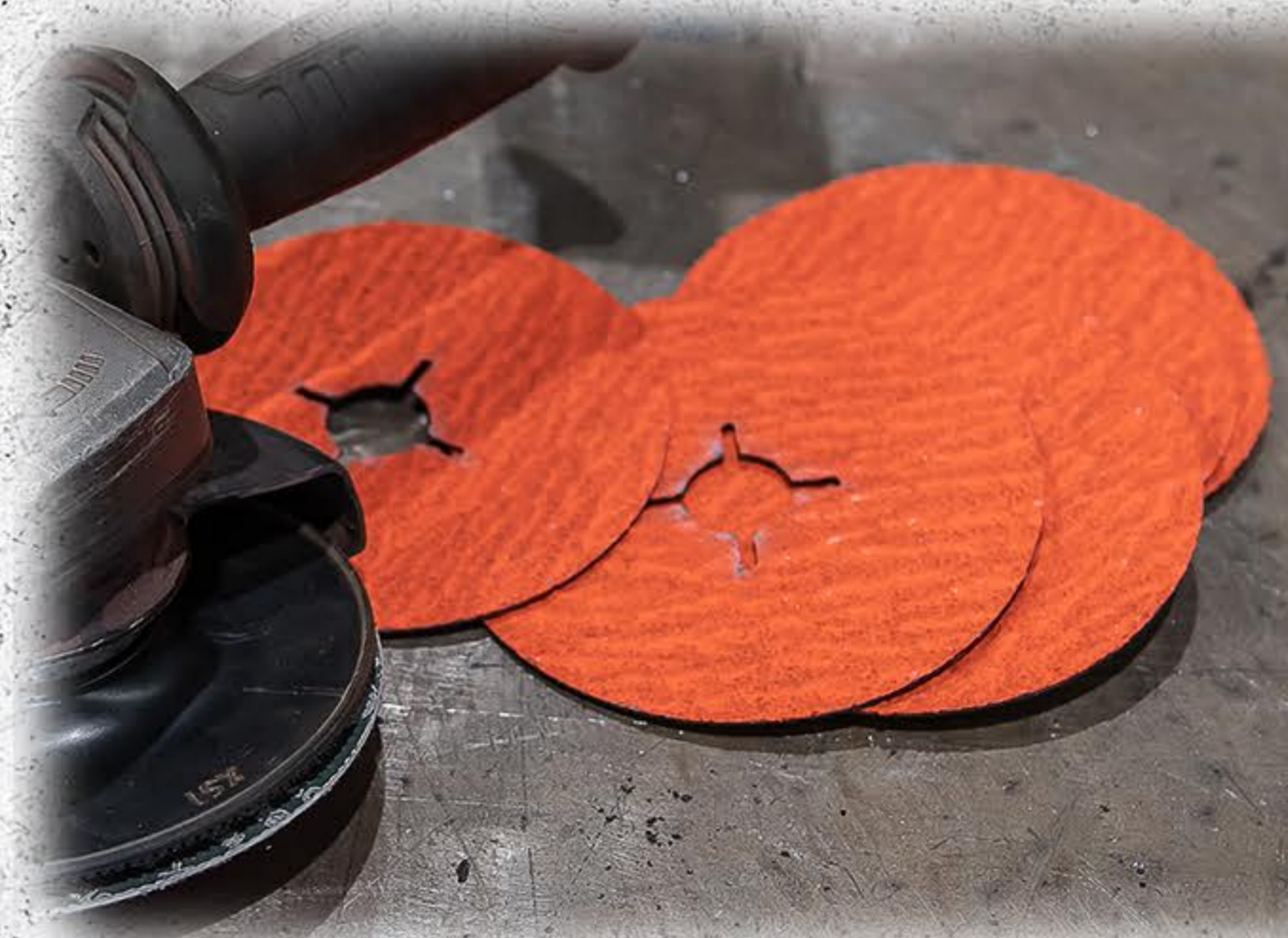
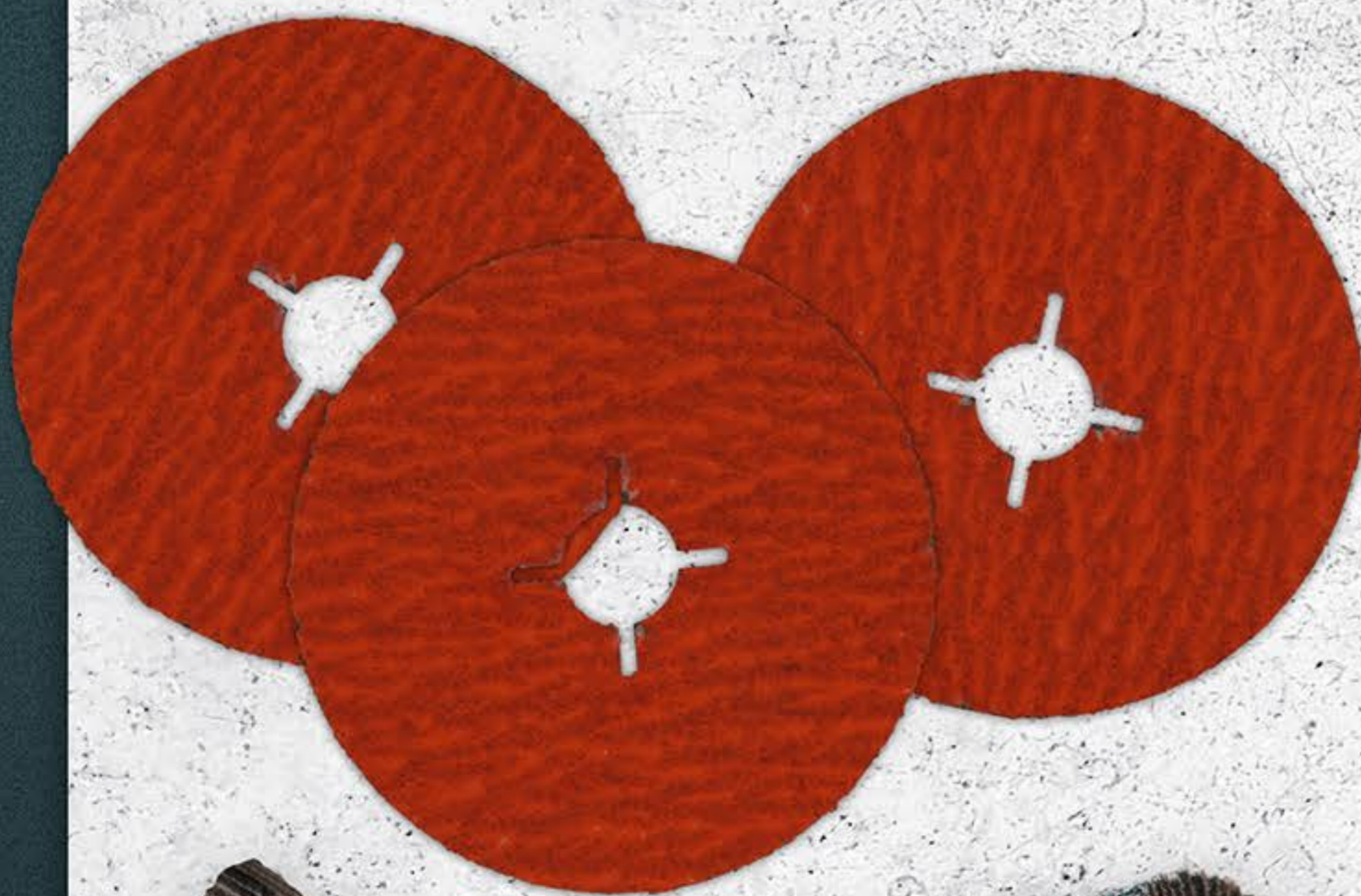

Zirconia Flap Wheels

Part Number	Description
ABFWFB40X25X6-60P	40mm x 25 x 6mm shaft 60P
ABFWFB40X25X6-80P	40mm x 25 x 6mm shaft 80P
ABFWFB40X25X6-120P	40mm x 25 x 6mm shaft 120P
ABFWFB50X25X6-60P	50mm x 25 x 6mm shaft 60P
ABFWFB50X25X6-80P	50mm x 25 x 6mm shaft 80P
ABFWFB50X25X6-120P	50mm x 25 x 6mm shaft 120P



Fire Bird Abrasives



Cutting Discs

Fire Bird metal cut-off discs are designed for fast performance and long life when cutting mild steels, sheet metals and stainless steels. Perfect for cutting profiles and pipes. Designed to perform burr free cutting. The latest generation of high performance cutting discs.

Part Number	Description	Wrap	Box	Carton
ABCDFB115X1	115 X 1 X 22.2	10	100	400
ABCDFB125X1	125 X 1 X 22.2	10	50	400
ABCDFB125X1PK25	125 X 1 Metal Tins 25pk			16 tins
ABCDFB180X1.9	180 X 1.9 X 22.2	10	50	100
ABCDFB230X1.9	230 X 1.9 X 22.2	10	50	100
ABCDFB230X3.2	230 X 3.2 X 22.2	10	50	100

Grinding Discs

Fire Bird grinding disc designed for fast removal of material made to be used on mild steels, sheet metals and stainless steel. Designed to be fast and aggressive with a high material removal rate. Maintains an aggressive grinding edge with less wear and a dramatically longer life than standard aluminum oxide disks.

Part Number	Description	Wrap	Box	Carton
ABGDFB115	115 X 6 X 22.2	5	30	120
ABGDFB125	125 X 6 X 22.2	5	30	120
ABGDFB180	180 X 6 X 22.2	5	20	40
ABGDFB230	230 X 6 X 22.2	5	20	40



Fire Bird Brushes

4 Row Wire Scratch Brushes

Stainless Steel



Mild Steel



Fire Bird hand brushes are ideal for rust removal, paint and dirt from any kind of surface. Stainless steel brushes are best suited when working on stainless, aluminum and other nonferrous metals to eliminate the chance of after-rust appearing on the work surface.

Part Number	Name	Sold each	Box	Carton
BRFBHSS4R	4 ROW STAINLESS STEEL	yes	10	100
BRFBHMS4R	4 ROW MILD STEEL	yes	10	100
BRFBSBSS	CRIMPED STAINLESS STEEL	yes	10	100
BRFBSBMS	CRIMPED MILD STEEL	yes	10	100

Crimped Wire Scratch Brushes

Stainless Steel



Mild Steel



Angle Grinder Brushes

Fire Bird wire brushes are an excellent choice for scraping corrosion and decay, dust, slag, weld splatter, and other unwanted surface particles with angle grinders. The Fire Bird Wire wheels for Grinders are ideal for different types of handheld grinders. The Wire Brush is an abrasive tool used for rust cleaning and paint removal.

Part Number	Name	sold each	carton
BRFBTB75X14	CUP BRUSH TWISTED 75MM	yes	30
BRFBTB100X14	CUP BRUSH TWISTED 100MM	yes	20
BRFBTB125X14	CUP BRUSH TWISTED 125MM	yes	30
BRFBCB75X14	CUP BRUSH CRIMPED 75MM	yes	30
BRFBCB100X14	CUP BRUSH CRIMPED 100MM	yes	20
BRFBCB125X14	CUP BRUSH CRIMPED 125MM	yes	30
BRFBBCB100X14	TWISTED BEVEL BRUSH 100MM	yes	30
BRFBBCB115X14	TWISTED BEVEL BRUSH 115MM	yes	30
BRFBBCB125X14	TWISTED BEVEL BRUSH 125MM	yes	30

Twisted Knot Cup Brush



Twisted Knot Bevel Brush



Crimped Wire Cup Brush



Fire Bird Burrs

Double Cut Tungsten Carbide Burrs

Fire Bird Tungsten carbide burrs are used for rapidly shaping, cutting, removal of sharp edges, burrs and smoothing welds. They're able to be used on a wide range of materials including stainless steel, aluminum and cast iron, acrylics, fibreglass and plastics. The 'double cut' style will leave a smoother finish than single cut due to producing smaller chips as they cut away the material.



A - Cylinder



C - Ball Cylinder



D - Ball



L - Rounded Cone



H - Flame



W - Rounded Cylinder

Part Number	Description
CBFBAX0616M06	6mm x 16mm x M6 SHAPE A
CBFBAX0820M06	8mm x 20 mm x M6 SHAPE A
CBFBAX1020M06	10mm x 20mm x M6 SHAPE A
CBFBAX1225M06	12mm x 25mm x M6 SHAPE A
CBFBCX0616M06	6mm x 16mm x M6 SHAPE C
CBFBCX0820M06	8mm x 20mm x M6 SHAPE C
CBFBCX1020M06	10mm x 20mm x M6 SHAPE C
CBFBCX1225M06	12mm x 25mm x M6 SHAPE C
CBFBDX0605M06	6mm x 05mm x M6 SHAPE D
CBFBDX0807M06	8mm x 07mm x M6 SHAPE D
CBFBDX1009M06	10mm x 09mm x M6 SHAPE D
CBFBDX1211M06	12mm x 11mm x M6 SHAPE D
CBFBHX0618M06	6mm x 18mm x M6 SHAPE H
CBFBHX0820M06	8mm x 20mm x M6 SHAPE H
CBFBHX1025M06	10mm x 25mm x M6 SHAPE H
CBFBHX1232M06	12mm x 32mm x M6 SHAPE H
CBFBLX0616M06	6mm x 16mm x M6 SHAPE L
CBFBLX0822M06	8mm x 22mm x M6 SHAPE L
CBFBLX1025M06	10mm x 25mm x M6 SHAPE L
CBFBLX1228M06	12mm x 28mm x M6 SHAPE L
CBFBWX1018M06	10mm x 18mm x M6 SHAPE W
CBFBWX1222M06	12mm x 22mm x M6 SHAPE W
CBFBWX1422M06	14mm x 22mm x M6 SHAPE W



Five Piece Set - CFBKIT-5PC



Fire Bird Drills

SDS+ Concrete Drill Bits

Fire Bird SDS+ Cross-head Concrete Drill Bits are designed for smooth drilling, maximum spoil/material removal and long life. They have four tungsten carbide cutting edges to penetrate the hardest of masonry materials. Made to be used on concrete, brick, block and a wide range of other masonry materials.

7pc SDS+ Concrete Drill Bit Set



Part Number	Size	Sold Each
DTFBSDSCH-M5X110	5mm x110mm	Yes
DTFBSDSCH-M5X160	5mm x160mm	Yes
DTFBSDSCH-M6.5X160	6.5mm x160mm	Yes
DTFBSDSCH-M6X110	6mm x110mm	Yes
DTFBSDSCH-M6X160	6mm x160mm	Yes
DTFBSDSCH-M6X260	6mm x 260mm	Yes
DTFBSDSCH-M8X110	8mm x110mm	Yes
DTFBSDSCH-M8X160	8mm x160mm	Yes
DTFBSDSCH-M8X260	8mm x260mm	Yes
DTFBSDSCH-M10X160	10mm x160mm	Yes
DTFBSDSCH-M10X260	10mm 260mm	Yes
DTFBSDSCH-M10X460	10mm x460mm	Yes
DTFBSDSCH-M12.5X160	12.5mm x160mm	Yes
DTFBSDSCH-M12.5X260	12.5mm x260mm	Yes
DTFBSDSCH-M12X160	12mm x160mm	Yes
DTFBSDSCH-M12X260	12mm x260mm	Yes
DTFBSDSCH-M12X400	12mm x400mm	Yes
DTFBSDSCH-M12X460	12mm x460mm	Yes
DTFBSDSCH-M13X260	13mm x260mm	Yes
DTFBSDSCH-M13X400	13mm x400mm	Yes
DTFBSDSCH-M14X260	14mm x 260mm	Yes
DTFBSDSCH-M16X260	16mm x 260mm	Yes
DTFBSDSCH-M18X260	18mm x 260mm	Yes
DTFBSDSCH-M20X260	20mm x260mm	Yes
DTFBSDSCH-M22X260	22mm x 260mm	Yes
DTFBSDSCH-M24X260	24mm x260mm	Yes
DTFBSDSCH-M26X260	26mm x260mm	Yes



Part Number	Description	Sold Each
DTFBSDS-7PC KIT	SDS 7PC SDS Concrete Drill Bit set	Yes

Spiral Step Drill Bits

Fire Bird gold coloured step drill bits are Tin coated, high speed steel M2. Drills up to 32mm in different thickness and materials like Non-ferrous metals, sheet steel, plastic and stainless steel up to 3mm thick.

Gold Series	Size	Sold each
DTFBSDM2-4X12MMG	Spiral Step Drill 4-12mm	Yes
DTFBSDM2-4X20MMG	Spiral Step Drill 4-20mm	Yes
DTFBSDM2-6X32MMG	Spiral Step Drill 6-32mm	Yes
DTFBSDM2-3PCG	3pc Gold Spiral Step Drill Set	Yes

Fire Bird black coloured step spiral drill bits are, drop forged, heat treated high speed steel with titanium nitride coating for a longer life time. Drills up to 32mm in different thickness and materials like sheet metal, iron plate, aluminum plate, brass, wood, plastic, stainless steel up to 3mm.

Black Series	Size	Sold each
DTFBSDM2-4X12MMB	Spiral Step Drill 4-12mm	Yes
DTFBSDM2-4X20MMB	Spiral Step Drill 4-20mm	Yes
DTFBSDM2-6X32MMB	Spiral Step Drill 6-32mm	Yes
DTFBSDM2-3PCB	3pc Black Spiral Step Drill Set	Yes



Fire Bird Annular Cutters

Fire Bird annular cutters (also called a core drill, core cutter, broach cutter, trepanning drill, hole saw, or cup-type cutter) are a form of core drill used to create holes in metal. An annular cutter, named after the annulus shape, cuts only a groove at the periphery of the hole and leaves a solid core or slug at the center. Fire Bird Annular Cutters are quality high speed steel with vacuum quenching and a tempering process, effectively improve the wear resistance of the cutting edge. Multilayer cutter geometry, improve the centering and chip removal, many types of product performance can drill to meet the needs of the different materials.



Part Number	Size
DTFBAC-25-PIN	Centering Pin 25mm
DTFBACM2-25-12MM	12mm x 25mm
DTFBACM2-25-13MM	13mm x 25mm
DTFBACM2-25-14MM	14mm x 25mm
DTFBACM2-25-15MM	15mm x 25mm
DTFBACM2-25-16MM	16mm x 25mm
DTFBACM2-25-17MM	17mm x 25mm
DTFBACM2-25-18MM	18mm x 25mm
DTFBACM2-25-19MM	19mm x 25mm
DTFBACM2-25-20MM	20mm x 25mm
DTFBACM2-25-21MM	21mm x 25mm
DTFBACM2-25-22MM	22mm x 25mm
DTFBACM2-25-23MM	23mm x 25mm
DTFBACM2-25-24MM	24mm x 25mm
DTFBACM2-25-25MM	25mm x 25mm
DTFBACM2-25-26MM	26mm x 25mm
DTFBACM2-25-27MM	27mm x 25mm
DTFBACM2-25-28MM	28mm x 25mm
DTFBACM2-25-29MM	29mm x 25mm
DTFBACM2-25-30MM	30mm x 25mm
DTFBACM2-25-31MM	31mm x 25mm
DTFBACM2-25-32MM	32mm x 25mm
DTFBACM2-25-33MM	33mm x 25mm
DTFBACM2-25-34MM	34mm x 25mm
DTFBACM2-25-35MM	35mm x 25mm
DTFBACM2-25-36MM	36mm x 25mm
DTFBACM2-25-37MM	37mm x 25mm
DTFBACM2-25-38MM	38mm x 25mm
DTFBACM2-25-39MM	39mm x 25mm
DTFBACM2-25-40MM	40mm x 25mm
DTFBACM2-25-41MM	41mm x 25mm
DTFBACM2-25-42MM	42mm x 25mm
DTFBACM2-25-43MM	43mm x 25mm
DTFBACM2-25-44MM	44mm x 25mm
DTFBACM2-25-45MM	45mm x 25mm
DTFBACM2-25-46MM	46mm x 25mm
DTFBACM2-25-47MM	47mm x 25mm
DTFBACM2-25-48MM	48mm x 25mm
DTFBACM2-25-49MM	49mm x 25mm
DTFBACM2-25-50MM	50mm x 25mm
DTFBACM2-25-51MM	51mm x 25mm
DTFBACM2-25-52MM	52mm x 25mm

Part Number	Size
DTFBAC-50-PIN	Centering Pin 50mm
DTFBACM2-50-12MM	12mm x 50mm
DTFBACM2-50-13MM	13mm x 50mm
DTFBACM2-50-14MM	14mm x 50mm
DTFBACM2-50-15MM	15mm x 50mm
DTFBACM2-50-16MM	16mm x 50mm
DTFBACM2-50-17MM	17mm x 50mm
DTFBACM2-50-18MM	18mm x 50mm
DTFBACM2-50-19MM	19mm x 50mm
DTFBACM2-50-20MM	20mm x 50mm
DTFBACM2-50-21MM	21mm x 50mm
DTFBACM2-50-22MM	22mm x 50mm
DTFBACM2-50-23MM	23mm x 50mm
DTFBACM2-50-24MM	24mm x 50mm
DTFBACM2-50-25MM	25mm x 50mm
DTFBACM2-50-26MM	26mm x 50mm
DTFBACM2-50-27MM	27mm x 50mm
DTFBACM2-50-28MM	28mm x 50mm
DTFBACM2-50-29MM	29mm x 50mm
DTFBACM2-50-30MM	30mm x 50mm
DTFBACM2-50-31MM	31mm x 50mm
DTFBACM2-50-32MM	32mm x 50mm
DTFBACM2-50-33MM	33mm x 50mm
DTFBACM2-50-34MM	34mm x 50mm
DTFBACM2-50-35MM	35mm x 50mm
DTFBACM2-50-36MM	36mm x 50mm
DTFBACM2-50-37MM	37mm x 50mm
DTFBACM2-50-38MM	38mm x 50mm
DTFBACM2-50-39MM	39mm x 50mm
DTFBACM2-50-40MM	40mm x 50mm
DTFBACM2-50-41MM	41mm x 50mm
DTFBACM2-50-42MM	42mm x 50mm
DTFBACM2-50-43MM	43mm x 50mm
DTFBACM2-50-44MM	44mm x 50mm
DTFBACM2-50-45MM	45mm x 50mm
DTFBACM2-50-46MM	46mm x 50mm
DTFBACM2-50-47MM	47mm x 50mm
DTFBACM2-50-48MM	48mm x 50mm
DTFBACM2-50-49MM	49mm x 50mm
DTFBACM2-50-50MM	50mm x 50mm
DTFBACM2-50-51MM	51mm x 50mm
DTFBACM2-50-52MM	52mm x 50mm

Part Number	Annular Cutter Sets in Steel Case
DTFBACM2-25-4PCS	4PC (12, 14, 18 & 22mm) 25mm
DTFBACM2-25-6PCS	6PC (12, 14, 17, 18, 22 & 24mm) 25mm
DTFBAC-CASE	BUILD YOUR OWN SET (Holds Sizes 14 – 26mm)



Fire Bird High Speed M2 Drill Bits

Fire Bird high speed drill bits are made with accuracy and durability for drilling steel, wood, plastics and a wide range of other materials. Ideal for fixing holes, tapping & clearance and perfect for automotive maintenance, engineering, workshops, plumbing & electrical applications. The split point tip is an extra facet ground on to the end of the drill bit causing it to be more pointed rather than having a straight edge, which assists in centering the drill accurately and reducing wander. The combination of 135° angle and split point design improves penetration rates for faster drilling. Fire Bird reduced shank drill bits have three flat edges ground into the shank, which eliminates the chance of slipping in the jaws of a chuck. Each drill bit is laser etched for fast and lasting size identification.

135° Split Point 1-13mm

Code	Size	Sold Each	Pack Size
DTFBDB135M2-1MM	1.0mm	yes	10
DTFBDB135M2-2.5MM	2.5mm	yes	10
DTFBDB135M2-2MM	2.0mm	yes	10
DTFBDB135M2-3.2MM	3.2mm	yes	10
DTFBDB135M2-3.3MM	3.3mm	yes	10
DTFBDB135M2-3.5MM	3.5mm	yes	10
DTFBDB135M2-3MM	3.0mm	yes	10
DTFBDB135M2-4.1MM	4.1mm	yes	10
DTFBDB135M2-4.2MM	4.2mm	yes	10
DTFBDB135M2-4.5MM	4.5mm	yes	10
DTFBDB135M2-4.8MM	4.8mm	yes	10
DTFBDB135M2-4.9MM	4.9mm	yes	10
DTFBDB135M2-4MM	4.0mm	yes	10
DTFBDB135M2-5.5MM	5.5mm	yes	10
DTFBDB135M2-5MM	5.0mm	yes	10
DTFBDB135M2-6.5MM	6.5mm	yes	10
DTFBDB135M2-6.8MM	6.8mm	yes	10
DTFBDB135M2-6MM	6.0mm	yes	10
DTFBDB135M2-7.5MM	7.5mm	yes	10
DTFBDB135M2-7MM	7.0mm	yes	10
DTFBDB135M2-8.5MM	8.5mm	yes	10
DTFBDB135M2-8MM	8.0mm	yes	10
DTFBDB135M2-9.5MM	9.5mm	yes	5
DTFBDB135M2-9MM	9.0mm	yes	5
DTFBDB135M2-10MM	10.0mm	yes	5
DTFBDB135M2-10.2MM	10.2mm	yes	5
DTFBDB135M2-10.5MM	10.5mm	yes	5
DTFBDB135M2-11MM	11.0mm	yes	5
DTFBDB135M2-11.5MM	11.5mm	yes	5
DTFBDB135M2-12MM	12.0mm	yes	5
DTFBDB135M2-12.5MM	12.5mm	yes	5
DTFBDB135M2-13MM	13.0mm	yes	5
Double Ended Series:			
DTFBDBDE135M2-3MM	3.0mm	yes	10
DTFBDBDE135M2-4.1MM	4.1mm	yes	10
DTFBDBDE135M2-4.9MM	4.9mm	yes	10

HSS Drill Bit Kits

DTFBDB135M2-KIT1-6.5mm	HSS Drill Kit 1-6.5MM
DTFBDB135M2-KIT1-13mm	HSS Drill Kit 1-13MM

1/2" Reduced Shank 13.5-25mm

Code	Size	Sold Each	Pack Size
DTFBDB118M2-13.5MMRS	13.5mm	yes	1
DTFBDB118M2-14.0MMRS	14.0mm	yes	1
DTFBDB118M2-14.5MMRS	14.5mm	yes	1
DTFBDB118M2-15.0MMRS	15.0mm	yes	1
DTFBDB118M2-15.5MMRS	15.5mm	yes	1
DTFBDB118M2-16.0MMRS	16.0mm	yes	1
DTFBDB118M2-16.5MMRS	16.5mm	yes	1
DTFBDB118M2-17.0MMRS	17.0mm	yes	1
DTFBDB118M2-17.5MMRS	17.5mm	yes	1
DTFBDB118M2-18.0MMRS	18.0mm	yes	1
DTFBDB118M2-18.5MMRS	18.5mm	yes	1
DTFBDB118M2-19.0MMRS	19.0mm	yes	1
DTFBDB118M2-19.5MMRS	19.5mm	yes	1
DTFBDB118M2-20.0MMRS	20.0mm	yes	1
DTFBDB118M2-20.5MMRS	20.5mm	yes	1
DTFBDB118M2-21.0MMRS	21.0mm	yes	1
DTFBDB118M2-21.5MMRS	21.5mm	yes	1
DTFBDB118M2-22.0MMRS	22.0mm	yes	1
DTFBDB118M2-22.5MMRS	22.5mm	yes	1
DTFBDB118M2-23.0MMRS	23.0mm	yes	1
DTFBDB118M2-23.5MMRS	23.5mm	yes	1
DTFBDB118M2-24.0MMRS	24.0mm	yes	1
DTFBDB118M2-24.5MMRS	24.5mm	yes	1
DTFBDB118M2-25.0MMRS	25.0mm	yes	1



Fire Bird HSS Taps

HSS Straight Flute Short Machine and Hand Taps

Fire Bird taps are ideal for creating new threads in a wide variety of materials. HSS taps provide a high hardness to toughness ratio, compressive and tensile strength, good abrasion resistance and resistance to micro-chipping, ensuring a long tool life.

TAPER TAPS have a lead of eight threads and are used as a starting tap in difficult or high precision holes.

INTERMEDIATE TAPS have a lead of four threads and are used in most general purpose applications to cut a thread true to a pre-drilled pilot hole.

BOTTOMING TAPS have a lead of two threads and are used to ensure minimum thread run-out when tapping to the bottom of a blind hole. Bottoming Taps are typically preceded by the use of a Taper or Intermediate Tap.



Code	HSS Taper Tap Size
DTFBTTM2-M3X0.5P	M3 x 0.5P
DTFBTTM2-M4X0.7P	M4 x 0.7P
DTFBTTM2-M5X0.8P	M5 x 0.8P
DTFBTTM2-M6X1.0P	M6 x 1.0P
DTFBTTM2-M8X1.25P	M8 x 1.25P
DTFBTTM2-M10X1.5P	M10 x 1.5P
DTFBTTM2-M12X1.75P	M12 x 1.75P
DTFBTTM2-M14X2.0P	M14 x 2.0P
DTFBTTM2-M16X2.0P	M16 x 2.0P
DTFBTTM2-M18X2.5P	M18 x 2.5P
DTFBTTM2-M20X2.5P	M20 x 2.5P
DTFBTTM2-MF8X1.0P	Metric Fine M8 x 1.0P
DTFBTTM2-MF10X1.0P	Metric Fine M10 x 1.0P
DTFBTTM2-MF10X1.25P	Metric Fine M10 x 1.25P
DTFBTTM2-MF12X1.25P	Metric Fine M12 x 1.25P
DTFBTTM2-MF12X1.5P	Metric Fine M12 x 1.5P
DTFBTTM2-MF14X1.25P	Metric Fine M14 x 1.25P
DTFBTTM2-MF14X1.5P	Metric Fine M14 x 1.5P
DTFBTTM2-MF16X1.5P	Metric Fine M16 x 1.5P
DTFBTTM2-MF20X1.5P	Metric Fine M20 x 1.5P

Code	HSS Intermediate Tap Size
DTFBTIM2-M3X0.5P	M3 x 0.5P
DTFBTIM2-M4X0.7P	M4 x 0.7P
DTFBTIM2-M5X0.8P	M5 x 0.8P
DTFBTIM2-M6X1.0P	M6 x 1.0P
DTFBTIM2-M8X1.25P	M8 x 1.25P
DTFBTIM2-M10X1.5P	M10 x 1.5P
DTFBTIM2-M12X1.75P	M12 x 1.75P
DTFBTIM2-M14X2.0P	M14 x 2.0P
DTFBTIM2-M16X2.0P	M16 x 2.0P
DTFBTIM2-M18X2.5P	M18 x 2.5P
DTFBTIM2-M20X2.5P	M20 x 2.5P
DTFBITM2-MF8X1.0P	Metric Fine M8 x 1.0P
DTFBITM2-MF10X1.0P	Metric Fine M10 x 1.0P
DTFBITM2-MF10X1.25P	Metric Fine M10 x 1.25P
DTFBITM2-MF12X1.25P	Metric Fine M12 x 1.25P
DTFBITM2-MF12X1.5P	Metric Fine M12 x 1.5P
DTFBITM2-MF14X1.25P	Metric Fine M14 x 1.25P
DTFBITM2-MF14X1.5P	Metric Fine M14 x 1.5P
DTFBITM2-MF16X1.5P	Metric Fine M16 x 1.5P
DTFBITM2-MF20X1.5P	Metric Fine M20 x 1.5P

Code	HSS Bottoming Tap Size
DTFBTBM2-M3X0.5P	M3 x 0.5P
DTFBTBM2-M4X0.7P	M4 x 0.7P
DTFBTBM2-M5X0.8P	M5 x 0.8P
DTFBTBM2-M6X1.0P	M6 x 1.0P
DTFBTBM2-M8X1.25P	M8 x 1.25P
DTFBTBM2-M10X1.5P	M10 x 1.5P
DTFBTBM2-M12X1.75P	M12 x 1.75P
DTFBTBM2-M14X2.0P	M14 x 2.0P
DTFBTBM2-M16X2.0P	M16 x 2.0P
DTFBTBM2-M18X2.5P	M18 x 2.5P
DTFBTBM2-M20X2.5P	M20 x 2.5P
DTFBBTM2-MF8X1.0P	Metric Fine M8 x 1.0P
DTFBBTM2-MF10X1.0P	Metric Fine M10 x 1.0P
DTFBBTM2-MF10X1.25P	Metric Fine M10 x 1.25P
DTFBBTM2-MF12X1.25P	Metric Fine M12 x 1.25P
DTFBBTM2-MF12X1.5P	Metric Fine M12 x 1.5P
DTFBBTM2-MF14X1.25P	Metric Fine M14 x 1.25P
DTFBBTM2-MF14X1.5P	Metric Fine M14 x 1.5P
DTFBBTM2-MF16X1.5P	Metric Fine M16 x 1.5P
DTFBBTM2-MF20X1.5P	Metric Fine M20 x 1.5P

Code	3pc Tap Set Size
DTFBT3PCM2-M3X0.5P	M3 x 0.5P
DTFBT3PCM2-M4X0.7P	M4 x 0.7P
DTFBT3PCM2-M5X0.8P	M5 x 0.8P
DTFBT3PCM2-M6X1.0P	M6 x 1.0P
DTFBT3PCM2-M8X1.25P	M8 x 1.25P
DTFBT3PCM2-M10X1.5P	M10 x 1.5P
DTFBT3PCM2-M12X1.75P	M12 x 1.75P
DTFBT3PCM2-M14X2.0P	M14 x 2.0P
DTFBT3PCM2-M16X2.0P	M16 x 2.0P
DTFBT3PCM2-M18X2.5P	M18 x 2.5P
DTFBT3PCM2-M20X2.5P	M20 x 2.5P
DTFBT14PCM2-M3-M12	14Pc M3-M12 Drill & Tap Set



Fasteners



Zinc Plated 8.8 Bolts

Product Name	Code	BAG QTY	6-10MM 1,030pc KIT	6-12MM 1,420pc KIT	FARMERS 2,050pc KIT	WORKSHOP 3,154pc KIT	HEAVY WORKSHOP 5,568pc KIT
M6x16 Zinc Plated 8.8 Bolt	BNHTZM6X16	20	20		40	20	40
M6x20 Zinc Plated 8.8 Bolt	BNHTZM6X20	20	20	20		20	40
M6x25 Zinc Plated 8.8 Bolt	BNHTZM6X25	20	20	20	40	20	40
M6x30 Zinc Plated 8.8 Bolt	BNHTZM6X30	20	20	20	40	20	40
M6x40 Zinc Plated 8.8 Bolt	BNHTZM6X40	20	20	20	40	20	40
M6x60 Zinc Plated 8.8 Bolt	BNHTZM6X60	20	20			20	40
M6x35 Zinc Plated 8.8 Bolt	BNHTZM6X35	20				20	40
M6x45 Zinc Plated 8.8 Bolt	BNHTZM6X45	20				20	40
M6x50 Zinc Plated 8.8 Bolt	BNHTZM6X50	20		20	40	20	40
M6x70 Zinc Plated 8.8 Bolt	BNHTZM6X70	20				20	40
M6x80 Zinc Plated 8.8 Bolt	BNHTZM6X80	20			40	20	40
M6x90 Zinc Plated 8.8 Bolt	BNHTZM6X90	20				20	40
M6x100 Zinc Plated 8.8 Bolt	BNHTZM6X100	20				20	40

Product Name	Code	BAG QTY	6-10MM 1,030pc KIT	6-12MM 1,420pc KIT	FARMERS 2,050pc KIT	WORKSHOP 3,154pc KIT	HEAVY WORKSHOP 5,568pc KIT
M8x16 Zinc Plated 8.8 Bolt	BNHTZM8X16	20	20		40	20	40
M8x20 Zinc Plated 8.8 Bolt	BNHTZM8X20	20	20			20	40
M8x25 Zinc Plated 8.8 Bolt	BNHTZM8X25	20		20	40	20	40
M8x30 Zinc Plated 8.8 Bolt	BNHTZM8X30	20	20	20	40	20	40
M8x35 Zinc Plated 8.8 Bolt	BNHTZM8X35	20		20		20	40
M8x40 Zinc Plated 8.8 Bolt	BNHTZM8X40	20	20	20	40	20	40
M8x45 Zinc Plated 8.8 Bolt	BNHTZM8X45	20				20	40
M8x50 Zinc Plated 8.8 Bolt	BNHTZM8X50	20		20	40	20	40
M8x60 Zinc Plated 8.8 Bolt	BNHTZM8X60	20	20			20	40
M8x70 Zinc Plated 8.8 Bolt	BNHTZM8X70	20	20			20	40
M8x80 Zinc Plated 8.8 Bolt	BNHTZM8X80	20			40	20	40
M8x90 Zinc Plated 8.8 Bolt	BNHTZM8X90	20				20	40
M8x100 Zinc Plated 8.8 Bolt	BNHTZM8X100	20				20	40
M8x110 Zinc Plated 8.8 Bolt	BNHTZM8X110	20				20	40
M8x120 Zinc Plated 8.8 Bolt	BNHTZM8X120	20				20	40
M8x140 Zinc Plated 8.8 Bolt	BNHTZM8X140	20				20	40

Product Name	Code	BAG QTY	6-10MM 1,030pc KIT	6-12MM 1,420pc KIT	FARMERS 2,050pc KIT	WORKSHOP 3,154pc KIT	HEAVY WORKSHOP 5,568pc KIT
M10x20 Zinc Plated 8.8 Bolt	BNHTZM10X20	15	15		15	15	30
M10x25 Zinc Plated 8.8 Bolt	BNHTZM10X25	15	15	15	15	15	30
M10x30 Zinc Plated 8.8 Bolt	BNHTZM10X30	15	15		15	15	30
M10x35 Zinc Plated 8.8 Bolt	BNHTZM10X35	15		15		15	30
M10x40 Zinc Plated 8.8 Bolt	BNHTZM10X40	15	15		15	15	30
M10x45 Zinc Plated 8.8 Bolt	BNHTZM10X45	15				15	30
M10x50 Zinc Plated 8.8 Bolt	BNHTZM10X50	15	15	15	15	15	30
M10x60 Zinc Plated 8.8 Bolt	BNHTZM10X60	15				15	30
M10x70 Zinc Plated 8.8 Bolt	BNHTZM10X70	15	15			15	30
M10x80 Zinc Plated 8.8 Bolt	BNHTZM10X80	15			15	15	30
M10x90 Zinc Plated 8.8 Bolt	BNHTZM10X90	15				15	30
M10x100 Zinc Plated 8.8 Bolt	BNHTZM10X100	15				15	30
M10x110 Zinc Plated 8.8 Bolt	BNHTZM10X110	15				15	30
M10x120 Zinc Plated 8.8 Bolt	BNHTZM10X120	15				15	30
M10x130 Zinc Plated 8.8 Bolt	BNHTZM10X130	15				15	30
M10x140 Zinc Plated 8.8 Bolt	BNHTZM10X140	15				15	30
M10x150 Zinc Plated 8.8 Bolt	BNHTZM10X150	15				15	30
M10x160 Zinc Plated 8.8 Bolt	BNHTZM10X160	15				15	30

Product Name	Code	BAG QTY	6-10MM 1,030pc KIT	6-12MM 1,420pc KIT	FARMERS 2,050pc KIT	WORKSHOP 3,154pc KIT	HEAVY WORKSHOP 5,568pc KIT
M12x25 Zinc Plated 8.8 Bolt	BNHTZM12X25	10		10	20	10	20
M12x30 Zinc Plated 8.8 Bolt	BNHTZM12X30	10		10	20	10	20
M12x35 Zinc Plated 8.8 Bolt	BNHTZM12X35	10		10		10	20
M12x40 Zinc Plated 8.8 Bolt	BNHTZM12X40	10		10	20	10	20
M12x45 Zinc Plated 8.8 Bolt	BNHTZM12X45	10				10	20
M12x50 Zinc Plated 8.8 Bolt	BNHTZM12X50	10		10	20	10	20
M12x60 Zinc Plated 8.8 Bolt	BNHTZM12X60	10				10	20
M12x70 Zinc Plated 8.8 Bolt	BNHTZM12X70	10			10	10	20
M12x80 Zinc Plated 8.8 Bolt	BNHTZM12X80	10				10	20
M12x90 Zinc Plated 8.8 Bolt	BNHTZM12X90	10				10	20
M12x100 Zinc Plated 8.8 Bolt	BNHTZM12X100	10			10	10	20
M12x110 Zinc Plated 8.8 Bolt	BNHTZM12X110	10				10	20
M12x120 Zinc Plated 8.8 Bolt	BNHTZM12X120	10				10	20
M12x130 Zinc Plated 8.8 Bolt	BNHTZM12X130	10				10	20
M12x140 Zinc Plated 8.8 Bolt	BNHTZM12X140	10				10	20
M12x150 Zinc Plated 8.8 Bolt	BNHTZM12X150	10				10	20
M12x160 Zinc Plated 8.8 Bolt	BNHTZM12X160	10				10	20
M12x180 Zinc Plated 8.8 Bolt	BNHTZM12X180	10				10	20
M12x200 Zinc Plated 8.8 Bolt	BNHTZM12X200	10				10	20

Product Name	Code	BAG QTY	6-10MM 1,030pc KIT	6-12MM 1,420pc KIT	FARMERS 2,050pc KIT	WORKSHOP 3,154pc KIT	HEAVY WORKSHOP 5,568pc KIT
M14x30 Zinc Plated 8.8 Bolt	BNHTZM14X30	5				5	10
M14x35 Zinc Plated 8.8 Bolt	BNHTZM14X35	5				5	10
M14x40 Zinc Plated 8.8 Bolt	BNHTZM14X40	5				5	10
M14x45 Zinc Plated 8.8 Bolt	BNHTZM14X45	5				5	10
M14x50 Zinc Plated 8.8 Bolt	BNHTZM14X50	5				5	10
M14x60 Zinc Plated 8.8 Bolt	BNHTZM14X60	5				5	10
M14x90 Zinc Plated 8.8 Bolt	BNHTZM14X90	5				5	10
M14x100 Zinc Plated 8.8 Bolt	BNHTZM14X100	5				5	10

Farmers 2,050pc Bolt & Nut Kit



Product Name	Code	BAG QTY	6-10MM 1,030pc KIT	6-12MM 1,420pc KIT	FARMERS 2,050pc KIT	WORKSHOP 3,154pc KIT	HEAVY WORKSHOP 5,568pc KIT
M16x25 Zinc Plated 8.8 Bolt	BNHTZM16X25	6				6	12
M16x30 Zinc Plated 8.8 Bolt	BNHTZM16X30	6			12	6	12
M16x35 Zinc Plated 8.8 Bolt	BNHTZM16X35	6				6	12
M16x40 Zinc Plated 8.8 Bolt	BNHTZM16X40	6			12	6	12
M16x45 Zinc Plated 8.8 Bolt	BNHTZM16X45	6				6	12
M16x50 Zinc Plated 8.8 Bolt	BNHTZM16X50	6			12	6	12
M16x60 Zinc Plated 8.8 Bolt	BNHTZM16X60	6			12	6	12
M16x70 Zinc Plated 8.8 Bolt	BNHTZM16X70	6				6	12
M16x80 Zinc Plated 8.8 Bolt	BNHTZM16X80	6			12	6	12
M16x90 Zinc Plated 8.8 Bolt	BNHTZM16X90	6				6	12
M16x100 Zinc Plated 8.8 Bolt	BNHTZM16X100	6			6	6	12
M16x110 Zinc Plated 8.8 Bolt	BNHTZM16X110	4				6	12
M16x120 Zinc Plated 8.8 Bolt	BNHTZM16X120	4				6	12
M16x130 Zinc Plated 8.8 Bolt	BNHTZM16X130	4				6	12
M16x140 Zinc Plated 8.8 Bolt	BNHTZM16X140	4				6	12
M16x150 Zinc Plated 8.8 Bolt	BNHTZM16X150	4				6	12
M16x160 Zinc Plated 8.8 Bolt	BNHTZM16X160	4				6	12
M16x180 Zinc Plated 8.8 Bolt	BNHTZM16X180	4					



Zinc Plated Washers



Product Name	Code	BAG QTY	6-10MM 1,030pc KIT	6-12MM 1,420pc KIT	FARMERS 2,050pc KIT	WORKSHOP 3,154pc KIT	HEAVY WORKSHOP 5,568pc KIT
Washers M6X12X1.6	BNFWZPM6X12X1.6	100					
Washers M6X18X1.6	BNFWZPM6X18X1.6	100				100	200
Washers M6X22X2.0	BNFWZPM6X22X2.0	100	100	100	100	100	200
Penny Washers M6X32X1.6	BNFWZPM6X32X1.6	100					
Washers M8X16X1.6	BNFWZPM8X16X1.6	100				100	200
Heavy Washers M8X22X3	BNFWZPM8X22X3	100					
Washers M8X24X2	BNFWZPM8X24X2	100	100	100	100	100	200
Washers M8X28X3	BNFWZPM8X28X3	100				100	200
Penny Washers M8X32X1.6	BNFWZPM8X32X1.6	100					
Washers M10X20X2	BNFWZPM10X20X2	100			100	100	100
Washers M10X22X1.6	BNFWZPM10X22X1.6	100	100	100			
Washers M10X30X2.5	BNFWZPM10X30X2.5	100				100	100
Penny Washers M10X32X1.6	BNFWZPM10X32X1.6	100					
Washers M12X19X2.0	BNFWZPM12X19X2.0	50				50	50
Washers M12X25X2.5	BNFWZPM12X25X2.5	50		50	50	50	50
Heavy Washers M12X28X3	BNFWZPM12X28X3	50					
Washers M12X37X3	BNFWZPM12X37X3.0	50				50	50
Washers M14X28X2.5	BNFWZPM14X28X2.5	50				50	50
Washers M14X44X3	BNFWZPM14X44X3	50				50	50
Washers M16X30X3	BNFWZPM16X30X3	50			50	50	50
Washers M16X50X3	BNFWZPM16X50X3	50				50	50
Washers M20X37X3	BNFWZPM20X37X3	50			50	50	50
Washers M20X56X4	BNFWZPM20X56X4	50				50	50

Product Name	Code	BAG QTY	6-10MM 1,030pc KIT	6-12MM 1,420pc KIT	FARMERS 2,050pc KIT	WORKSHOP 3,154pc KIT	HEAVY WORKSHOP 5,568pc KIT
Spring Washers M6	BNSWZPM6	100	100	200	100	100	200
Spring Washers M8	BNSWZPM8	100	100	200	100	100	200
Spring Washers M10	BNSWZPM10	50	50	50	50	50	100
Spring Washers M12	BNSWZPM12	50		50	50	50	100
Spring Washers M14	BNSWZPM14	25				25	50
Spring Washers M16	BNSWZPM16	25			25	25	50
Spring Washers M20	BNSWZPM20	25			25	25	50

Product Name	Code	BAG QTY	6-10MM 1,030pc KIT	6-12MM 1,420pc KIT	FARMERS 2,050pc KIT	WORKSHOP 3,154pc KIT	HEAVY WORKSHOP 5,568pc KIT
M20x40 Zinc Plated 8.8 Bolt	BNHTZM20X40	6			6	6	12
M20x45 Zinc Plated 8.8 Bolt	BNHTZM20X45	6				6	12
M20x50 Zinc Plated 8.8 Bolt	BNHTZM20X50	6				6	12
M20x60 Zinc Plated 8.8 Bolt	BNHTZM20X60	6				6	12
M20x70 Zinc Plated 8.8 Bolt	BNHTZM20X70	6				6	12
M20x80 Zinc Plated 8.8 Bolt	BNHTZM20X80	6				6	12
M20x90 Zinc Plated 8.8 Bolt	BNHTZM20X90	6				6	12
M20x100 Zinc Plated 8.8 Bolt	BNHTZM20X100	6				6	12
M20x110 Zinc Plated 8.8 Bolt	BNHTZM20X110	4				4	8
M20x120 Zinc Plated 8.8 Bolt	BNHTZM20X120	4			4	4	8
M20x130 Zinc Plated 8.8 Bolt	BNHTZM20X130	4				4	8
M20x140 Zinc Plated 8.8 Bolt	BNHTZM20X140	4				4	8
M20x150 Zinc Plated 8.8 Bolt	BNHTZM20X150	4				4	8
M20x160 Zinc Plated 8.8 Bolt	BNHTZM20X160	4				4	8
M20x180 Zinc Plated 8.8 Bolt	BNHTZM20X180	4					
M20x200 Zinc Plated 8.8 Bolt	BNHTZM20X200	4					

M6 - M12 1,040pc Kit



Zinc Plated Nuts

Product Name	Code	BAG QTY	6-10MM 1,030pc KIT	6-12MM 1,420pc KIT	FARMERS 2,050pc KIT	WORKSHOP 3,154pc KIT	HEAVY WORKSHOP 5,568pc KIT
M6x1.0p Zinc Nyloc Nut	BNNMCZPM6	50	50	100	50	50	50
M8x1.25p Zinc Nyloc Nut	BNNMCZPM8	50	50	100	50	50	50
M10x1.5p Zinc Nyloc Nut	BNNMCZPM10	50	50	50	50	20	50
M12x1.75p Zinc Nyloc Nut	BNNMCZPM12	25		25	50	25	50
M14x2.0P Zinc Nyloc Nut	BNNMCZPM14	25				25	50
M16x2.0P Zinc Nyloc Nut	BNNMCZPM16	20			20	20	40
M20x2.5P Zinc Nyloc Nut	BNNMCZPM20	20			20	20	40

Product Name	Code	BAG QTY	6-10MM 1,030pc KIT	6-12MM 1,420pc KIT	FARMERS 2,050pc KIT	WORKSHOP 3,154pc KIT	HEAVY WORKSHOP 5,568pc KIT
M6x1.0p Zinc Nut	BNHMCZPM6	25			50	25	50
M8x1.25 Zinc Nut	BNHMCZPM8	25			50	25	50
M10x1.5p Zinc Nut	BNHMCZPM10	25			50	25	50
M12x1.75p Zinc Nut	BNHMCZPM12	25			50	25	50
M14x2.0P Zinc Nut	BNHMCZPM14	25				25	50
M16x2.0P Zinc Nut	BNHMCZPM16	20			20	20	40
M20x2.5P Zinc Nut	BNHMCZPM20	20			20	20	40

Stainless Steel & Threaded Rod

316 Stainless Steel Bolts

Product Name	Code
M5X20 S/S 316 Bolt (Full Thread)	BNHSS316MC5X20
M5X25 S/S 316 Bolt (Full Thread)	BNHSS316MC5X25
M5X30 S/S 316 Bolt (Full Thread)	BNHSS316MC5X30
M5X40 S/S 316 Bolt (Full Thread)	BNHSS316MC5X40
M5X50 S/S 316 Bolt (Full Thread)	BNHSS316MC5X50
M6x20 S/S 316 Bolt (Full Thread)	BNHSS316MC6X20
M6X25 S/S 316 Bolt (Full Thread)	BNHSS316MC6X25
M6x30 S/S 316 Bolt (Full Thread)	BNHSS316MC6X30
M6X40 S/S 316 Bolt (Full Thread)	BNHSS316MC6X40
M6X50 S/S 316 Bolt (Full Thread)	BNHSS316MC6X50
M8X20 S/S 316 Bolt (Full Thread)	BNHSS316MC8X20
M8x25 S/S 316 Bolt (Full Thread)	BNHSS316MC8X25
M8x30 S/S 316 Bolt (Full Thread)	BNHSS316MC8X30
M8X40 S/S 316 Bolt (Full Thread)	BNHSS316MC8X40
M8X50 S/S 316 Bolt (Full Thread)	BNHSS316MC8X50
M10X25 S/S 316 Bolt (Full Thread)	BNHSS316MC10X25
M10X30 S/S 316 Bolt (Full Thread)	BNHSS316MC10X30
M10X40 S/S 316 Bolt (Full Thread)	BNHSS316MC10X40
M10X50 S/S 316 Bolt (Full Thread)	BNHSS316MC10X50
M10X60 S/S 316 Bolt (Full Thread)	BNHSS316MC10X60
M12X25 S/S 316 Bolt (Full Thread)	BNHSS316MC12X25
M12X30 S/S 316 Bolt (Full Thread)	BNHSS316MC12X30
M12X40 S/S 316 Bolt (Full Thread)	BNHSS316MC12X40
M12X50 S/S 316 Bolt (Full Thread)	BNHSS316MC12X50
M12X60 S/S 316 Bolt (Full Thread)	BNHSS316MC12X60
M12X80 S/S 316 Bolt (Full Thread)	BNHSS316MC12X80

316 Stainless Washers

Product Name	Code
Flat Washer M5 x 12.5 x 1	BNFWSS316M5X12.5X1
Flat Washer M5 x 12.5 x 1	BNFWSS316M5.3X15X1
Flat Washer M6 x 12 x 1.6	BNFWSS316M6X12X1.6
Flat Washer M6.4 x 32 x 1.6	BNFWSS316M6.4X32X1.6
Flat Washer M8 x 16 x 1.6	BNFWSS316M8X16X1.6
Flat Washer M8.4 x 32 x 2	BNFWSS316M8.4X32X2
Flat Washer M10 x 20 x 2	BNFWSS316M10X20X2
Flat Washer M10.5 x 32 x 2.5	BNFWSS316M10.5X32X2.5
Flat Washer M12 x 24 x 1.5	BNFWSS316M12X24X1.5
Flat Washer M12 x 32 x 1.5	BNFWSS316M12X32X1.5

316 Stainless Spring Washers

Product Name	Code
M5 Spring Washers S/S 316	BNSWSS316M5
M6 Spring Washers S/S 316	BNSWSS316M6
M8 Spring Washers S/S 316	BNSWSS316M8
M10 Spring Washers S/S 316	BNSWSS316M10
M12 Spring Washers S/S 316	BNSWSS316M12

316 Stainless Nyloc Nuts

Product Name	Code
M5 Nyloc Nut S/S 316	BNNNSS316MC5
M6 Nyloc Nut S/S 316	BNNNSS316MC6
M8 Nyloc Nut S/S 316	BNNNSS316MC8
M10 Nyloc Nut S/S 316	BNNNSS316MC10
M12 Nyloc Nut S/S 316	BNNNSS316MC12

316 Stainless Standard Nuts

Product Name	Code
M5 NUT S/S 316	BNHNSS316MC5
M6 NUT S/S 316	BNHNSS316MC6
M8 NUT S/S 316	BNHNSS316MC8
M10 NUT S/S 316	BNHNSS316MC10
M12 NUT S/S 316	BNHNSS316MC12



Threaded Rod 1M Lengths

Product Name	Code
Threaded Rod S/S 316 M4	BNTRSS316MC4
Threaded Rod S/S 316 M5	BNTRSS316MC5
Threaded Rod S/S 316 M6	BNTRSS316MC6
Threaded Rod S/S 316 M8	BNTRSS316MC8
Threaded Rod S/S 316 M10	BNTRSS316MC10
Threaded Rod S/S 316 M12	BNTRSS316MC12
Threaded Rod S/S 316 M16	BNTRSS316MC16
Threaded Rod S/S 316 M20	BNTRSS316MC20

Product Name	Code
Threaded Rod Zinc 4.8 M4	BNTRZPMC4
Threaded Rod Zinc 4.8 M5	BNTRZPMC5
Threaded Rod Zinc 4.8 M6	BNTRZPMC6
Threaded Rod Zinc 4.8 M8	BNTRZPMC8
Threaded Rod Zinc 4.8 M10	BNTRZPMC10
Threaded Rod Zinc 4.8 M12	BNTRZPMC12
Threaded Rod Zinc 4.8 M16	BNTRZPMC16
Threaded Rod Zinc 4.8 M20	BNTRZPMC20



Cleaning & Tape



Industrial Hand Cleaner

Fire Bird heavy duty hand cleaner with a fresh lime fragrance .
All natural walnut micro beads.
For grease, grime Tar paint many other soils.

Part Number	Description
CHFBHCM4-4L	HAND CLEANER 4L DISPENSER PODS
CHFBHCM-5L	HEAVY DUTY NATURAL HAND CLEANER 5L
CHFBHCM-18KG	HEAVY DUTY NATURAL HAND CLEANER 18KG

Industrial Degreaser

Fire Bird industrial degreaser removes Grime, oil, Diesel, Grease, fat, carbon, cooking oils, Dirt, grass stains.
So many different uses, designed to be sprayed on, most surfaces
use with care: diluted with water.

Part Number	Description
CHFBHD-5L	EXTRA HEAVY DUTY DEGREASER 5L
CHFBHD-20L	EXTRA HEAVY DUTY DEGREASER 20L



Cloth Tape

Part Number	Description	Sold Each	Carton
TACTFB48X30BLACK	Black 48mm x 30M x 0.25mm	Yes	48
TACTFB48X30BLU	Blue 48mm x 30M x 0.25mm	Yes	48
TACTFB48X30GRN	Green 48mm x 30M x 0.25mm	Yes	48
TACTFB48X30GRY	Grey 48mm x 30M x 0.25mm	Yes	48
TACTFB48X30RED	Red 48mm x 30M x 0.25mm	Yes	48
TACTFB48X30WHT	White 48mm x 30M x 0.25mm	Yes	48
TACTFB48X30YEL	Yellow 48mm x 30M x 0.25mm	Yes	48

Insulation tape

Part Number	Description	Sold Each	Wrap
TAITFB19X20BLK	Black 19mm x 20M x 0.13mm	Yes	10
TAITFB19X20BLU	Blue 19mm x 20M x 0.13mm	Yes	10
TAITFB19X20GRN	Green 19mm x 20M x 0.13mm	Yes	10
TAITFB19X20RED	Red 19mm x 20M x 0.13mm	Yes	10
TAITFB19X20WHT	White 19mm x 20M x 0.13mm	Yes	10
TAITFB19X20YEL	Yellow 19mm x 20M x 0.13mm	Yes	10



Compressed Workshop Rags

Part Number	Description	Sold Each	Pallet Size
MPFBRAGS-MIX2.5KG	Mixed Cotton Compressed 2.5kg	Yes	
MPFBRAGS-MIX10KG	Mixed Cotton Compressed 10kg	Yes	45
MPFBRAGS-MIX16KG	Mixed Cotton bag 16kg	Yes	45
MPFBRAGS-WH10KG	White Cotton Compressed 10kg	Yes	45
MPFBRAGS-TWL5KG	White Toweling Compressed 5kg	Yes	45

Paint Rollers

GRIZZLYPRO



Ultra Glide Lite Roller Frames

GrizzlyPRO ultra glide-lite aluminium frames makes for 30% lighter use, reducing fatigue and increasing productivity.

Ultra glide-lite double-bearing roller system comprises 6 wire cages (on 230mm and 270mm models) for superior smooth gliding.

We also have the mini version for the 110mm mini-rollers and the adjustable version for size 250mm to 400mm.

Professionals simply need to slide their desired paint rollers into the arms, and for the extendable version, secure the wingnut grip, and they are away!

With a universal threaded handle based on all models, professionals can simply install a GrizzlyPRO extended pole for greater control over your work area.

Product Name	Code
Roller frame 110mm	GZ-RF110
Roller frame 230mm	GZ-RF230MM
Roller frame 270mm	GZ-RF270
Roller frame adjustable 250mm-400mm	GZ-RFADJ250-400



Microfibre Paint Roller Sleeves



Microfibre rollers are suitable for water-based and oil-based paints; they are at best for light to medium-textured surfaces, resulting in the smoothest finish and the thickest coverage. With this soft, porous material, paint is evenly and densely coated over the surfaces.

A 6MM nap roller will produce the smoothest finish as the shorter nap generates fewer bubbles. It is best suited for gloss and semi-gloss paints. Ideal for use on walls, ceilings, cabinetry, wood, and other surfaces without texture, including metal.

A 10MM nap roller is best suited for light to medium textured surfaces and produces seamless results. Ideal for use on ceilings, drywall, and lightly textured surfaces, including most interior walls.

A 15MM nap roller is a good length for moderately textured walls, paneling and painted brick or concrete. Professionals prefer a much thicker nap (or length of fabric) as it is able to hold more paint, meaning fewer trips to the paint tray and a wetter edge for seamless results.

Product Name	Code	Carton Size
1PC OF 10 110mm Microfiber sleeves 10mm nap	GZ-REDLABEL11010-1	48
1PC OF 10 110mm Microfiber sleeves 6mm nap	GZ-REDLABEL11006-1	48
1PC 270mm Microfiber sleeves 10mm nap	GZ-REDLABEL27010-1	48
1PC 230mm Microfiber sleeves 10mm nap	GZ-REDLABEL23010-1	48
1PC 270mm Microfiber sleeves 15mm nap	GZ-REDLABEL 27015-1	48
1PC 270mm Microfiber sleeves 6mm nap	GZ-REDLABEL 27006-1	48
1PC 360mm Microfiber sleeves 10mm nap	GZ-REDLABEL36010-1	48
1PC 360mm Microfiber sleeves 15mm nap	GZ-REDLABEL36015-1	48

Ultra Premium Draylon Rollers

Draylon is a synthetic and lint-free fabric, providing a smooth and even finish; best suited for water-based and oil-based paints.

A draylon 10mm nap roller is best suited for medium-textured surfaces.

With a 270mm width, this offers optimum balance between coverage and maneuverability.

Product Name	Code	Carton Size
1PC 270mm Draylon sleeves 10mm nap	GZ-BLUELABEL27010-1	48



Industrial Paint Roller Extendable Poles

GrizzlyPRO extendable painters' poles are durable, lightweight but strong without compromising on grip and comfort.

Professionals can easily extend or retract the pole to their desired reach. With increments each of 100mm, set the pole to the desired length, once selected it instantly locks securely into place to avoid twisting or loosening during use.

GrizzlyPRO extension poles offer greater stability and smoother rolling application, to give superior results at a realistic price point.

Every pole comes with two bonus universal threads for use with all standard roller frames (with one thread secured at the base of the pole) and another one on the tip of the pole.

Product Name	Code
Extendable Pole 0.3M-0.6M	GZ-POLE1
Extendable Pole 0.6M-1.2M	GZ-POLE2



Tig Consumables

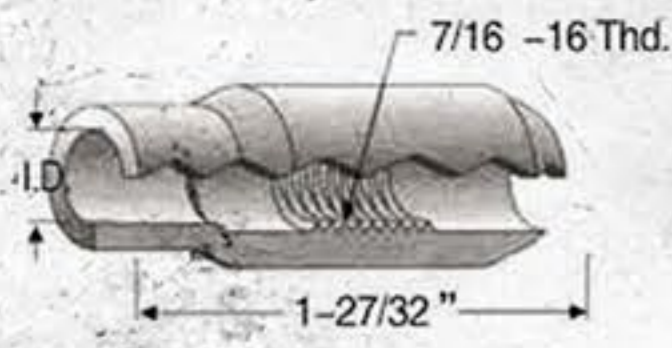

Alumina 1-27/32"

PART NO.	I.D.	SIZE
WETC 10N50-2PK	1/4"	4
WETC 10N49-2PK	5/16"	5
WETC 10N48-2PK	3/8"	6
WETC 10N47-2PK	7/16"	7
WETC 10N46-2PK	1/2"	8
WETC 10N45-2PK	5/8"	10
WETC 10N44-2PK	3/4"	12

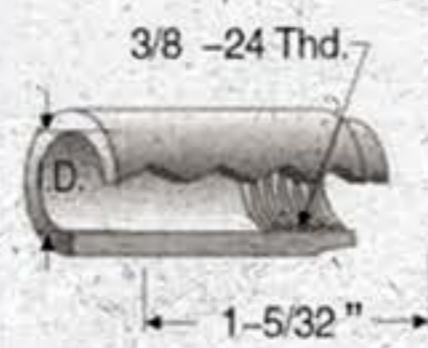

Alumina 1-5/32"

PART NO.	I.D.	SIZE
WETC 13N08-2PK	1/4"	4
WETC 13N09-2PK	5/16"	5
WETC 13N10-2PK	3/8"	6
WETC 13N11-2PK	7/16"	7
WETC 13N12-2PK	1/2"	8
WETC 13N13-2PK	5/8"	10

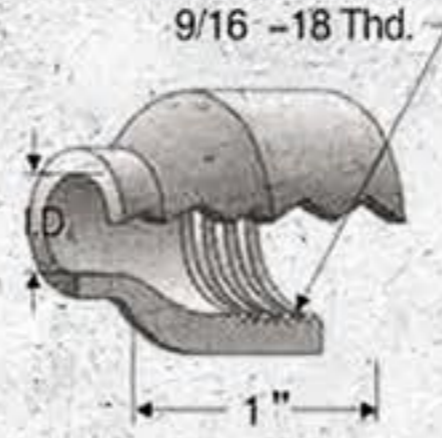

Alumina for Gas Lens 1"

PART NO.	I.D.	SIZE
WETC 53N58-2PK	1/4"	4
WETC 53N59-2PK	5/16"	5
WETC 53N60-2PK	3/8"	6
WETC 53N61-2PK	7/16"	7

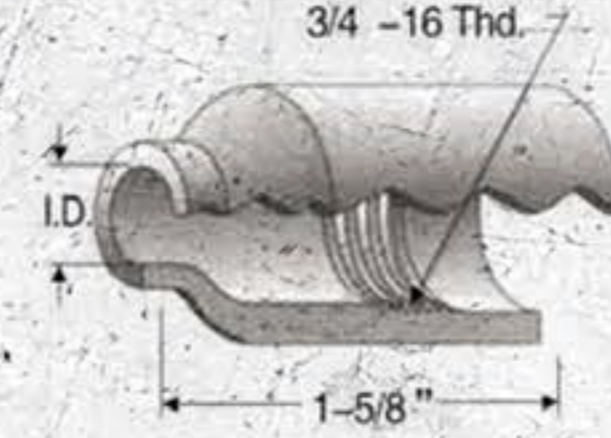

Alumina for Gas Lens 1-5/8"

PART NO.	I.D.	SIZE
WETC 54N18-2PK	1/4"	4
WETC 54N17-2PK	5/16"	5
WETC 54N16-2PK	3/8"	6
WETC 54N15-2PK	7/16"	7
WETC 54N14-2PK	1/2"	8
WETC 54N19-2PK	11/16"	short

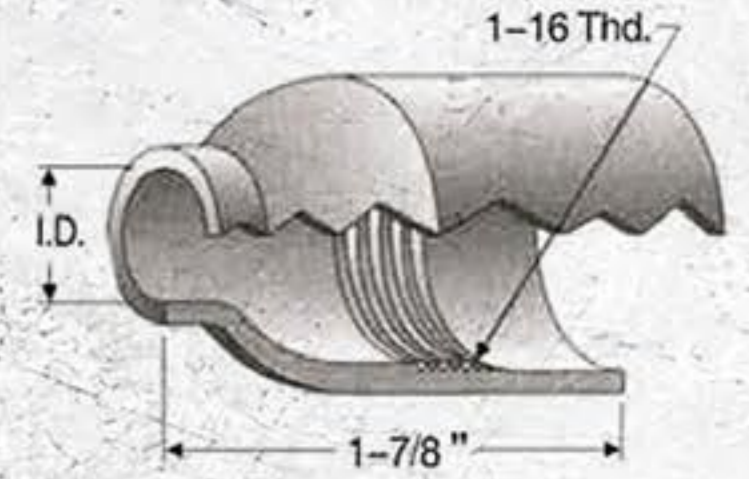

Alumina for X-LG. Gas Lens 1-7/8"

PART NO.	I.D.	SIZE
WETC 57N75-2PK	3/8"	6
WETC 57N74-2PK	1/2"	8
WETC 53N88-2PK	5/8"	10
WETC 53N87-2PK	3/4"	12
WETC 53N89-2PK		short

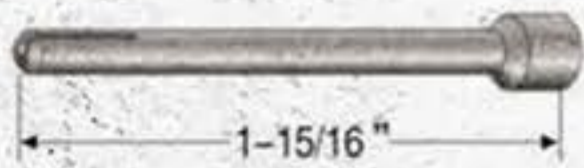

Collet

PART NO.	TUNGSTEN
WETC 10N24-2PK	3/32"
WETC 10N25-2PK	1/8"
WETC 10N20-2PK	5/32"



Collet

PART NO.	TUNGSTEN
WETC 13N22-2PK	1/16"
WETC 13N23-2PK	3/32"
WETC 13N24-2PK	1/8"



Collet

PART NO.	TUNGSTEN
WETC 53N14-2PK	1/16"
WETC 24C332-2PK	3/32"



Collet for gas lens

PART NO.	TUNGSTEN
WETC 53N64-2PK	1/16"
WETC 24GLC332-2I	3/32"

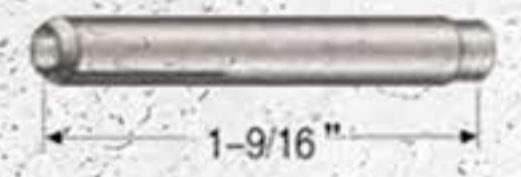

Collet for extra large gas lens

PART NO.	TUNGSTEN
WETC 13N22L-2PK	1/16"
WETC 13N23L-2PK	3/32"
WETC 13N24L-2PK	1/8"



Collet for 27 torches

PART NO.	TUNGSTEN
WETC 57N46-2PK	1/16"
WETC 57N47-2PK	3/32"
WETC 57N48-2PK	1/8"



Back caps

PART NO.	TUNGSTEN
WETBC41Y24-2pk	Long back cap
WETBC41Y35-2pk	Med. Back cap
WETBC41Y33-2pk	Short back cap

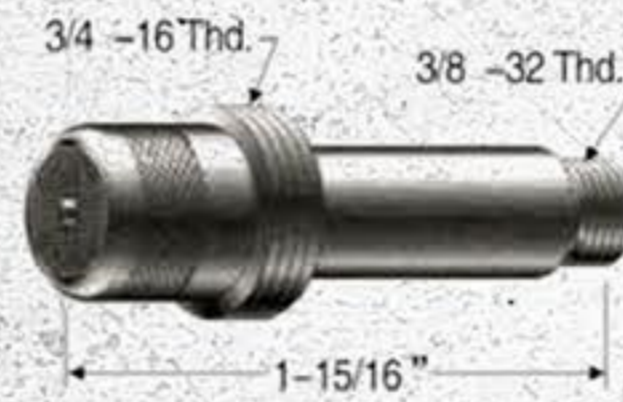

Gas lens

PART NO.	TUNGSTEN
WETGL45V25-2pk	1/16"
WETGL45V26-2pk	3/32"
WETGL45V27-2pk	1/8"



Extra large gas lens

PART NO.	TUNGSTEN
WETGL45V64-2pk	3/32"
WETGL995795-2pk	1/8"

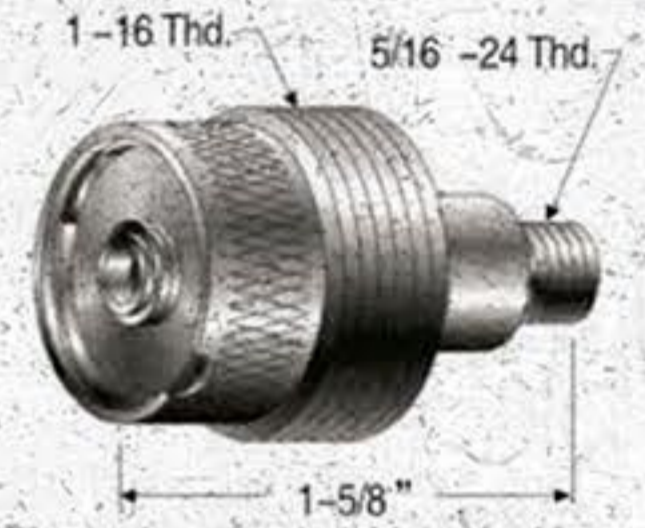

Extra large stubby gas lens

PART NO.	TUNGSTEN
WETGL45V64S-2pk	1/16" .040, .020
WETGL45V116S-2pk	3/32"

Tungsten Electrodes

Product Name	Code
TUNGSTENS THORIATED 1.6mm	WETTT1.6MM
TUNGSTENS THORIATED 2.4mm	WETTT2.4MM
TUNGSTENS THORIATED 3.2mm	WETTT3.2MM
TUNGSTENS ZIRCONIATED 1.6mm	WETTZ1.6MM
TUNGSTENS ZIRCONIATED 2.4mm	WETTZ2.4MM
TUNGSTENS ZIRCONIATED 3.2mm	WETTZ3.2MM

Tig Torch Head

Product Name	Code
17 TIG TORCH HEAD	WETTH17
17F TIG TORCH HEAD	WETTH17F
18 TIG TORCH HEAD	WETTH18
18F TIG TORCH HEAD	WETTH18F
26 TIG TORCH HEAD	WETTH26
26F TIG TORCH HEAD	WETTH26F

Complete Tig Torch

Product Name	Code
WP17 TIG TORCH 3.8M	WETWP17F-3.8M
WP18 TIG TORCH 3.8M	WETWP18-3.8M
WP26V TIG TORCH 3.8M	WETWP26V-3.8M



Tungsten Electrodes

2.4mm x 175mm

[approx. 3/32" x 7"]
2% Thoriated (WT20)

10 Pieces

Ground Finish

ANSI/AWS A5.12M-98
ISO 6848

Mig Welding Wire



HYUNDAI WELDING

Solid Welding Wire



Supercored 71 Flux Cored Welding Wire



Part Number	Description	Sold Each	Pallet Size
WEHMW71H1.2-15KG	1.2mm Mig Wire 71H 15kg flux cored	Yes	72
WEHMW71H1.6-15KG	1.6mm Mig Wire 71H 15kg flux cored	Yes	72
WEHMW71T1.2-15KG	1.2mm Mig Wire 71T 15kg flux cored	Yes	72
WEHMWGW0.9-5KG	0.9mm Gasless Mig Wire 5kg	Yes	72
WEHMWGW1.2-5KG	1.2mm Gasless Mig Wire 5kg	Yes	72
WEHMWMS0.8-5KG	0.8mm Mig Wire mild steel 5kg	Yes	72
WEHMWMS0.9-5KG	0.9mm Mig Wire mild steel 5kg	Yes	72
WEHMWMS1.0-5KG	1.0mm Mig Wire mild steel 5kg	Yes	72
WEHMWMS1.2-5KG	1.2mm Mig Wire mild steel 5kg	Yes	72
WEHMWMS0.8-15KG	0.8mm Mig Wire mild steel 15kg	Yes	72
WEHMWMS0.9-15KG	0.9mm Mig Wire mild steel 15kg	Yes	72
WEHMWMS1.0-15KG	1.0mm Mig Wire mild steel 15kg	Yes	72
WEHMWMS1.2-15KG	1.2mm Mig Wire mild steel 15kg	Yes	72



Mig Gun Consumables



Tweco Style 32 Insulator

Product Name	Code	Pack Qty
INSULATOR 32	WEMGIT32	5



Tweco Style 52 Defuser

Product Name	Code	Pack Qty
GAS DIFFUSER 52	WEMGDT52	5



Tweco Style A Nozzle

Product Name	Code	Pack Qty
1/2" NOZZLE 24A50	WEMNT24A50	2
5/8" NOZZLE 24A62	WEMNT24A62	2
3/4" NOZZLE 24A75	WEMNT24A75	2



Tweco Style 34A Insulator

Product Name	Code	Pack Qty
INSULATOR 34A	WEMGIT34A	5



Tweco Style 54A Defuser

Product Name	Code	Pack Qty
GAS DIFFUSER 54A	WEMGDT54A	5

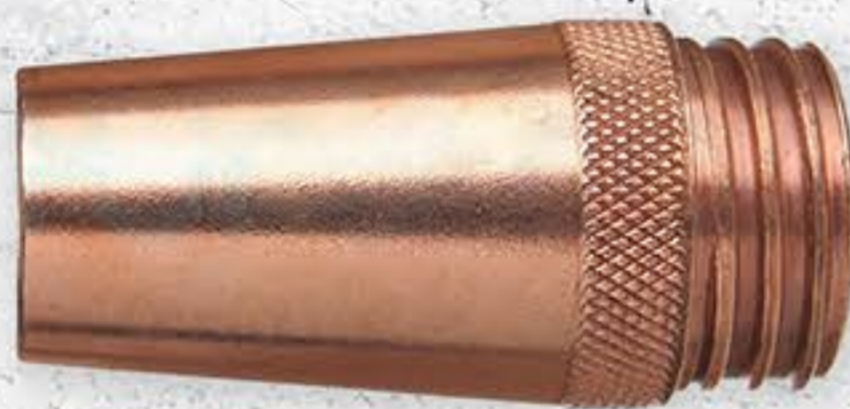

Tweco Style CT Nozzle

Product Name	Code	Pack Qty
1/2" NOZZLE 24CT50	WEMNT24CT50	2
5/8" NOZZLE 24CT62	WEMNT24CT62	2
3/4" NOZZLE 24CT75	WEMNT24CT75	2



Tweco Style 34CT Insulator

Product Name	Code	Pack Qty
INSULATOR 34CT	WEMGIT34CT	5



Tweco Style Contact Tips

Product Name	Code	Pack Qty
CONTACT TIP 0.8x1/4	WEMCTT14-30	10
CONTACT TIP 0.9x1/4	WEMCTT14-35	10
CONTACT TIP 1.0x1/4	WEMCTT14-40	10
CONTACT TIP 1.2x1/4	WEMCTT14-45	10
CONTACT TIP 1.6x1/4	WEMCTT14-116	10



Earth Clamps

Product Name	Code
EARTH CLAMP 200A	WEEC-200A
EARTH CLAMP 300A	WEEC-300A
EARTH CLAMP 400A	WEEC-400A
EARTH CLAMP 500A	WEEC-500A



Cable Connectors

Product Name	Code
Female Connector 10-25mm ²	WEWCF10-25MM2
Female Connector 30-50mm ²	WEWCF30-50MM2
Female Connector 50-70mm ²	WEWCF50-70MM2
Female Connector 70-95mm ²	WEWCF70-95MM2
Male-Male Connector 50-70mm ²	WEWCM50-70MM2
Male Connector 10-25mm ²	WEWCM10-25MM2
Male Connector 30-50mm ²	WEWCM30-50MM2
Male Connector 50-70mm ²	WEWCM50-70MM2
Male Connector 70-95mm ²	WEWCM70-95MM2

Mig Gun Consumables



**Binzel Style 24
Conical Nozzle**

Product Name	Code	Pack Qty
12.5mm NOZZLE MB24KD	WEMN24-12.5	2



**Binzel Style 24/25
Contact Tip M6x8**

Product Name	Code	Pack Qty
M6x8x28x0.8mm TIP	WEMCTM6X0.8	10
M6x8x28x0.9mm TIP	WEMCTM6X0.9	10
M6x8x28x1.0mm TIP	WEMCTM6X1.0	10
M6x8x28x1.2mm TIP	WEMCTM6X1.2	10



**Binzel Style 25
Conical Nozzle**

Product Name	Code	Pack Qty
14mm NOZZLE MB25KD	WEMN25-14	2



**Binzel Style 36
Conical Nozzle**

Product Name	Code	Pack Qty
16mm NOZZLE MB36KD	WEMN36-16	2



**Binzel Style 35/501
Contact Tip M8x10**

Product Name	Code	Pack Qty
M8x0.8mm TIP	WEMCTM8X0.8	10
M8x0.9mm TIP	WEMCTM8X0.9	10
M8x1.0mm TIP	WEMCTM8X1.0	10
M8x1.2mm TIP	WEMCTM8X1.2	10
M8x1.2mm ALUM TIP	WEMCTM8X1.2A	10
M8x1.4mm TIP	WEMCTM8X1.4	10
M8x1.6mm TIP	WEMCTM8X1.6	10



**Binzel Style 501
Nozzles**

Product Name	Code	Pack Qty
16mm NOZZLE MB501KD	WEMN50-16	2



**Binzel Style 24
Tip Holder M6**

Product Name	Code	Pack Qty
TIP HOLDER M6 MB24	WEMCTHM6X28	5



**Binzel Style 24
Diffuser White Ceramic**

Product Name	Code	Pack Qty
DIFFUSER MB24KD	WEMGDMB24	5



**Binzel Style 25
Tip Holder/Defuser M6**

Product Name	Code	Pack Qty
TIP HOLDER M6 MB25	WEMCTHM6X25	5



**Binzel Style 36
Diffuser White Ceramic**

Product Name	Code	Pack Qty
DIFFUSER MB36KD	WEMGDMB36	5



**Binzel Style 36
Tip Holder M8 or M6**

Product Name	Code	Pack Qty
TIP HOLDER M8 MB36KD	WEMCTHM8X28	5



**Binzel Style 501
Diffuser White Ceramic**

Product Name	Code	Pack Qty
DIFFUSER MB501KD	WEMGDMB510	5



**Binzel Style 501
Tip Holder M8**

Product Name	Code	Pack Qty
TIP HOLDER M8 MB501KD	WEMCTHM8X29	5

Mig Torches

Product Name	Code
MB24KD 3M BINZLE TYPE	WEMMB24KD-3M
MB36KD 5M BINZLE TYPE	WEMMB36KD-5M
MB501D 5M BINZLE TYPE	WEMMB50KD-5M





FIREBIRD

INDUSTRIAL CONSUMABLES

GRIZZLYPRO



HYUNDAI
W E L D I N G

IWL INDUSTRIAL
WHOLESALE
LIMITED

firebirdnz.co.nz