

WTA



Installation Guide

Sprinter Stealth Roof Rack 170

Ensuring the proper assembly and secure attachment of all WTA products to your vehicle is of utmost importance. Failure to adhere to these guidelines may lead to automobile accidents, presenting a substantial risk of bodily harm or even fatality to yourself and others. As the owner, it is incumbent upon you to meticulously assemble and secure WTA products, conducting a thorough examination of the mounting points and attachments before use, and routinely checking for any indications of wear or damage.

To ensure optimal safety, we strongly recommend enlisting the services of a qualified installer for the installation of any aftermarket accessories on your vehicle. If you lack mechanical expertise or are unfamiliar with the installation procedures, it is crucial to have the product installed by a certified professional or individuals with the requisite skills. Remember, the responsibility rests with you, and it must be approached with seriousness to safeguard the well-being of all individuals involved.

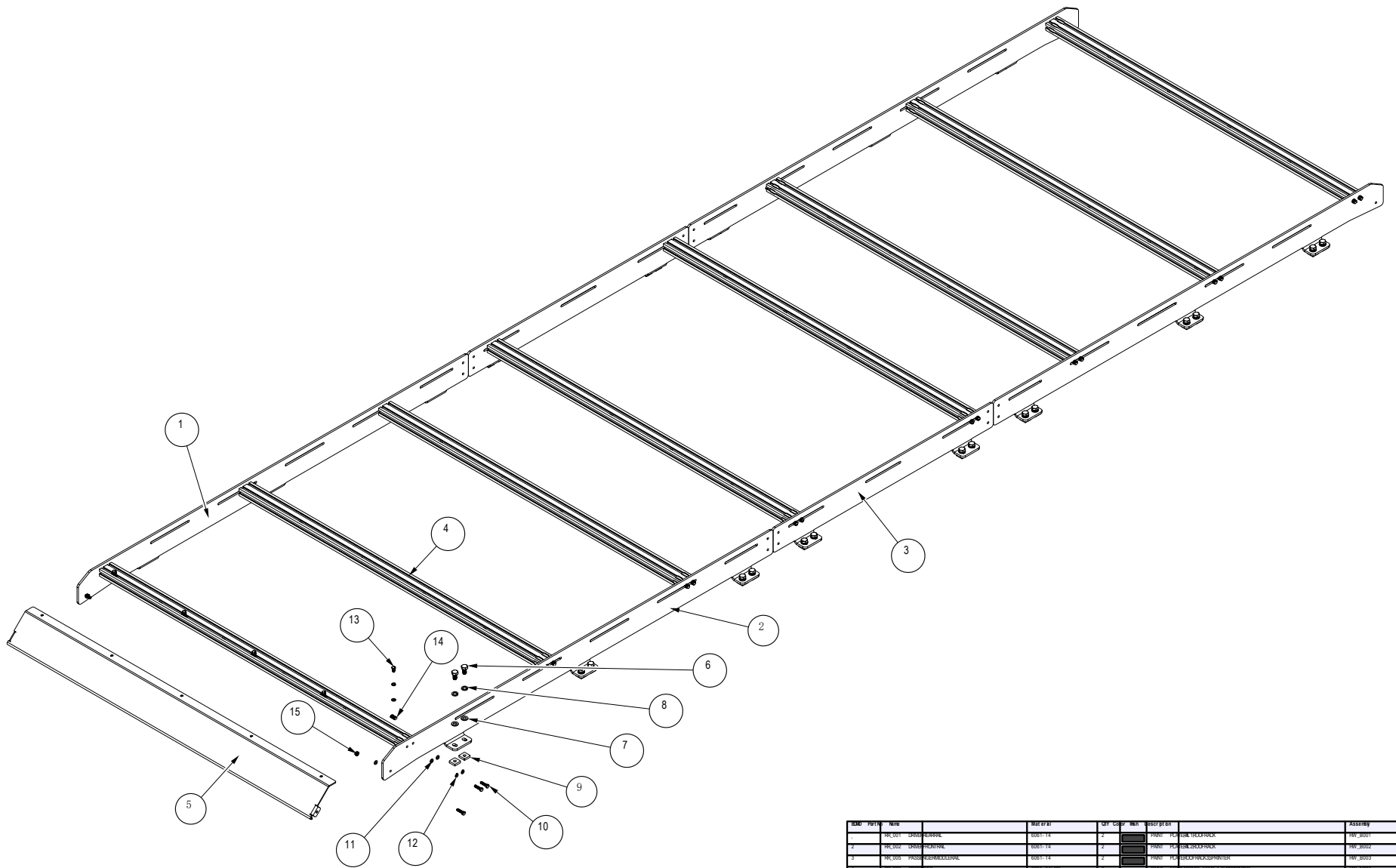

ITEM	Part No	Desc	MAT OR	QTY	UNIT	GROUP	ASSEMBLY
1	RC001	FRAME RENEW	8003-T4	2		FRAM	RC001
2	RC002	FRAME RENEW	8003-T4	2		FRAM	RC002
3	RC003	FRAME RENEW	8003-T4	2		FRAM	RC003
4	RC004	ROLLER	8003-T4-00	8		FRAM	RC004
5	RC005	ROLLER	8003-T4	1		FRAM	RC005
6	WV_B01	BLANK	16-BRASS/SS/AL	1		WASER	WV_B01
7	WV_W01	WASHER	AB04	32		WASER	WV_W01
8	WV_W02	WASHER	AB04	32		WASER	WV_W02
9	WV_W03	WASHER	AB04	24		WASER	WV_W03
10	WV_W04	WASHER	AB04	24		WASER	WV_W04
11	WV_W05	WASHER	AB04	43		WASER	WV_W05
12	WV_W06	WASHER	AB04	41		WASER	WV_W06
13	WV_W07	WASHER	AB04	7		WASER	WV_W07
14	WV_W08	WASHER	AB04	7		WASER	WV_W08
15	WV_W09	WASHER	AB04	2		WASER	WV_W09
16	WV_W10	WASHER	AB04	2		WASER	WV_W10

THANK YOU!

- PLEASE INSPECT THE PRODUCT TO ENSURE THERE WAS NO DAMAGE INCURRED DURING SHIPPING.
- IF THERE IS DAMAGE TO REPORT, PLEASE CONTACT OUR CUSTOMER SERVICE DEPARTMENT AS SOON AS POSSIBLE.
- NEXT, USING THE “PACKAGE CONTENTS” PAGE, CHECK INVENTORY AND FAMILIARIZE YOURSELF WITH THE PARTS AND HARDWARE.
- GATHER ALL TOOLS REQUIRED FOR INSTALL.
 - 10 mm WRENCH
 - 17 mm WRENCH

TOOLS

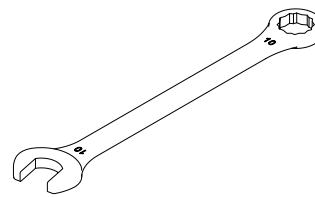

10 mm Wrench

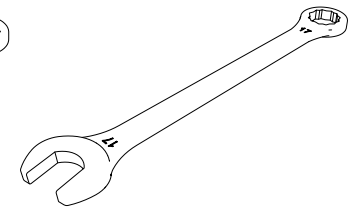

17 mm Wrench

PACKAGE CONTENTS

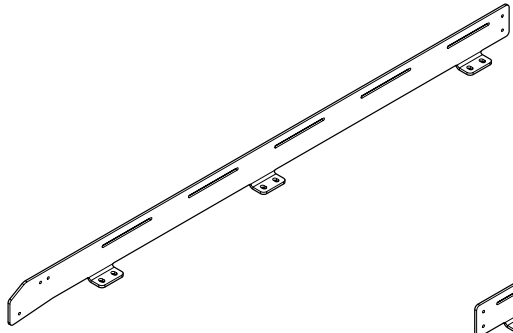

DRIVER FRONT RAIL
QTY-1

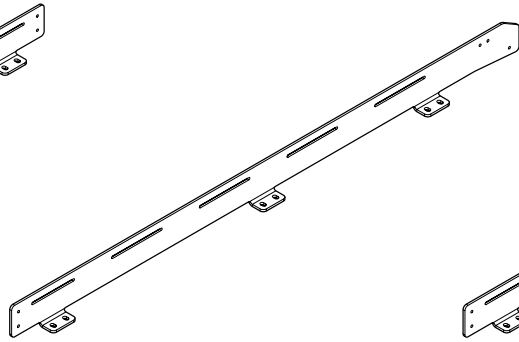

DRIVER REAR RAIL
QTY-1

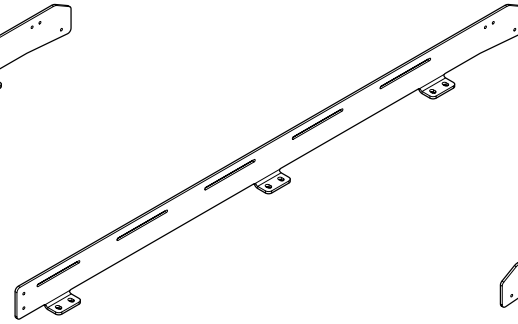

PASSENGER FRONT RAIL
QTY-1

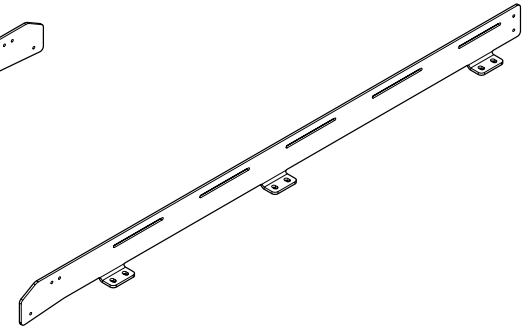

PASSENGER REAR RAIL
QTY-1

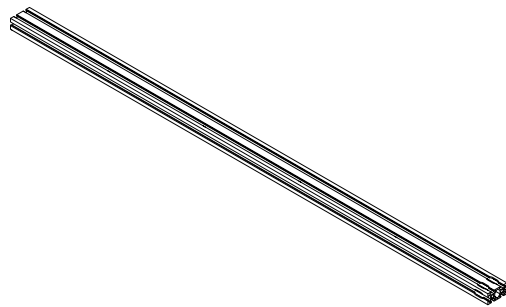

CROSSBAR
QTY-6

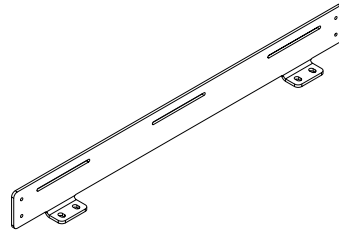

MIDDLE RAIL QTY-2

HARDWARE PACK

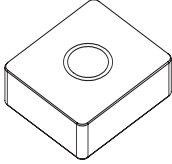
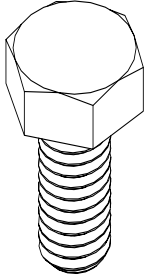
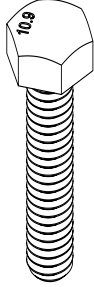
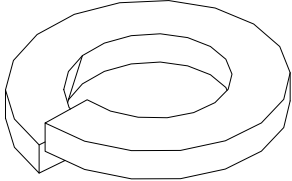
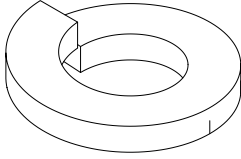
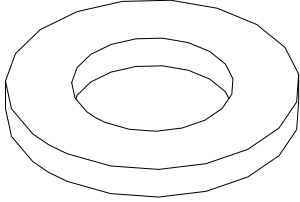
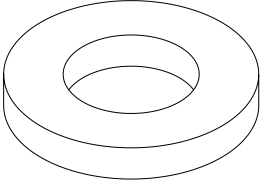
AADP170	 <p>RAIL NUT QTY-32</p>	 <p>M10-20 HEXGON HEAD SCREW QTY-32</p>	 <p>M6-25 HEXGON HEAD SCREW QTY-32</p>	
		 <p>M10 SPRING LOCK WASHER QTY-32</p>	 <p>M6 SPRING LOCK WASHER QTY-32</p>	
		 <p>M10 WASHER QTY-32</p>	 <p>M6 WASHER QTY-32</p>	

LET'S GET STARTED!

1. SLIDE HALF OF THE RAIL NUTS INTO THE PASSENGER SIDE FACTORY ROOF RAIL, AND HALF OF THEM INTO THE DRIVER SIDE RAIL.
2. SPACE OUT THE RAIL NUTS CLOSE TO THE FINAL POSITION (GROUPS OF 2) SEE **FIGURE 1** FOR ROUGH REFERENCE DIMENSIONS.

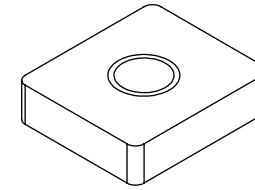

RAIL NUT
QTY-24

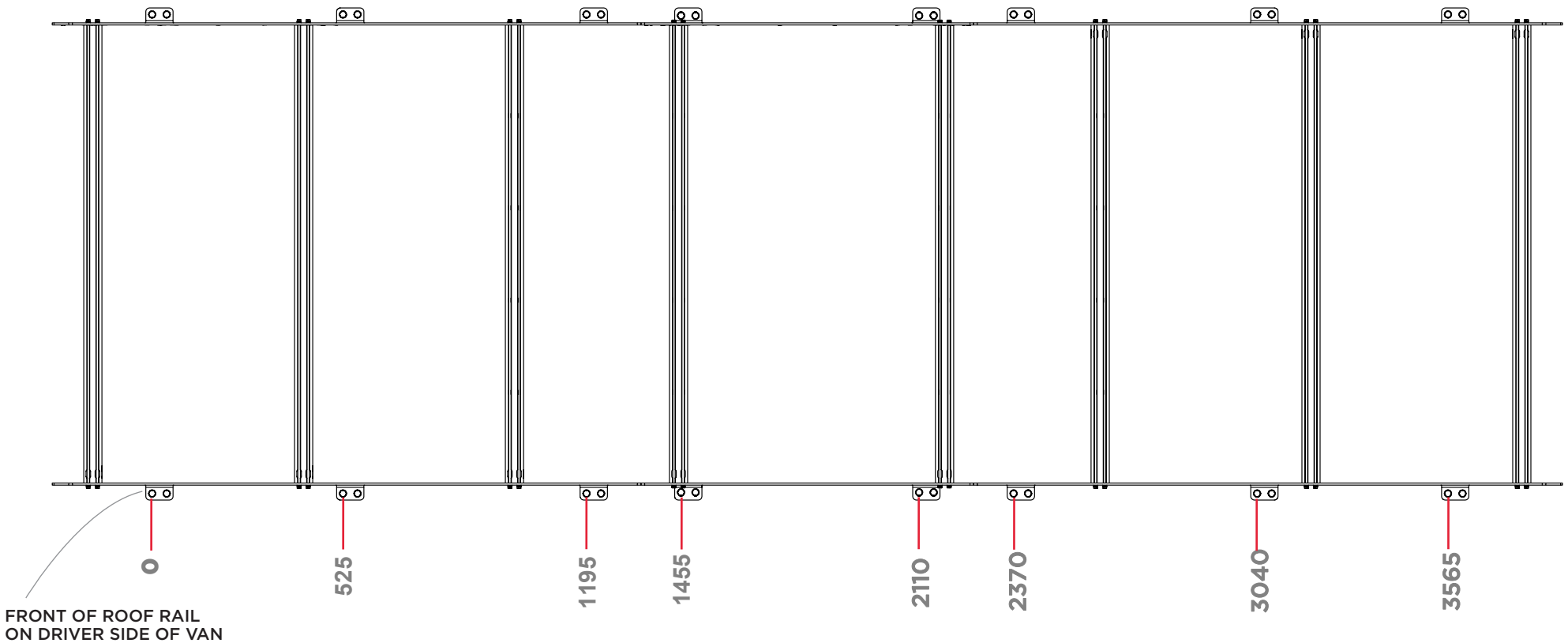

USE THESE DIMENSIONS FOR ROUGH REFERENCE ONLY (UNIT: mm) F

START *LOOSELY* ATTACHING THE SIDE RAILS TO THE ROOF RAILS
USING THE **M10-20 HEXAGON HEAD SCREW & M10 SPRING LOCK WASHERS**
& **M10 WASHERS**, BUT DO NOT TIGHTEN ALL THE WAY DOWN.

(SEE **FIGURE 3** FOR DETAIL)

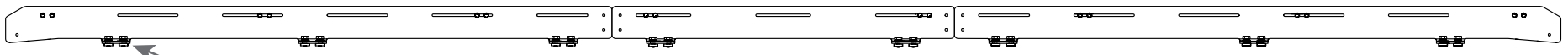

NOTE- FRONT "FOOT" OF
RACK SHOULD BE AS
FAR FORWARD IN ROOF
RAIL AS IT CAN GO.

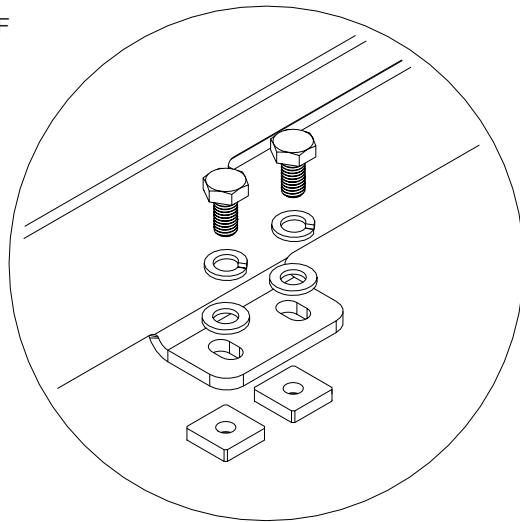

FIGURE 3

4. PLACE YOUR CROSSBARS IN DESIRED LOCATION, LOOSELY BOLTING THE M6-25 HEXAGON HEAD SCREWS & M6 SPRING LOCK WASHERS & M6 WASHERS IN PLACE.

FIGURE 4

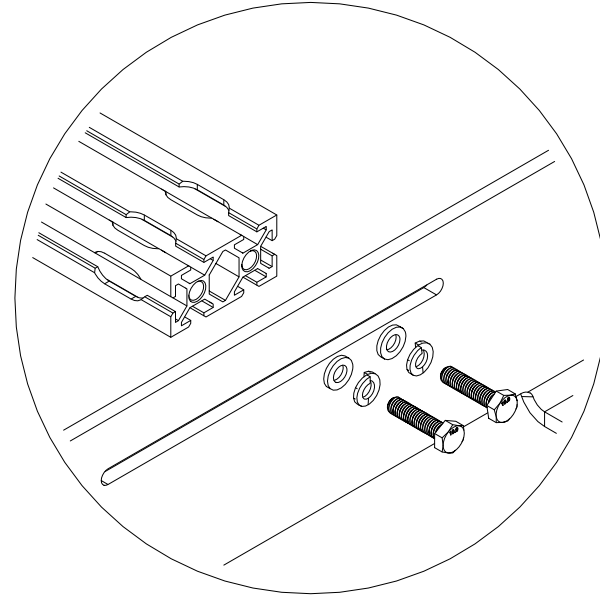
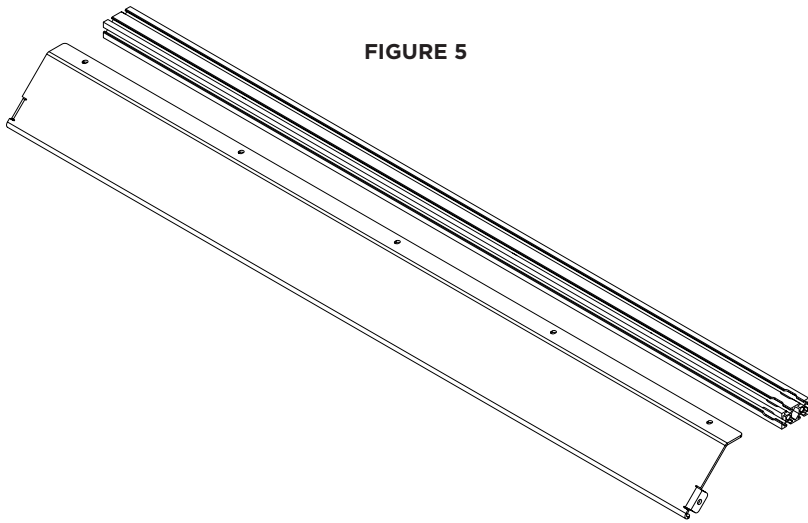
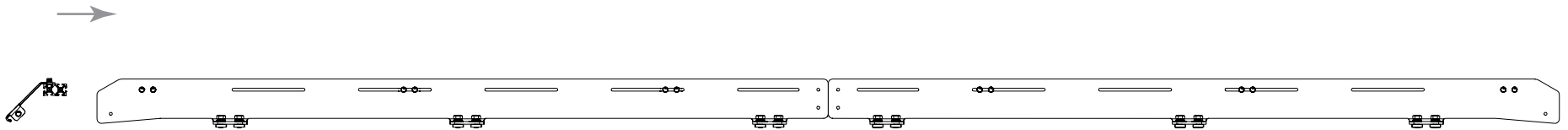

FIGURE 5



NOTE- IF INSTALLING OUR FRONT FAIRING; IT IS SUGGESTED TO BOLT THE FAIRING TO THE CROSSBAR FIRST (SEE FIGURE 5), THEN ATTACH THAT ASSEMBLY TO THE ROOF RACK (SEE FIGURE 6)

FIGURE 6



5. TIGHTEN ALL CROSSBAR BOLTS USING THE 10 mm WRENCH
- NOTE- DO NOT OVERTIGHTEN!** IF YOU ARE CONCERNED ABOUT THE BOLTS BACKING OUT, YOU CAN PUT A DAB OF BLUE LOCTITE ON THE BOLTS BEFORE TIGHTENING DOWN COMPLETELY.

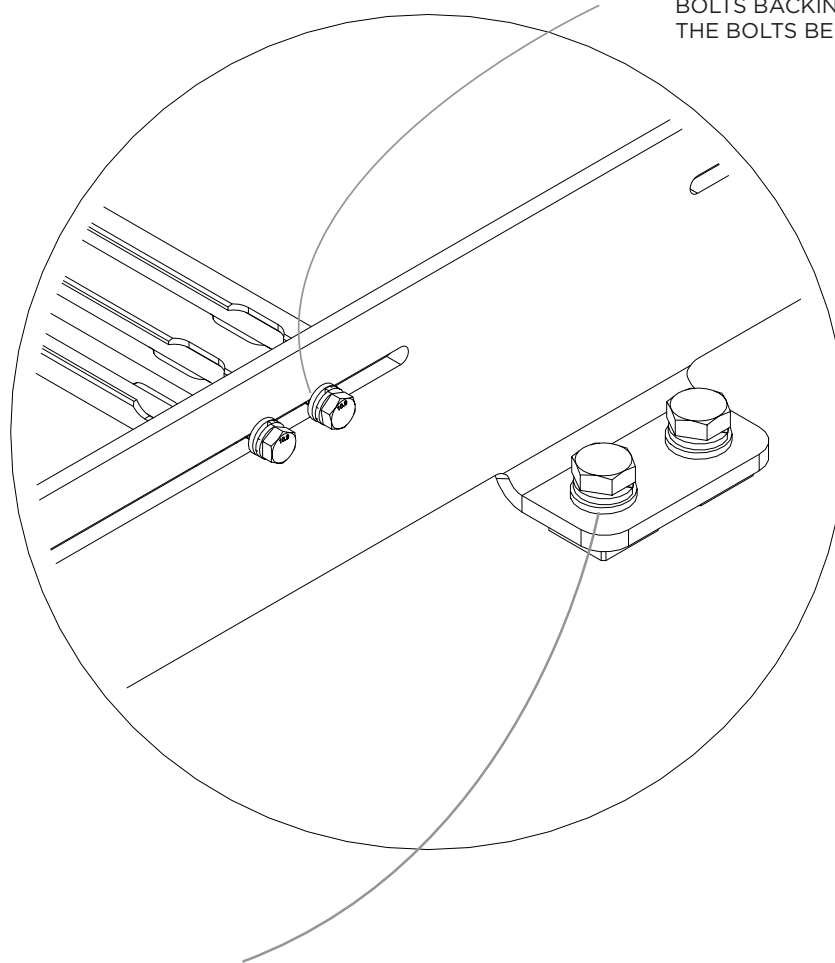

6. NOW TIGHTEN SIDE RAILS TO ROOF RAIL USING THE 17 mm WRENCH