

WTA



Installation Guide

Sprinter Stealth Roof Rack 144

Ensuring the proper assembly and secure attachment of all WTA products to your vehicle is of utmost importance. Failure to adhere to these guidelines may lead to automobile accidents, presenting a substantial risk of bodily harm or even fatality to yourself and others. As the owner, it is incumbent upon you to meticulously assemble and secure WTA products, conducting a thorough examination of the mounting points and attachments before use, and routinely checking for any indications of wear or damage.

To ensure optimal safety, we strongly recommend enlisting the services of a qualified installer for the installation of any aftermarket accessories on your vehicle. If you lack mechanical expertise or are unfamiliar with the installation procedures, it is crucial to have the product installed by a certified professional or individuals with the requisite skills. Remember, the responsibility rests with you, and it must be approached with seriousness to safeguard the well-being of all individuals involved.

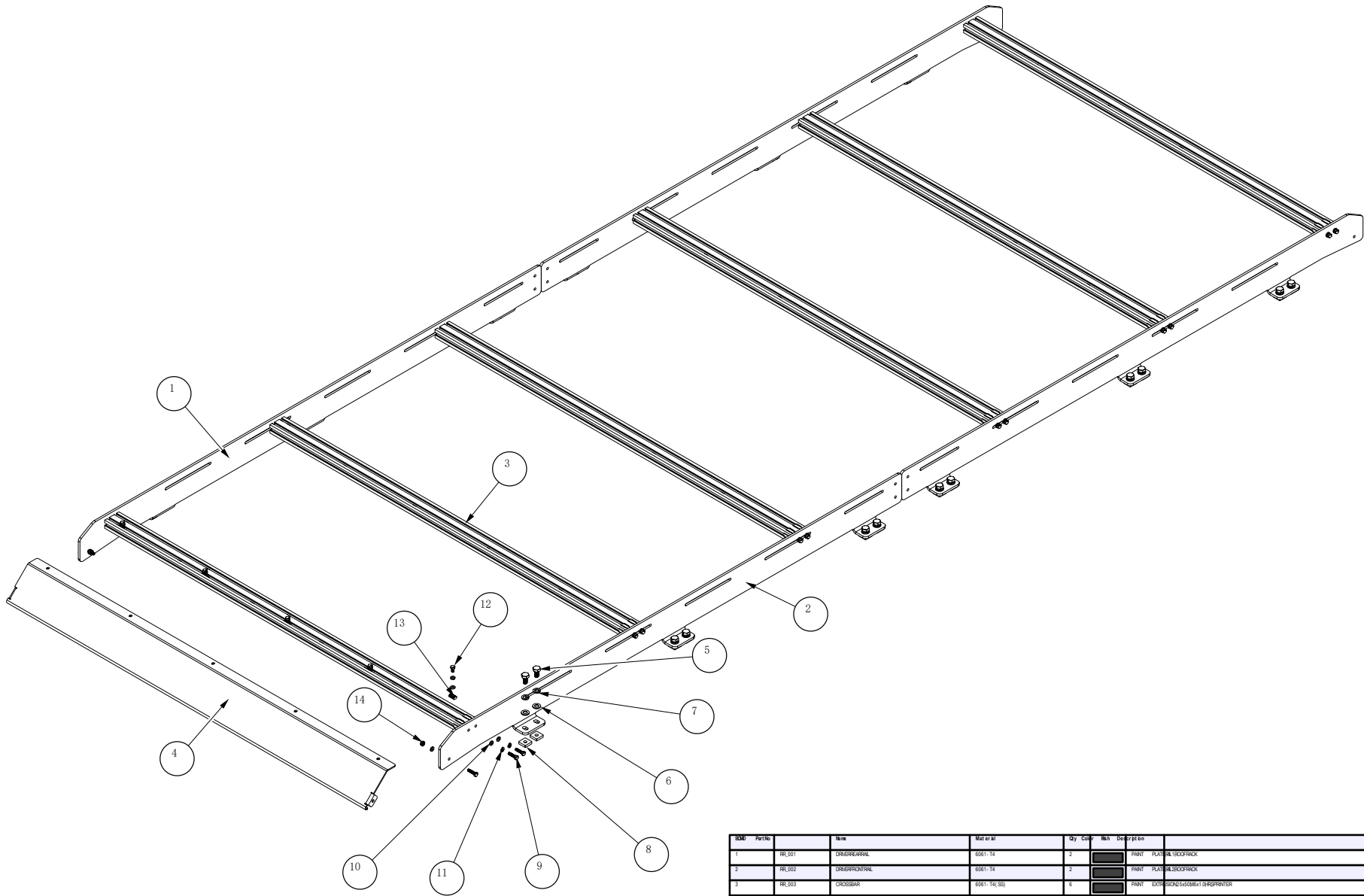

ID#	Part No	Name	Material	Qty	Col	Unit	Description	Assembly
1	RR_001	DRIVER/RAMP	6061-T4	2			PWNT PLAT BLK/ROOF/BLACK	SPR8144
2	RR_002	DRIVER/CENTRAL	6061-T4	2			PWNT PLAT BLK/ROOF/BLACK	SPR8144
3	RR_003	CROSSBAR	6061-T4(SS)	6			PWNT EXTR BLK/245MMX1.088SPRINTER	旅行架总装图
4	RR_006	RRIC	6061-T4	1			PWNT	SPR8144
5	HW_B001	SLUR/NO.1	18-SSstainless Steel	24			SCREEN/EXCAP/NOV1.020MSS/SS4BEC	旅行架总装图
6	HW_W001	WASHER/NO.1	Steel	24			WASHER/LAT/1.020MSS/SS4BEC	SPR8144
7	HW_W002	SPRINZ/NO.1	AW04	24			WASHER/LAT/1.020MSS/SS4BEC	SPR8144
8	HW_N001	NUT/NO.1	AW003	24			NUT/LAT/NOV1.020MSS/SS4BEC/COMP	SPR8144
9	HW_B002	SLUR/NO.2	AW04	26			SCREEN/EXCAP/NOV1.020MSS/SS4BEC	SPR8144
10	HW_W003	WASHER/NO.2	AW04	37			WASHER/LAT/1.020MSS/SS4BEC	SPR8144
11	HW_W004	SPRINZ/NO.2	AW04	29			WASHER/LAT/1.020MSS/SS4BEC	SPR8144
12	HW_B003	SLUR/NO.3	AW04	5			SCREEN/EXCAP/NOV1.020MSS/SS4BEC	SPR8144
13	HW_N002	SLUR/NO.2	AW04	5			SCREEN/EXCAP/NOV1.020MSS/SS4BEC	旅行架总装图
14	HW_N002	LOD/NUT/NO.1	18-SSstainless Steel	2			NUT/LOD/MS/SEC	旅行架总装图

THANK YOU!

- PLEASE INSPECT THE PRODUCT TO ENSURE THERE WAS NO DAMAGE INCURRED DURING SHIPPING.
- IF THERE IS DAMAGE TO REPORT, PLEASE CONTACT OUR CUSTOMER SERVICE DEPARTMENT AS SOON AS POSSIBLE.
- NEXT, USING THE “PACKAGE CONTENTS” PAGE, CHECK INVENTORY AND FAMILIARIZE YOURSELF WITH THE PARTS AND HARDWARE.
- GATHER ALL TOOLS REQUIRED FOR INSTALL.
 - 10 mm WRENCH
 - 17 mm WRENCH

TOOLS

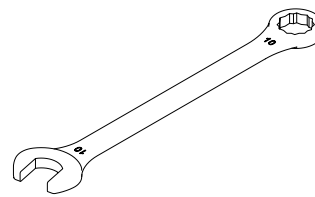

10 mm Wrench

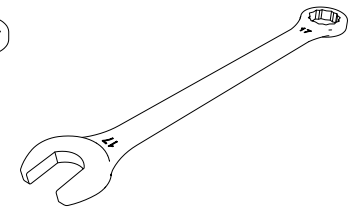

17 mm Wrench

PACKAGE CONTENTS

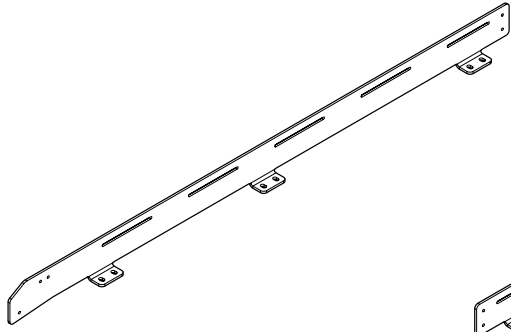

DRIVER FRONT RAIL
QTY-1

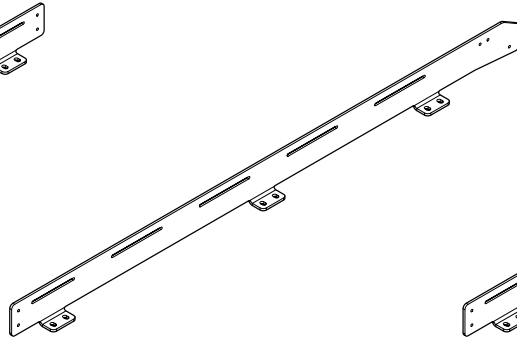

DRIVER REAR RAIL
QTY-1

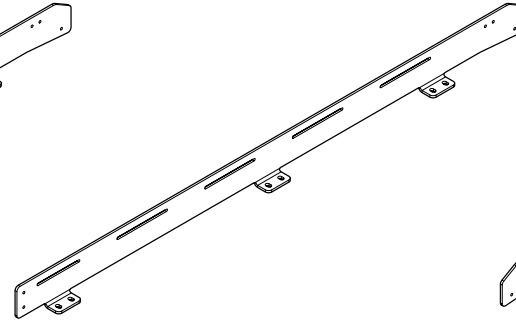

PASSENGER FRONT RAIL
QTY-1

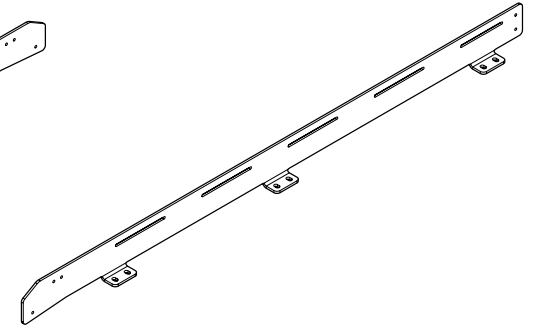

PASSENGER REAR RAIL
QTY-1

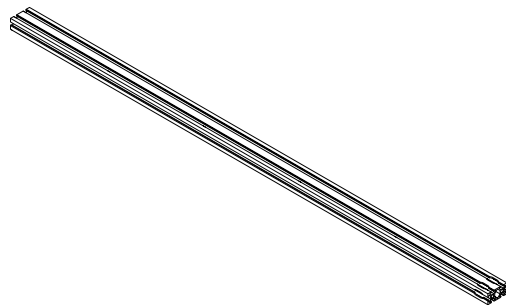

CROSSBAR
QTY-6

HARDWARE PACK

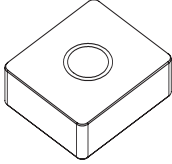
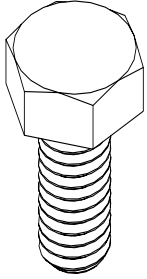
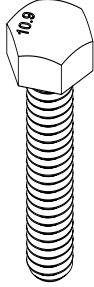
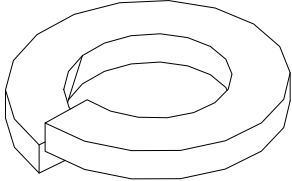
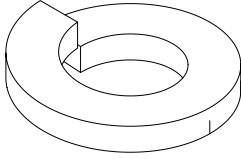
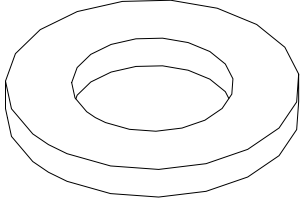
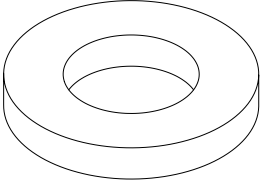
SPRR144	 <p>RAIL NUT QTY-24</p>	 <p>M10-20 HEXAGON HEAD SCREW QTY-24</p>	 <p>M6-25 HEXAGON HEAD SCREW QTY-24</p>	
		 <p>M10 SPRING LOCK WASHER QTY-24</p>	 <p>M6 SPRING LOCK WASHER QTY-24</p>	
		 <p>M10 WASHER QTY-24</p>	 <p>M6 WASHER QTY-24</p>	

LET'S GET STARTED!

1. SLIDE HALF OF THE RAIL NUTS INTO THE PASSENGER SIDE FACTORY ROOF RAIL, AND HALF OF THEM INTO THE DRIVER SIDE RAIL.
2. SPACE OUT THE RAIL NUTS CLOSE TO THE FINAL POSITION (GROUPS OF 2) SEE **FIGURE 1** FOR ROUGH REFERENCE DIMENSIONS.

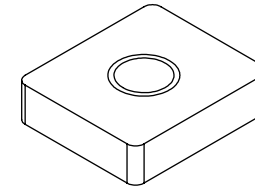

RAIL NUT
QTY-24

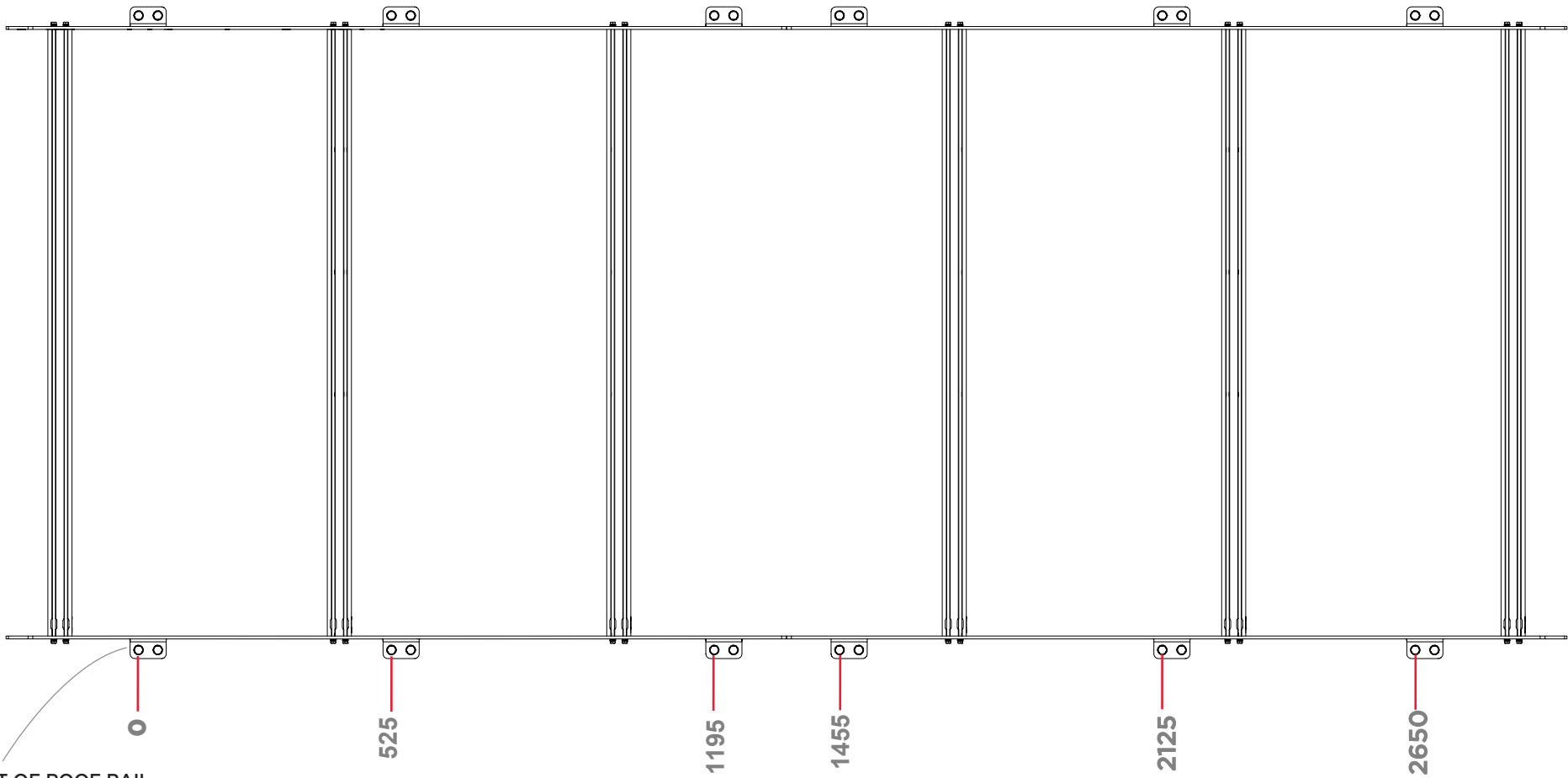

FRONT OF ROOF RAIL
ON DRIVER SIDE OF VAN

USE THESE DIMENSIONS FOR ROUGH REFERENCE ONLY (UNIT: mm)

START *LOOSELY* ATTACHING THE SIDE RAILS TO THE ROOF RAILS
USING THE **M10-20 HEXAGON HEAD SCREW & M10 SPRING LOCK WASHERS**
& **M10 WASHERS**, BUT DO NOT TIGHTEN ALL THE WAY DOWN.
(SEE **FIGURE 3** FOR DETAIL)

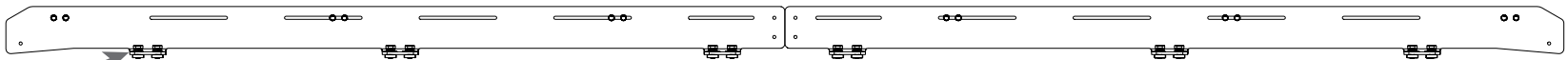

NOTE- FRONT "FOOT" OF
RACK SHOULD BE AS
FAR FORWARD IN ROOF
RAIL AS IT CAN GO.

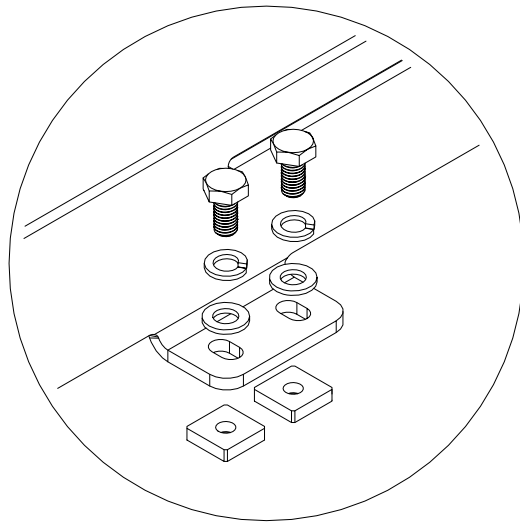

FIGURE 3

4. PLACE YOUR CROSSBARS IN DESIRED LOCATION, LOOSELY BOLTING THE M6-25 HEXAGON HEAD SCREWS & M6 SPRING LOCK WASHERS & M6 WASHERS IN PLACE.

FIGURE 4

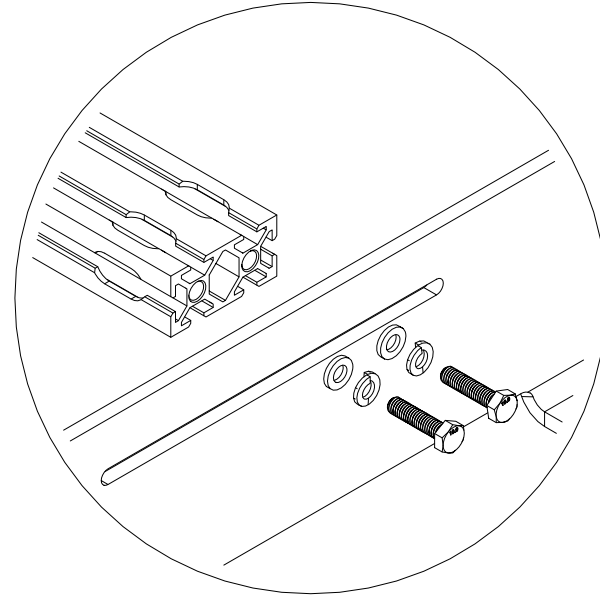
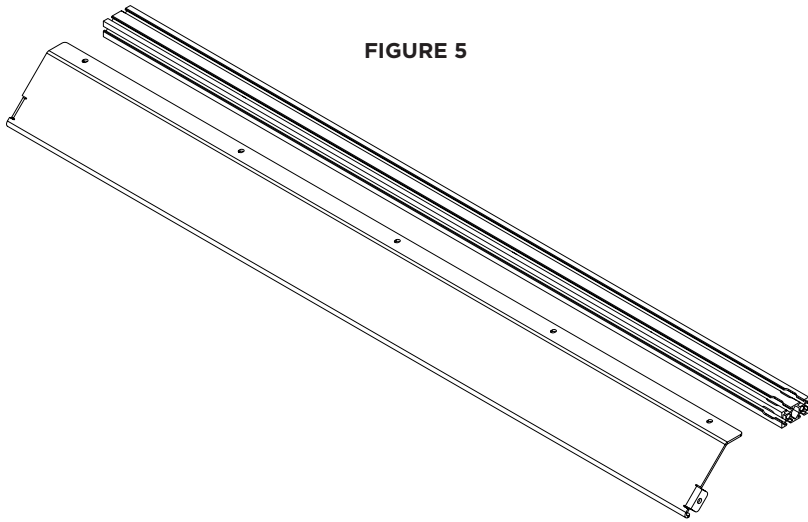
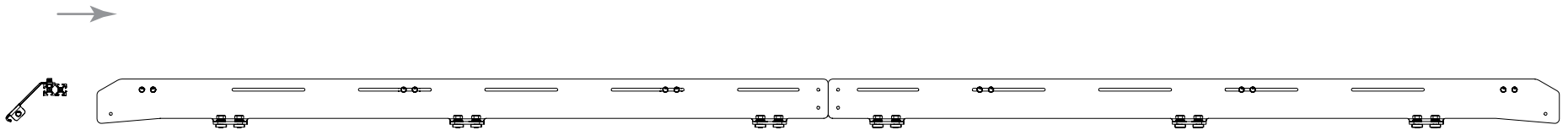

FIGURE 5



NOTE- IF INSTALLING OUR FRONT FAIRING; IT IS SUGGESTED TO BOLT THE FAIRING TO THE CROSSBAR FIRST (SEE FIGURE 5), THEN ATTACH THAT ASSEMBLY TO THE ROOF RACK (SEE FIGURE 6)

FIGURE 6



5. TIGHTEN ALL CROSSBAR BOLTS USING THE 10 mm WRENCH
- NOTE- DO NOT OVERTIGHTEN!** IF YOU ARE CONCERNED ABOUT THE BOLTS BACKING OUT, YOU CAN PUT A DAB OF BLUE LOCTITE ON THE BOLTS BEFORE TIGHTENING DOWN COMPLETELY.

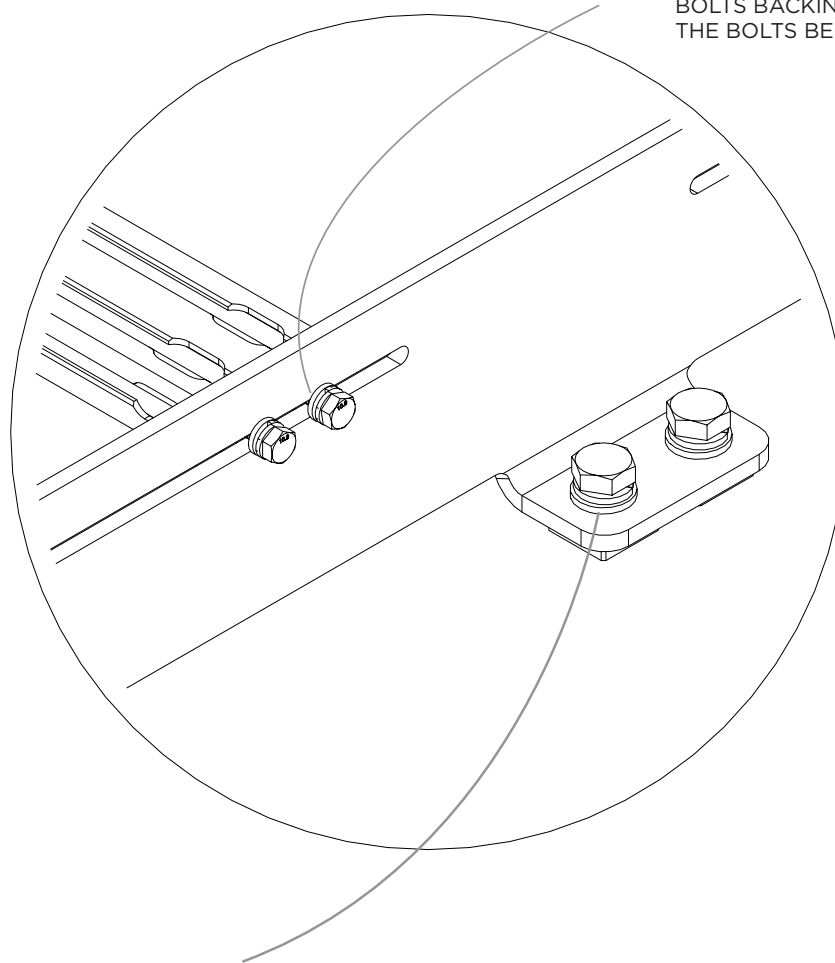

6. NOW TIGHTEN SIDE RAILS TO ROOF RAIL USING THE 17 mm WRENCH