

# WTA



## Installation Guide

# Sprinter 148 High Roof Strata Roof Rack

## SPRR148

**Ensuring the proper assembly and secure attachment of all WTA products to your vehicle is of utmost importance. Failure to adhere to these guidelines may lead to automobile accidents, presenting a substantial risk of bodily harm or even fatality to yourself and others. As the owner, it is incumbent upon you to meticulously assemble and secure WTA products, conducting a thorough examination of the mounting points and attachments before use, and routinely checking for any indications of wear or damage.**

**To ensure optimal safety, we strongly recommend enlisting the services of a qualified installer for the installation of any aftermarket accessories on your vehicle. If you lack mechanical expertise or are unfamiliar with the installation procedures, it is crucial to have the product installed by a certified professional or individuals with the requisite skills. Remember, the responsibility rests with you, and it must be approached with seriousness to safeguard the well-being of all individuals involved.**

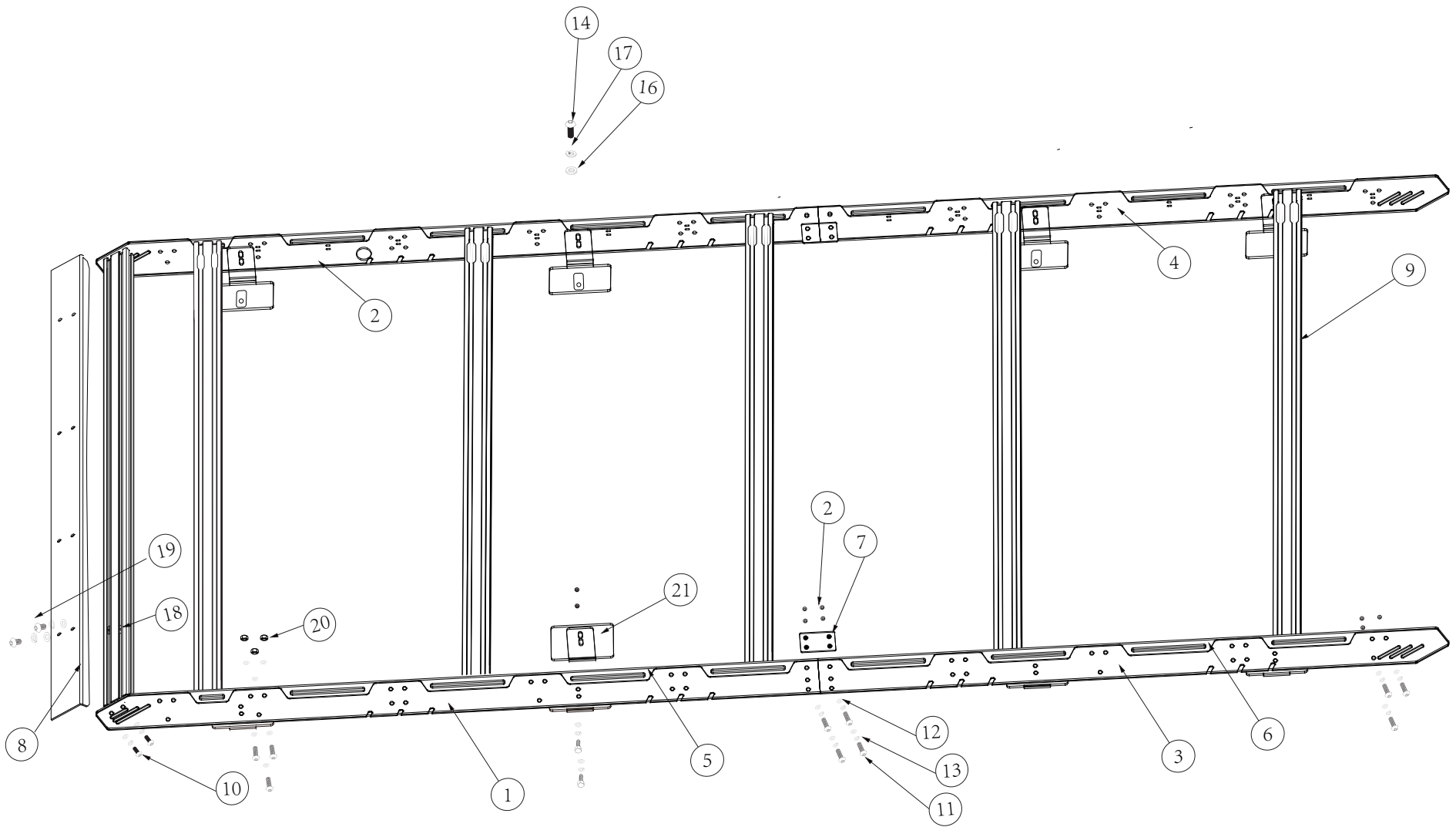

DESCRIPTION	BOM	QTY	DESCRIPTION	BOM	QTY	DESCRIPTION	BOM	QTY
RIVER FRONT RAIL	1	1	CROSSBAR	9	6	M10 SPRING LOCK WASHER	17	1
PASSENGER FRONT RAIL	2	2	M 8 - 20 HEXAGON SOCKET BUTTON HEAD SCREW	10	2	T SLIDE NUT	18	2
RIVER REAR RAIL	3	3	M 8 - 25 HESGON SOCKET BUTTON HEAD SCREW	11	3	M8-12 HEXAGON SOCKET BUTTON HEAD SCREW	19	3
PASSENGER REAR RAIL	4	4	M 8 *16 FLAT WASHER	12	4	LOCK NUT	20	4
FRONT ARMOR PLATE	5	5	M 8 SPRRING LOCK WASHER	13	5		21	
REAR ARMOR PLATE	6	6	M 10-22 HEXAGON HEAD SCREW	14	6			
JOINT PLATE	7	7	SQUARE NUT	15	7			
FAIRING PLATE	8	8	M10 FLAT WASHER	16	8			

# THANK YOU!

- PLEASE INSPECT THE PRODUCT TO ENSURE THERE WAS NO DAMAGE INCURRED DURING SHIPPING.
- IF THERE IS DAMAGE TO REPORT, PLEASE CONTACT OUR CUSTOMER SERVICE DEPARTMENT AS SOON AS POSSIBLE.
- NEXT, USING THE “PACKAGE CONTENTS” PAGE, CHECK INVENTORY AND FAMILIARIZE YOURSELF WITH THE PARTS AND HARDWARE.
- GATHER ALL TOOLS REQUIRED FOR INSTALL.
  - 10 mm WRENCH
  - 17 mm WRENCH

## TOOLS

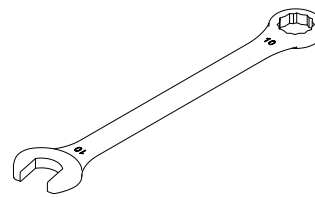

10 mm Wrench

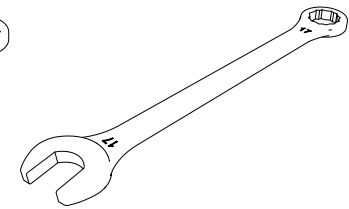

17 mm Wrench

# PACKAGE CONTENTS

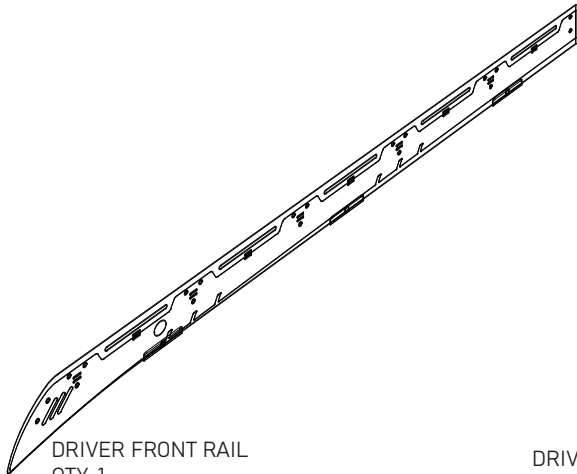

DRIVER FRONT RAIL  
QTY-1

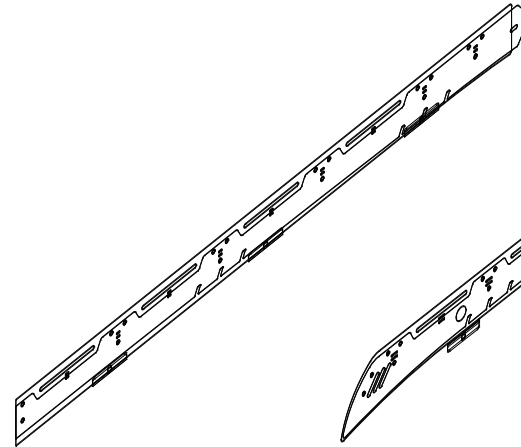

DRIVER REAR RAIL  
QTY-1

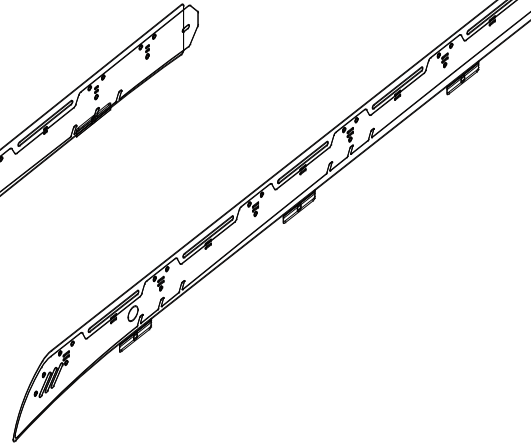

DRIVER REAR RAIL  
QTY-1

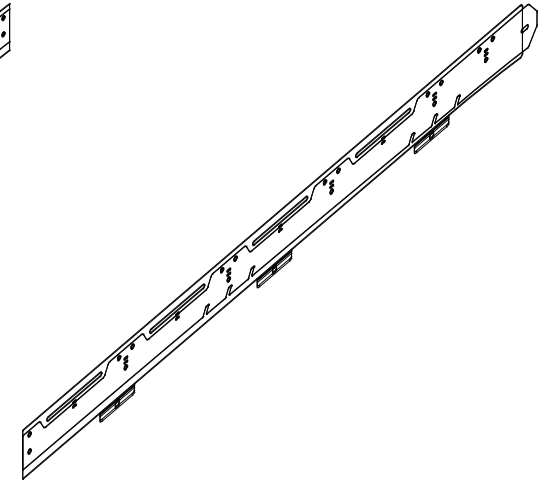

PASSENGER FRONT RAIL  
QTY-1

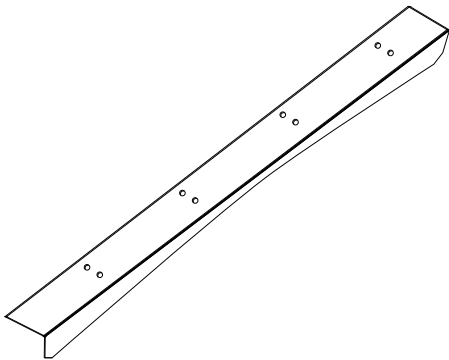

FAIRING  
QTY-1

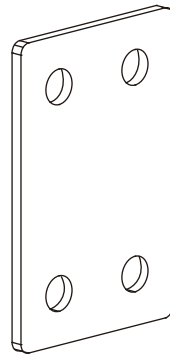

SQUARE NUT  
QTY-6

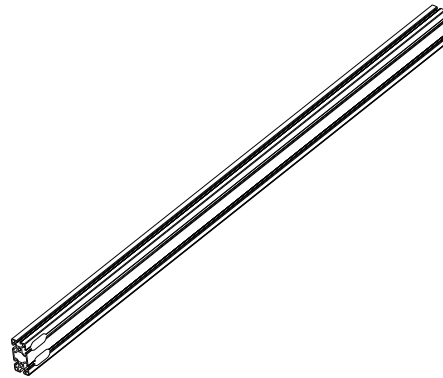

CROSSBAR  
QTY-6

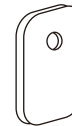

WASHER  
QTY-6

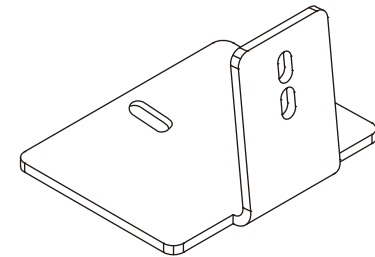

L-BRACKET  
QTY-6

# HARDWARE PACK

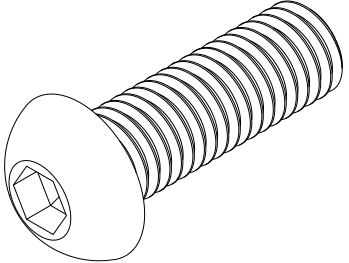
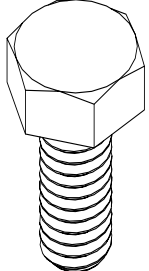
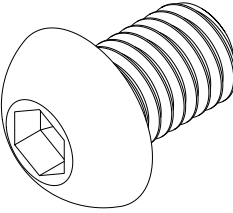
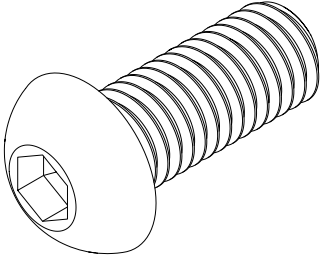
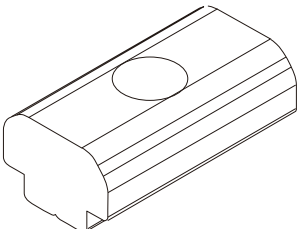
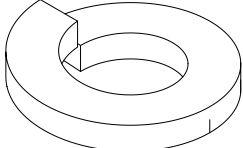
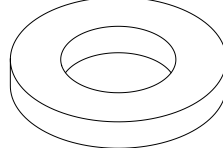
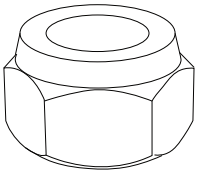
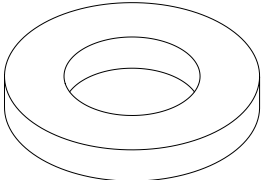
<b>SPRR148-J</b>	 <p>M8-25 HEXGON SOCKET BUTTON HEAD SCREW QTY-48</p>	 <p>M8-30 HEXGON HEAD SCREW QTY-8</p>	 <p>M6-12 HEXGON SOCKET BUTTON HEAD SCREW QTY-8</p>	 <p>M8-20 HEXGON SOCKET BUTTON HEAD SCREW QTY-8</p>
	 <p>TBLOCK QTY-8</p>	 <p>M8 SPRING LOCK WASHER QTY-24</p>	 <p>M6 WASHER QTY-8</p>	
	 <p>LOCK NUT QTY-32</p>	 <p>M8 WASHER QTY-88</p>		

# LET'S GET STARTED!

1. SLIDE HALF OF THE RAIL NUTS INTO THE PASSENGER SIDE FACTORY ROOF RAIL, AND HALF OF THEM INTO THE DRIVER SIDE RAIL.
2. SPACE OUT THE RAIL NUTS CLOSE TO THE FINAL POSITION (GROUPS OF 2) SEE FIGURE 1 FOR ROUGH REFERENCE DIMENSIONS.

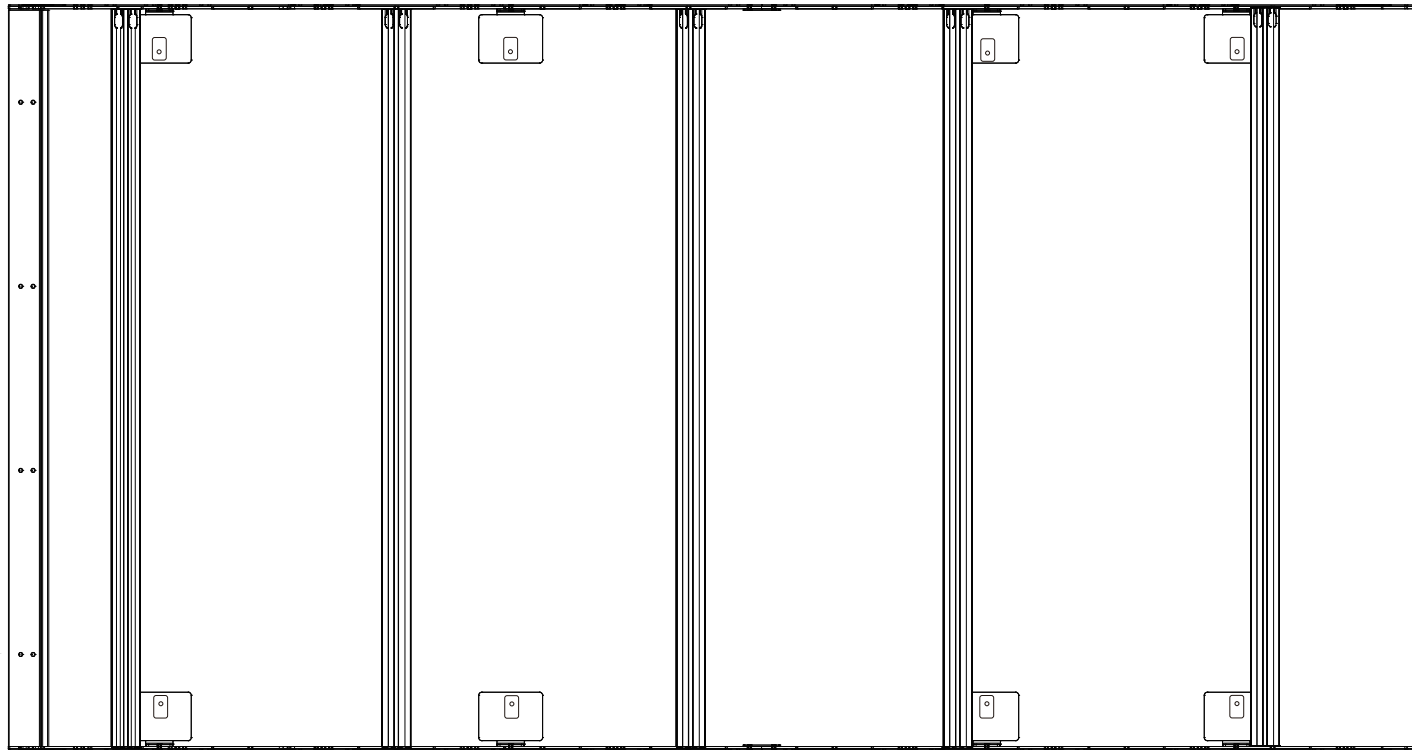

FRONT OF ROOF RAIL  
ON DRIVER SIDE OF VAN

3. BEGIN PLACING THE RAILS ON THE ROOF. THE RAIL WITH THE FCC BADGE SHOULD GO ON THE DRIVER SIDE OF THE CAN IN THE REAR LOCATION. ALL OF THE RAILS ARE UNIQUE TO ACCOMMODATE DIFFERENT LADDERS AND PLACEMENTS. START LOOSE LATTACHING THE SIDE RAILS TO THE ROOF RAILS USING THE M8-30 HEXAGON HEAD SCREW & M8 SPRING LOCK WASHERS & M8 WASHERS BUT DO NOT TIGHTEN ALL THE WA DOWN. (SEE FIGURE 1 FOR DETAIL)

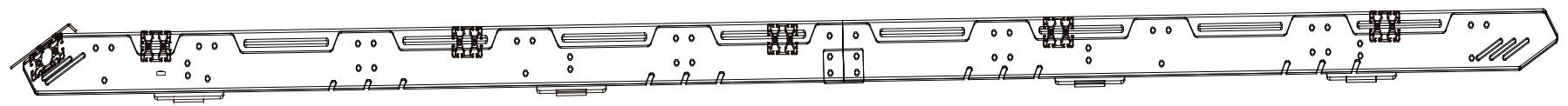

NOTE- FRONT "FOOT" OF RACK SHOULD BE AS FAR FORWARD IN ROOF RAIL AS IT CAN GO.

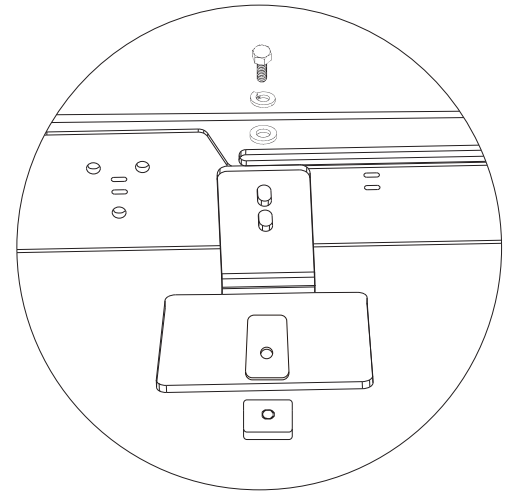

FIGURE 1

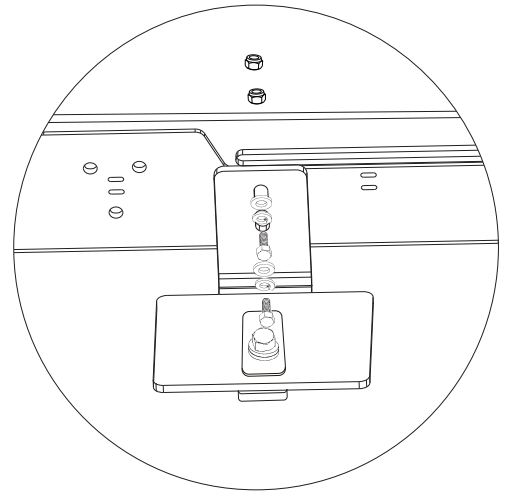

FIGURE 2

4. PLACE YOUR CROSSBARS IN DESIRED LOCATION, LOOSELY BOLTING THE M8-20 HEXGON HEAD SCREWS & M8 SPRING LOCK WASHERS & M8 WASHERS IN PLACE

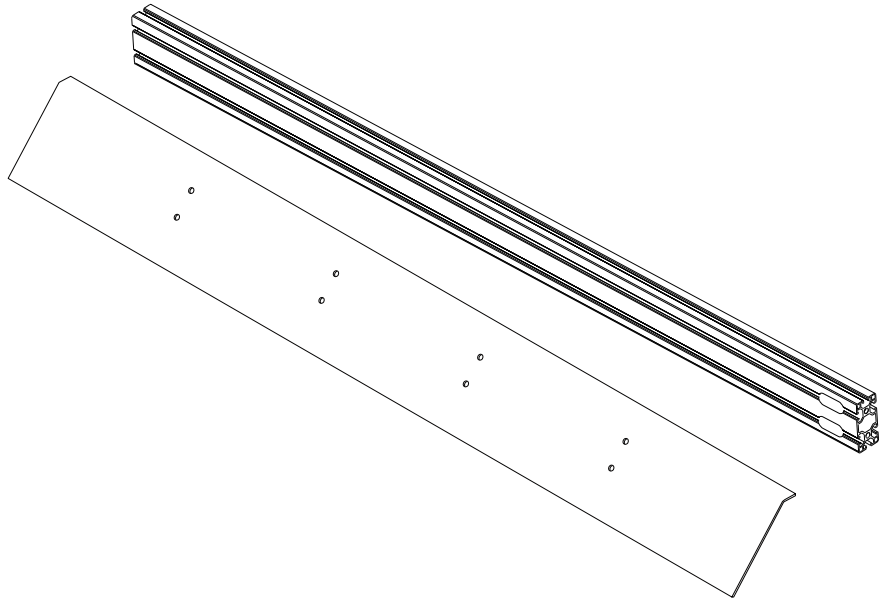

FIGURE 5

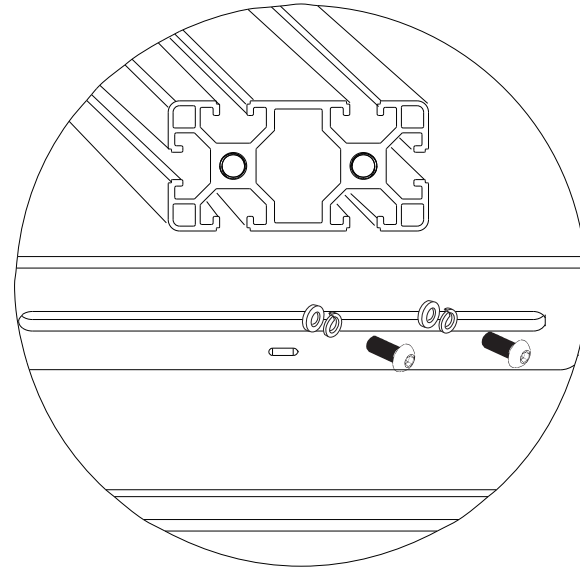

FIGURE 4

**NOTE-** IF INSTALLING OUR FRONT FAIRING; IT IS SUGGESTED TOO BOLT THE FAIRING TO THE CROSSBAR FIRST (SEE FIGURE 5), THEN ATTACH THAT ASSEMBLY TO THE ROOF RACK (SEE FIGURE 6)

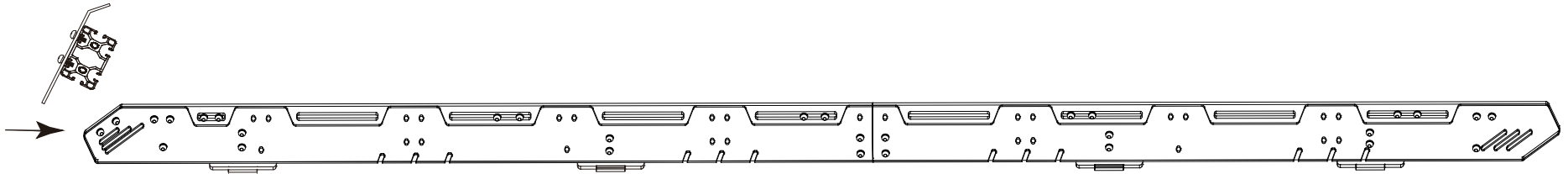
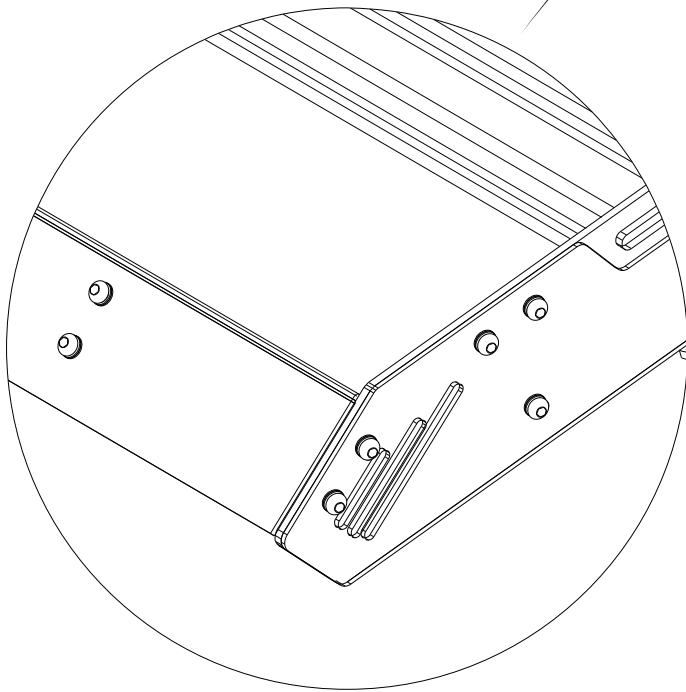

FIGURE 6



5. TIGHTEN ALL CROSSBAR BOLTS USING THE 10 mm WRENCH  
**NOTE-** DO NOT OVERTIGHTEN! IF YOU ARE CONCERNED ABOUT THE BOLTS BACKING OUT, YOU CAN PUT A DAB OF BLUE LOCTITE ON THE BOLTS BEFORE TIGHTENING DOWN COMPLETELY.



6. NOW TIGHTEN SIDE RAILS TO ROOF RAIL USING THE 17 mm WRENCH

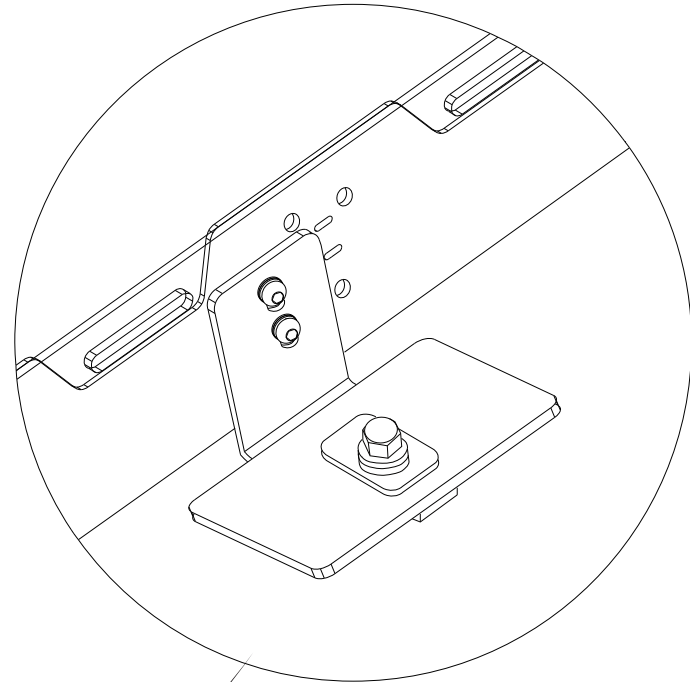

# GET THERE WITH WHITE TOP ADVENTURES



thanks!



[info@whitetopadventures.com](mailto:info@whitetopadventures.com)