

GRATZ™ PILATES

CLASSIC & DESIGNER

REFORMER

ASSEMBLY INSTRUCTIONS

MADE IN THE U.S.A. | PILATES-GRATZ.COM



GRATZ INDUSTRIES, LLC

1108 SHACKAMAXON STREET
PHILADELPHIA, PENNSYLVANIA, 19125
215.739.7373 or 1.800.930.9900

Assembling Your Universal Reformer

These instructions will show you how to assemble and set up your Universal Reformer. Please make sure you have all the items out of the box listed below and you will need the items listed on the following page to complete assembly.

What Comes In The Box

- (A) 1 Reformer Frame with 1 padded foot bar
- (B) 1 Carriage with 4 springs & 2 leather straps
- (C) 2 Aluminum & Wood Handles
- (D) 1 Weighted Pole
- (E) 1 Upholstered long/short reformer box
- (F) 1 Spring Bar
- (G) 2 Thick rubber pads
- (H) 2 Gear stoppers
- (I) 2 20" Foot Straps
- (J) 2 27" Extensions Straps

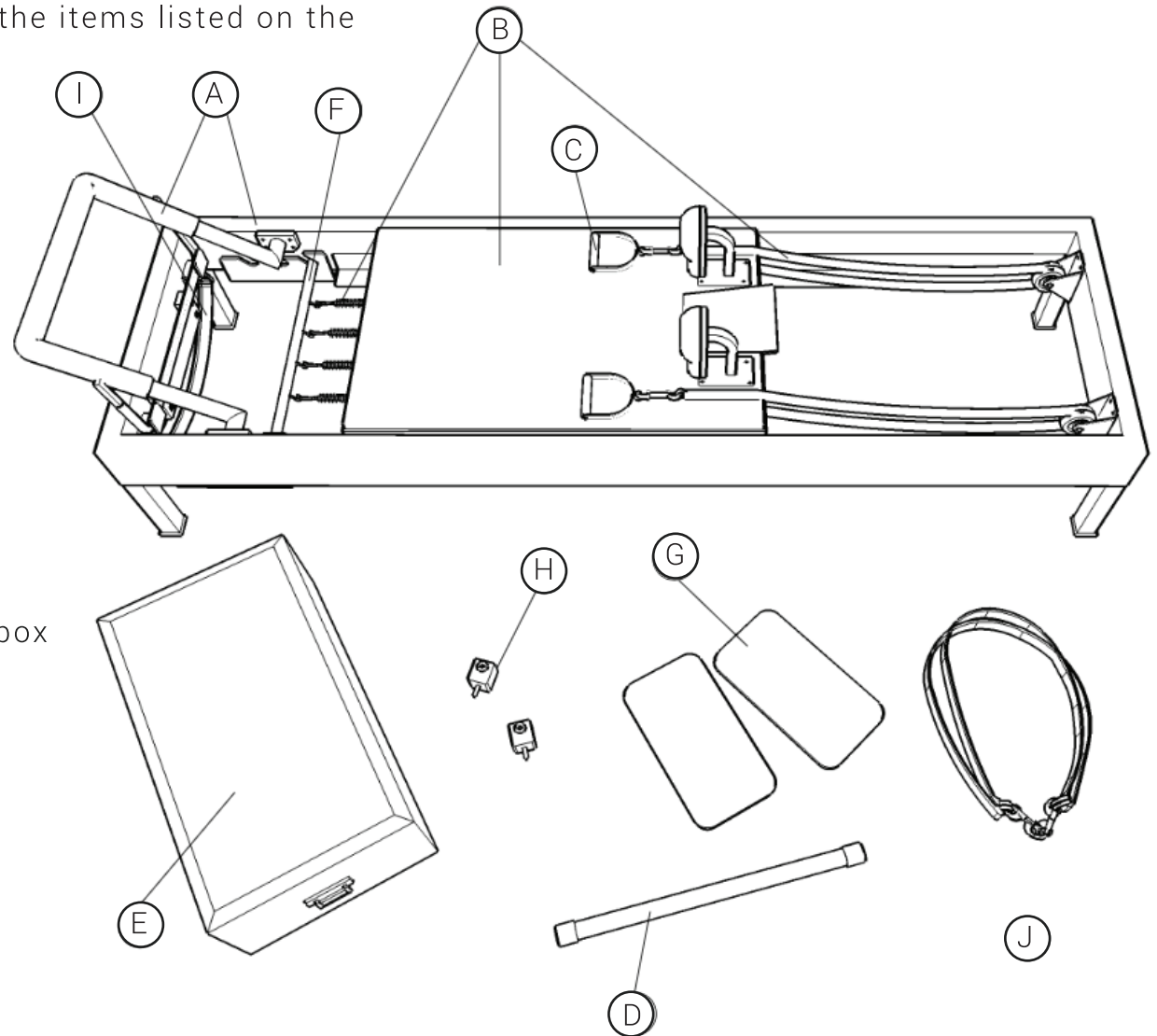

IMPORTANT: Two people are required to set up your Universal Reformer.

Gratz Industries is not responsible for any damages to the Universal Reformer that is caused by improper set up or installation.

STEP 1 - Remove Contents From Box

Place the box long-side down. Use the scissors to carefully cut ties. Three packed bundles should be in the box with everything shown page 1. If there is anything missing or damaged from your box please let us know right way so that a remedy can be made.

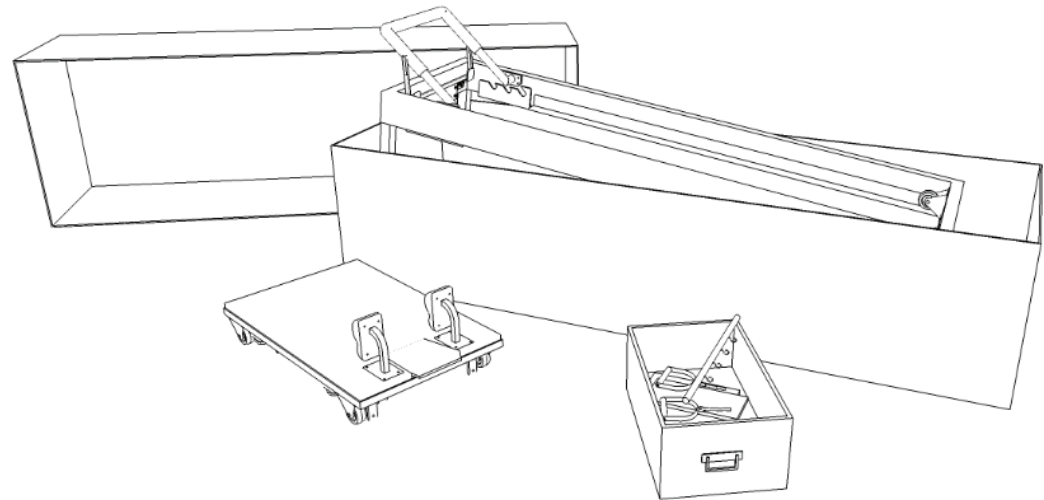

What You Will Need

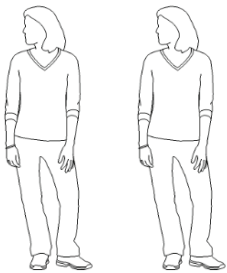

Two People



Boxcutter

IMPORTANT: Two people are required to set up your Universal Reformer. Gratz Industries is not responsible for any damages to the Universal Reformer that is caused by improper set up or installation.

STEP 2 - Place Spring Bar On Frame

Locate the spring bar in the box and the gears on the reformer frame. Then place the spring bar in the preferred gear with the hooks facing away from the footbar.

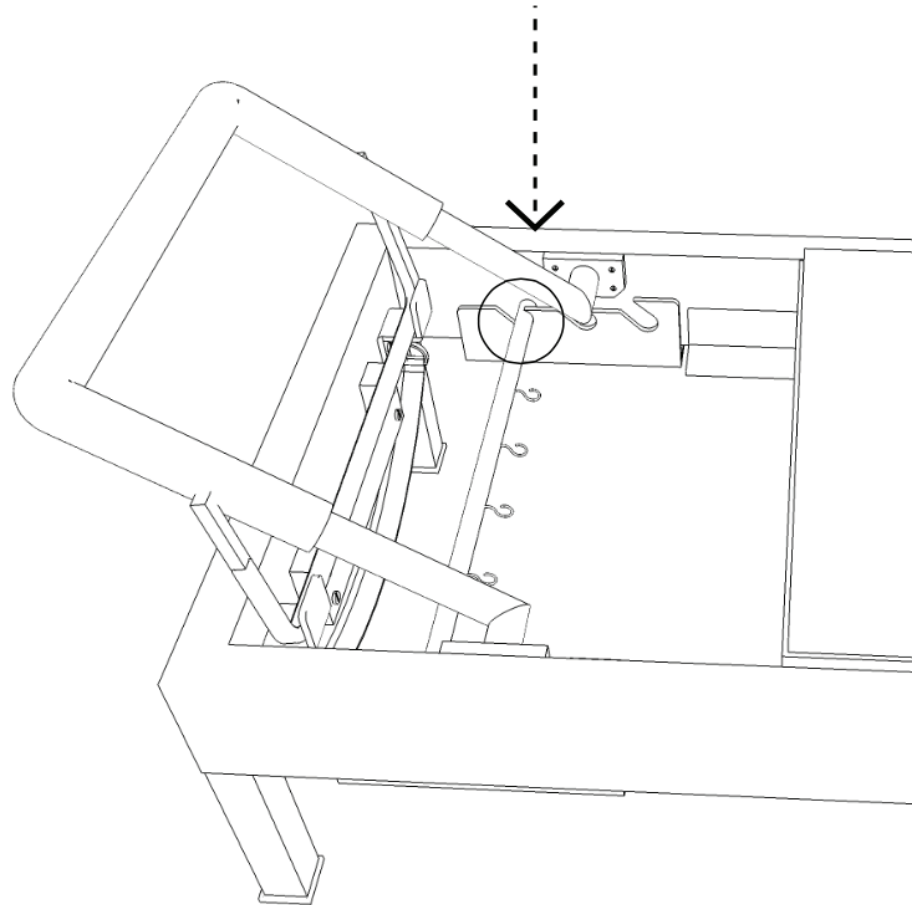

IMPORTANT: Two people are required to set up your Universal Reformer.
Gratz Industries is not responsible for any damages to the Universal Reformer that is caused by improper set up or installation.

STEP 3 - Place The Carriage On The Reformer

Locate the carriage and reformer rails. Place the carriage on the reformer rails with the carriage springs facing the spring bar (see **Figure A**). Then hook the carriage springs to the spring bar (see **Figure B**). Feed the leather straps through the wheel guides (see **Figure C**). Finish up by hooking the leather straps to the handles (see **Figure D**).

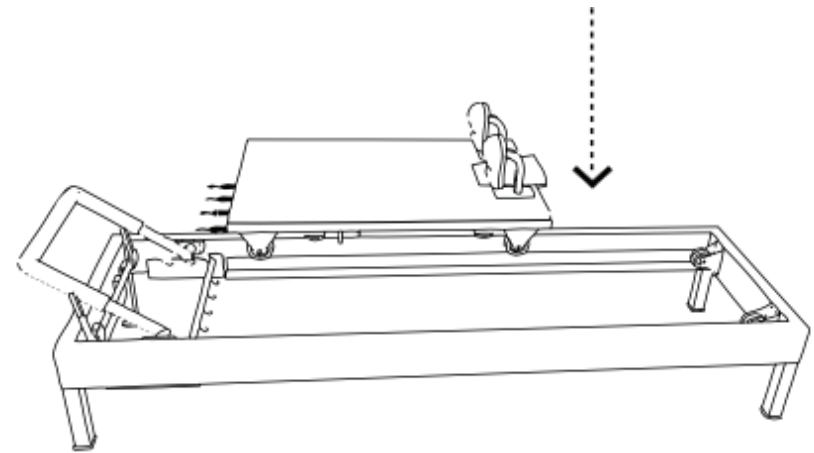

Figure A

Figure B

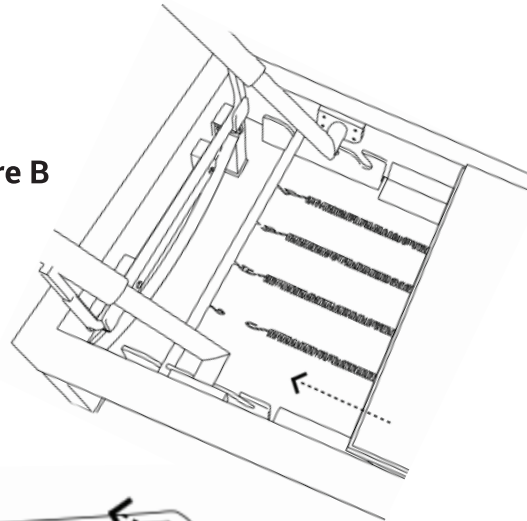

Figure C

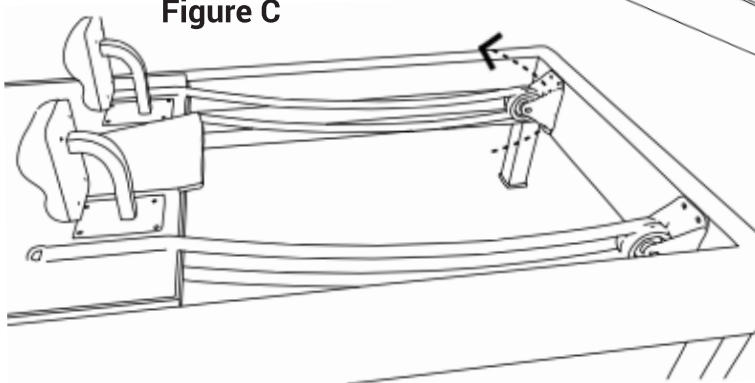
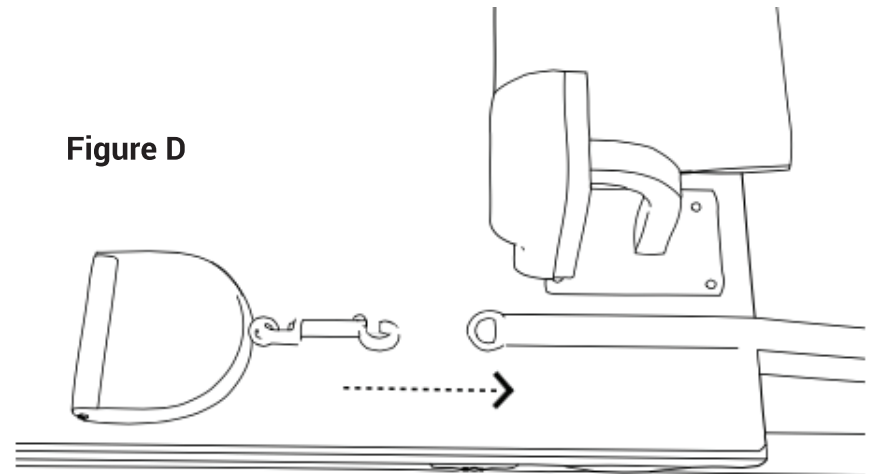

Figure D



IMPORTANT: Two people are required to set up your Universal Reformer. Gratz Industries is not responsible for any damages to the Universal Reformer that is caused by improper set up or installation.

STEP 4 - Prep For Use

Make sure all the springs are in place to your liking and properly attached prior to using.

- Make sure your spring bar is in the gear you want.
- If needed, add the gear blocks to your liking.
- Set up the reformer box to your liking.

Enjoy your Gratz Universal Reformer!

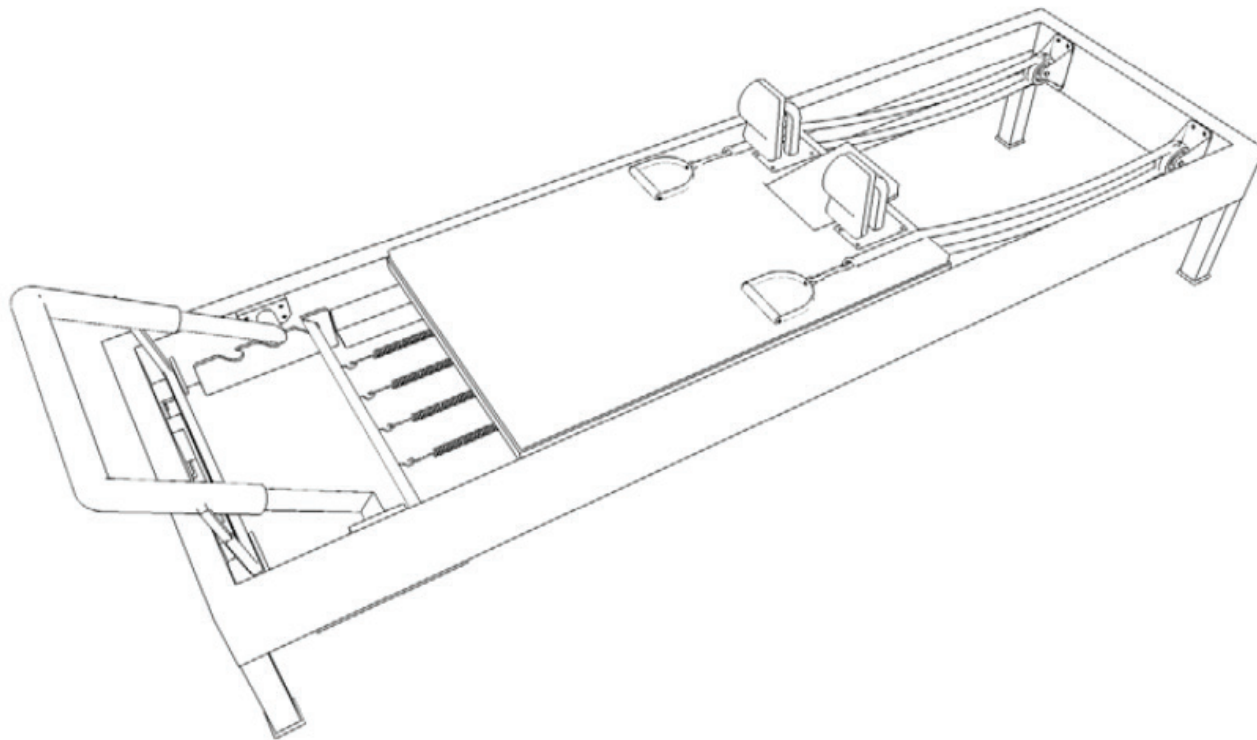

IMPORTANT: Two people are required to set up your Universal Reformer.
Gratz Industries is not responsible for any damages to the Universal Reformer that is caused by improper set up or installation.