

CADILLAC

Assembly Instructions



How to Assemble Your Cadillac

What Comes in the Box

- A.** Cadillac Frame
 - B.** (4) Traveling Pipes (6" for transit only)
 - C1.** (2) Vertical Pipes and (2) **C2.** Vertical Pipes attached to (1) Push Through Bar
 - D1.** Canopy
 - **D2.** (2) Trapeze Slider Tension Knobs
 - **D3.** (4) 3-way Flange
 - E.** Trapeze Assembly including...
 1. Trapeze Bar
 2. Trapeze springs
 3. (2) Double Hooks
 4. (4) Quicklinks
 5. (1) 27" Trapeze Strap
 - F.** Roll Down Bar [including (2) Roll Down Springs and (4) Double Hooks]
 - G.** (2) Leg Springs
 - (2) 9" Foot Loops and 4 Double Hooks
 - H.** (2) Arm Springs [4 Double Hooks]
 - I.** (3) Safety Chains
 - (7) Stow Chain
 - (6) Quicklinks
 - (3) Swivel Hooks
 - J.** (2) Wooden Handles
 - K.** (2) 20" Foot Strap
 - 2 Double Hooks
 - L.** Kuna Board (Spread Eagle)
 - M.** (2) Sheepskin Hanging Loops
 - N.** 90" Webbing Strap
- O.** Allen Key *included
 - P.** (2) 5/16" Eye Bolts (side)
 - Q.** (2) 3/8" Eye Bolts (rear)
 - R.** (2) Trapeze Slider Tension Knobs

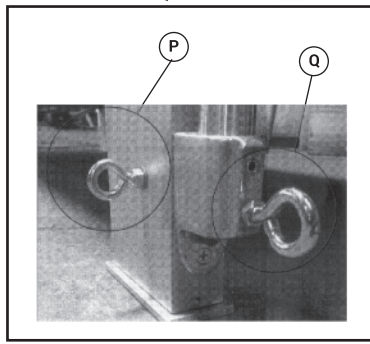
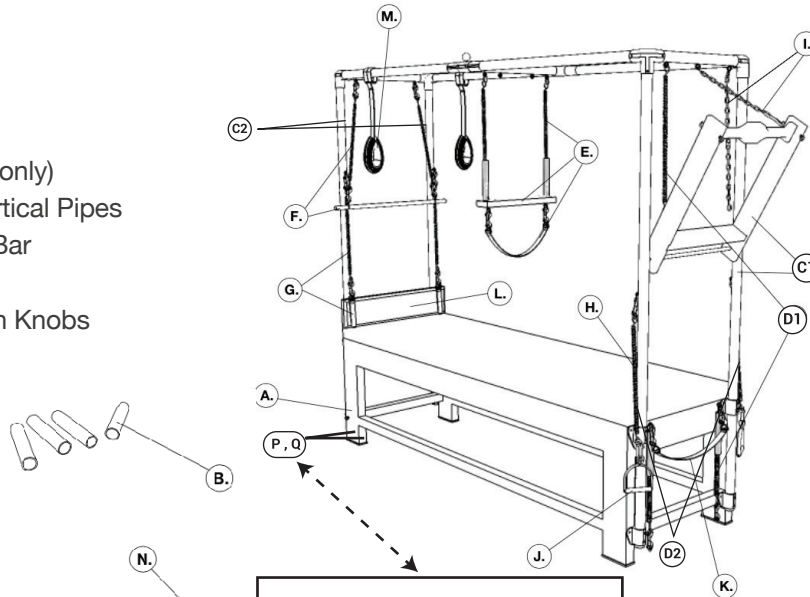

OPTIONAL EYE BOLTS for **Q**
Remove Allen key insert/bolt that is inside the Cadillac before installing.

STEP 1 - Remove Contents from Box

Place the box long side down. Use the scissors carefully to cut ties. Two Packed bundles should be in the box with everything listed on the "What Comes in the Box"

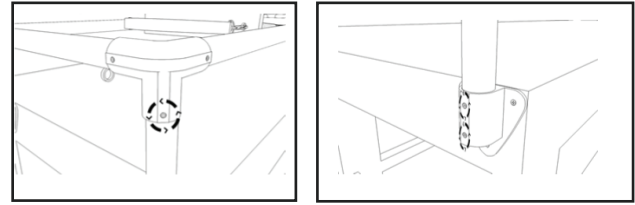

STEP 2 - Remove the Traveling Pipes

Use the Allen key to unscrew the traveling pipes from the Cadillac frame (**Figure A**). Next, use the Allen key to unscrew hex screws in the traveling pipes from the Cadillac frame (**Figure B**). Be sure to hold the travel pipes while unscrewing, so they don't fall through. Then remove the traveling pipes (**Figure C**).

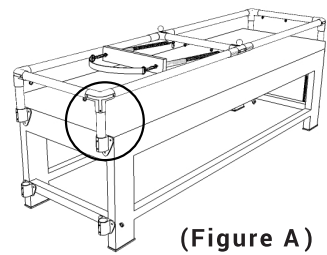

(Figure A)

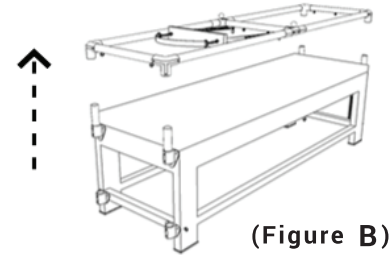

(Figure B)

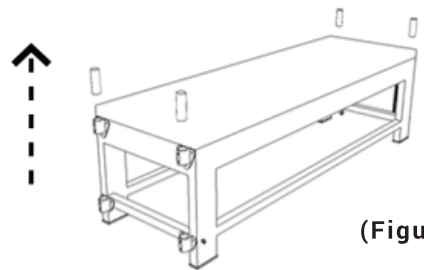

(Figure C)

What You Will Need:

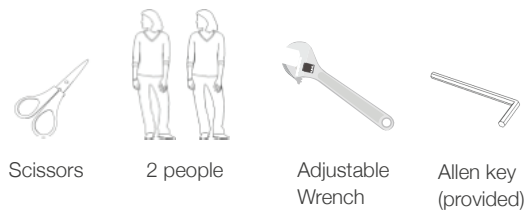

IMPORTANT NOTE: Two people are required to set up your Cadillac.

Gratz Industries is not responsible for any damages to the Cadillac that is caused by improper opening, set up or installation. Please email customercare@gratzindustries.com for any inquiries.

STEP 3 - Place the Vertical Pipes and Canopy on Cadillac

Locate the Allen key and 4 vertical pipes. Loosen the screws and insert the 4 vertical pipes into the flanges on the Cadillac frame (See Figure D). Tighten the screws until the vertical pipes are firmly secure (See Figure E). Carefully place the canopy on the top of the 4 vertical pipes (See Figure F). Carefully tighten the screws until the canopy is firmly secure on top of the vertical pipes (See Figure G).

(Figure D)

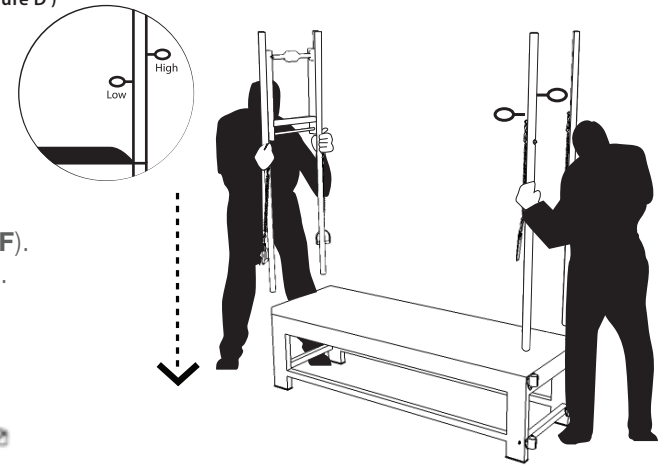

(Figure E)

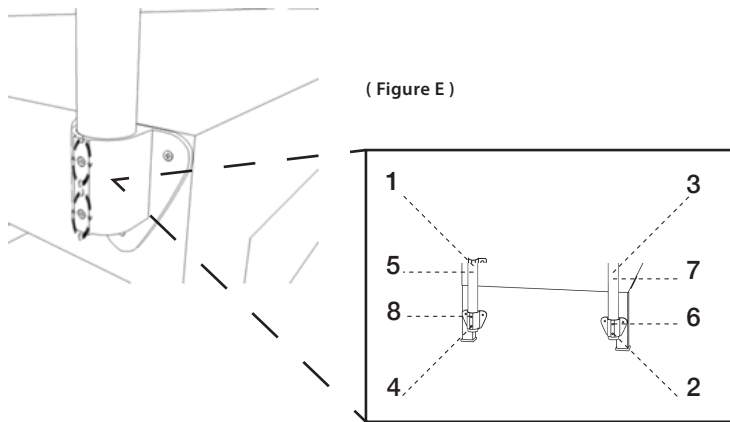

(Figure F)

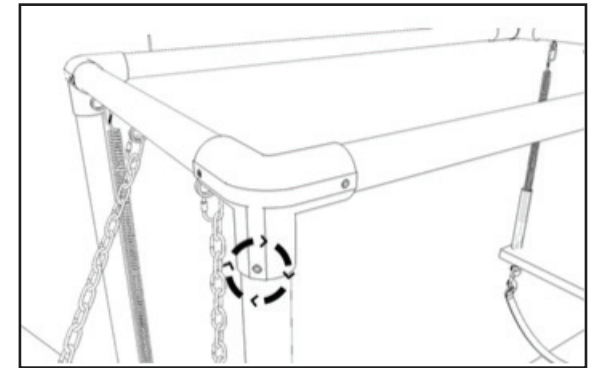
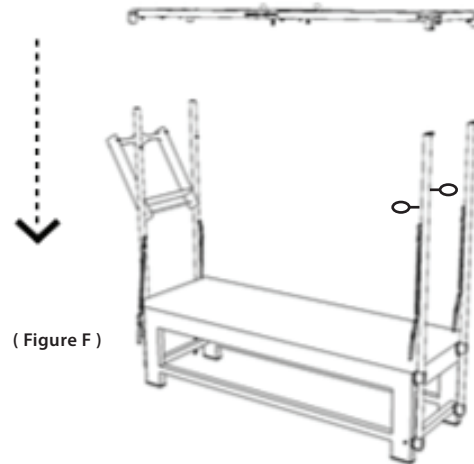

(Figure G)

STEP 4 - Prep for Use

Prior to using, make sure all springs are in place to your liking and are properly attached.

STEP 5 - How to Position your Trapeze Set

To adjust the Trapeze set, twist the 2 black knobs until the top crossbar is loose (Figure H). Then slide the Trapeze set to the position of your liking (Figure I). Tighten the black knobs until the cross bar is firmly in place (Figure J).

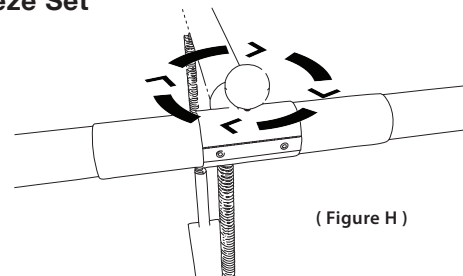

(Figure H)

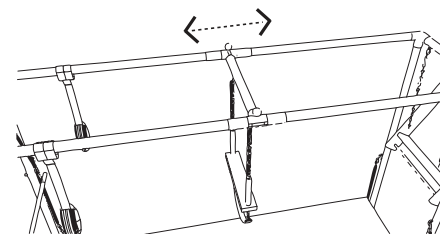

(Figure I)

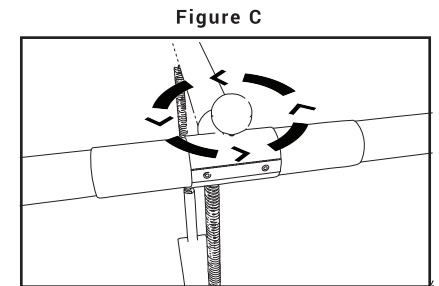

(Figure J)

IMPORTANT NOTE: Two people are required to set up your Cadillac.

Gratz Industries is not responsible for any damages to the Cadillac that is caused by improper opening, set up or installation. Please email customer@gratzindustries.com for any inquiries.

RECOMMENDED USE AND SAFETY

Gratz recommends consulting a physician before starting any exercise program. This manual contains important assembly, safety, and warranty information. Please read carefully before using your new equipment. **USER ASSUMES ALL RISKS FOR IMPROPER CARE.**

It is impossible to anticipate every potential issue that may arise while using this equipment, so Gratz makes no representation concerning the safety of this equipment. For inexperienced or first-time users, we recommend this equipment be set up under the supervision of a trained professional. Contact customercare@gratzindustries.com or Pilates Pro Maintenance for assistance: service@pilatespromaintenance.com



CAUTION

Misuse or improper use of this equipment due to failure to read and comply with all requirements and warnings could result in serious injury.

- USE ONLY PARTS AND ACCESSORIES PROVIDED BY THE MANUFACTURER. DO NOT USE COMPONENTS NOT APPROVED BY GRATZ PILATES.
- MAKE CERTAIN THAT THE EQUIPMENT IS OPERATED ON A LEVEL SURFACE. KEEP AT LEAST 18IN OF SPACE BETWEEN EQUIPMENT.
- BE SURE THAT ALL PARTS ARE FULLY TIGHTENED BEFORE BEGINNING ANY EXERCISE.
- INSPECT THAT THE SPRINGS HAVE NO DEFECTS SUCH AS CRACKS. IMMEDIATELY REQUEST REPLACEMENT IF YOU SEE ANY DAMAGES.
- CONFIRM THAT NO TEARS ARE PRESENT IN THE VINYL LEATHER STRAPS OR HANDLES. IMMEDIATELY REQUEST REPLACEMENT IF NOTICED.
- USERS UNDER 18 SHOULD HAVE ADULT SUPERVISION.
- KEEP ANY LOOSE ITEMS OR CLOTHES CLEAR FROM MOVING PARTS AT ALL TIME.

- IT IS THE BUYER'S RESPONSIBILITY TO SUPERVISE OTHER USERS ON THE PROPER CARE AND USE OF THE EQUIPMENT. GRATZ STRONGLY RECOMMENDS THAT NEW USERS BE PROPERLY EVALUATED BEFORE USING GRATZ EQUIPMENT.

WARNING: As with any exercise activity, the use of equipment involves risk of injury, damage and/or possibly death.

By choosing to use Gratz equipment, you and/or your clients/patients/others assume responsibility for that risk, not the people who sell, distribute and/or manufacture this equipment.

Visit www.pilates-gratz.com to find complete warranty, maintenance, and other assembly instructions.