



Item # 1001 024 909

Model # SP-K-609/3

USE AND CARE GUIDE

St. Lucia 3 Piece Padded Motion Bistro Set

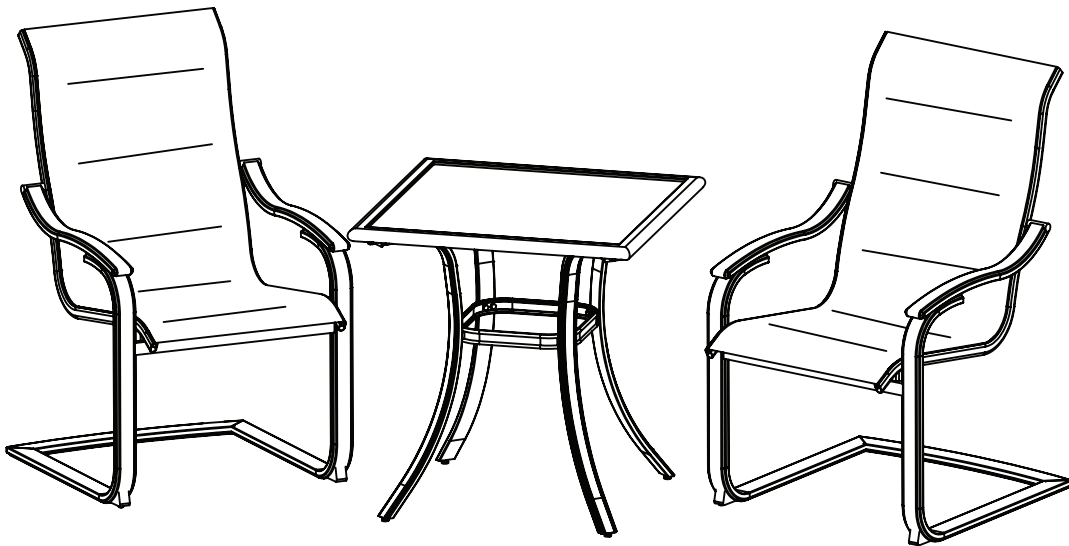

SP-K-609N-1

SP-K-609CT

Questions, problems, missing parts? Before returning to the store,
call Hampton Bay Customer Service
8 a.m. - 6 p.m., EST, Monday - Friday 9 a.m - 6 p.m., EST, Saturday

1-855-HD-HAMPTON

HOMEDEPOT.CA

THANK YOU

*We appreciate the trust and confidence you have placed in Hampton Bay through the purchase of this dining set. We strive to continually create quality products designed to enhance your home. Visit us online to see our full line of products available for your home improvement needs.
Thank you for choosing Hampton Bay!*

Table of Contents

Table of Contents	2	Pre-Installation	3
Safety Information	2	Planning Installation	3 & 4
Warranty	2	Chair Installation	4 & 5
What is covered	2	Table Installation	5 & 6
What is not covered	2	Care & Maintenance	6
		Service Parts	7

Important Safety Instructions

SAVE THESE INSTRUCTIONS

READ ALL INSTRUCTIONS BEFORE USING

To reduce the risk of injury to persons:

1. Close supervision is necessary when this furnishing is used by or near children, or disabled persons, if applicable.
2. Use this furnishing only for its intended use as described in these instructions. Do not use attachments not recommended by the manufacturer.
3. Do not move the chaise lounge chair while it is occupied. Failure to obey this caution could result in injury.
4. This table is not intended to support an umbrella. Umbrellas must have a suitable base or stand.



WARNING: Keep children away during assembly.



WARNING: The recommended weight limit is 225lbs.



CAUTION: If you overload your furniture, injuries can occur.



IMPORTANT: Check all nuts and bolts for tightness before and during usage season.



IMPORTANT: Always use an umbrella base with your umbrella.

Warranty

WHAT IS COVERED

We warrant our products to be free of manufacturing defects to the original purchaser for the period listed below. We reserve the right to make substitutions with similar merchandise, if the model in question is no longer in production.

WHAT IS NOT COVERED

This warranty does not cover: Furniture used for commercial or non-residential purposes; failures caused by improper care; unreasonable or abusive use; freeze damage; acts of nature. Steel products are not covered against rust. Ceramic tile table tops are not covered against breakage.

Contact the Customer Service Team at 1-855-HD-HAMPTON or visit WWW.HOMEDEPOT.CA

Pre-Installation

PLANNING INSTALLATION

Read through all the instructions before beginning assembly. Unpack and identify all the parts. Place them on a flat, non-abrasive surface. Assembly by two people is recommended.

TOOLS REQUIRED (NOT INCLUDED)

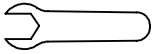

1/4 in. Hex wrench

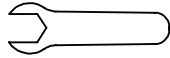

5/16 in. Hex wrench

HARDWARE INCLUDED



NOTE: Hardware not shown to actual size.

NO.	Description	Quantity	Part
AA	1/4 * 5/8 in. bolt	1 spare	
BB	1/4 * 2-1/2 in. bolt	4	
CC	5/16 * 1-1/2 in. bolt	4	
DD	1/4 in. metal washer	8	
EE	5/16 in. metal washer	4	
FF	1/4 in. nut	4	
GG	5/16 in. lock washer	4	

Pre-Installation(Continued)

PACKAGE CONTENTS

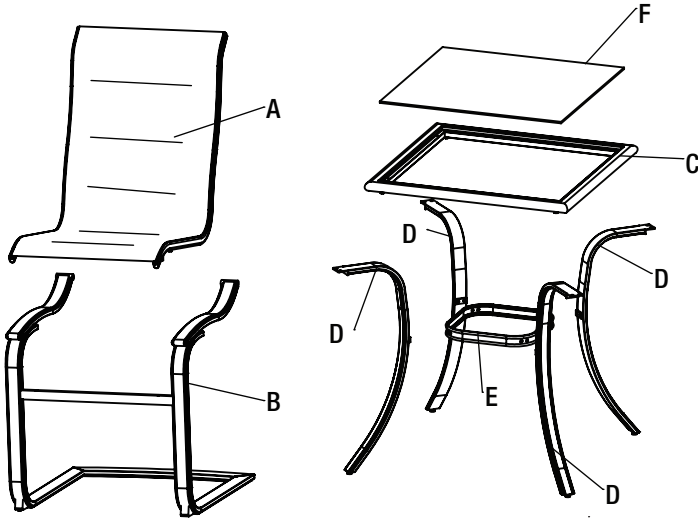

Part	Description	Quantity
A	Chair seat and back	2
B	Chair base	2
C	Table rim	1
D	Table leg	4
E	Metal center ring	1
F	Glass top	1

Chair Assembly



NOTE: Do not completely tighten bolts until indicated in assembly step.

1 Attaching the chair seat and back to the chair base

- Attach the seat and back (A) to the chair frame (B) using a 1/4 * 2-1/2 in. bolt (BB) through a 1/4 in. Metal Washer (DD), through the chair frame (B) and the seat and back (A), through a 1/4 in. Metal Washer (DD) and secure with a 1/4 in. Nut (FF). Repeat procedure for the other side.

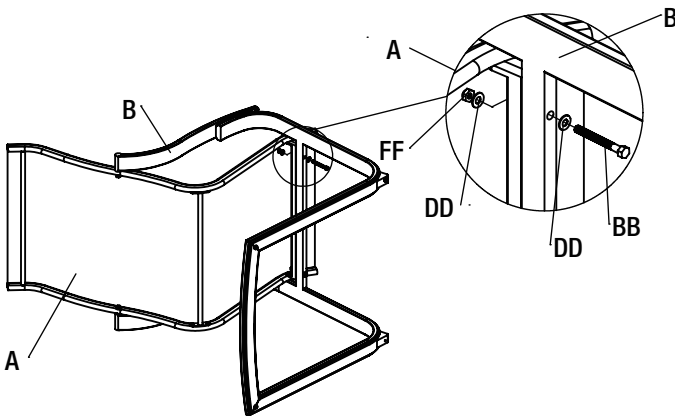

2 Attaching the chair seat and back to the chair base

- Insert a 5/16 * 1-1/2 in. Bolt (CC) through a 5/16 in. lock washer (GG) and a 5/16 in. Metal Washer (EE), through the seat and back (A) and secure into the chair frame (B). Repeat procedure for the other side.

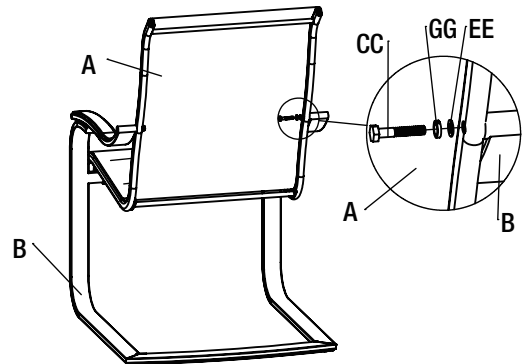

Securely tighten all bolts and nuts.

Chair Assembly (Continued)

3 Turning the chair upright

- Turn the chair upright. Repeat procedure for other chair. Your chairs are now ready for use.

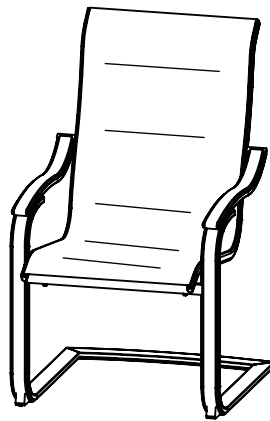

Bistro Table Assembly



NOTE: Do not completely tighten bolts until indicated in assembly step.

4 Attaching the table leg to the table rim

- Remove all 1/4 * 5/8 in. bolts (AA) and 1/4 in. metal washers (DD) from the table rim (C). Attach the table leg (D) to the table rim (C) using two 1/4 * 5/8 in. bolts (AA) through two 1/4 in. metal washers (DD) into the table leg (D) and table rim (C). Repeat procedure for the other three legs.

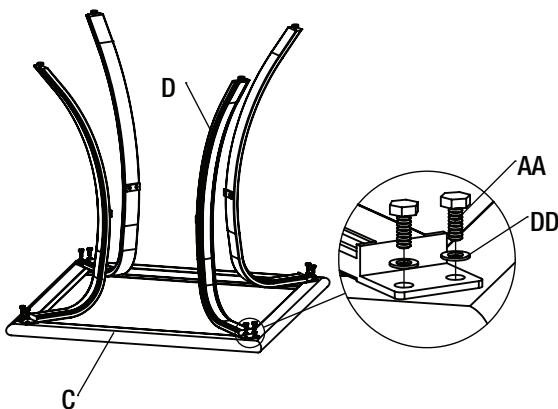

5 Attaching the metal center ring to the table legs

- Remove all 1/4 * 5/8 in. bolts (AA) and 1/4 in. metal washers (DD) from the table legs (D). Attach the metal center ring (E) to the table legs (D) using two 1/4 * 5/8 in. bolts (AA) through two 1/4 in. metal washers (DD) into the metal center ring (E) and table leg (D). Repeat procedure for the other three legs.

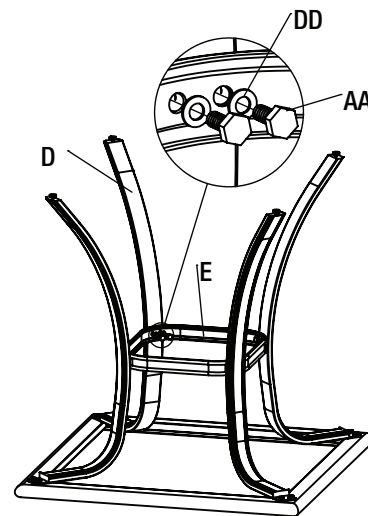

Bistro Table Assembly (Continued)

6 Putting the glass(F) onto the table rim

- Turn the table upright and tighten all the bolts diagonally. Then put the glass top (F) onto the table.

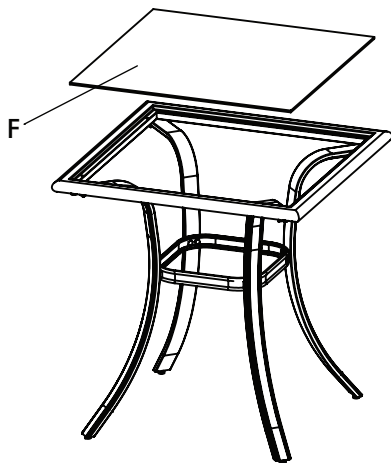

Your bistro set is now ready for use.

Care and Maintenance

Though its powder-coated finish is rust-resistant, steel is prone to rust over time with exposure to the elements. In case of rust or scratches, lightly sand the affected area and apply touch-up paint. To maintain the finish periodically apply wax with a soft cloth. Wash frames with a mild solution of soap and water; rinse thoroughly. Do not use bleach or solvents. Do not store anything on glass tabletop. Use furniture covers or store indoors during cold or inclement weather.



Questions, problems, missing parts? Before returning to the store,
call Hampton Bay Customer Service
8 a.m. – 7 p.m., EST, Monday – Friday, 9 a.m. – 6 p.m., EST, Saturday

1-855-HD-HAMPTON

HOMEDEPOT.CA

Retain this manual for future use.