



# CROSS BACK 3 PC METAL SET

## Instruction Manual

SKU# 1425363

Please read instructions carefully before use. Retain for future reference

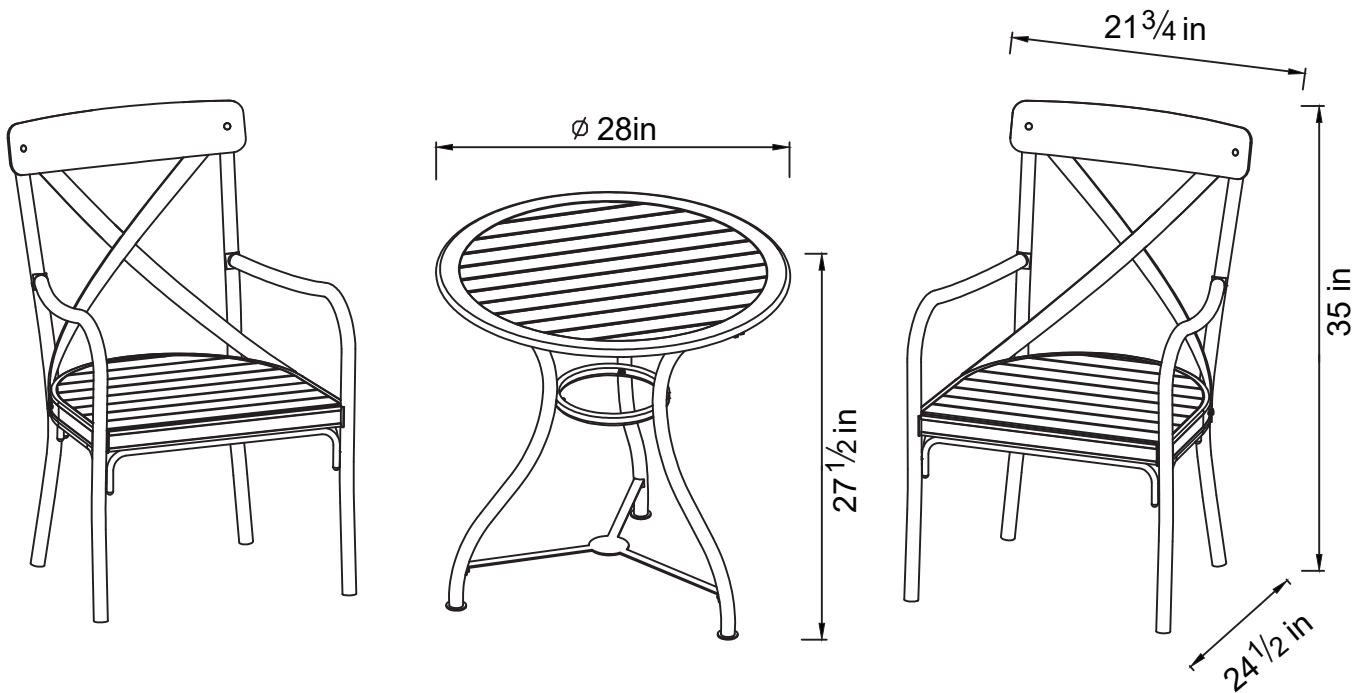

### Assembled Dimensions

Distributed by:  
 TRACTOR SUPPLY COMPANY  
 5401 VIRGINIA WAY,  
 BRENTWOOD TN 37027  
 For customer support,  
 call: 1-888-376-9601  
[www.TractorSupply.com](http://www.TractorSupply.com)  
 MADE IN CHINA

Approximate assembly time: <b>30 Minutes</b>	People for assembly:	Required assembly space: Floor area 9 ft. x 9 ft. (3 m x 3 m)
--	----------------------	---

Required assembly tools (included):

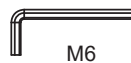

Required assembly tools (not included):





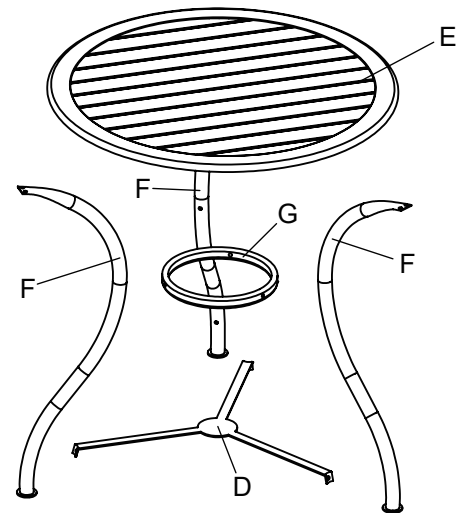
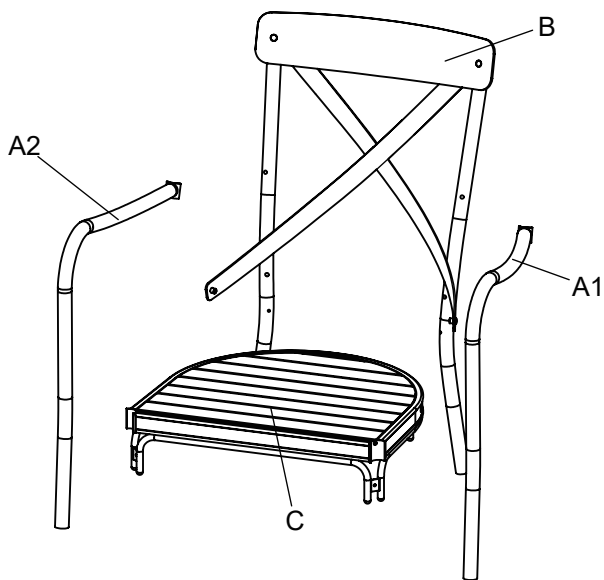

**CAUTION:**  
 Hand tools only, use of power tools could damage product.

## PART LIST

No.	Description	Quantity	No.	Description	Quantity
A1	left arm	2	E	table top (attached with 6pc bolts and 6pc washers)	1
A2	right arm	2	F	table leg (attached with 1pc bolt and 1pc washer for each)	3
B	chair back	2	G	top metal center ring	1
C	chair seat	2	D	bottom metal center ring	1



## HARDWARE LIST

H1	4 sets + 1 spare set Short bolt		H3	4 sets + 1 spare set Long bolt	
H2	12 sets + 1 spare set Medium bolt		H4	3 sets + 1 spare set Screw	

## **TIP BEFORE YOU START**

---

- \* Ensure that all parts are present prior to assembly.
- \* Check all packing material carefully before discarding, as some parts may be encased in the packing material.
- \* For ease and speed of assembly, it is recommended that prior to each step all required parts are identified.
- \* Ensure that you have sufficient space and people (as indicated on page 1) to assemble product safely.
- \* During assembly take care not to over-tighten any fittings, as this may damage the product.

## **CARE AND MAINTENANCE**

---

- \* Always inspect the product during each use for any obstructions.
- \* The manufacturer will not accept responsibility for unauthorized repairs or modifications to this product.
- \* To clean, wash frame with mild soap and water; rinse thoroughly. Dry frame completely.
- \* Do not use bleach, acid, or other solvents on the frame parts.
- \* To prolong the life of your furniture we recommend storage in a dry area when not in use or during austere weather conditions.



## **WARNING**

---

- \* Annually:
  - \* Check all nuts and bolts for tightness each season and more often if used frequently.
  - \* Oil all metal moving parts with a general purpose lubricating oil to ensure proper performance and safety.
- \* Keep children away during assembly. This item contains small parts which can be swallowed by children. Children should always be under adult supervision while using this product.
- \* This product is for residential use only, not for commercial use.

## **WEIGHT LIMIT**

---

Chair: 225lb. (102kg)

# ASSEMBLY INSTRUCTIONS

1

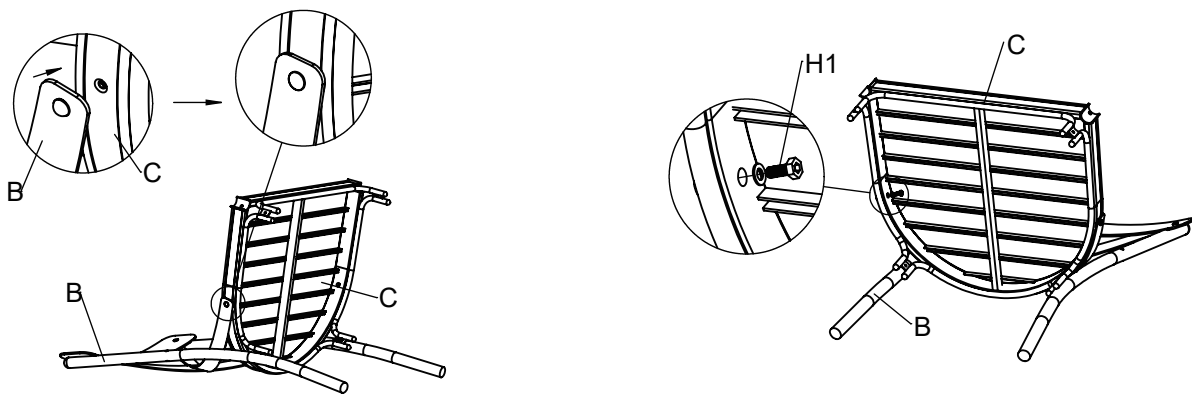

Do not tighten completely. Repeat procedure for the other side.

H1	2 sets Short bolt		 M6
----	----------------------	---	---

2

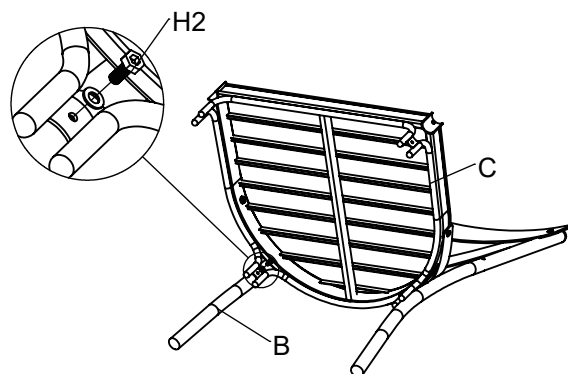

Do not tighten completely. Repeat procedure for the other side.

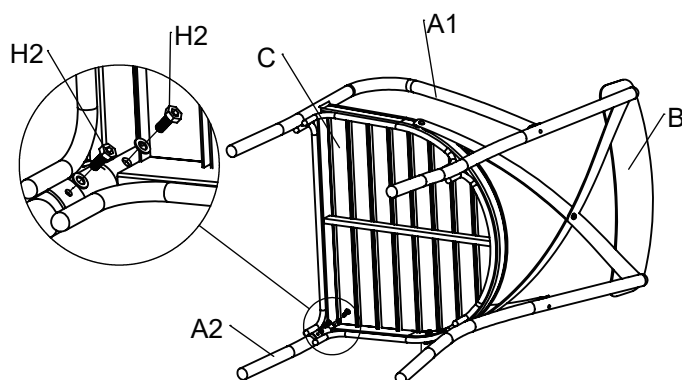

H2	2 sets Medium bolt		 M6
----	-----------------------	---	---

3



**SIDE**

Do not tighten completely. Repeat procedure for the other side.

H2	4 sets Medium bolt		 M6
----	-----------------------	---	---

# ASSEMBLY INSTRUCTIONS

4

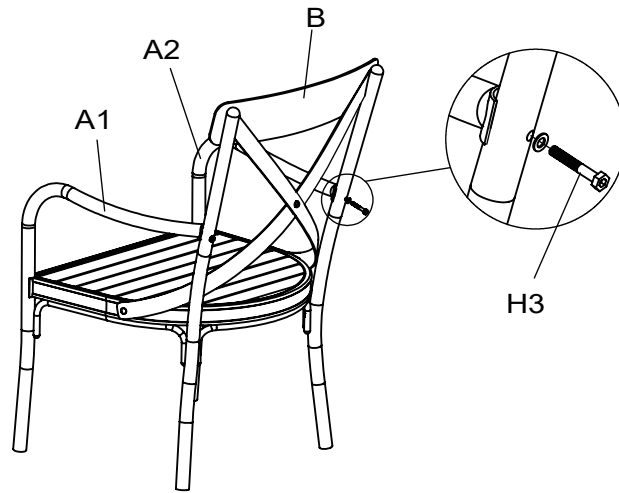

Securely tighten all bolts. Repeat procedure for the other chair.

H3	2 sets Long bolt		 M6
----	---------------------	---	--

5

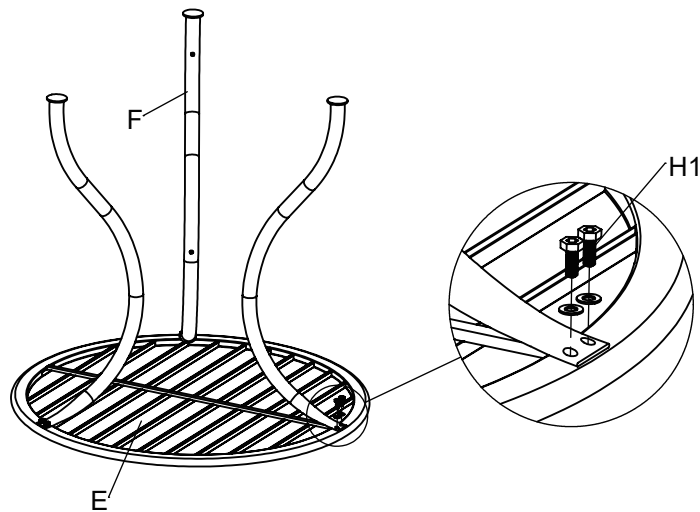

Do not tighten completely. Repeat procedure for the other two legs.

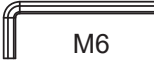

H1	6 sets (remove from the tabletop) Short bolt		 M6
----	---	---	--

# ASSEMBLY INSTRUCTIONS

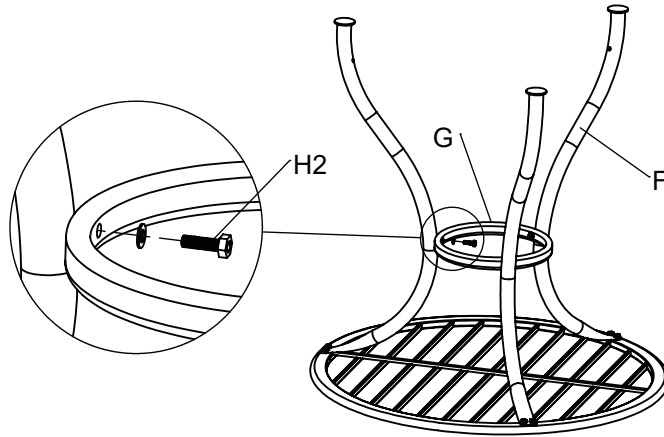
6



Do not tighten completely. Repeat procedure for the other two legs.

H2	3 sets (remove from the legs) Medium bolt		 M6
----	--	---	---

7

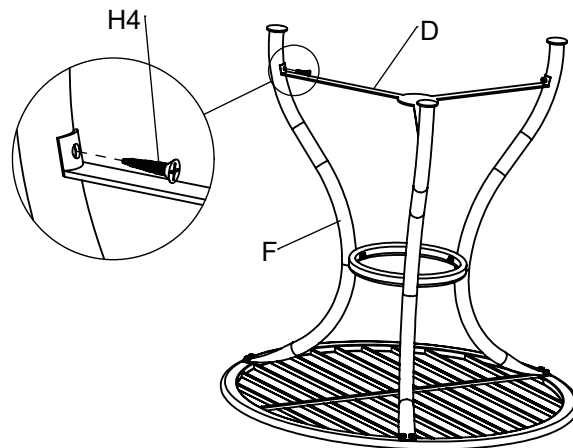

Securely tighten all bolts.

H4	3 sets Screw		
----	-----------------	---	--