

stoZm ADJUSTABLE BARBELL RACK

Read all assembly and care instructions carefully before using this product. Save these instructions for future reference.

- Select a smooth, level surface to place the barbell rack's parts.
- Assemble components on a soft, clean surface to avoid scratching and/or damaging the finish.
- Assemble the item as close to its final position (in the same room) as possible.
- Ensure all parts are accounted for before disposing of packaging.
- This package contains small parts. Keep away from children & pets at all times. Adult assembly required. Screws left after assembly should be kept out of reach of children.
- Consult your physician before starting your exercise program. For your own safety, do not begin any exercise program without proper instruction.
- If the user experiences dizziness, nausea, chest pain, or other abnormal symptoms stop the workout and seek immediate help

IMPORTANT INFORMATION

Under normal use, STOZM Barbell Rack will last for years. It is, however, important to follow basic care tips to prolong the life of your Barbell Rack.

USE & CARE

- ▶ Please do not exceed the weight limit of this item.
- ▶ Do not stand on or use any part of this item as a step ladder.
- ▶ Keep clear of cables and all moving parts when the machine is in use.
- ▶ Inspect and tighten all parts before using this item.
- ▶ Reconfirm that all bolts, screws and knobs are secured after every 30 days.
- ▶ Fasten screws loosely during initial assembly. Do not firmly tighten the screws until the item is completely assembled.
- ▶ Safety: To increase safety and stability, please use the corresponding wrench to tighten the nuts. You cannot tighten the nuts by hand only.
- ▶ Be aware that some parts are heavy and have sharp edges.
- ▶ If any parts are missing, broken, damaged or worn, stop using this product until repairs are made and/or factory replacement parts are installed.
- ▶ The equipment can be cleaned using a damp cloth and mild non-abrasive detergent. Do not use solvents.

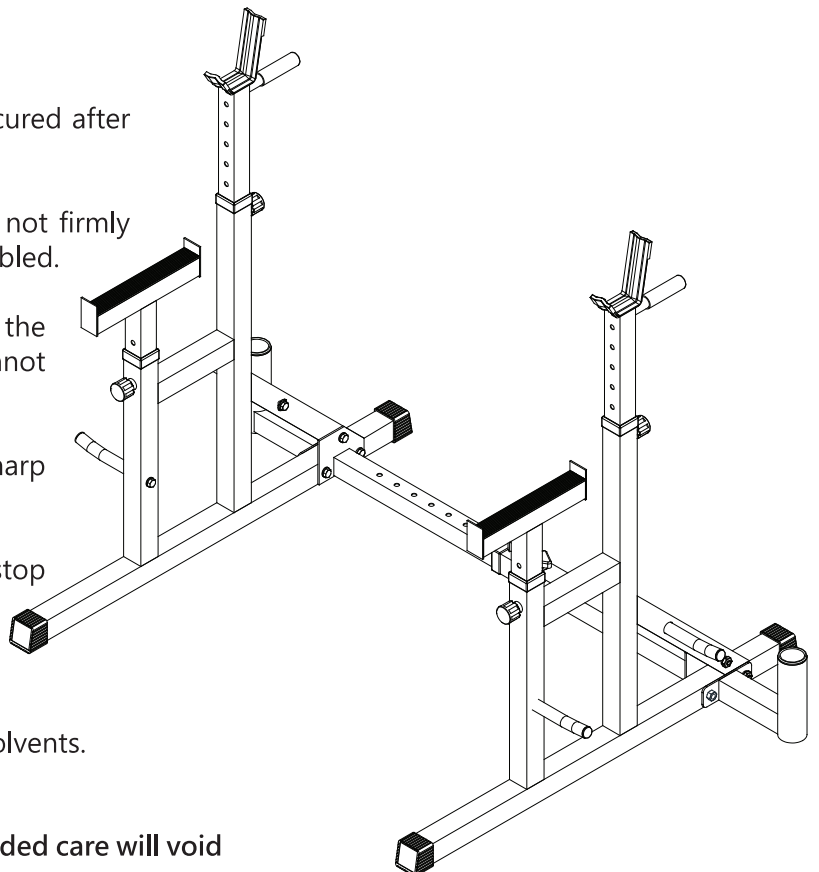

Any modification or failure to follow the recommended care will void the product warranty.

WARRANTY INFORMATION

Thank you for choosing STOZM. We stand behind our brand and the quality of the items we sell.

The Barbell Rack comes with a 1-year limited manufacturing warranty that covers defects in material and workmanship, missing delivery parts or missing hardware, and scratches from shipping. The warranty does not cover normal wear and tear, for products used commercially or for failures caused by accidents, abuse, alteration, modification, misuse or improper care. There are no other express warranties beyond the terms of this limited warranty. In no event shall any implied warranties, including merchantability and fitness for a particular purpose, extend beyond the duration of the express warranty contained herein. In no event shall STOZM be liable for incidental or consequential damages.

All products are carefully inspected prior to shipment. Please carefully inspect your barbell rack at the time of delivery. Replacement parts or products will be sent at our discretion if the defect is the result of any fault on our side. Proof of purchase, with the date of purchase as well as photos of the defective merchandise, must be provided. Photos are used to determine the cause of defects and for future quality control.

If you notice anything out of the ordinary, please contact STOZM Customer Service directly; or if you have any questions, comments or concerns, you can email us at: customerservice@stozm.com, or via our Contact Us page at www.stozm.com/contact-us

ASSEMBLY

Note: The Barbell Rack should be assembled by two adults. If you assemble the Barbell Rack alone, be careful when lifting heavy parts. Ensure the assembly area is larger than the Barbell Rack. Follow the steps carefully to assemble the Barbell Rack correctly.

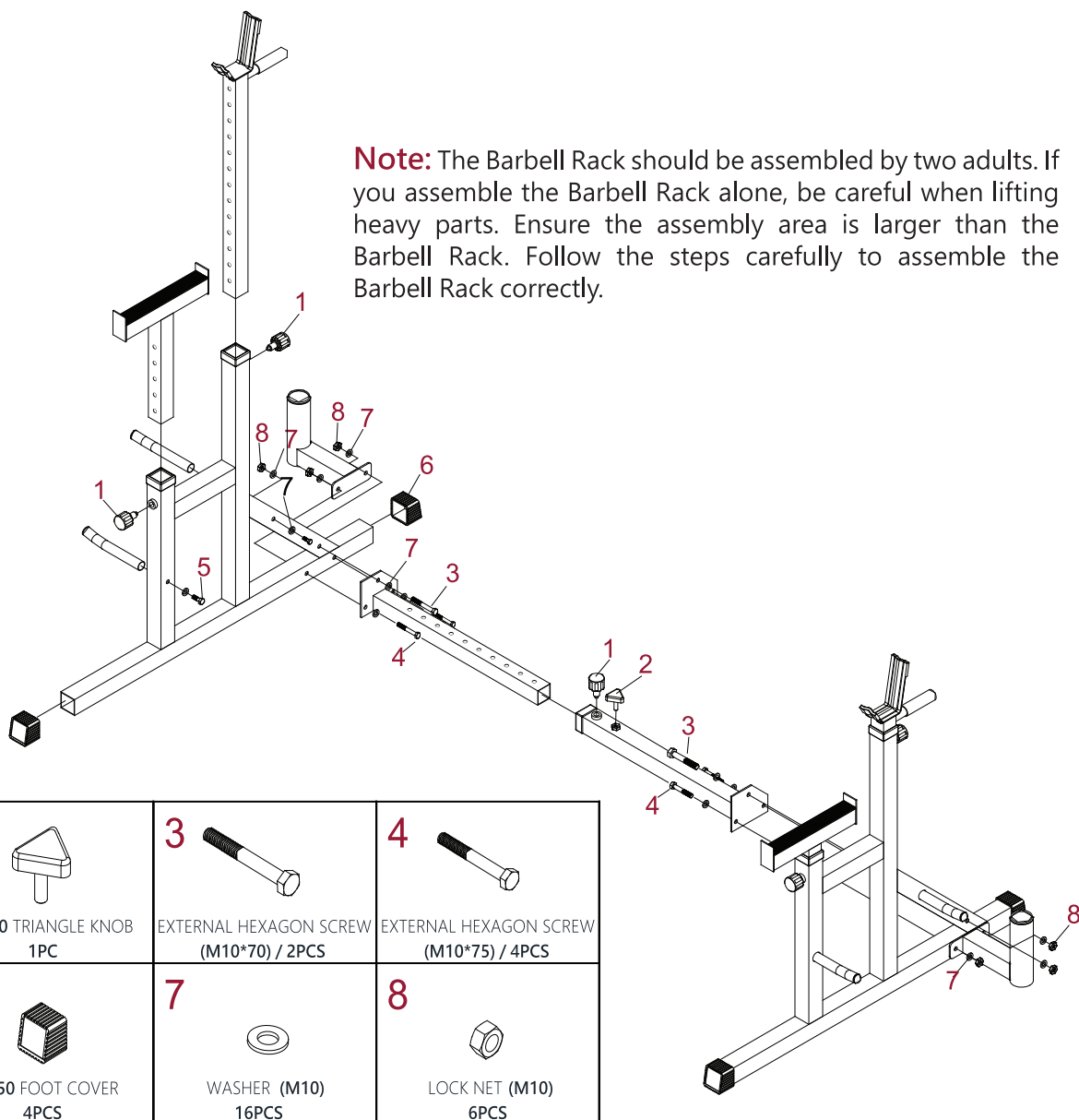

WARNING

Manufacturer and seller expressly disclaim any and all liability from personal injury, property damage or loss, whether direct or indirect, or incidental, resulting from the incorrect attachment, improper use, inadequate maintenance, neglect of this product or disasters, external influence, and force majeure.