

# EaganMatrix User Guide

October 23, 2022

Firmware Version 10.x

The screenshot displays the EaganMatrix software interface, which is divided into several functional sections:

- Control 1:** A vertical sidebar on the left with colored buttons for C1 (blue), C2 (red), C3 (green), and other controls.
- Macro Controllers:** A row of six sliders labeled i (Breath), ii (Body (p2)), iii (Conv-4), iv (Low), v (Overtone), and vi (Tone). Each slider has a numerical value and a range indicator.
- Recirculator Reverb:** A section with sliders for Diffuse (R1), Darkness (R2), Damping (R3), Short Decay (R4), and Blend (Mix). It also includes buttons for 'Extend' and 'Reverb'.
- Pedal 1 & 2:** Two sections for 'Pedal 1: Sus' and 'Pedal 2: ii', each with a slider and a 'Max' button.
- Other Parameters:** Includes 'Polyphony: Base 1', 'Rounding: Normal', 'Mono Mode: Portamento', and 'Oct Switch: Switch'.
- System Library:** A row of buttons for 'System Library' and 'EaganMatrix'.
- Matrix Grid:** A large grid with columns labeled 'Master', '1HP', 'Osc', '1HP', '1LP', 'LP', 'BiqGraph 1', 'BiqBank 2', and 'MicroDelay'. The grid contains various colored cells and letters (A, B, C, D, E, F, G, H, J, K, L, M, S, U, V, X, Y, Z) representing different control states or formulas.
- Formula Display:** A list of formulas on the right side, such as 'A: 1 x X Y Z', 'B: W x X Y Z', etc.
- Control Text:** A text area at the bottom left with the text: 'i=Breath Ob ii=Body\_Conv-1\_Conv-2\_Conv-3\_Conv-4 iii=Overtone\_High\_Low iv=Tone\_Ob C=W FL CN BH\_DM\_OS\_PO\_SV A=C.Duquesne'.

Edmund Eagan, Lippold Haken, Richard Kram

<b>1.</b>	<b>Introduction to the EaganMatrix</b>	<b>4</b>
	<hr/>	
1.1.	EaganMatrix Math	5
1.2.	Modules	6
1.3.	Source and Destination Locations in the Editor	8
1.4.	New Haken Editor / EaganMatrix User Experience (Post Version 9.55)	9
<b>2.</b>	<b>Basic Design Concepts</b>	<b>15</b>
	<hr/>	
2.1.	The Matrix in the EaganMatrix	15
2.2.	Playing Surface to Formula Connection	16
2.3.	Formula Creation Basics	18
2.4.	WXYZ - The Four Components of an EaganMatrix Formula	20
<b>3.</b>	<b>Exploring the EaganMatrix</b>	<b>22</b>
<b>4.</b>	<b>Tutorials</b>	<b>23</b>
	<hr/>	
4.1.	Tutorial 1: Simple FM	23
4.2.	Tutorial 2: Resonant Drum	29
<b>5.</b>	<b>EaganMatrix Sources Reference</b>	<b>32</b>
	<hr/>	
5.1.	Sources	32
5.2.	Direct Sources	33
<b>6.</b>	<b>EaganMatrix Destinations Reference</b>	<b>34</b>

---

6.1.	Master	34
6.2.	Oscillators / Filters / Multipliers	36
6.3.	Multipurpose Banks: BiqBank (Modal Physical Model)	50
6.4.	Multipurpose Banks: BiqGraph (Modal Graphs)	55
6.5.	Multipurpose Banks: BiqMouth (Vocal Formants)	59
6.6.	Multipurpose Banks: SineBank (Sine Oscillators)	61
6.7.	Multipurpose Banks: SineSpray (Sine Grains)	66
6.8.	Multipurpose Banks: WaveBank (Waveform Cluster)	66
6.9.	Multipurpose Banks: HarMan (Granular Harmonic Manipulator)	69
6.10.	Multipurpose Banks: ModMan (Modal Manipulator)	71
6.11.	Multipurpose Banks: Additive (Additive Synthesis)	73
6.12.	Multipurpose Banks: Kinetic (Kinetic Physical Model)	74
6.13.	Multipurpose Banks: CVC Control Voltages (Continuum Voltage Converter)	77
6.14.	Multipurpose Banks: VoiceDelay (Audio Delay Buffer, each voice separate)	80
6.15.	Multipurpose Banks: SummedDelay (Audio Delay Buffer, shared by all voices)	81
6.16.	Multipurpose Banks: MicroDelay (Waveguide Physical Model)	82
6.17.	Multipurpose Banks: FormulaDelay (Control Information Delay Buffer)	83
6.18.	Shape Generators	84

**7. EaganMatrix Formula Reference 89**

---

7.1.	W Component of the Formula	89
7.2.	X Component of the Formula	91
7.3.	Y Component of the Formula	93
7.4.	Z Component of the Formula	95
7.5.	Other Parts of the Formula	97
7.6.	Ancillary Operator Mechanism (Primary and Secondary Ancillary Functions)	98
7.7.	Pre-defined Formulas	106
7.8.	Constant Formulas	108
7.9.	Blend Formula Usage	109
7.10.	The Touch Area	114
7.11.	Show Formula (Formula Display for Preset Debugging)	117

**8. Sound Design with the EaganMatrix 118**

---

8.1.	Editing the Selected Matrix Point	118
8.2.	Three and Four-digit Constants in the Matrix	120
8.3.	Master Section (Output Section of the EaganMatrix)	120
8.4.	“Reduce Gain” Message	127
8.5.	“Reduce Polyphony” Message	127
8.6.	Save your Work	128

**9. Need more information? 129**

## 1. Introduction to the EaganMatrix

EaganMatrix is the modular digital synthesizer built into the Continuum Fingerboard and the ContinuuMini. The Continuum Editor program (for Mac and PC) provides the user interface for the EaganMatrix.

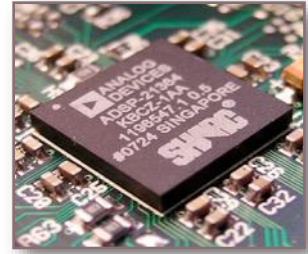

The EaganMatrix allows the user to finely craft musical sound algorithms by connecting audio and control modules via a two dimensional patching matrix. This matrix is inspired by classical modular matrix patching synthesizers such as the EMS VCS3. However, unlike the analog predecessors, the EaganMatrix doesn't use pins to make patch point connections. Instead, the user defines dynamic formulas and places them at matrix patch points. These formulas are a function of the position and pressure of each finger on the playing surface, Shape Generators, and also other formulas. When a formula is assigned to a patch point in the matrix, the formula controls the flow of sound from the source module on the matrix row to the destination module on the matrix column. Each three dimensional performance direction of the Continuum playing surface can influence the final result of every single patch point. And there are many patch points!

This relatively simple concept is powerful. It harnesses the amazing performance response of the Continuum Fingerboard so that the performer can create nuanced, expressive, dynamic, and totally custom sounds. Sounds tailored specifically to your personal musical tastes and even specific performance techniques.

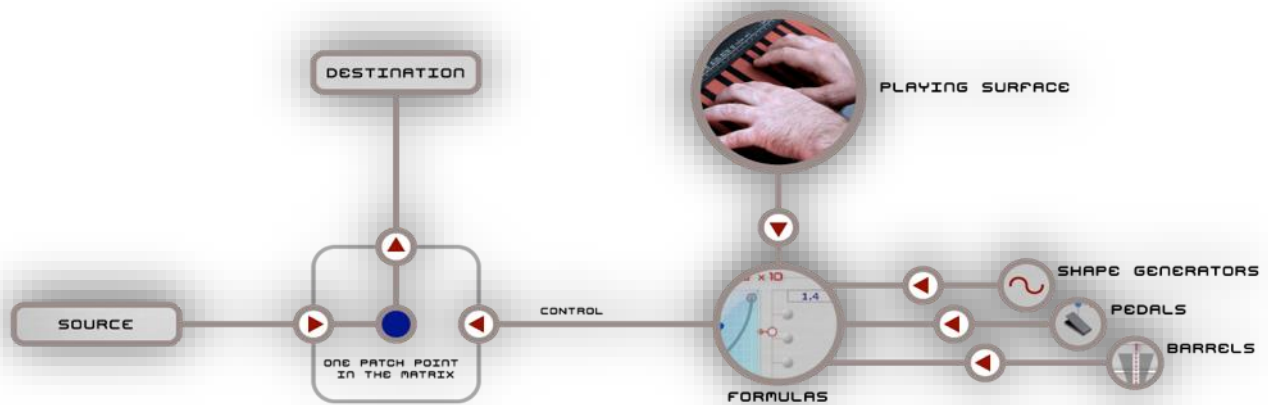

## 1.1. EaganMatrix Math

The EaganMatrix requires the sound designer to think in a particular mathematical way that is somewhat different from traditional hardware and software synthesizers. However, only a basic knowledge of math is required, though the fingerboard centric formulas that drive EaganMatrix programming can interact in a multitude of ways. Below is an extracted part from an EaganMatrix formula:

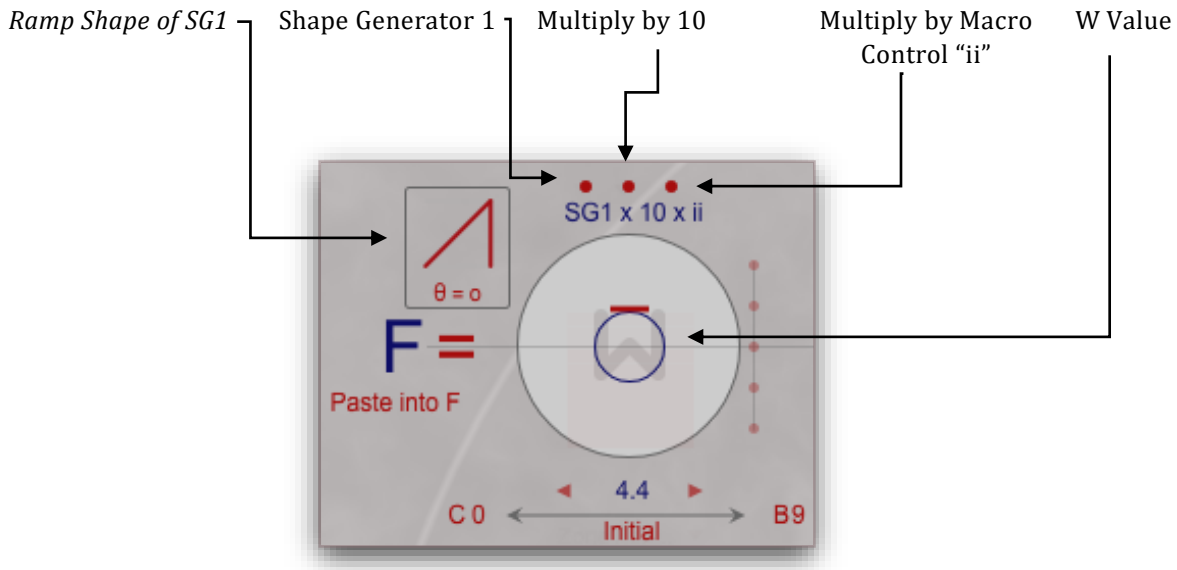

*An example of the math in the W component of an EaganMatrix formula:  
Ramp from 0 to 1 (Shape Generator 1) x 4.4 (W Slider) x10 x value of Control "ii"*

This potentially complex mathematical language of the EaganMatrix has been simplified and distilled to best exploit the performance capabilities of the Continuum Fingerboard. The EaganMatrix already includes a comprehensive selection of predefined System Presets that can be further tweaked, aiding in the early exploration of the EaganMatrix design structure. As the sound designer masters this EaganMatrix math, its new capabilities will allow creation of musically satisfying relationships between fingers on the playing surface and the sounds produced, relationships that truly rival the warmth and complexity of acoustic instruments.

## 1.2. Modules

The following modules are available in the EaganMatrix, acting as matrix sources (Src), matrix destinations (Dst), or both sources and destinations (though not all are available simultaneously):

Src	Dst	Description
•		A wide-band (white) noise generator.
•	•	Five “wide-band noise” noise generators with seeds.
•	•	Five summation (DSF) oscillators, each with controls for phase, frequency, and spectral balance (waveform). The oscillators can also act as shape-variant wave shapers, creating rich harmonic variations to the oscillator input.  These can also be set to DSF or Integrated DSF oscillators, Jenny Oscillators, phase generators or noise from seed generators.
•	•	Five Multimode filters, with control of frequency and bandwidth/resonance. Possible filters are Low Pass, High Pass, Band Pass, Low Pass Shelf, High Pass Shelf, Notch, and All Pass. Filters are either 2-pole (12 dB/octave cutoff slope) or 1-pole (6 dB/octave cutoff slope). Each filter can be cascaded 1, 2, 3, or 4 times.
•	•	Five audio signal multipliers useful for creating Ring Modulation effects.
•	•	Two biquad (biquadratic) filter banks, which are banks of 48 related but independent biquad filters, with controls for frequency, frequency spread, bandwidth, bandwidth spread, spectral centre, and spectral weighting. This technology is used to create the physical models of winds, strings, and percussion. Four varieties of these filter banks are available: Scaled Resonances, Modal Amplitude Graphs, Vocal Formants, and Modal Manipulators.
•	•	Two sine oscillator banks, each producing 16 sine oscillators (partials) under matrix control.
•	•	Two Sine Sprays, which produce sine grains under matrix control.
•	•	Two Wave Banks, each producing five sawtooth, square, triangle or LeCaine (additive square) waves under matrix control.
•	•	Two Harmonic (Granular) Manipulators, which can manipulate the spectra in predefined Spectral Sets, or Live data from the Delay module. Harmonic Manipulators are in addition to Modal Manipulators (mentioned above), which also manipulate Spectral Sets and Live data.
•	•	Two Additive Synthesis banks. New to 9.0 – allows the user to use an additive synthesis model of 96 sine waves that can be manipulated in various ways similar to functions used in the biquad banks (frequency, frequency spread, bandwidth, center, etc.) See new Section 6.11.
•	•	Two Kinetic Physical Model banks. New to 9.0 - The Kinetic Model is a state-space model of a mass attached to a spring which is anchored within a 1-dimensional container of viscous fluid. The output of the model is the position of the mass. See section 6.12

Src	Dst	Description
•	•	Four delays, with control of delay times of the main delayed output and additional output taps. The VoiceDelay suitable for creating chorus and flanging effects, can be used for fast slap delays. The SummedDelay processes an aggregate of all input voices in one shared delay. The MicroDelay provides four short single-tap delay buffers for each voice. The FormulaDelay provides long delay times for control data used with EaganMatrix formulas.
	•	8 CVC (Continuum Voltage Convertor) outputs, allowing you to create up to 8 preprocessed control voltages for each voice for analog synthesizers. This requires that a CVC be connected.
•	•	Five independent sub-audio Shape Generators, each with controls for cycle mode, frequency, and trigger. Any formula may use any SG, and each formula independently selects a shape for its use of the SG. Shapes available are Ramp Up, Ramp Down, Pulse, Pulse at End, Triangle, Hann, 4 variations of S Curves, Square, Sine, Sample-and-Hold, and many other shapes attained by formula-specific SG phase modulation. Note: SGs are available as sources within each formula, and not in the matrix directly. They can be used in many ways from secondary envelope generators to iterative controls of all kinds.
	•	Soft saturation in the Master Section, for distortion and overloading effects.
	•	A Recirculator which can do digital reverb, modulated delay, or echo processing. The Recirculator gives the sound a sense of space and can be set manually or under dynamic program control.
	•	Two short Convolutions, one pre-Recirculator and one post-Recirculator. A variety of Convolution responses are selectable, both manually and under program control.
•		Stereo digital audio input (Continuum) or Analog Audio Input (EaganMatrix Module) for post-processing by the Matrix, from the Continuum Fingerboard's AES3/SPDIF In connections, or from other DSPs in a Continuum Fingerboard with EaganMatrix Expander (EaganMatrix Expanded no longer available). Note: This function does not apply to the ContinuuMini.
•		EaganMatrix Module Only: CV Input for Control of W, X, Y, Z offsets and Macro Controller i, ii, iii, iv, v and vi offsets
•		The submix from the Master Section, available to be reprocessed through the matrix structure.
•	•	Stereo output from other EaganMatrices, to be processed through this matrix (for Combination Presets). Note: This function does not apply to the ContinuuMini or Continuums with 2x or less processing. Best used with 6X Continuums.

### 1.3. Source and Destination Locations in the Editor

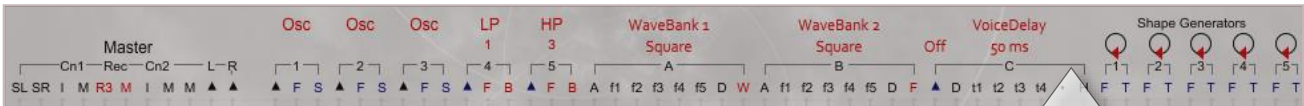

**Master Section**  
Soft Saturation, Pre-Convolution, Recirculator, Post-Convolution, Wet/dry Stereo

**Summation Oscillators and Filters +**  
Jenny Oscillators, Phase Generators, Noise from Seed and Signal Multipliers

**Three Multipurpose Banks**  
Biquad Filter Banks, Sine Oscillator Banks, Wave Banks Sine Sprays, Manipulators, Delays, CVC Control Voltages, Kinetic Banks, Additive Banks

**Shape Generators**

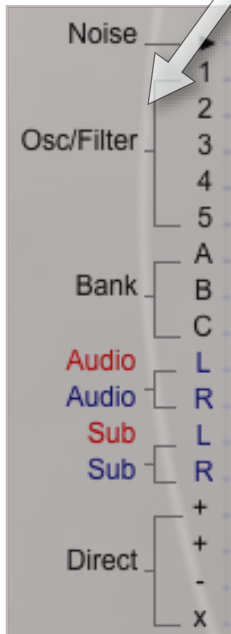
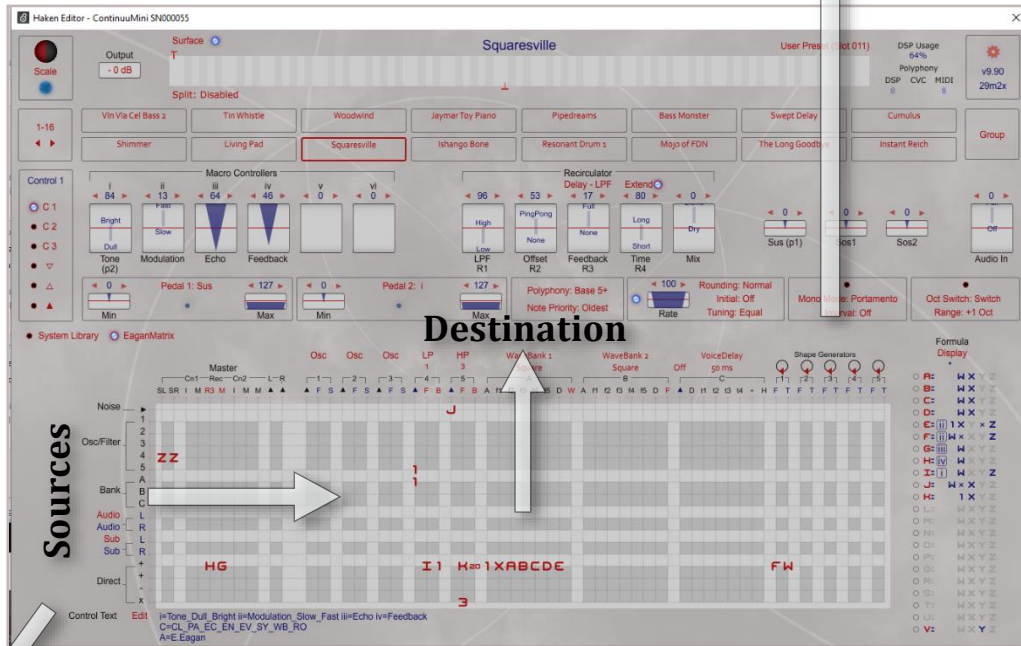

**Noise**

**Oscillator/Filter Banks:** Discrete Summation Formula (DSF) Oscillators, 9 different filters, Jenny Oscillators, Phase Generators, Seeded Noise, Filters and Multipliers

**Multipurpose Banks** Biquad Filter Banks (BiqBank, BiqGraph, BiqMouth), Sine Oscillator Banks, Sine Sprays, Harmonic and Modal Manipulators, Wave Banks (Saw, Square, Triangle, LeCaine), Kinetic Banks, Additive Banks, Delays, CVC Control

**Selectable Sources** Audio In - Continuum (AES, SPDIF), EaganMatrix Module (Analog) only, Delay Taps, Master Submix

**Direct** Positive, Negative, Multiply (Formula directly controls destination)



## 1.4. New Haken Editor / EaganMatrix User Experience (Post Version 9.55)

The Editor has been redesigned to incorporate a new user experience allowing for the expansion to 128 User Presets (in banks of 16), easier System Preset selection with filtering and Text Search (in System Preset mode) and a more well organized EaganMatrix programming environment (in EaganMatrix mode).

In EaganMatrix Programming mode (below), the EaganMatrix is displayed and can be edited as desired.

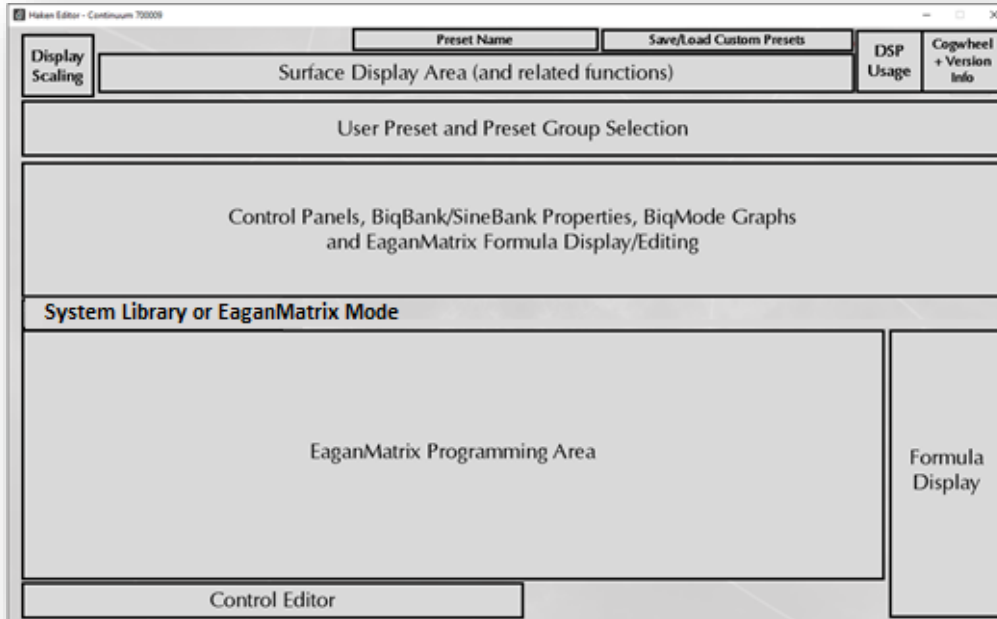

In System Library preset selection mode (below), EaganMatrix programming elements are replaced with System Preset selection options which are filterable by Category and sub-filtering..

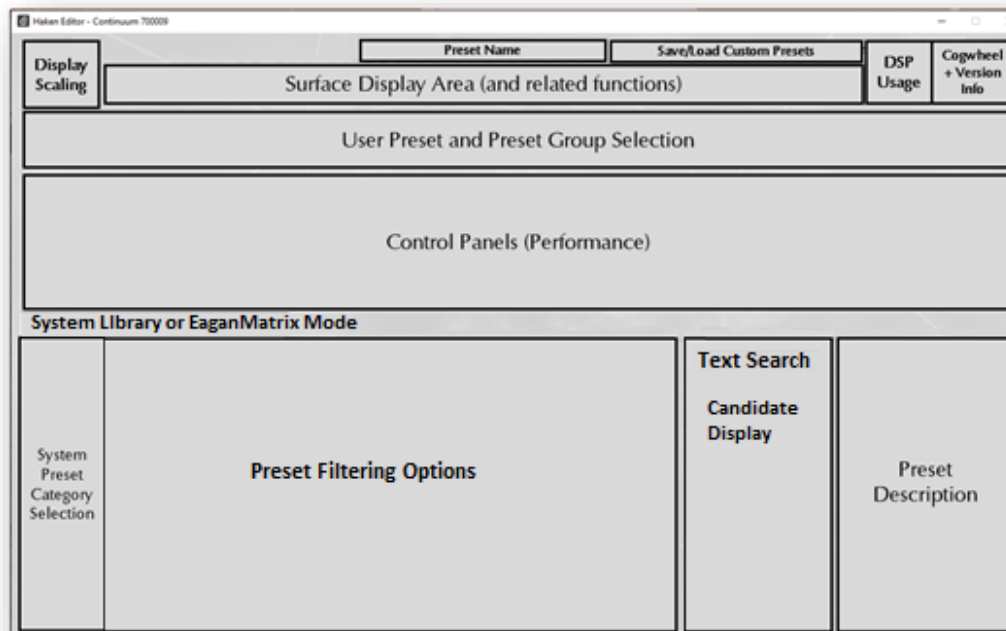

See the Continuum Manual for details on Preset selection Mode

Six selectable (through radio buttons on the left) Control Panels are incorporated to allow for a more organized and less dense user experience. The first three options present performance and general controls.

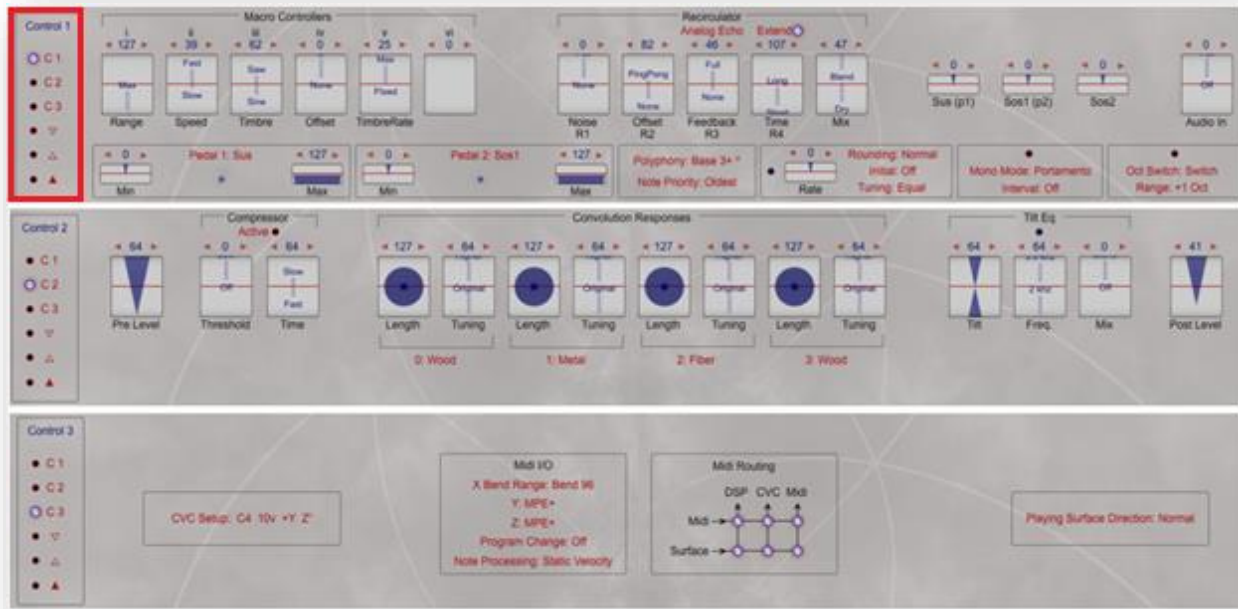

Three Parameter Displays Resulting in Control (1,2,3) Selections

The second three options allow for presentation and editing of the Graphs associated with BiqGraph control and also the new Graphing function that allows presets to incorporate an arbitrary pattern up to 48 notes long. Break points are also set in these graphing controls.

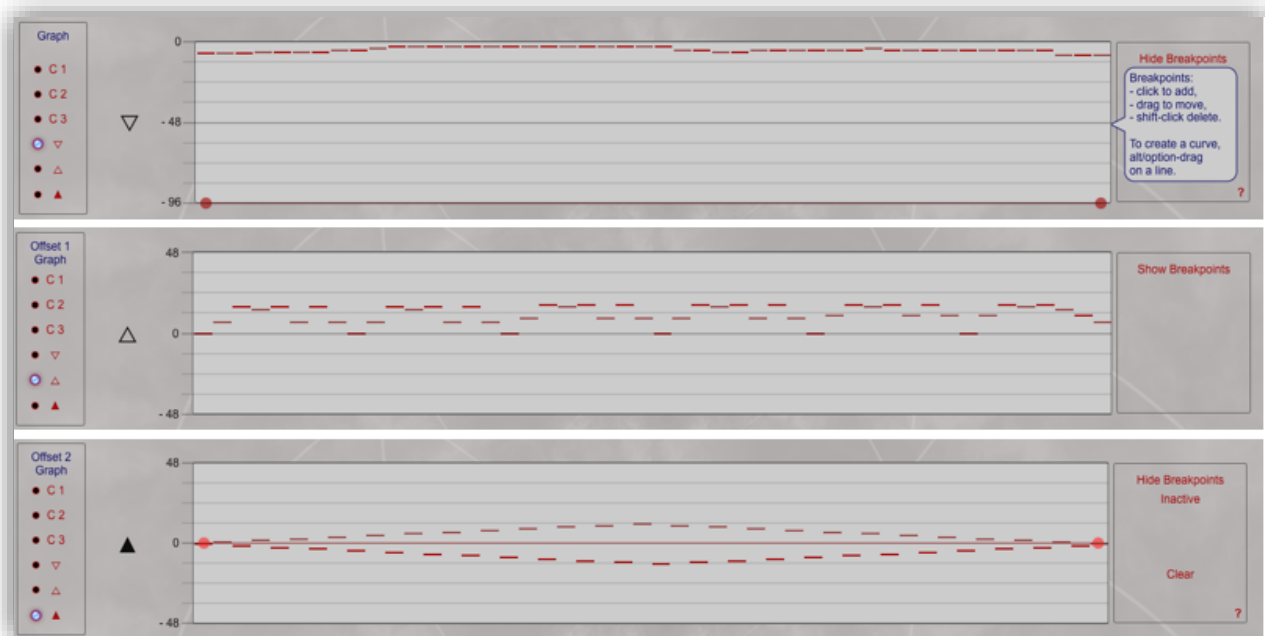

Three Graph Displays Resulting in Control (4, 5, 6) Selections

When a formula in the EaganMatrix is selected this Control Panel area is replaced with the formula editing panel.

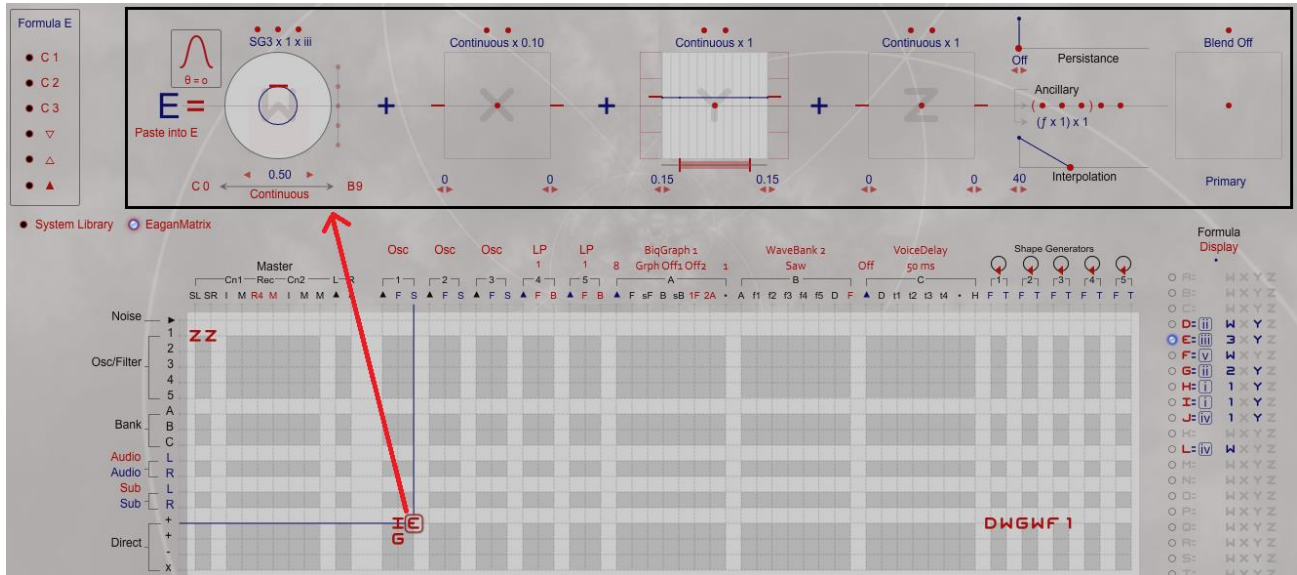

Selecting Formula (here "E") in the EaganMatrix displays the formula in the Panel area

Finally this panel area is also used to display BiqBank, SineBank and Kinetic Model Properties

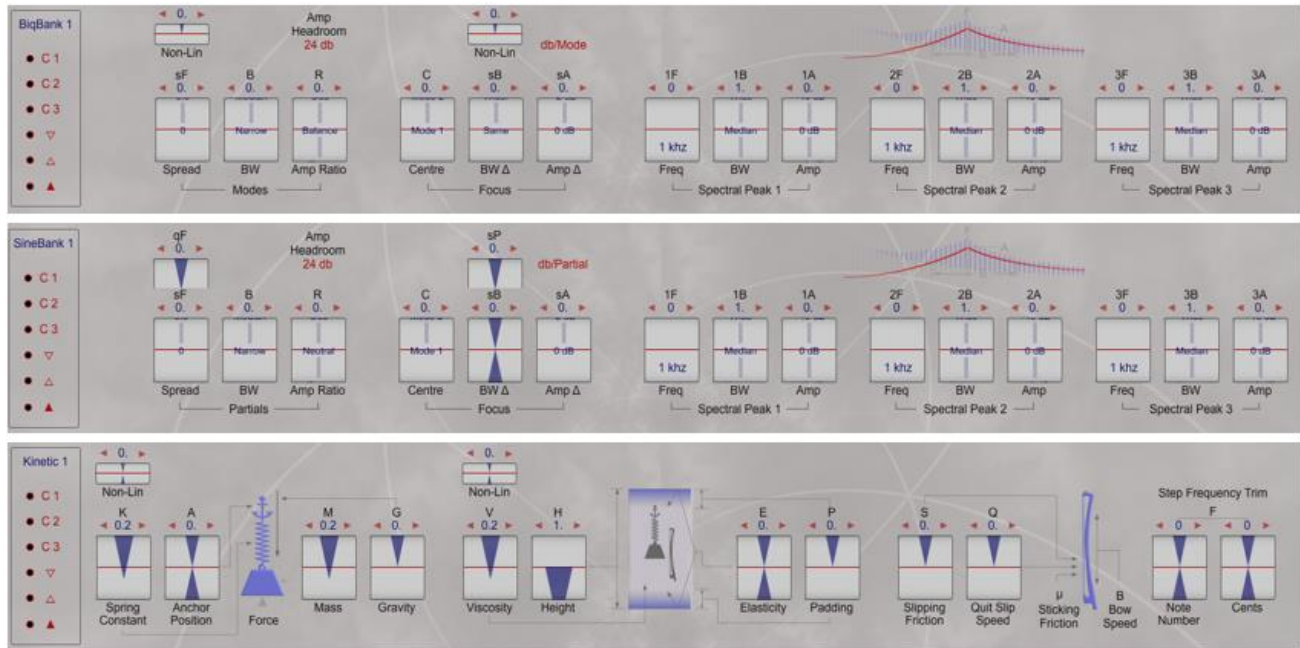

BiqBank, SineBank and Kinetic Model Properties Controls

## Haken Editor Control Panel Summary (Firmware 9.8 and later)

In the First Control Panel (C1) there is now:

- Macro Controllers (i, ii, iii, iv, v, vi – all now identical in function)
- Recirculator Control
- Sustain, Sos1, Sos2 Pedal display and control
- Audio Input Level
- Ped1 and Ped2 Range Settings (Pedals do not apply to EaganMatrix Module, or Ped2 to ContinuuMini)
- Polyphony and MPE Note Priority Control
- Rounding and Tuning / Pitch Map Control
- Mono Mode Control (Does not apply to ContinuuMini or EaganMatrix Module)
- Octave Switch Control

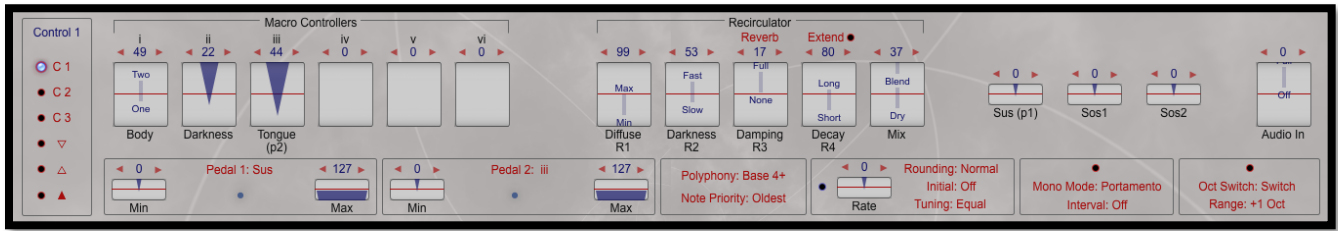

In the Second Control Panel (C2) there is now:

- Pre (Gain) Level
- Compressor (Provides slight compression)
- Convolution Settings
- Tilt EQ Settings
- Post (Gain) Level

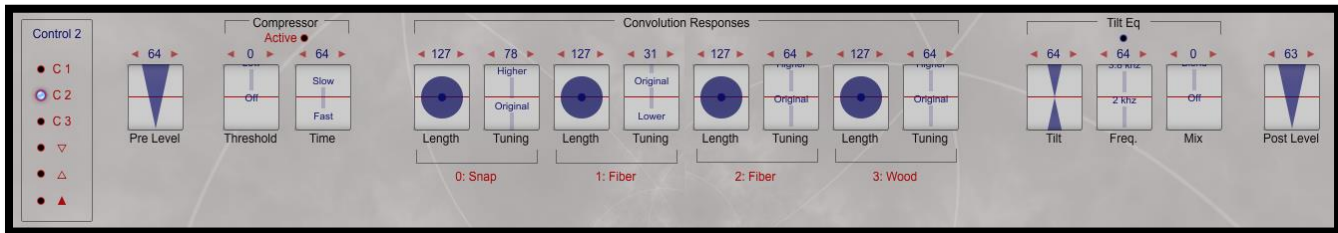

The Editor supports multiple themes/skins that are available in the Midi and Global Settings window – some suited for performance and others for programming. More may be added over time.

In the third Control Panel (C3) there is now:

- CVC Setup
- MPE Midi I/O Settings
- Midi Routing
- Playing Surface Direction control



Three screen Themes (skins) are available from the Midi and Global Setting window. Note that on loading new firmware the default dark theme will be applied and you will have to change it. Once changed it should come up that way until set to a different theme or until new firmware is loaded.



The Midi and Global Settings Window (accessible from the cogwheel) Includes important information on

- Connection state of the instrument
- External USB Interface Connections
- Preset loading Options
- Continuum Action (does not apply to EaganMatrix Module or ContinuuMini)
- AES State
- Editor Menu Size Control
- Theme control
- Fine Tune control
- Actuation Control (Slim Sensitivity Optimization)
- Quintizer Pedal Support (not yet supported).

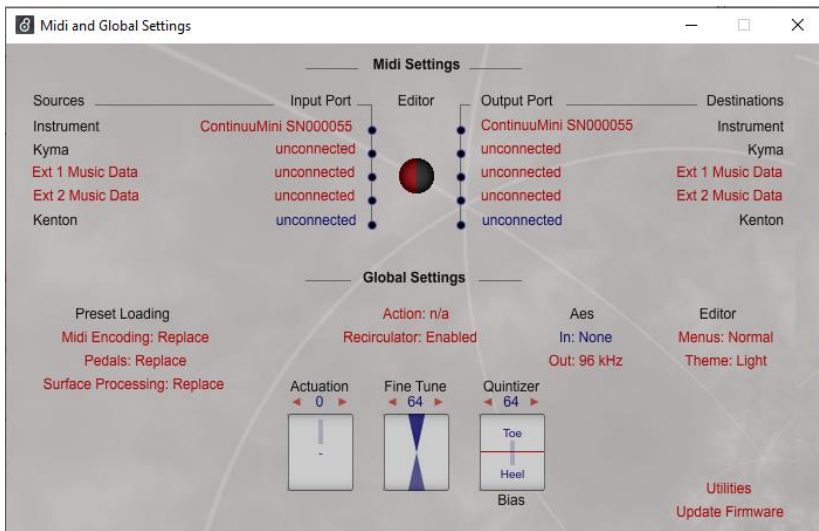

**Please Be Careful...**

Please be careful with your speakers (and ears) when programming the EaganMatrix! Due to its highly flexible nature, it is possible to create presets that spiral out of control, potentially causing very loud output. Get in the habit of lowering the Attenuation and Output Gain (especially Post output) before critical patching explorations. Never use headphones when programming the EaganMatrix in case you make a mistake and create a huge sonic outburst. Definitely do not get in the habit of "random" patching; successful sound design with the EaganMatrix requires understanding and planning, combined with careful experimentation. Be very careful when experimenting with noise and all the filter banks.

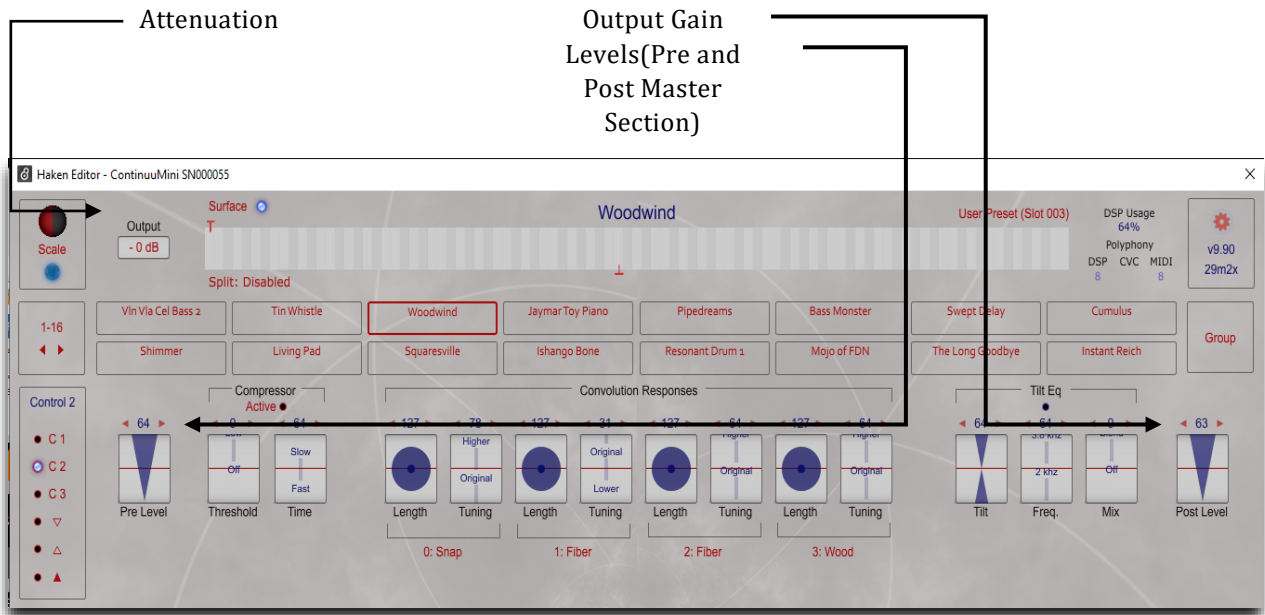

## 2. Basic Design Concepts

In analog synthesizers matrices are a compact way to maximize the number of input-to-output connection points in a small and concise area, rather than the more customary use of patch cables. The matrix idea has existed in analog modular synthesizers for some time, for instance in the 1970s EMS VCS3 analog synthesizer, its matrix pictured to the right.

For these traditional matrices, shorting pins are used to connect sources (labelled on the left) to the destinations (labelled on the top). A pin is inserted at the desired connection point in the matrix, creating a signal flow from source to destination.

In the VCS3 matrix to the right, a white shorting pin is connecting the output of Oscillator 1's sawtooth wave to the input of the Filter. A red shorting pin connects the Oscillator 3 triangle output to the frequency cutoff control of the Filter. Finally, two yellow shorting pins connect the Filter output to Output Channels 1 and 2.

These shorting pins pass the outputs unaltered to the connected input. Finer signal control is achieved by supplying various control knobs on the synthesizer (i.e. a knob to control the shape of the oscillator waveform or another to control the oscillator's fundamental frequency).

Like the VCS3, the heart of the EaganMatrix is its matrix, but unlike the VCS3, the execution of its matrix has been greatly expanded by adding the ability to place a powerful mathematical formula directly inside a connection point.

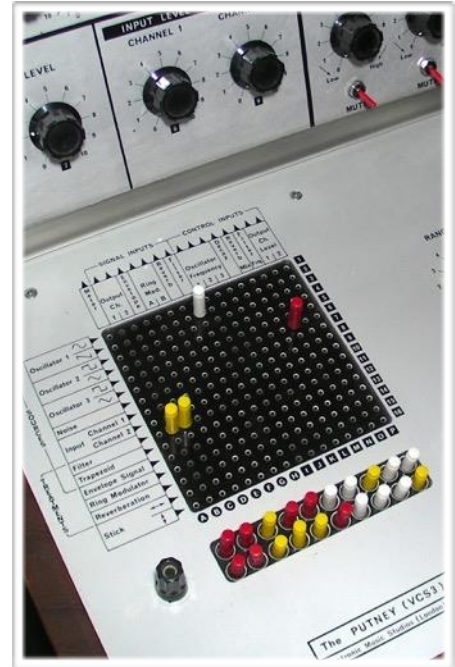

### 2.1. The Matrix in the EaganMatrix

Pictured here is a similar patch to the previous one shown in the EMS VCS3, except this time executed in the EaganMatrix:

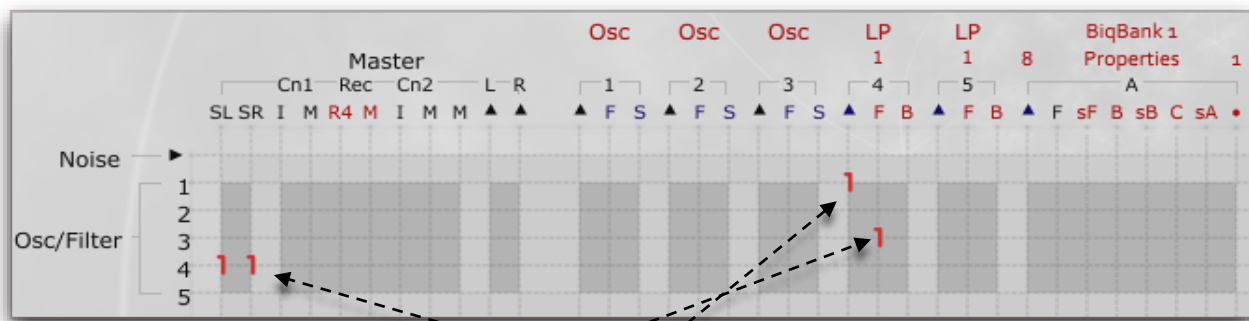

Again, sources are labelled on the left and destinations are labelled on the top. Instead of pins as used in the VCS3, red numbers are at the location where a VCS3 shorting pin would be, this red number representing the connection from source to destination. Notice that a **number 1** (unity value) is connecting the output of Oscillator 1 to the input of one of the filters in the EaganMatrix. This number 1 represents a unity gain from source to destination. Another **number 1** is connecting the Oscillator 3 output to the frequency cutoff control of the Filter. Finally, **two number 1s** are connecting the Filter output to Output Channels Left and Right.

In the EaganMatrix, the simplest virtual pin connection is represented by a numerical constant, like these number 1s above. However, patch points can be modified in more subtle and complex ways. For instance, to have half the amplitude (volume) of Oscillator 1 go into the input of the Filter, the number 1 at that connection point can be changed to the constant .50 (half of 1), as pictured below:

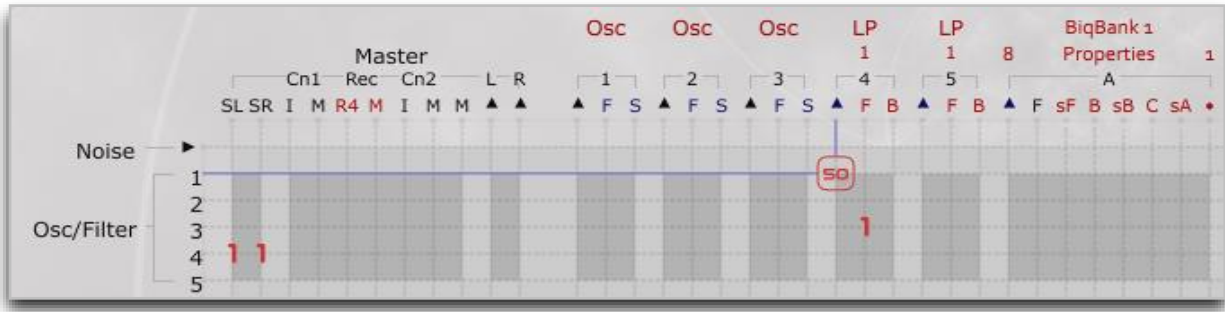

Of course, other numbers can be added. For instance, to have 1/4 of the amplitude of Oscillator 1 go into the Filter, and to triple the influence of Oscillator 3 on the cutoff of the Filter, use numbers .25 and 3, respectively:

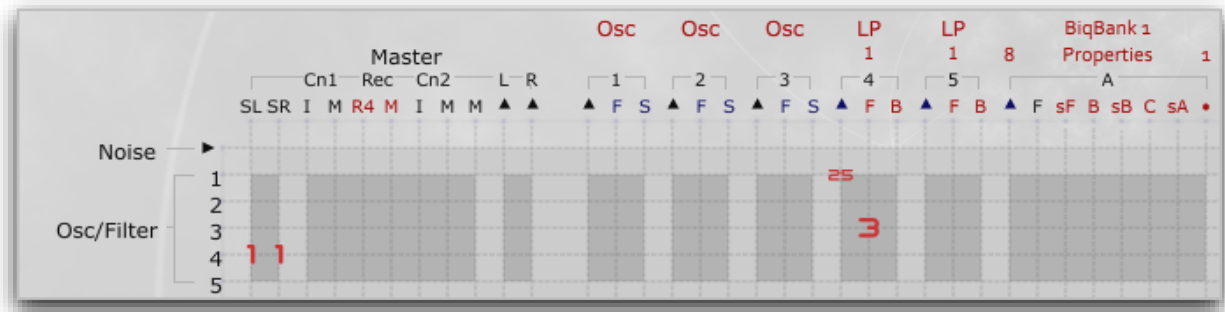

## 2.2. Playing Surface to Formula Connection

This is just the beginning of the patching possibilities in the EaganMatrix. Connection points can be dynamic rather than static, in the sense that they can change over time and through external influence. For the EaganMatrix, this external influence is primarily the Continuum playing surface. These dynamic matrix patching pins are formulas, graphically represented by the letters A through V (variable formulas) and the letters W, X, Y, and Z (fixed formulas). The user-programmable structure of the formulas A through V automatically becomes visible when that formula is placed or selected inside the matrix. Pictured below is one such formula, Formula A:

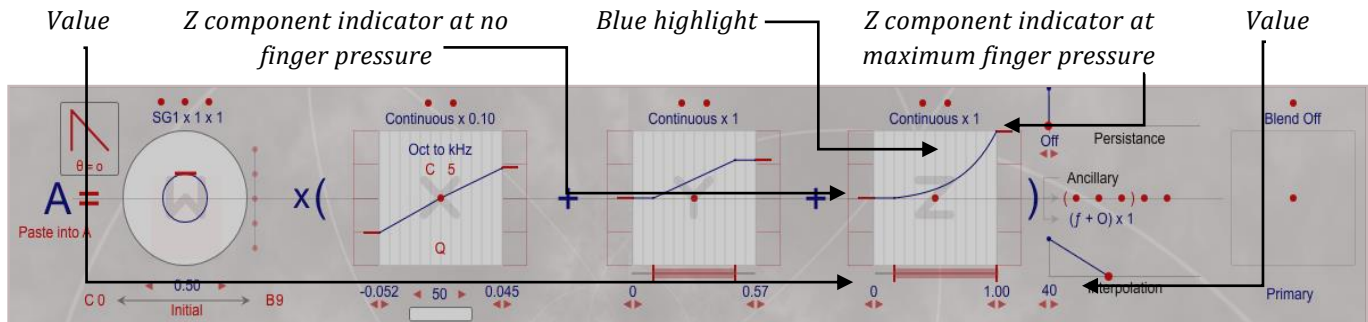

Formulas can mathematically represent input in three dimensions from the playing surface, as well as interactions with Shape Generators, pedals, Macro Controllers (old “Barrels”), and other formulas within an EaganMatrix preset. This formula structure is truly what makes the EaganMatrix powerful. In the formula pictured above, only the Z component (pressure input from the Continuum surface) is active.



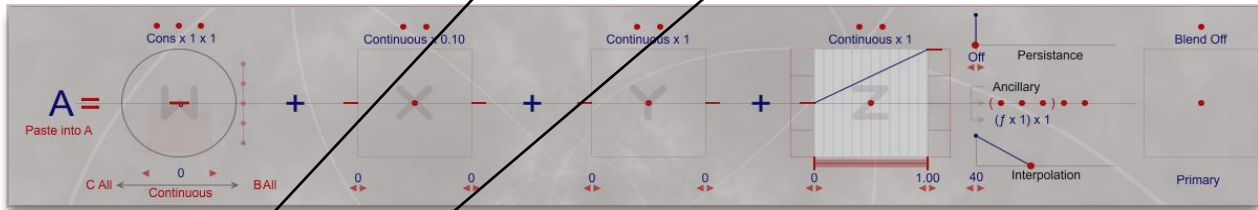
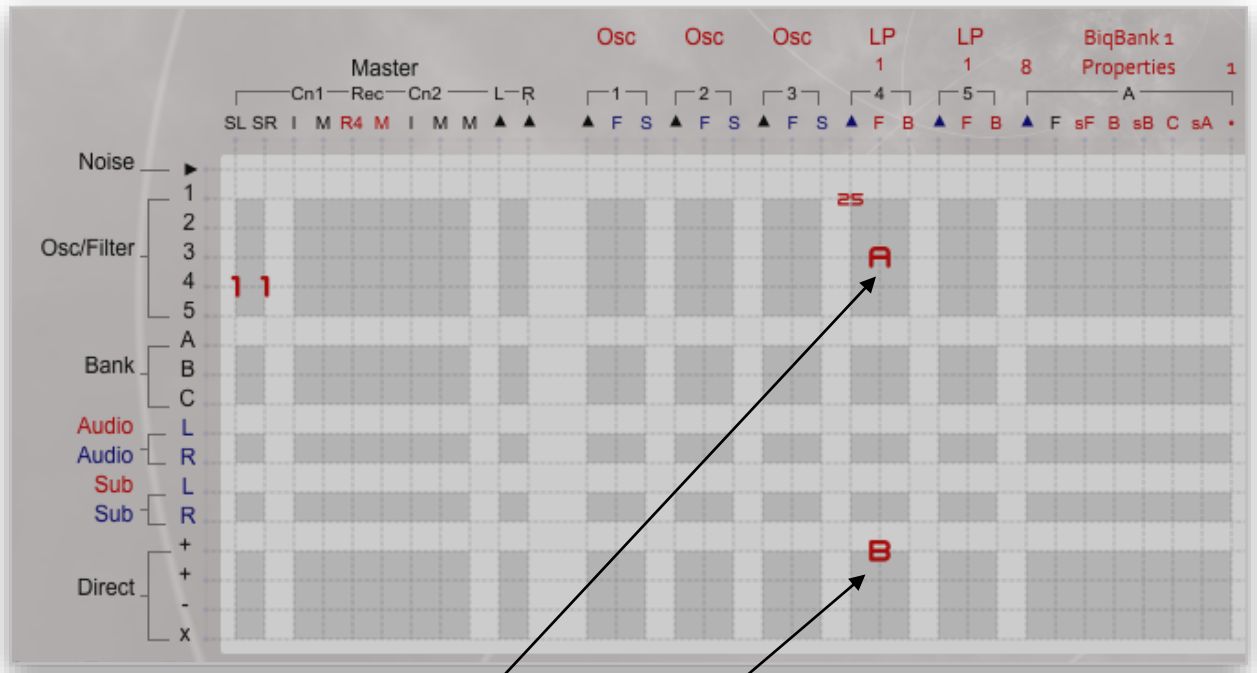

With this **Formula A** placed into the Matrix, the frequency of a filter (osc/filter 4) is now controlled by an oscillator (osc/filter 3) via finger pressure, and only finger pressure, as the Z component of Formula A is the only part of the formula that is active. This finger pressure controls the amount that osc/filter 3's output is influencing the frequency of osc/filter 4. Formula A's Z component is at 0 with no finger pressure, and at 1 when there is maximum finger pressure (in this case using linear scaling).

**Formula B** has also been placed at the intersection of filter 1 frequency column and a Direct+ row.

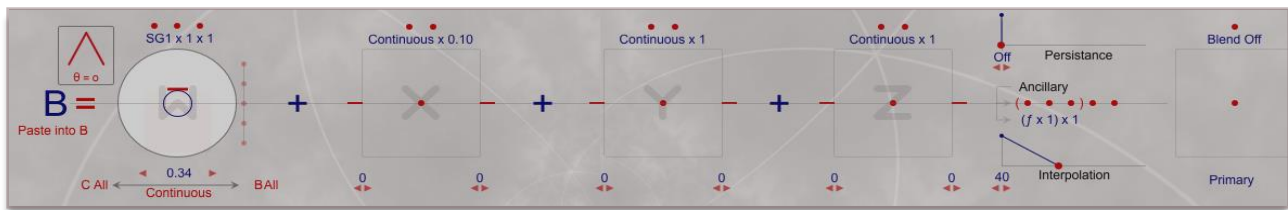

A Direct+ row has a constant value of 1, instead of a variable value like Osc3's output. Formula B has only the W component active, set to a value of 0 to 1 based on the current value of Shaper Generator 1. In a filter frequency column, this means it has a varying value from 0 to 1 kHz (with triangle shape). This is added to the value of Formula A to determine the actual setting for the frequency of filter 1.  $(\text{Osc } 3 * \text{Formula A}) + (1 * \text{Formula B}) = \text{Filter 1 Frequency}$ .

### 2.3. Formula Creation Basics

Formulas are created by selecting one of the "A" through "V" formula radio buttons on the right-hand side of the screen or typing a formula letter into the matrix at the desired source/destination intersection. In both cases the formula panel will be displayed allowing the user to create the formula or showing the current formula components if it already been created.

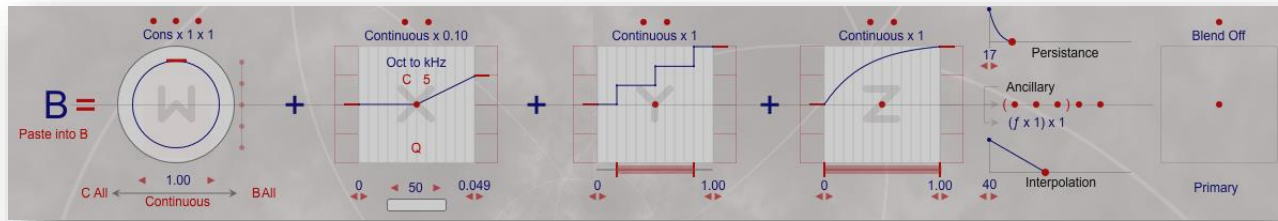

Here Formula A has been created and placed into the Matrix. It is colored red in the matrix and also turned from black or light gray (depending on the window theme/skin) to red in the right-hand side formula selection list. Formulas letters in the list that are selected for creation but not entered into the matrix are colored black or light gray (again depending on the window theme). Formulas that may be defined but not entered into the matrix or formulas that have been deleted from the matrix will disappear on saving and reloading the preset. If you want to save a formula that is not currently used into the matrix, enter it on an unused component that will make no sound for that formula in that position.

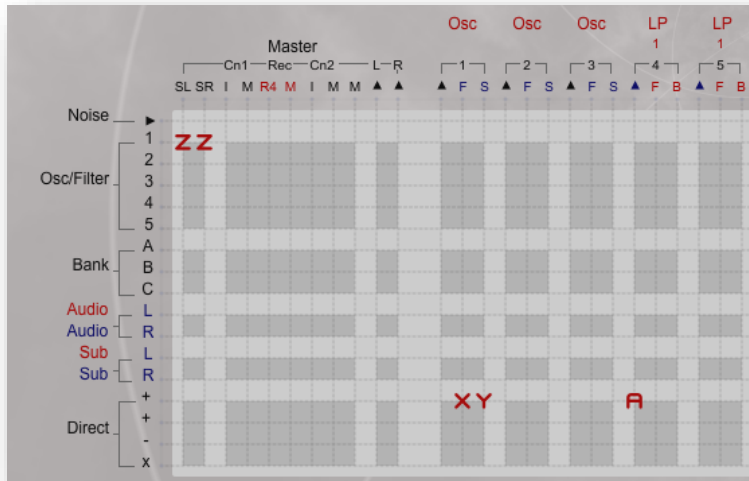

*Formula A is non-functional in this example and will be stored on save and load of the preset*

Once formula components are set, the active components of a formula are indicated by a **blue highlight**. These indications include W, X, Y and Z components, Controls and Shape Generators. The formula precedence selected is also indicated with the associated math operator "+" or "-" in red (See section 7).

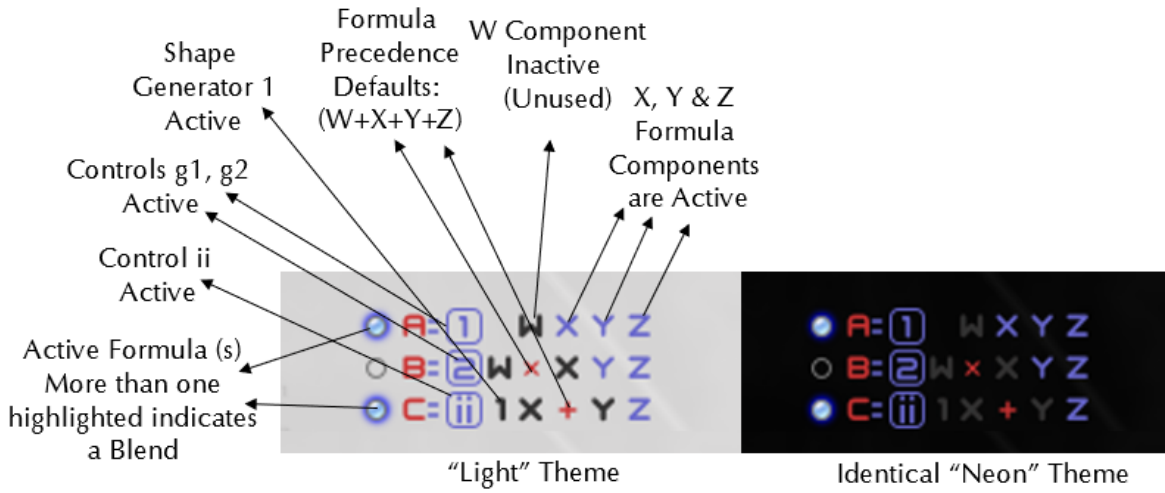

Numeric Constants (whole and fractional) and predefined W,X,Y,Z components can also be entered into the matrix along with user defined formulae "A" through "V".

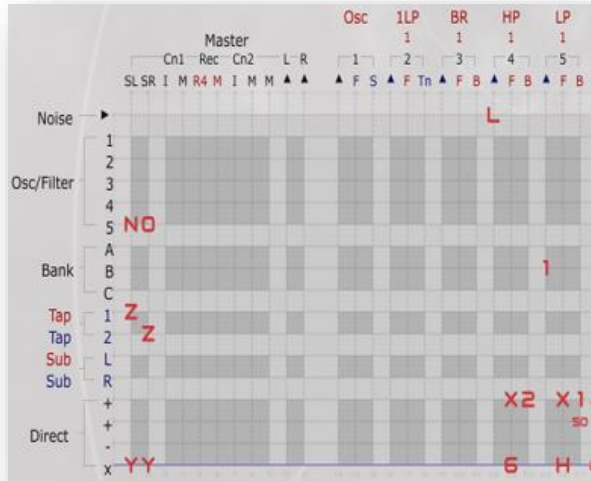

## 2.4. WXYZ - The Four Components of an EaganMatrix Formula

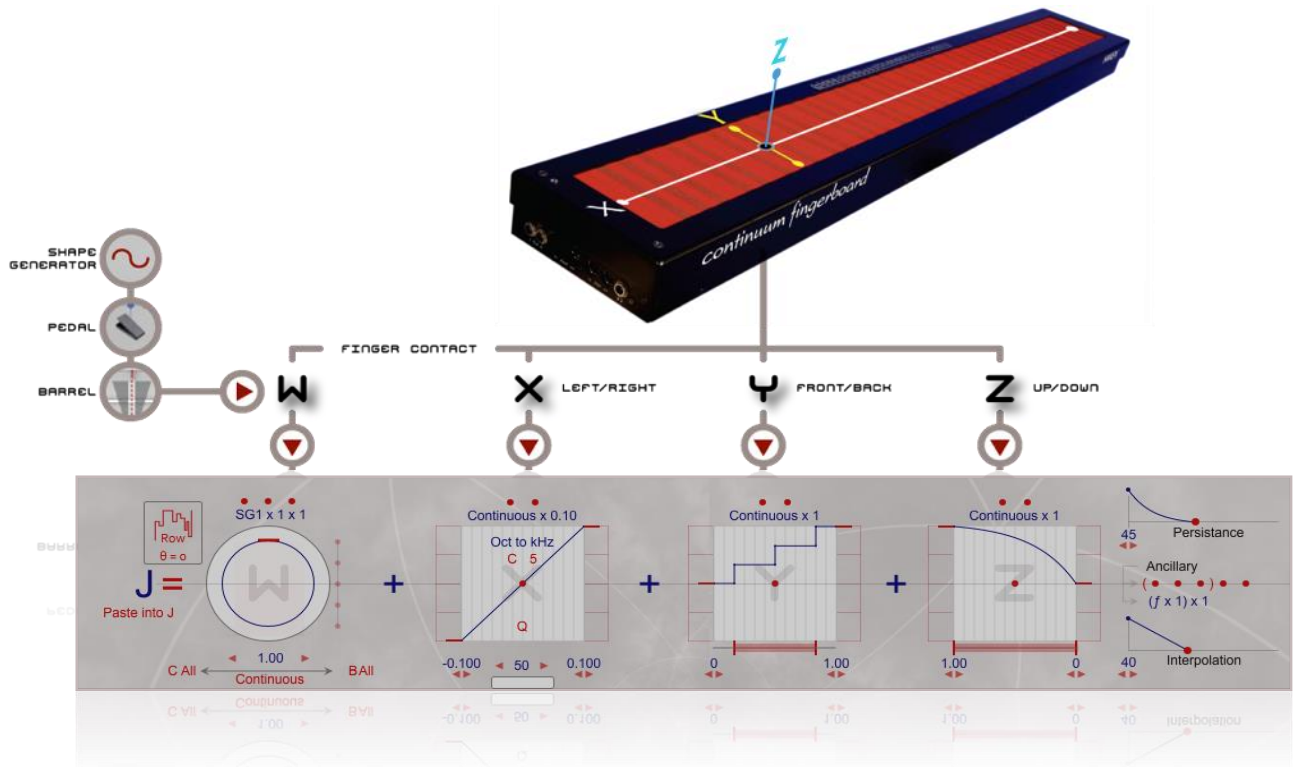

A

The basic EaganMatrix formula is divided into four components, labelled in the formula graphic as W, X, Y, and Z.

The W component is active when a finger is in contact with the playing surface, or optionally active all the time. The W component can include influence from Shape Generators, sample-and-holds, controls, foot pedals, and other formulas.

The X, Y, and Z components of the formula correspond to a particular playing direction in the three dimensional space on the Continuum surface. The X, Y, and Z components each have a programmable transfer function (a.k.a. “input-output mapping”). In formula J above, the Y component has a three-step transfer function, and the Z component has a squared transfer function. The full set of transfer function options for X < Y and Z are:

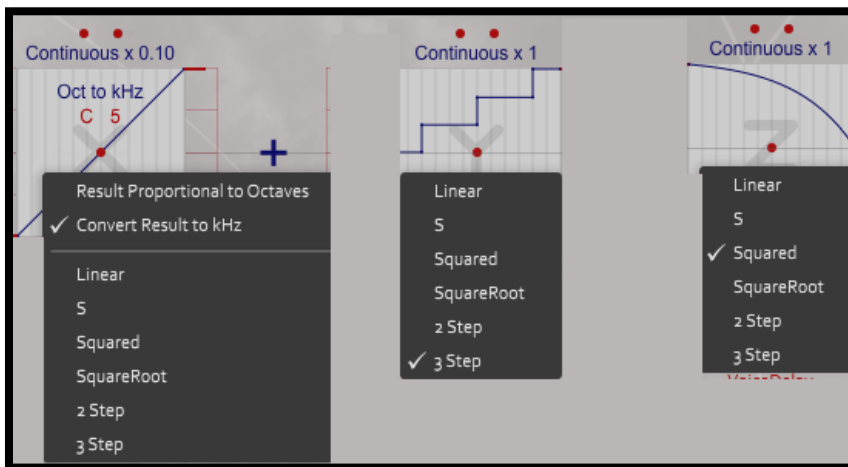

The four components, W, X, Y, and Z, can be combined by various methods involving a selection of addition and multiplication operator precedence. Click on the Formula letter to change the W,X,Y,Z precedence to one of five options (default is to add all together):

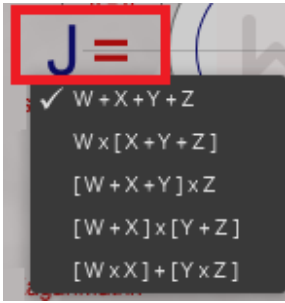

This streamlined yet flexible design architecture means that formulas can be tailored to respond to countless blended combinations of performance data from the Continuum playing surface. Note that in addition to using them as formula components, W, X, Y and Z can be used as fixed formulas applied directly to EaganMatrix patch points.

These formulas can also be expanded with Primary and Secondary Ancillary operations available on the right hand side of the formula display (see more details below):

The screenshot displays the EaganMatrix interface with a formula editor at the top. The formula is  $J =$  followed by several graphical components: a circular component labeled 'SG1 x 1 x 1', a linear component labeled 'Continuous x 0.10', and two step-like components labeled 'Continuous x 1'. Below the formula, five panels are shown, each with an 'Ancillary' header and a list of options:

- ANCILLARY OPTIONS:** Includes checkboxes for 'Evaluate using Voice's Finger', 'Use Touch Area (or All Fingers Averaged)', 'Ancillary Domain is Whole Formula', 'Disregard Graphs', 'Bypass Output Conversion', and 'Do Not Modify Matrix Column's Limiter'. It also has sliders for 'Graph Lookup', 'Offsets 1 Lookup', 'Offsets 2 Lookup', 'Integer Graph', 'Integer Offsets 1', and 'Integer Offsets 2'. A 'Midi Clock' option is at the bottom.
- PRIMARY ANCILLARY OPERATORS:** Includes 'Multiply', 'Absolute then Multiply', 'Invert then Multiply', 'Divide', 'Add', 'Subtract', 'Power (a^b)', 'Log', 'Modulo', 'Quantize', 'Minimum', 'Maximum', and 'Crossing Detect'.
- PRIMARY OPERANDS:** A list of letters G through V, with 'C' selected.
- SECONDARY ANCILLARY OPERATORS:** Includes 'Multiply', 'Absolute then Multiply', 'Invert then Multiply', 'Divide', 'Add', 'Subtract', 'Power (a^b)', 'Log', 'Modulo', 'Quantize', 'Minimum', 'Maximum', and 'Crossing Detect'.
- SECONDARY OPERANDS:** A list of letters G through V, with 'J' selected.

### 3. Exploring the EaganMatrix

Due to the radically new design of the EaganMatrix, we highly recommend you go through the tutorials in this User Guide. The tutorials will familiarize you with the fundamental programming aspects of the EaganMatrix. If you have not done so already, please read the Continuum User Guide prior to starting the tutorials.

After finishing the tutorials, you may learn advanced techniques by studying the designs of the EaganMatrix system presets. You can create user-defined presets using system presets as starting points for further sonic explorations.

The picture below shows the location for accessing System Presets and where to work with custom Presets. The EaganMatrix System Presets are listed via categories on the left, and then can be further filtered based on Type, Character, EaganMatrix functions used and setting (see Continuum Manual). In addition a search by Text function is included that will allow you to type in a string and presets with that string in the name will be displayed for selection. Selecting a system preset will load it into the Continuum as well as the Editor, where it can be modified in the EaganMatrix if desired. Black triangles will indicate what filtering options apply to the selected preset.

When you work on a User Preset of your own, you should not only store it as a User Preset inside the Continuum, but also use "Save" to store it to your computer's file system. When you use "Save", you will have the opportunity to choose a name for your preset. You can also store the current preset to a User Preset position.

The screenshot shows the Haken Editor - EaganMatrix Module interface. Annotations with arrows point to various parts of the interface:

- Current User Preset Bank Selected (8 banks of 16 available = 128):** Points to the top-left area showing the current bank and available banks.
- Current EaganMatrix Preset Category:** Points to the 'Category' filter in the bottom-left list.
- EaganMatrix Preset Filtering Options and search by Text:** Points to the 'Type', 'Character', and 'EaganMatrix' filters, and the search bar.
- Current EaganMatrix Preset Loaded (system, user, or custom):** Points to the 'System Preset (Slot 0422)' label at the top right.
- Preset Open/Save:** Points to the gear icon in the top right corner.

The interface includes a grid of preset buttons (e.g., Sawblades, FM DreamPiano, Shimmer, Dropaphone, CZ Dirt Bass, Soundboard, Bajaron Light Ship, Magic Carillon), a control panel with various knobs and sliders (e.g., Detune, DelLvl, DelTime, Reverb, ModDepth, ModRate, Feedback, Time, Mix), and a bottom-left list of categories and characters.

**Legend:**  
 X: Pitch  
 Y: Not Used  
 Z: Volume, brightness, and pitch detune  
 Ped1: Sustain  
 Ped2: Sostenuto

In addition to the System Presets, 128 User Presets are stored inside the Continuum Fingerboard, viewable in the editor in banks of 16 presets. These User Presets can simply be copies of System Presets, or customized versions of System Presets, or Presets created from scratch. Simply click one of the User preset positions to load it as the current preset.

Additional Presets can be opened from your computer's file system by clicking on the "Current Preset" button and choosing Open. A standard dialog box will appear prompting for a file location.

## 4. Tutorials

The tutorials require presets that are not stored inside the Continuum. In order to perform the tutorials, locate and open the Preset files "Simple FM Tutorial.mid" (Tutorial 1) or "Resonant Drum Tutorial.mid" (Tutorial 2) which reside in the Tutorial folder within the User Guide folder.

### 4.1. Tutorial 1: Simple FM

Run the Continuum Editor and open the Preset file "Simple FM Tutorial.mid" located in the in /User Guides/Tutorial sub-folder. We'll use this preset to look at the data flow and formulas used inside the EaganMatrix. When the preset is selected the Continuum page of the Editor should look like this:

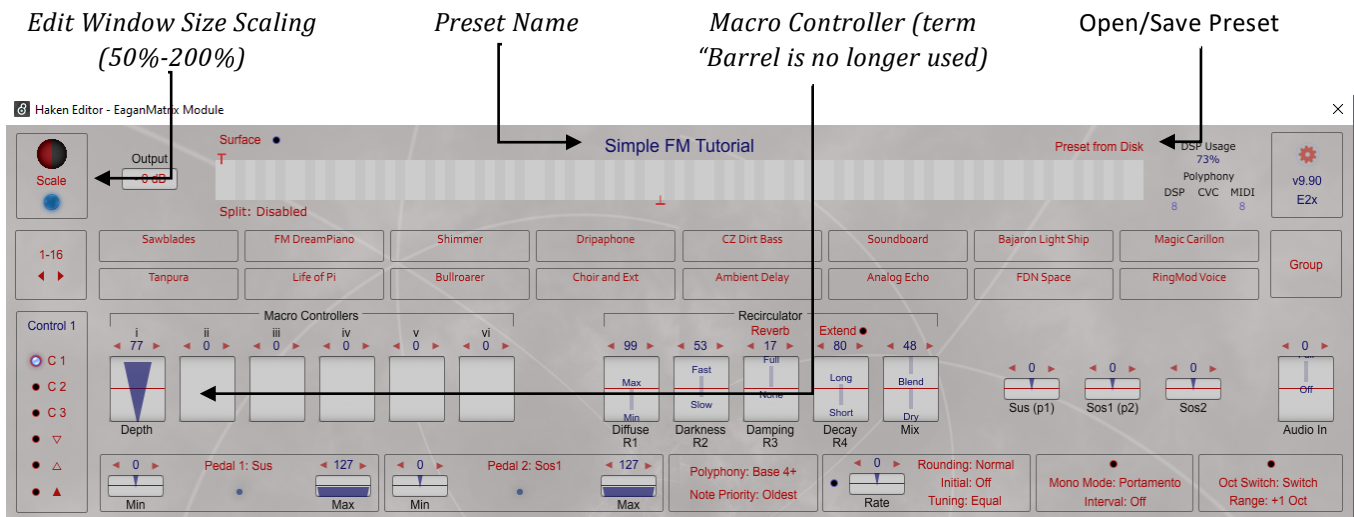

This preset uses only one of the six possible Macro Controllers (note that the previous term "barrel" is no longer used or "Gen1"/"Gen2" or "g1"/"g2" (they are now all labelled and referred to as Macro Controllers). Macro Controllers "i", "ii", "iii", "iv", "v" and "vi" are all now identical in terms of configuration and operation. A more flexible naming configuration is also supported in the Control Editor. Please see the Continuum manual for information on adding and using them in the Haken Continuum Manual.

The designer of this preset has used Macro Controller "i" to allow the performer to make sonic variations of the sound. Play this preset and listen carefully as you try it out. This preset is a basic two operator FM sound, using oscillator sine waves. When a finger presses on the Continuum's playing surface while this preset is loaded, the finger's X (left to right) position controls pitch, the finger's Z (pressure) controls amplitude, and the finger's Y (front to back) position does nothing. Play a note and move the control "i", also labelled "Depth", and notice how the timbre changes. This control has an effect on the depth of the FM modulation, in this case Oscillator 2's modulation depth of Oscillator 1.

Click on the "EaganMatrix/System Preset" toggle text at the middle left-hand side of the window to select the Matrix View to see the EaganMatrix. Or use the keyboard shortcut, Command+L (Mac) or Control+L (Windows). If desired, after

the EganMatrix is displayed, select the Scale option at the upper left-hand corner of the screen to change the size of the window from 50% to 200% of the default size.

The large edit window shows the Matrix Area of the Editor. Sources are labeled on the left, and destinations are labeled on the top. Signals flow from the sources on the left through an active matrix point, then to the destinations on the top. These destinations will in turn compute new source values for the next sample interval. The red alphanumeric in the matrix are active matrix patch points.

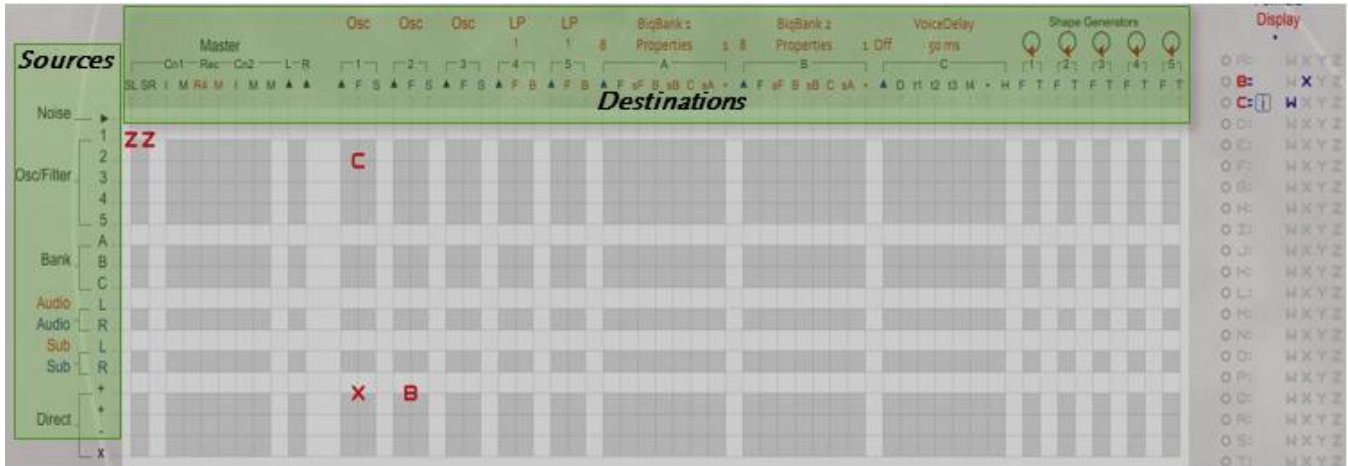

In this particular preset, two oscillators are used, Oscillator 1 and Oscillator 2.

The EganMatrix has four pre-defined Formulas, W, X, Y, and Z; and twenty-two user-defined formulas, A through V. This preset uses pre-defined Formulas X and Z, and user-defined Formulas B and C.

Oscillator 1 (the FM carrier) is routed to the Master Section (the EganMatrix output section) using the pre-defined Formula Z. Formula Z implements a squared function of finger pressure. Typically a squared-pressure function like this is ideal for finger control of amplitude. This is why it is being used here.

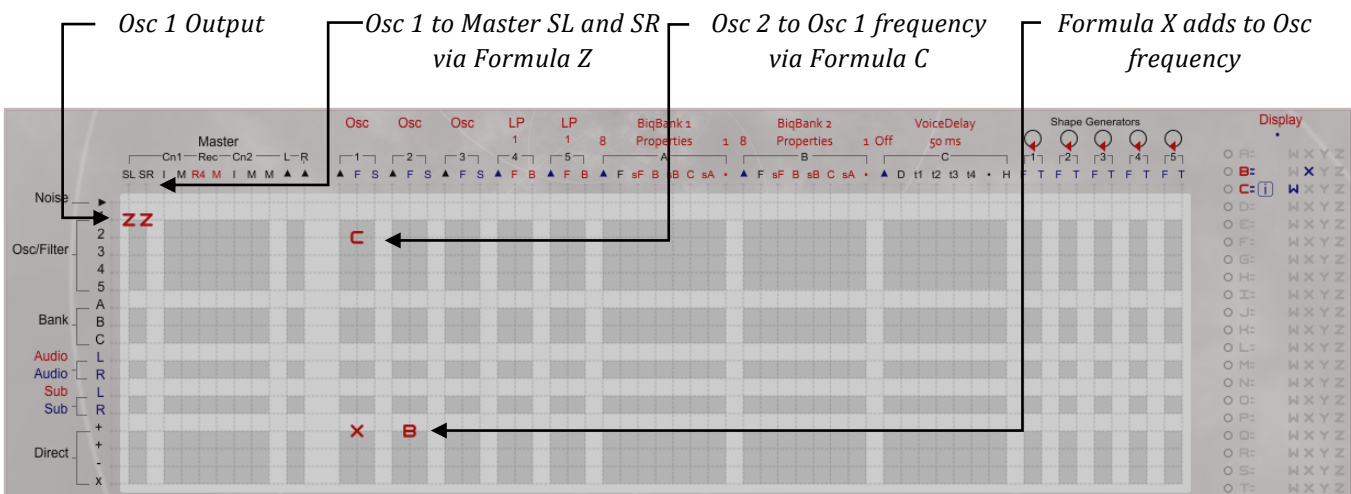

Oscillator 1's frequency is being controlled by the influence of two formulas, X and C. Pre-defined Formula X is in a Direct+ row, so it will directly affect the frequency of Oscillator 1; the Direct+ rows do not route audio signals, instead formulas in the Direct+ rows directly add into the matrix column. Formula X will cause the frequency of Oscillator 1 to track the X direction (left to right finger position) of the Continuum surface, so that the pitch goes higher to the right and lower to the left. Formula C controls the amount of modulation added to this frequency by Oscillator 2.



Formula B controls the frequency of Oscillator 2 (the FM modulator).

This creates a classic FM style of synthesis. Click on the C formula in the matrix. The screen will update, highlighting the selected matrix point with including crosshairs to easily locate source/destination and showing the selected formula above the Matrix in the Control area.

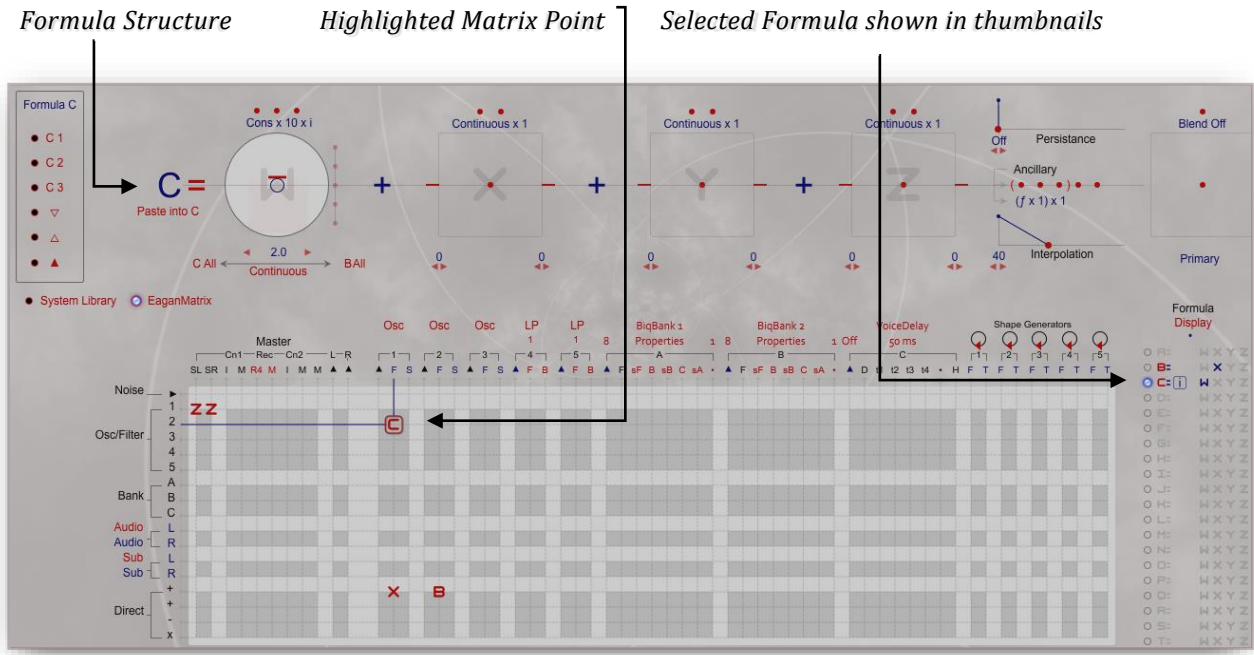

Look at the formula structure. This formula is being used to control the output of Oscillator 2 into the frequency of Oscillator 1. The W circle is highlighted, meaning that the W component contributes to the formula. The X, Y, and Z components are not highlighted, indicating they do not contribute to the formula. The Continuum surface X (left to right), Y (front to back), and Z (pressure) will have no effect on changing this formula's output, since those components each have value zero in this formula.

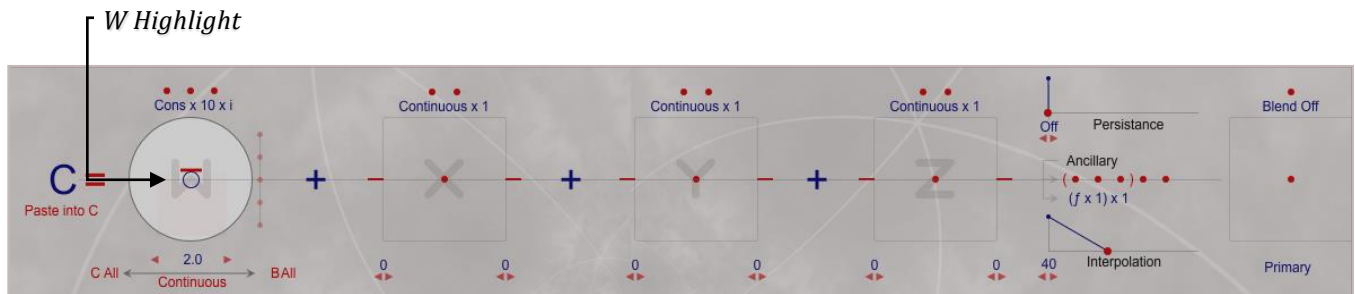

The W stands for Window. This W component of the formula can be used to generate a non-zero value while the finger is in contact with the surface, or optionally it can generate a value independent of finger contact. The math for the W component of this formula is above the round W icon. Red Dots above it are used to define the math for the component in terms of a Mode, Multiplier and Modifier described below.

The math for the W component of EaganMatrix formulas is: **W Mode** x **W Slider** x **W Multiplier** x **W Modifier**.

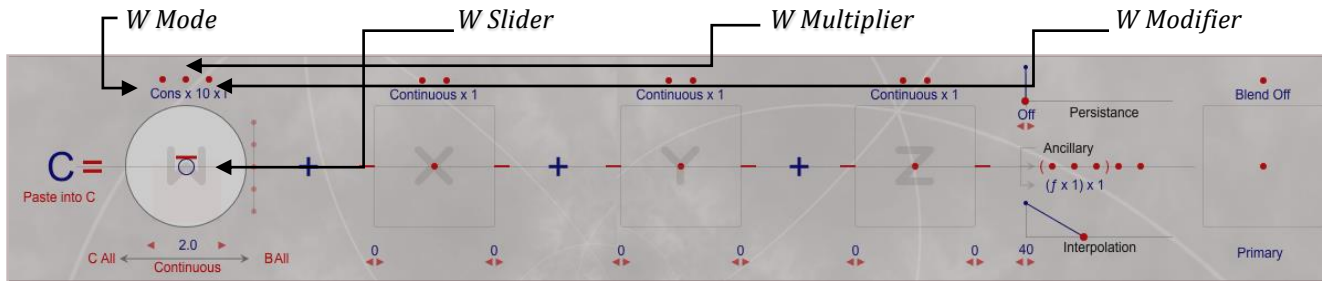

The **W Mode** in the example above is “Constant” (abbreviated Cons), always having a value set with the W Slider (2.0 in this case). This means that the W component’s value will be persistent, keeping its value even after the finger is lifted from the playing surface. Other choices are:

- “Gated” with a finger in contact, W Mode has value 1; when the finger is lifted, W Mode has value 0,
- “SG1” W Mode value depends on the state of Shape Generator 1,
- “SG2” W Mode value depends on the state of SG 2,
- “SG3” W Mode value depends on the state of SG 3,
- “SG4” W Mode value depends on the state of SG 4,
- “SG5” W Mode value depends on the state of SG 5,
- “SG1B” W Mode value depends on the state of SG 1B (if SG1 has “Dual” selected),
- “SG2B” W Mode value depends on the state of SG 2B (if SG2 has “Dual” selected),
- “SG3B” W Mode value depends on the state of SG 3B (if SG3 has “Dual” selected),
- “SG4B” W Mode value depends on the state of SG 4B (if SG4 has “Dual” selected),
- “SG5B” W Mode value depends on the state of SG 5B (if SG5 has “Dual” selected),
- “FormulaDelay” W Mode value depends on an output of the FormulaDelay.

The **W Slider** has a normal range from -1.0 to 1.0 easily selected in .25 increments using the black selection dots to the right (though you can increment with the slider or up/down arrow keys to 0.01 increment in the default setting); in the example above it is 0.2. The **W Multiplier** has a range from 0.001 to 1000; in the example above, it is 10 (why the W value displayed is 2.0 and not 0.2). Finally the **W Modifier** allows the W component to be modified from an external controller, such as the i, ii, iii, iv, v or vi controls. (Note: The W Slider can be extended past the normal range of +/-1.0 to +/- 1.27 which is useful at times when a value a bit above or beneath the normal range is desired without having to rescale).

In general, control values are scaled 0 to 1 when used in EaganMatrix formulas. In this W component, control “i” is multiplied by 0.2 (W Slider) and by 10 (W Multiplier). So the modulation of Oscillator 2 into Oscillator 1’s frequency will be scaled by a value from 0 to 2, depending on control “i”. Incidentally, if a foot pedal connected to the Continuum’s pedal jack controls control “i”, it will be at much higher resolution than the normal 7-bit Midi resolution.

Now click on the B in the matrix to have a look at that formula.

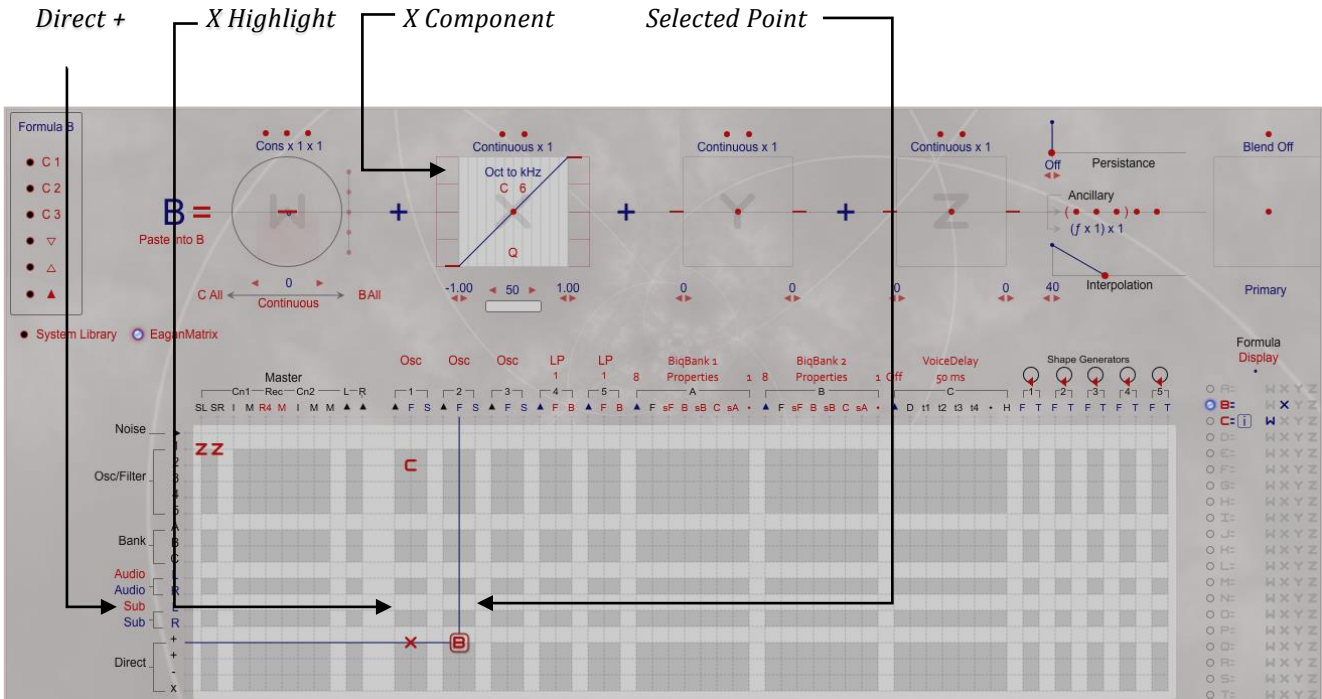

Formula B is being used to control the frequency of Oscillator 2. B is in a Direct+ row, which means it's not passing information from Source to Destination, but instead is directly controlling the Destination (mathematically it's as if the source input was a constant of 1 and is multiplied by the formula in the row).

In Formula B, only the **X component of the formula is highlighted**, indicating that the W, Y, and Z components do not contribute to the formula value.

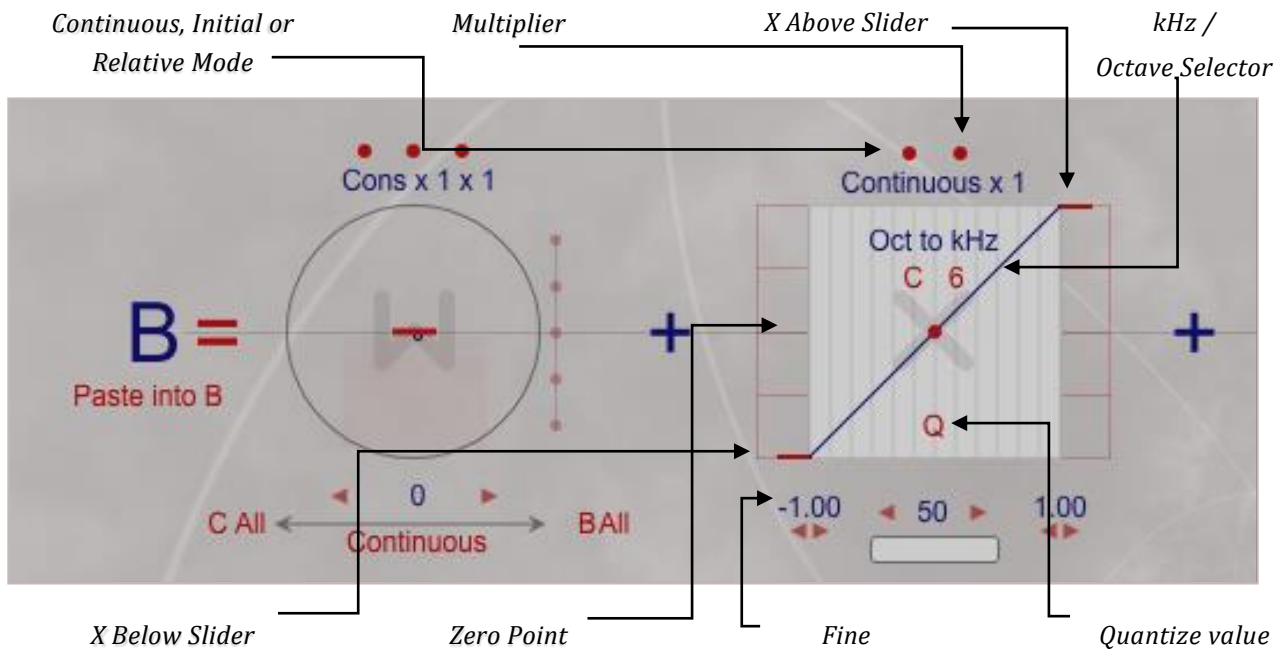

The **X Mode** is “Continuous” which means that the fingerboard’s X position is being tracked and updated continuously as long as the finger is in contact with the surface. Other less common X Modes are “Initial” (which means that the X value is sampled and held when the finger first comes in contact with the surface) or “Relative” (which means that the X value is relative to the position at which finger first comes in contact with the surface).

The X component has a **Zero Point**, which is the position on the Continuum surface where the X component of the formula has an output of zero for “Continuous” and “Initial” mode. In a pitch sense, this is where Middle C will be.

To the left of the Zero Point, X is scaled by the **X Below Slider**. To the right of the Zero Point, X is scaled by the **X Above Slider**.

Since the oscillators and filters in the EaganMatrix are controlled in kHz units, **kHz** is normally selected. Alternatively, **Octaves** can be selected for octave units.

In this preset, Formula B causes the frequency of Oscillator 2 to track the Continuum surface one octave above concert pitch, due to the setting of the Zero Point at C6 instead of the default concert pitch setting of C5.

## 4.2. Tutorial 2: Resonant Drum

Open the Preset file "Resonant Drum Tutorial.mid". This is a copy of the EaganMatrix preset sound "Resonant Drum", one of the more complex EaganMatrix sounds, in particular with some of the formulas used for the Biquad Bank:

The screenshot shows the EaganMatrix software interface. A box labeled 'Formula C' is highlighted, containing a matrix of formula points. A red dot indicates the selected formula point. Below the matrix, the formula is displayed as  $C = W + X + Y + Z$ . The parameters are:  $W = 0.18$ ,  $X_{\text{Below}} = 0.07$ ,  $X_{\text{Above}} = 0.06$ ,  $Y$  (squared), and  $Z$  (square root). The Biquad Bank 1 settings are also visible, showing various filter parameters and transfer functions.

Select Formula C in the matrix, as shown above. In this Resonant Drum sound, Formula C is used for subtle control of the bandwidth parameter of the Biquad Bank. All four components (W, X, Y and Z) are used in Formula C to control the amount of ringing of the resonant drum. It uses a careful blend of X (left/right), Y (front/back), and Z (pressure) finger movements to influence the width of the filters in Biquad Bank 1. Lower value output from this formula will cause narrower bandwidths in the biquad bandpass filters, resulting in more sustained resonance in the sound.

The W component is a constant, adding 0.18 to the overall formula. Try modifying the formula by increasing the value of **W Slider** from 0.18 to 0.28. The overall effect will be a more muted drum because of the overall increase in the formula output value, resulting in wider bandwidths. Return the W Slider to 0.18.

The X component has **Octave** units. The X component smoothly increases by 0.07 each octave below middle C, and by 0.06 each octave above middle C. This X component ensures that the farther the finger's pitch is from middle C, the more the drum resonance is muted.

The Y component uses a squared transfer function, with *lower* values as Y *increases*. This reverse-Y effect is achieved by making the **Y Range Minimum** larger than the **Y Range Maximum**.

The Z component is of particular interest. Having the **Z Range Maximum** set at 0.14 is what makes the drum sound ring when played with a sharp attack and release, and muted when played held down. This mimics the behavior of an acoustic drumhead, which mutes with sustained harder contact.

Select the formula used to control the frequency of the Biquad Bank, Formula I, as shown below.

Select this matrix point to show Formula I

*X Component multiplied by  
W Component*

*X Quantize is 12*

Formula I is used for control of the centre frequencies of the biquad bandpass filters. The **X Quantize** is 12 to make the pitch is the same within each octave from C to C. It then jumps an octave in the next octave range of the playing surface. This simulates having a separate virtual tuned drum within each octave span of the Continuum. The X component is multiplied by the W component. The **W Modifier** is control “ix127”. This allows for global pitch of the sound to be set using the control. The version of control assignment is the “times 127” variety, which allows for equal divisions using 7-bit values (e.g., doubling the control setting will cause an exact doubling in pitch).

Select the formula used to control the frequency spread of the Biquad Bank, Formula B.

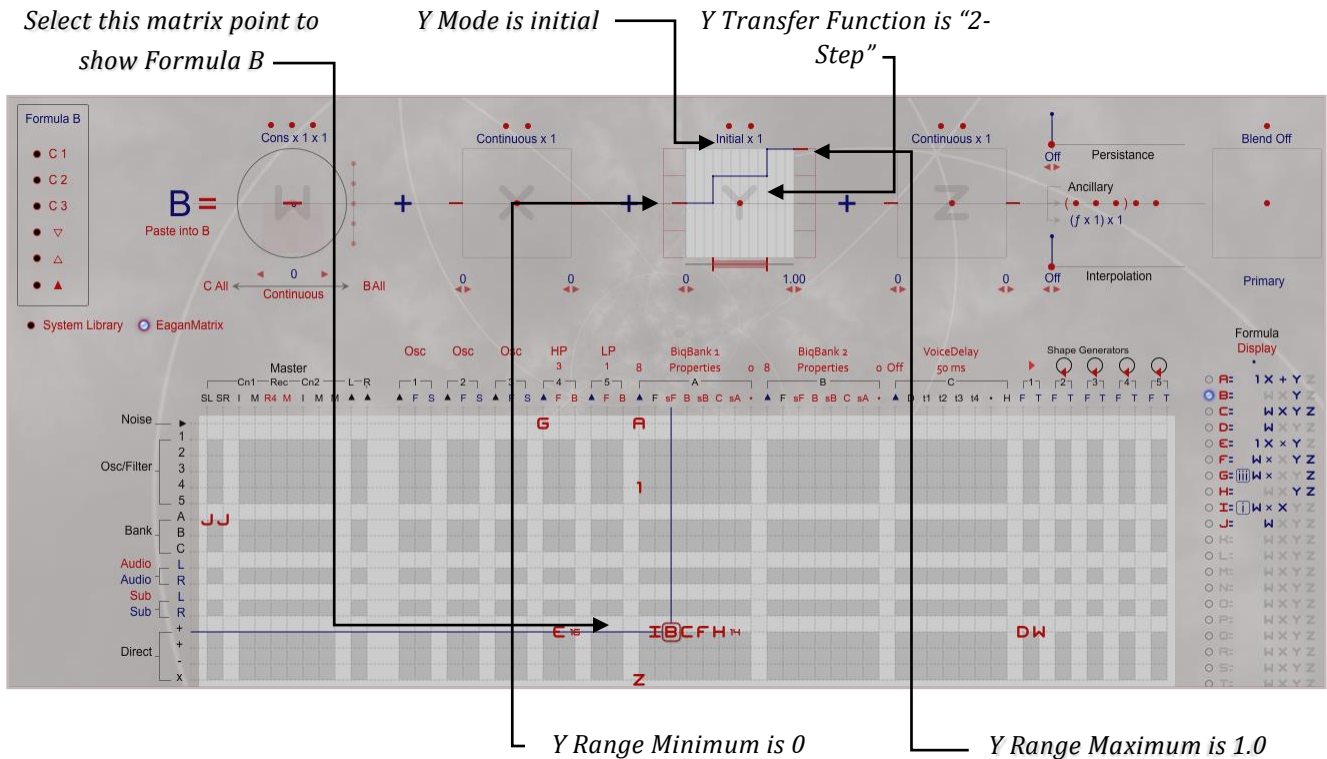

Only the Y component is used in this formula. The **Y Mode** is set for “Initial” (abbreviated Ini), so it reads only the initial Y value (the value of Y when the finger first touches the playing surface). The 2-step transfer function is selected; this means the Y component has only three values: front, middle, and back, set at 0, 0.5, and 1 respectively. The middle value is exactly halfway between the front and back values. This Y component creates three apparent shifts to the pitch of the drum sound due to the varying spreads of the frequency centers of the filters in the biquad bank. As the finger continues to move on the surface, this value will not change due to the “Initial” mode setting.

Load up the “Resonant Drum 1” from the System Presets Percussion category and explore the other formulas to deduce their influences on the sonic output of the Resonant Drum. Note that most presets contain very useful descriptions that often go into some detail on modelling techniques and also give useful suggestions on modifications that may be of interest.



For this preset investigate at how both a direct (single cycle shape generator-based) pulse of noise (formula A) and continuous filtered noise (formula G) are used as inputs to the BiqBank. Disable each (by clicking and then pressing the space bar) and see how that affects the sound. Play up and down on Y with sharp attacks, then disable formula H and see how Center mode focus (which is Y and Z based here) affects the sound.

## 5. EaganMatrix Sources Reference

Any EaganMatrix Source (matrix row) may be multiplied by a formula and added to an EaganMatrix Destination (matrix column) by placing the formula at the intersection of the row and column.

### 5.1. Sources

Source		Description of Matrix Row for each Source
Noise		Noise audio out.
Osc/ Filter	1	Audio from oscillator/filter 1. Possible oscillators are DSF, Integrated DSF, Jenny OSC and Phase Generators. Possible filters are Low Pass, High Pass, Band Pass, Low Pass Shelf, High Pass Shelf, Notch, All Pass, Single Pole Low Pass and Single Pole High Pass. There is also a Noise from Seed available and a Signal Multiplier. These are described in Section 6.2.
	2	Audio out from oscillator/filter 2.
	3	Audio out from oscillator/filter 3.
	4	Audio out from oscillator/filter 4.
	5	Audio out from oscillator/filter 5.
Bank	A	Audio from multipurpose Bank A. One of the following may be selected for Bank A: a biquad bandpass filter bank (BiqBank Scaled Resonances, BiqGraph Mode Amplitude Graphs, or BiqMouth Vocal Formants), a generator bank (SineBank Sine Oscillators, SineSpray Sine Grains, or WaveBank Wave Generators), or a Manipulator (HarMan Harmonic Manipulator, or ModMan Modal Manipulator). An Additive (synthesis) Bank and Kinetic (spring) Modelling Bank are also available. See Section 7.
	B	A second multipurpose bank like Bank A, giving access to a second set of modules identical to those in Bank A. In addition, the CVC Control Voltage module is available in Bank B.
	C	A third multipurpose bank. One of the following may be selected for Bank C: a delay (VoiceDelay, SummedDelay, MicroDelay, or FormulaDelay), or modules from Bank B. Bank C can use select modules from Bank B when Bank B has different (and compatible) modules selected (SineSpray, WaveBank, HarMan and CVC).
Audio (In)	L	<p>Note: This option does not apply for the ContinuuMini.</p> <p>The audio from the left channel of the AES3 input into the Continuum or Analog Audio input on the EaganMatrix module. Alternatively, this row can be Tap 1 from VoiceDelay or SummedDelay (Bank C), or a mono sum of the stereo AES3 input. In a CEE Combination Preset, this row can supply DSP 3 with the left channel output or the mono sum from the other DSPs - allowing for post-processing on DSP 3 (the latter feature is available on all "Slim" model Continuum Fingerboard and expanded half-size and full-size Continuums with at least 3x DSP processing).</p> <p>Note: The Audio input feeds into ALL voices. If you use a constant in the column, and only a constant, it's essentially opening up all the voices to pass through at that constant level. So the more voices, the more copies. The result is that as you increase polyphony, the volume of the AES output will increase as more copies are output. Also, a formula might be a constant, in which case it will act as such (W set as constant).</p>



Source		Description of Matrix Row for each Source
		<p>If programming the EaganMatrix module Audio In processor functions, typically polyphony should be set to 1 to avoid unexpected effects of voice copying at higher polyphony levels.</p> <p>Normally you would put a formula here which is voice specific. Same thing would happen if you fed an oscillator into the SL/SR columns with a constant. You would hear all the oscillators ringing, each at its last received pitch level. It's an interesting effect.</p>
	R	<p>Note: This option does not apply for the ContinuuMini.</p> <p>The audio from the right channel of the AES3 input into the Continuum or Analog audio input on the EaganMatrix module. Alternatively, this row can be Tap 2 from VoiceDelay or SummedDelay, or a mono sum of Tap 1 and Tap 2 from the Delay. In a CEE Combination Preset, this row can supply DSP 3 with the right channel output from the other DSPs — allowing for post-processing on DSP 3.</p>
Sub	L	<p>The audio submix from the left channel of the Master (SL column after saturation, Convolutions and Recirculator). Alternatively, this row can be Tap 3 from VoiceDelay or SummedDelay, or a mono sum of the Master's submix. In a CEE Combination Preset, this row can supply DSP 3 with the left channel output or the mono sum from the other DSPs — for post-processing on DSP3.</p> <p>Note: CCE Combination Presets and associated DSP processing options do not apply to the ContinuuMini or EaganMatrix Module and require at least 3x DSP processing.</p>
	R	<p>The audio submix from the right channel of the Master (SR column after saturation, Convolutions and Recirculator). Alternatively, this row can be Tap 4 from VoiceDelay or SummedDelay, or a mono sum of Tap 3 and Tap 4. In a CEE Combination Preset, this row can supply DSP 3 with the right channel output from the other DSPs — for post-processing on DSP 3.</p> <p>Note: CCE Combination Presets and associated DSP processing options do not apply to the ContinuuMini or EaganMatrix Module and require at least 3x DSP processing.</p>

## 5.2. Direct Sources

Direct	+	Adds formulas or constants directly into a matrix column (without multiplying by an audio signal).
	+	Adds formulas or constants directly into a matrix column.
	-	Subtracts formulas or constants directly from a matrix column.
	x	Multiplies a matrix column by a formula or constant.

## 6. EganMatrix Destinations Reference

Any EganMatrix Source (matrix row) may be multiplied by a formula and added to an EganMatrix Destination (matrix column) by placing the formula at the intersection of the row and column.

### 6.1. Master

Master (Output Section of the EganMatrix)			
Master	SL	Left	Audio input into the left channel of the Master Section, to be processed by the Master's soft saturation, Convolution, Recirculator, and second Convolution. The Master Section processes the stereo audio sum of all voices.
	SR	Right	Audio input into the right channel of the Master Section, to be processed by the Master's soft saturation, Convolution, Recirculator, and second Convolution. The Master Section processes the stereo audio sum of all voices.
Cnv1	I	Interp	A value in the range 0 to 3. Controls an interpolation between four Convolution responses. Select the responses, as well as a length and tune value (spectral shift) for each response, in the Convolution area below the matrix. Responses available include: <i>Wood, Metal, Fiber, Waterphone, Waterphone2, Autoharp, Autoharp2, Guitar</i> and <i>Snap</i> . Currently the user can not add Convolutions of their own. This applies to pre-Recirculator Convolution.  Note: Formulas affecting convolution do not consider the playing surface (X, Y and Z components) with the exception of the Touch Area when that is used to control convolution parameters.
	M	Mix	Dry/wet mix of the pre-Recirculator Convolution output, 0 = dry, 1 = 100% wet, .5 = 50% wet/dry, etc.
Recirc	R1	R1	Each of the two Recirc matrix columns contributes to a Recirculator (reverb/echo) control: R1, R2, R3, R4, or Mix. The control is selectable by clicking on the column's heading. The column value (scaled 0..1) will be added to the corresponding Recirculator Control Dial value (cc20..cc24 scaled 0..127; see Continuum User Guide).  The first Recirc column defaults to "R4", which is the time control for all the Recirculator algorithms.  The second Recirc column defaults to "M", the dry/wet mix of the Recirculator output (0 = dry, 1 = 100% wet, .5 = 50% wet/dry, etc.). The Default is 0 (100% dry = Recirculator Off)  Note: Formulas affecting the recirculator do not consider the playing surface (X, Y and Z components) with the exception of the Touch Area when that is used to control recirculator parameters.
	R2	R2	
	R3	R3	
	R4	R4 (Time)	
	M	Mix	
Cnv2	I	Interp	A value in the range 0 to 3. Controls an interpolation between four Convolution responses. Select the responses, as well as a length and tune value (spectral shift) for each response, in the Convolution area below the matrix. This applies to post-Recirculator Convolution.

Master (Output Section of the EaganMatrix)			
	M	Mix	Dry/wet mix of the post-Recirculator Convolution output, 0 = dry (off), 1 = 100% wet, .5 = 50% wet/dry, etc.
Out	M	Mix	A value in the range 0 to 1. Controls the final mix: SL SR processed by Convolutions and Recirculator (100% = value 0), and unprocessed L R (100% = value 1).
Master	L	Left	Input into left channel of the Master. This input is not processed by saturation, Convolutions, and Recirculator.
	R	Right	Input into right channel of the Master. This input is not processed by saturation, Convolutions, and Recirculator.

**Notes for Master Section:**

In the Master Section, columns SL, SR, L, and R, are evaluated independently for each voice. The formulaic output for all other Master Section columns is based on the Touch Area and constants.

The Master produces a stereo **submix** as follows:

Stereo sum (SL, SR) from all voices → Saturation Waveshaper  
 → Pre-Recirculator Convolution → Recirculator → Post-Recirculator Convolution → Submix

The Master's submix is fed back into the matrix on the **Sub L** and **Sub R** matrix rows, for optional further processing.

The Master's **final mix** is controlled by the Master's rightmost M column. For the final mix, the submix is mixed with the sum of L and R from all voices. This final mix is scaled by the Gain dial and sent to the Continuum Fingerboard's headphone and AES3 outputs (Note: AES processing does not apply for the ContinuuMini). In the Slim model it will also be sent to the L/R Analog outputs.

For saturation and overload effects, use large formula values (typically larger than 1) in the Master SL and SR columns, and use the Gain dial to attenuate the final output level. The Master Section will waveshape high amplitude audio from the SL and SR columns, or soft clip if Via Limiter (see Ancillary Operator Mechanism) is selected in the Master SL and SR formulas. Waveshaping and clipping in the Master Section can be completely avoided by using small formula values (typically less than 1) in the Master SL and SR columns, and increasing the Gain dial to compensate. Also, no waveshaping is done on the Master L and R columns. Technical detail: No loss of accuracy results from scaling values up or down, because the EaganMatrix is based on floating-point computations.

Tilt Eq and Compressor functions available in the Editor and through Midi control are not programmed directly into the EaganMatrix Master section.

Note: Formulas affecting the Master Section, with the exception of SL/SR and L/R columns do not consider the playing surface (X, Y and Z components) with the exception of the Touch Area.

**Examples of Master Section usage in EaganMatrix System Presets:**

*Sine Wave*: Very simple sound; Oscillator 1 is connected to Master Section's SL and SR columns using predefined Formula Z.

*Pulsar*: Combination of Bank A and Filter 1 outputs are summed in the Master Section.

*Sputnik's Dream*: Uses formulas to control the Master Section's Recirculator and post-Recirculator Convolution.

*Left Hand Filter Echo*: Makes use of the L and R columns of the Master Section to bypass the Master Section's Recirculator and Convolutions.

*Electric Guitar Saturated*: Uses Saturation with SL/SR values > 1 (adjusted by a control).

As an example, consider two Oscillators are created, one outputs to SL/SR and the other outputs to LR both using the standard Z pressure function. Depending on the submix of SL and LR, determined by the rightmost M column in the master section, you can create a mix of what is output with the Master section applied (Saturation, Convolution and Recirculation) and what is output without Master Section processing:

Basic Use of Submix (SL/SR and L/R Output Mix)

The image shows three screenshots of a software interface, each representing a different submix setting (M). Each screenshot shows a grid of controls for various audio processing stages: Noise, Osc/Filter, Bank (A, B, C), Audio (L, R), Sub (L, R), and Direct (+, -, x). The 'Master' section at the top includes controls for Cn1, Rec, Cn2, L-R, and F S. The 'Osc' section at the top right includes two 'Osc' labels. In each screenshot, a vertical bar highlights the 'M' column, and a red circle highlights the value in the 'M' column. The 'F S' column has 'X' and 'Xeo' markers.

- Submix M = 0**: 100% SL/SR output. Only OSC1 will be heard. With Master Section Applied (Saturation, Convolution & Recirculation/Reverb).
- Submix M = 0.5**: 50% SL/SR + 50% LR output. OSC1 & OSC2 mix will be heard. With Master Section Saturation Convolution and Reverb Only Applied to OSC1 Output.
- Submix M = 1.0**: 100% LR output. Only OSC2 will be heard. With No Master Section Applied (No Reverb, Convolution, Saturation).

6.2. Oscillators / Filters / Multipliers

6.2.1 DSF Oscillators

Oscillators			
Osc1	▲	Audio Input	Oscillator 1 phase modulation input, 0 = 0 radians, 1 = 2π radians. Use this for modulation or waveshaping (if the F column is left blank), or as a seed value for the "Noise from Seed" option if it is in that case triggered through the T Column. Leave this blank for an oscillator without modulation. Does not apply to Jenny Oscillator selection.
	F	Frequency	Oscillator 1 or Phase Generator 1 frequency control, in kHz. Leave this blank for a waveshaper if a DSF oscillator is selected, and for Noise from Seed. Does not apply to Jenny Oscillator selection.

Oscillators			
	<b>S</b>	Spectral Balance	Oscillator 1 spectral balance, 0 for pure sine, > 0 to add harmonics, 1 for max harmonic amplitudes. For waveshaping, this provides a continuous real-time control of the nonlinear filter's transfer function.  If Phase Generator is Selected, S is the Frequency Spread in Hz for the "Sum of 7 Phases" option. IT is not used if any other Phase Generator option is selected.
	<b>Bx</b>	Bandwidth Multiplier	If Jenny Oscillator (JOsc) is selected (see below). Accelerates the resonance decay rate (has no effect when "No Resonance Decay" is selected (Decay options: Linear, Steep, Gentle and None). See Jenny Oscillator below.
	<b>Fx</b>	Frequency Multiplier	If Jenny Oscillator (JOsc) is selected (see below). Operates in relation to the master oscillator frequency (nearest DSF, Integrated DSF or Phase oscillator to the left of the JOsc). See Jenny Oscillator below.
	<b>F</b>	Spread	If a Phase Generator is selected, this is the Frequency Spread (in Hz) for the oscillator's 7 phase generators.
	<b>T</b>	Trigger	If Noise from Seed is selected, a transition from T≤0 to T>0 triggers use of the ▲ input as a new random noise seed value.
Osc2..5			Four more oscillators like Oscillator 1.  Note: Since the Jenny Oscillator operates in conjunction with the nearest non-Jenny master oscillator to its left in the matrix, a max of 4 Jenny Oscillators can be defined though in practice only one or two would typically be used.

**Notes for Oscillators:**

1. The EaganMatrix has five 3-column Oscillator/Filter/Multiplier slots; each of the five is configurable as Oscillator or MultiMode Filter or Signal Multiplier.
2. When the Audio Input (phase modulation) and Spectral Balance (S) are both equal to zero, this functions as a pure sine wave source at frequency F. The oscillator is most efficient when the S column is left blank due to optimization of the sine algorithm.
3. An oscillator can act as a waveshaper when audio is routed into the Audio Input (phase), and the F (frequency) column is blank (0 kHz). The S column can be used to dynamically alter the waveshaping function, making for unique nonlinear filtering effects.
4. Select Normal DSF for harmonic amplitudes that decrease with harmonic number in an exponential fashion determined by the S column. Select Integrated DSF for harmonic amplitudes proportional to the inverse of harmonic number; S=0.8 has the same harmonic amplitudes as a sawtooth. (Refer to the graphs below for Normal DSF and Integrated DSF waveforms.) Select Phase Generator to output the oscillator's 7 internal phase generators, with the S column controlling frequency spread in Hz. The Phase Generator (in "Sum of 7" mode) is equivalent to a sum of 7 non-bandlimited sawtooth waveforms (for bandlimited saws, see "WaveBank"). Select Noise from Seed for a random noise generator based on seed value. If the same seed value is used for each note (a constant in the ▲ input column and W in the T column), the sequence of random numbers will be the same for each note.

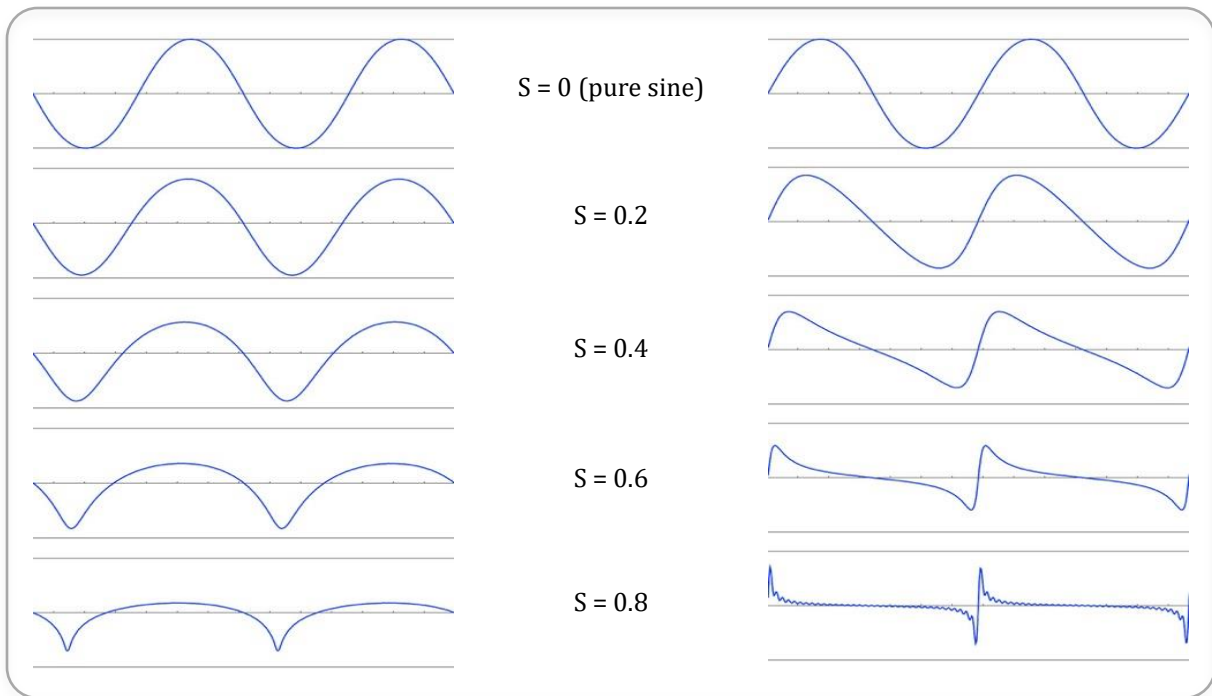

**Integrated DSF and Normal (non-integrated) DSF Oscillator Waveforms for different S values**

*Note: The 0.8 integrated waveform has harmonic amplitudes equal to a sawtooth (6 dB/octave rolloff).*

**Examples of Oscillator usage in EaganMatrix System Presets:**

*FM Bells:* FM synthesis technique.

*Harmonic Break:* Waveshaping using the phase input of an Oscillator.

*Meccano:* Changes the frequency of an Oscillator with a Sample-and-Hold (Formula A's sample-and-hold of Formula B is triggered by SG1).

*Sawz:* Combines two bandlimited Oscillators (with Integrated DSF) and a non-bandlimited Oscillator (with a Phase Generator) to create an ensemble sound over the whole pitch range, without audible aliasing.

*Mini Shepard:* Crossfades two Oscillators to create the illusion of an ever-rising pitch.

*Pad Tie:* Changes the spectrum of Oscillators dynamically (Formula E in the S column).

*TriMod:* A combination of frequency modulation and waveshaping.

**6.2.2 Multimode Filters**

Multimode Filters			
1 (LPF, HPF, BPF, LPS, HPS,	▲	Audio Input	Filter audio input. Possible 2-pole filters (12 dB/octave cutoff slope) are Low Pass, High Pass, Band Pass, Low Pass Shelf, High Pass Shelf, Notch, and All Pass. Possible 1-pole (6 dB/octave) filters are Low Pass and High Pass.

Multimode Filters			
NOF, APF, LP1, HP1)	F	Cutoff Frequency	Filter frequency control, in kHz.
	B	Bandwidth (not LP1, HP1)	Filter bandwidth control, smaller values narrow the bandwidth and increase resonance.
	T	MicroDelay Tap (only LP1)	A MicroDelay tap, used in Feedback Delay Networks. The first MicroDelay tap is available in the first Multi-Mode filter, the second tap in the second filter, etc. up to the fourth filter (as only 4 MicroDelay taps are available).
2..5			Four more filters like Multimode Filter 1.

**Notes for Multimode Filters:**

1. The EaganMatrix has five 3-column Oscillator/Filter/Multiplier slots; each of the five is configurable as Oscillator or MultiMode Filter or Signal Multiplier.
2. A red numeral underneath the filter type can be selected to control filter cascade. For MultiMode filters, **Cascade** choices are 1, 2, 3, or 4, corresponding to 12, 24, 36, or 48 dB/octave cutoff slope for 2-pole filters, and 6, 12, 18, or 24 dB/octave cutoff slope for 1-pole filters. Technical detail: When cascading 2-pole filters to create 4, 6, and 8 pole filters, the bandwidths are adjusted to  $B^{1/2}$ ,  $B^{1/3}$ , and  $B^{1/4}$  so that the same perceived cutoff frequency is maintained at each cascade value. See example filter responses below.

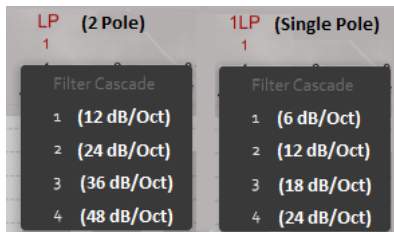

3. The Cutoff "F" or Bandwidth "B" options are selectable to control filter update rate (Normal or Extreme).

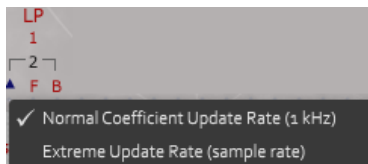

Select **Normal** (default) to recompute filter coefficients once per millisecond, based on F and B column values. Select **Extreme** to recompute filter coefficients every sample interval. If the F or B columns have audio-rate signals, Extreme

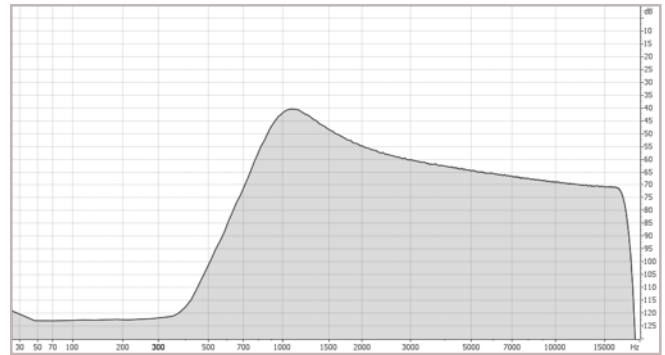
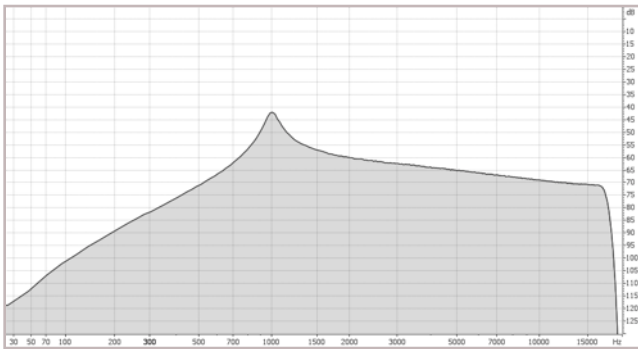

should be selected.

*Resonant Low Pass filter responses for  $F = 1.0$ ,  $B = 0.1$ , cascade = 1 (left image) and cascade = 4 (right image). In both images, reducing  $B$  will make a narrower and more pronounced resonance at the cutoff frequency; increasing  $B$  ( $0.1 < B < 1$ ) will make a wider and shallower resonance;  $B = 1$  will result in no resonance, and, as  $B$  is increased beyond 1, the slope near the cutoff frequency will be reduced, making for a gradual filter.*

**Low Pass Filter Comparison:**

As an example, here is a spectral plot comparison of noise from seed fed into the LPF option at a cutoff of 100 Hz, with successive Bandwidths of 0.01, 0.1 and 1.0 for each of the four cascade options. As filter bandwidth increases the cutoff resonance becomes less distinct and as cascade increases the slope of the cutoff becomes more compressed. Note that actual output will change a bit based on the settings of the plotting plugin used (perhaps enhancing peaks and smoothing out a bit more), but the overall comparison on how bandwidth and cascading affect the filter output between the cases is clear.

EaganMatrix Low Pass Filter Comparison

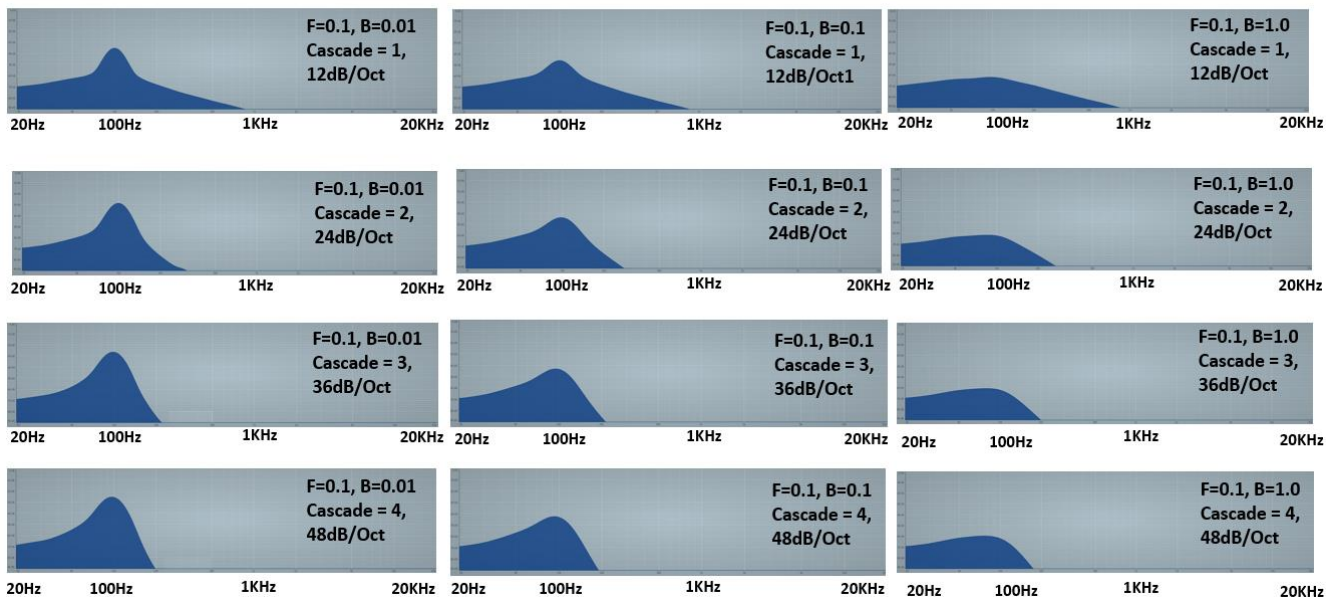

**High Pass Filter Comparison:**

A similar comparison for HPF is presented below. In this case the cutoff slope obviously is applied to the low end frequencies.



EaganMatrix High Pass Filter Comparison

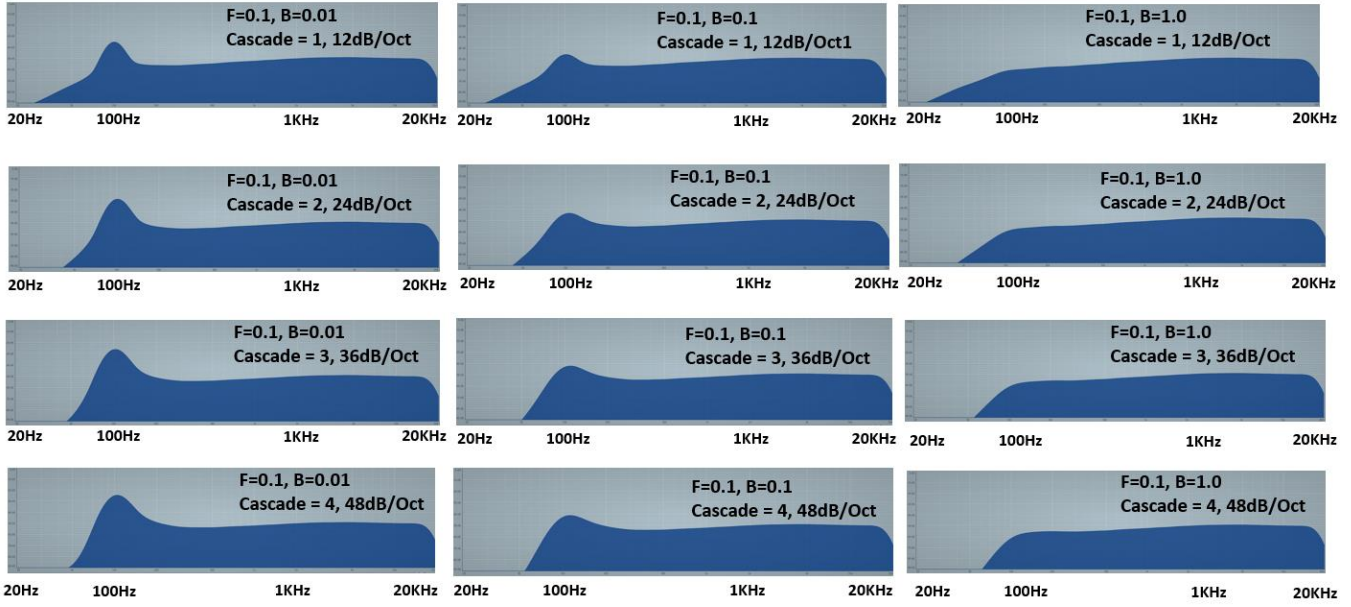

**Band Pass Filter Comparison:**

Comparing the same treatment of sending noise through a bandpass filter at the same values, you can see the cascade slopes are applied to both sides of the cutoff resonance which maps to bandwidth as expected.

EaganMatrix Band Pass Filter Comparison

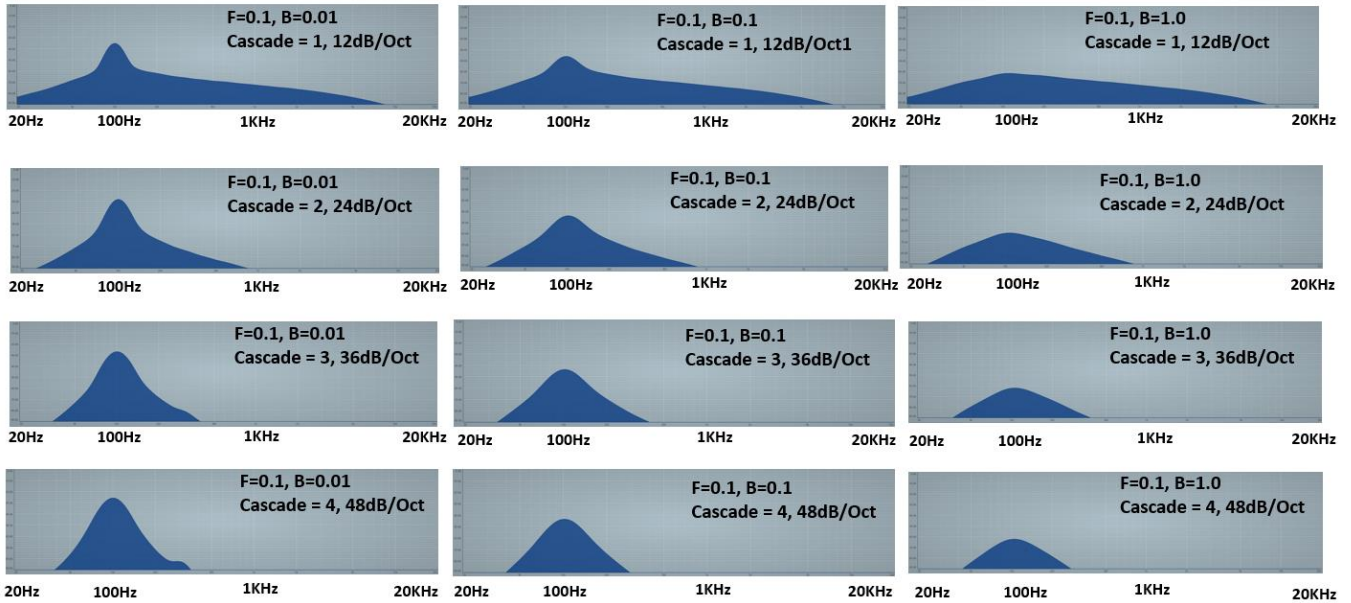

**Band Reject (Notch) Filter Comparison:**

As would be expected the Band Reject (Notch) filter works opposite from the Band Pass filter, opening up a notch of greater amplitude as cascade increases and width as bandwidth increases. Here the cutoff frequency is changed from 100Hz to 500Hz to better center the notch in the spectral view.

EaganMatrix Band Reject (Notch) Filter Comparison

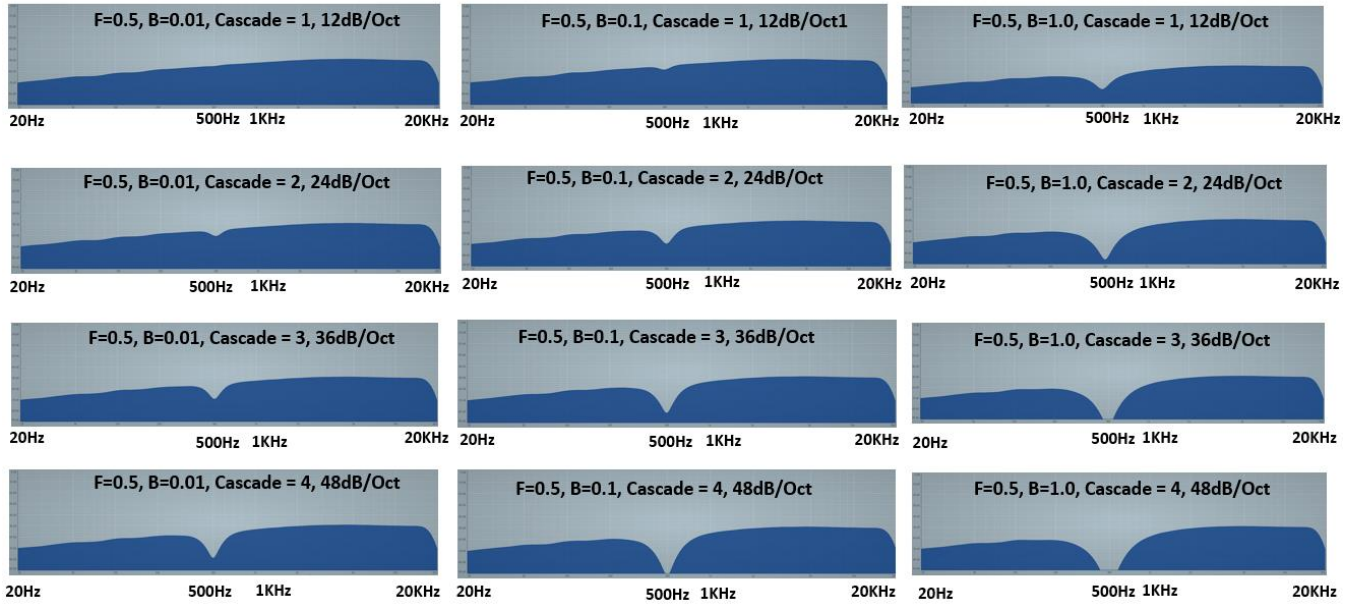

**Low Pass Filter Type Comparison:**

The following is a comparison of noise sent though the three different low pass filter types with cutoff frequency set to 500H, for each of the four cascade options at bandwidth set to 0.1(for LPF and sLPF).

EaganMatrix Low Pass Filter Type Comparison

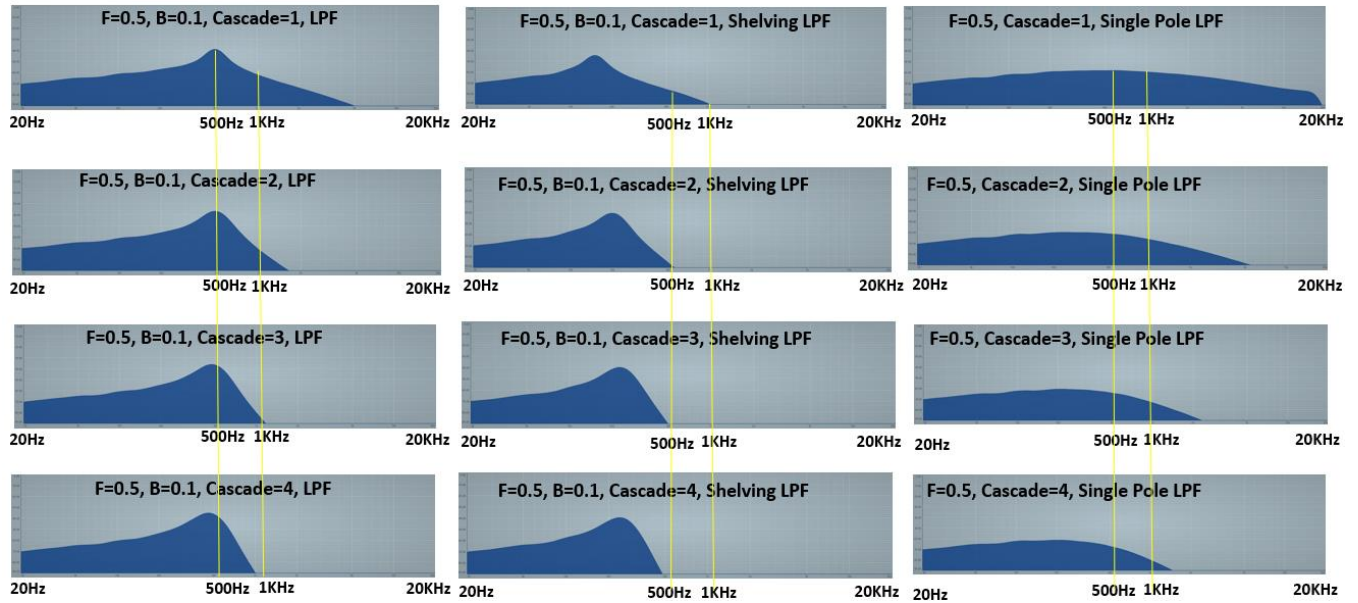

**High Pass Filter Type Comparison:**

The following is a comparison of noise sent though the three different high pass filter types with cutoff frequency set to 500H, for each of the four cascade options at bandwidth set to 0.1 (for HPF and sHPF).

EaganMatrix High Pass Filter Type Comparison

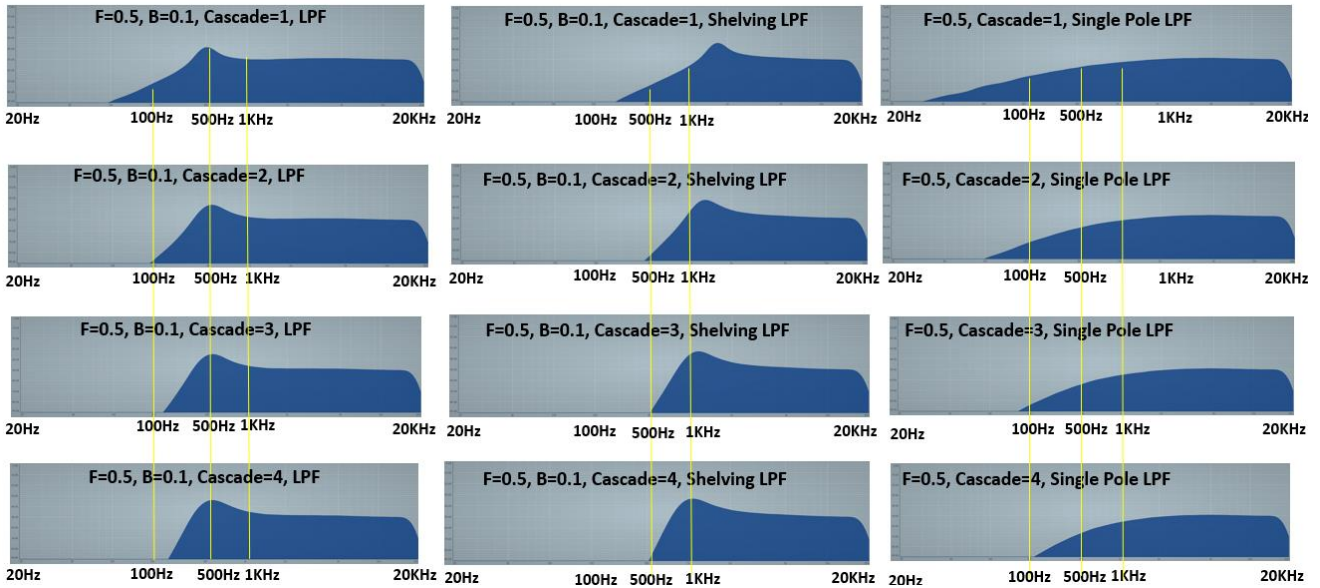

**Examples of Multimode Filter usage in EaganMatrix System Presets:**

*Ping Pong*: Extensive filtering using two Band Pass filters.

*Geiger Insects*: An emulation of imaginary insects, using High Pass filters controlled by a cyclical Shape Generator.

*Meccano*: Changes the frequency of an Oscillator with a Sample-and-Hold.

*Mini Shepard Breathing*: Low Pass Shelf filter on noise.

*Mutate Looper*: Uses a Low Pass Filter to modify the output of a delay.

*Razor Loops*: Extensive filtering using two All Pass filters.

*Spit Tube*: Modulates the cutoff frequency of a filter at audio rates, with “Extreme” selected for the filter.

*Swept Delay*: Uses High Pass Shelf filters to modulate a sustained delay loop.

*Three Sines*: Uses a fixed-frequency Low Pass filter to reduce possible aliasing artifacts.

*VlnVlaCelBass*: A High Pass filter adds high frequency energy into the sound, based on finger pressure.

Signal Multipliers			
Mul1	▲	Audio Input	Signal Multiplier 1 - first input. Will be multiplied by the second input.
	▲	Audio Input	Signal Multiplier 1 - second input. Will be multiplied by the first input.
Mul2..5			Four more Signal Multipliers like Signal Multiplier 1.

**Notes for Signal Multipliers:**

1. The EaganMatrix has five 3-column Oscillator/Filter/Multiplier slots; each of the five is configurable as Oscillator or MultiMode Filter or Signal Multiplier.
2. The Signal Multiplier is an amplitude multiplier. It can be used to smoothly amplitude modulate anything from sub audio rate into audio rate, as its multiplication happens at sample rate, instead of control rate, like a shape generator. It is a main building block for Ring Modulation.

**Examples of Signal Multiplier usage in EaganMatrix System Presets:**

*Crossmod1/2/3:* Uses signal multiplication of two DSF OSCs modified in various ways between the three versions.

*Zazipad:* Uses signal multiplication of an Phase Generator OSC.

**6.2.3 Phase Generators**

Select Phase Generator (in default “Sum of 7” mode) to output the oscillator's 7 internal phase generators, with the S column controlling frequency spread in Hz.

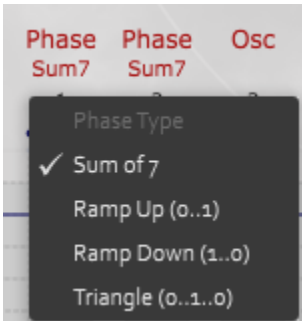

When selecting a Phase Generator (“Phase”) selection from the OSC/Filter bank. The options available are:

**Sum of 7:** This is the default Phase Generator (previous “Expose Phase” option) which is equivalent to a sum of 7 non-bandlimited sawtooth waveforms (for bandlimited saws, see “WaveBank”)

**Ramp Up (0..1):** This is a “phase ramp” which means a non-bandlimited ramp, used for phase calculations. Using one of these feeding into the phase modulation input of an Oscillator is equivalent to the “normal” use of the Oscillator alone and entering values in the F column.

**Ramp Down (1..0):** This is the same as 0..1, but convenient in some situations. 1..0 is the same function that post-multiplies within a Jennie oscillator when “Sharp” Resonance Decay Contour is selected.

**Triangle (0..1..0):** This is a triangle which again can be useful in phase computations – not band-limited.

## 6.2.5 Jenny Oscillators

The “Jenny Oscillator” (pronounced “Genie”) is intended to model and in some ways extend the oscillator design of Georges Jenny that was used in the Ondioline, invented in 1941. The Eagan Matrix “Jenny Oscillator” is not a simulation of the Ondioline circuit but attempts to implement what Jenny was describing as a specification of this oscillator which was not possible to exactly create at the time. Jenny’s method predates Casio’s “Phase Distortion” synthesis and IRCAM’s “Chant Synthesis”.

The Eagan Matrix Jenny Oscillator is not an oscillator in and of itself. It is used in conjunction with a Master Oscillator – the nearest DSF oscillator, Integrated DSF oscillator or Phase Generator to the left of the Jenny Oscillator in the matrix. It will produce no sound if defined in the matrix and sent directly to outputs without a Master Oscillator present. Fundamentally it provides a way to have a set of synced oscillators (a bit similar to Hard-Sync, but with additional features). While the Master Oscillator is most often output with one or more associated Jenny Oscillators, the Jenny Oscillator can be output on its own, but still requires the Master Oscillator for phase reference of course.

Each Jenny Oscillator utilizes the phase of the Master Oscillator in two ways:

1. Applies a frequency multiplier to the Master’s phase before passing it to the DSF (to create a “resonance” frequency, usually  $\geq 4.0$  times the Master’s Frequency. It multiplies the master phase by the Fx column, to make a higher frequency. This makes the “resonance frequency”, and the Jenny uses that to produce its waveform. Example: If Fx is 5, then the Jenny goes through  $5 \times 360$  degrees in the time that the master oscillator goes through 360 degrees. The phase units used inside the EaganMatrix have 0=zero degrees) and 1=360 degrees. So in the time that the Master oscillator goes 0 to 1 in internal phase value, the Jenny (in this example) goes 0 to 5 in internal phase value.
2. Inverts the Master’s phase before multiplying by the DSF output (a decay envelope for the resonance)

The “Jenny Oscillator” contains a few novel extensions to Jenny’s original method. The controls available in the matrix are:

- **Bandwidth Multiplier (Bx)** (a real value greater or equal to 1.0). 1 = normal bandwidth. Values greater than 1 increase bandwidth accelerating the Jenny Oscillator’s resonance decay rate. This has no effect when set to zero (left blank in the matrix). If  $Bx=1$ , the Jenny computes  $1 - \text{MasterPhase}$  (making a ramp function that decays over one master oscillator period) and post-multiplies the Jenny’s own output by that - making a non-bandlimited linear ramp decay on the resonance. The resonance completely decays within one period of the Master, always. That is a faster decay than many decays in nature, but fast resonance decay is inherent in the Jenny. If  $Bx > 1$ , then the decay is even faster than one period (faster decay makes for a wider bandwidth effect); the Jenny computes  $\text{MAX}(0, 1 - Bx * \text{MasterPhase})$  for the post-multiply. Note: You can use Bx values between 0 and 1 but in that case you will be adding in a sinusoid (resonance) that does not decay within one fundamental period, adding a discontinuity.
- **Frequency Multiplier (Fx)** - achieves narrower band resonances than possible with Jenny’s original method and facilitates longer-than-one-fundamental-period resonance decays. 1 = same resonance frequency as the Master’s frequency. Values greater than 1 increase the resonance frequency. Values 5-10 are common. Not applied if set to zero or left blank in matrix (but normally it is set).
- **Shape / Spectral Balance (S)**. When set to zero creates sine resonance. When set greater than zero adds harmonics (up to maximum value of 1.0). This is similar to the S column in the DSF oscillator. Note that while the Jenny Oscillator gets its phase from the master, not its spectral balance. That is set on the Jenny Osc.
- **Resonance Decay Contours** (Sharp [Band un-Limited], Smooth, Hann or None). Selected with text under the “JOsc” heading. If you choose a different resonance decay contour (smooth or Hann), then you get rid of the sharp edges on the resonance decay function (the ramp), and can reduce aliasing out of the Jenny as a result

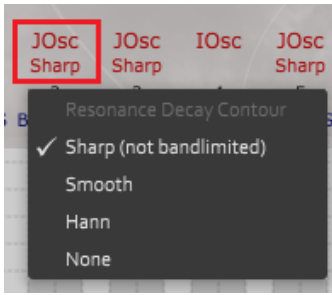

**None - No Resonance Decay Contour (Default)**

This creates a discontinuous waveform unless Fx is an integer. This intended for use in a sound designs where the Jenny oscillator feeds into an external Signal Multiplier that multiplies by the Master oscillator's output. Since the Master oscillator's output begins and ends at zero, the discontinuity is removed. Note that even with the external multiply, the other Resonance Decay Contour choices are also useful, as they produce a variety of timbres.

**Sharp Resonance Decay Contour**

This creates a linear decay over one fundamental period of the Jenny's Master oscillator. This linear decay is derived from the Master oscillator's phase function directly. The Master oscillator's phase is a ramp that goes from 0 to 1 and is sharp – not smoothed – not bandlimited. With the Sharp Resonance Decay Contour and B=1, the Jenny oscillator is post-multiplied by 1-MasterOscillatorPhase; this implements a decay in a way similar to Georges Jenny's method. For B>1, the decay is faster, the post-multiply is MAX(0, 1-B\*MasterOscillatorPhase). When using the Sharp decay contour, the post-multiply is not bandlimited, so that can be a source of noticeable aliasing. In particular, it can result an audible time-varying pulsing (due to heavy aliasing) at particular frequencies. (Jenny did not have these aliasing problems, since he was working in the analog domain!)

For example, if the Jenny Osc is set to a Sine (S=0), Bx=1, and the resonance decay shape is set to "Sharp (not bandlimited)", an amplitude decay ramping shape from max to min will be applied to the Jenny waveform over one phase period, creating a different waveform (which has a rather sharp phase transition between periods). The sharp phase transition creates a harmonic content rich in partials, but aliasing may also be present as the Sharp option is not band limited.

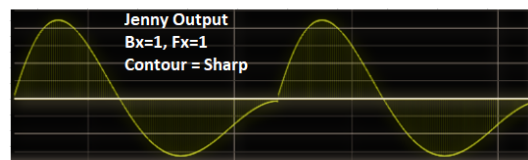
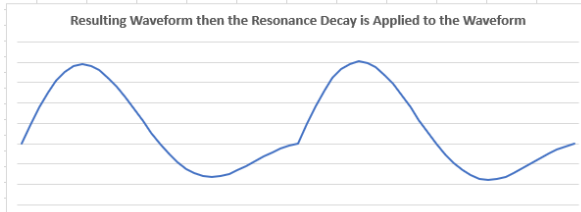
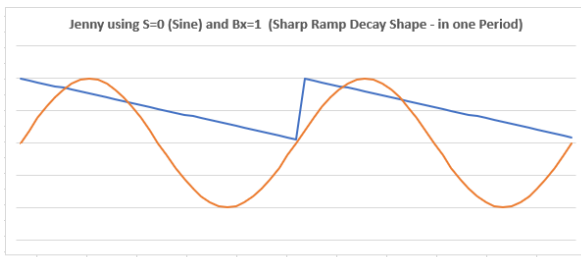

**Smooth Resonance Decay Contour**

This creates a bandlimited linear decay contour over one fundamental period of the Jenny's Master oscillator assuming  $Bx=1$ . This is a smoothed version of the Sharp Resonance Decay Contour. It has a similar-but-different sound when compared to the Sharp contour. It will not have the audible time-varying pulsing that is present at certain pitches using the Sharp contour, but aliasing still occurs when the Jenny oscillator explicitly creates resonances at too high frequencies (harmonics beyond the half sample rate). Avoid this source of aliasing by reducing  $F_x$  (closer to 1), reducing  $B$  (closing to 1), reducing  $S$  (closer to 0), and/or fading out the Jenny oscillator when its Master oscillator is playing in the higher pitch range.

**Hann Resonance Decay Contour**

This creates a maximally smooth contour over one fundamental period of the Jenny's Master oscillator assuming  $Bx=1$ . The frequency of the decay interval (the Master oscillator's frequency) will be much less audible in the Jenny's output compared to the Smooth contour. Like the Smooth contour, aliasing still occurs when the Jenny oscillator explicitly creates resonances at too high frequencies (harmonics beyond the half sample rate). Avoid this source of aliasing by reducing  $F_x$  (closer to 1), reducing  $B$  (closing to 1), reducing  $S$  (closer to 0), and/or fading out the Jenny oscillator when its Master oscillator is playing in the higher pitch range. The Hann decay tends to smooth out the waveform and reduce harmonic content.

**Resonance Decay Comparisons**

The three different decay contours will affect the waveform shape and associated harmonic content. For example lets use a Master Sine Osc with three Jenny Oscs each set to one of the three contour shapes (looking at the output of each Jenny Osc). The Jenny Osc is set to  $Bx=1$  (Normal bandwidth) and  $F_x=1$  (Master Osc phase/frequency).

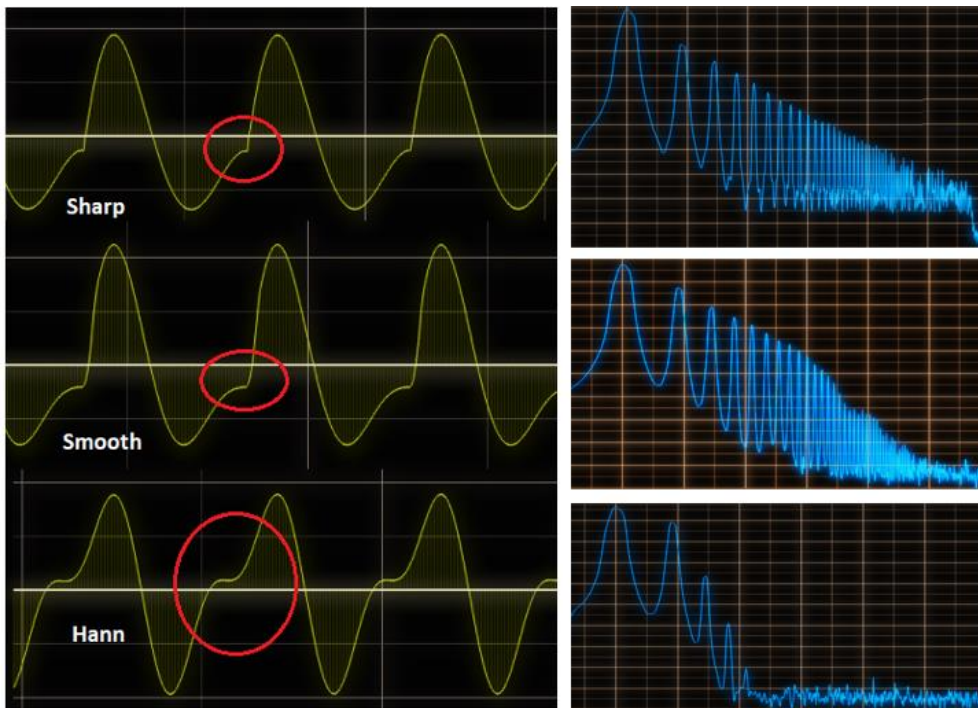

The sharp phase transitions in the Sharp and to lesser extent smooth contours create a spectrum rich in harmonics (note there is some DC offset in the examples not in the raw output). A sawtooth-like sound will result. The Hann shape smooths out the waveform and reduces harmonic complexity. This is very noticeable in this case where  $Bx=1$  and  $F_x=1$ . At higher, and perhaps fractional frequency multiples, the waveform may be a lot more complex in all

cases. For example with the Jenny set to  $Bx=2$  and  $Fx=3.45$ , even the Hann shape will create a very rich harmonic result. Jenny oscillators are excellent for creating a wide variety of complex, reedy timbres.

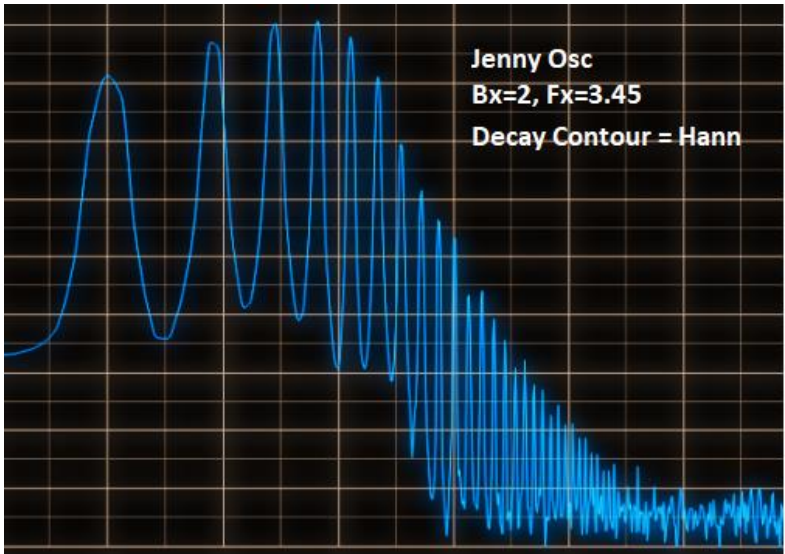

Compare this to the same setting using the Sharp contour option. The sound is similar but a bit harsher. It all comes down to simply experimenting with the decay contours to get a sound you like, or perhaps use more than one Jenny Oscillator and mix them.

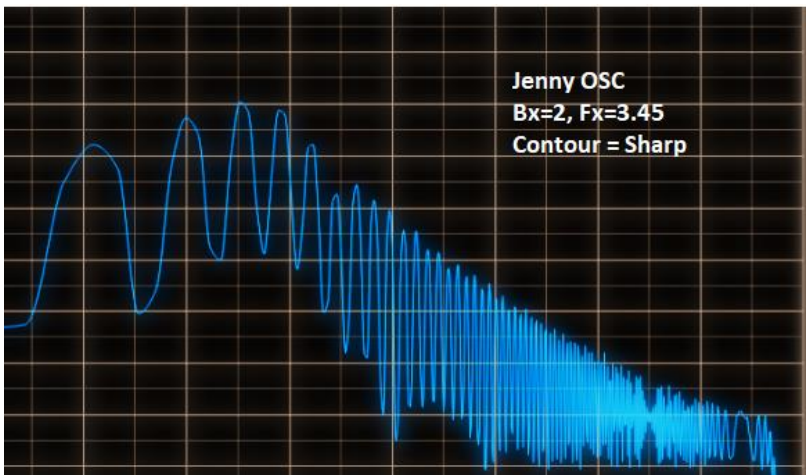

### **Multiple Jenny OSCs**

More than one Jenny oscillator can be used in the matrix associated with a Master. Most commonly, you would have one “regular” oscillator, with two Jenny oscillators to the right of it. That allows for two separate resonances to control providing many nice sonic possibilities. In practice, you normally will not need to define more than two Jenny Oscillators unless you are after a special effect.



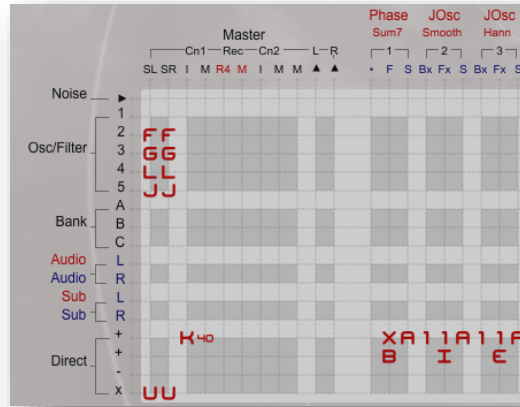

*Two Jenny Oscillators associated with one Master Oscillator*

Of course you can define two separate Masters each with their own Jenny Osc (or possibly 2). In this case a DSF oscillator Master is associated with two Jenny Oscillators (one with Hann and the other will Smooth contours). Then a second Master, this tie an Integrated DSF Osc is associated with a Sharp contoured Jenny Osc.

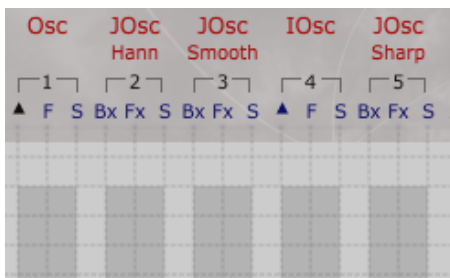

When using the Jenny Oscillator, you may experience aliasing in the higher registers. Even though the Hann and Smooth decay shapes are Band Limited, they are not of infinite bandwidth. If you are generating frequency components above the half sample rate with a bandlimited decay on a high frequency fundamental, aliasing can result since the highest components of that bandlimited decay are still above the half sample rate.

The most bandlimited response is the Hann. So for high notes you have to design the sound to prefer Hann over the other decays, and for very high notes, you have to tone down the Jenny oscillator outputs (since they are above half sample rate).

When a decay on a Jenny oscillator is bandlimited, it is nontrivial to know exactly how bandlimited. If the frequency multiplier in the Jenny oscillator is small numbers (like 2-4) you still get a pretty wideband result; but the higher the frequency multiplier, the better the band limiting will function (more of the resonant frequency periods in each fundamental period). You can think of the decay same as a window function. Hann is best (maximally smooth), next is the Smooth decay and then the unsmoothed linear ramp decay.

### 6.3. Multipurpose Banks: BiqBank (Modal Physical Model)

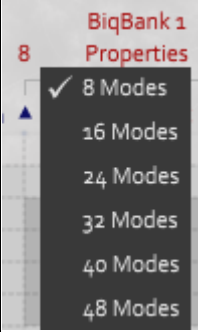
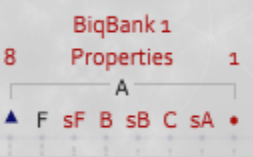
Multipurpose Banks: BiqBank			
This table defines BiqBank operations as defined in the matrix. See BiqBank Properties for fixed settings.			
BiqBank 1		<p>Excitation input for all modes of the modal physical model. The modes (modal resonances) are created using biquad bandpass filters. Select number of modes by clicking selectable red text above this matrix column.</p> 	
	F	Frequency	Frequency (in kHz) for the first mode (first resonance).
	<p><b>Note:</b> Up to six of the following parameters can be selected as BiqBank matrix columns. Select the desired column's function by clicking on the column's heading (i.e. sF). In general, do not duplicate column selections. Columns default to sF, sF, B, C, sA (and an unused column that can also be selected – red dot). Any column can be set to any of the values which when defined are added to the identical Properties set in the BiqBank Properties panel (except Spectral Peak Resonance Frequency which is multiplied by the associated property). If not defined as a BiqBank matrix column, the fixed value defined in the property control is used as is. Use of Spectra Peaks requires the Amp Headroom toggle to be set to 24dB.</p> 		
	sF	Frequency Spread	Linear Mode Spacing. Determines the linear frequency spread of modes. 1 for harmonic spacing of modes, >1 stretched spacing and <1 compressed spacing. This value gets added to the fixed Spread control property. If you select sF as a column, it is recommended not to also add a qF column (though it is possible and the two will be added together for the final output).
	qF	Quadratic Frequency Spread	Squared Mode Spacing. Determines the nonlinear frequency spread of modes. 0 for no non-linearity, >0 for offsets proportional to mode-number-squared. If you select qF as a column it is not recommended to also add an sF column (though it is possible and the two will be added together for the final output if you want to experiment). This value gets added to the Non-Linear Spread Property.
B	Bandwidth	Mode bandwidth control, smaller values increase resonance. This value gets added to the BW control property.	

**Multipurpose Banks: BiqBank**

This table defines BiqBank operations as defined in the matrix. See BiqBank Properties for fixed settings.

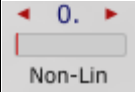
R	(Mode) Amplitude Ratio	Even/Odd Mode Attenuation. Less than zero suppresses amplitudes of the odd-number modes. Greater than zero suppresses amplitudes of even-number modes. Default = 0, normal mode attenuation. (Example: can model open/closed pipe harmonics). This value gets added to the fixed Even/Odd control property.
C	Centre (of Focus)	Modal Model Centre control. 0 means first mode is centre, 1 means 8th mode is centre. Larger values can be used if model has more modes (click led above excitation input column); A value of 1.5 means the 12 <sup>th</sup> mode is the center. A value of 6 means the 48 <sup>th</sup> mode (maximum) is the center, etc. This value gets added to the fixed Centre control property.
sB	Bandwidth Spread	Linear Bandwidth Spacing. If sB>0 a linear increase of bandwidth farther from Centre will occur (see below). If sB <0 a decrease will occur. This value gets added to the fixed BW Δ control property. If you add an sB column, it recommended not to also add a qB column (though the two can be used in conjunction with each other for experimentation). The Non-Linear control will be added to the sB column if it is defined.
qB	Quadratic Bandwidth	Non-Linear Bandwidth Spacing. qB specifies non-linear increase-from-Center-(value squared) as bandwidth offset. If qB>0 a quadratic increase in bandwidth farther from Centre will occur (see below). If qB <0 a decrease will occur. If you add a qB column it is not recommended add a sB column (though the two can be used in conjunction with each other for experimentation). This value gets added to the Non-Linear Property set above the Bandwidth Spread Property. 
sA	Amplitude Spread	Mode amplitude spread. 0 means no amplitude scaling of modes, >0 means reduced amplitude of modes farther from Centre (C column). This value gets added to the fixed Amp Δ control property – computed as dB/Mode or dB/Octave depending on the property setting.
1F	Spectral Peak Frequency	Spectral Peak Resonance 1 Frequency (See Spectral Peak control below)
2F	Spectral Peak Frequency	Spectral Peak Resonance 2 Frequency (See Spectral Peak control below)
3F	Spectral Peak Frequency	Spectral Peak Resonance 3 Frequency (See Spectral Peak control below)
1B	Spectral Peak Bandwidth	Spectral Peak Resonance 1 Bandwidth (See Spectral Peak control below)
2B	Spectral Peak Bandwidth	Spectral Peak Resonance 2 Bandwidth (See Spectral Peak control below)
3B	Spectral Peak Bandwidth	Spectral Peak Resonance 3 Bandwidth (See Spectral Peak control below)
1A	Spectral Peak Amplitude	Spectral Peak Resonance 1 Amplitude (See Spectral Peak control below)

<b>Multipurpose Banks: BiqBank</b>			
This table defines BiqBank operations as defined in the matrix. See BiqBank Properties for fixed settings.			
	2A	Spectral Peak Amplitude	Spectral Peak Resonance 2 Amplitude (See Spectral Peak control below)
	3A	Spectral Peak Amplitude	Spectral Peak Resonance 3 Amplitude (See Spectral Peak control below)
<b>2</b>			A second filter bank like BiqBank 1, available in Bank B.

**BiqBank Properties Panel:**

Select the red “Properties” text under the BiqBank label to display the BiqBank Properties panel in the Control Panel area. The Properties selections work in conjunction with the BiqBank column settings. The Properties are unique for each of the two possible BiqBanks.

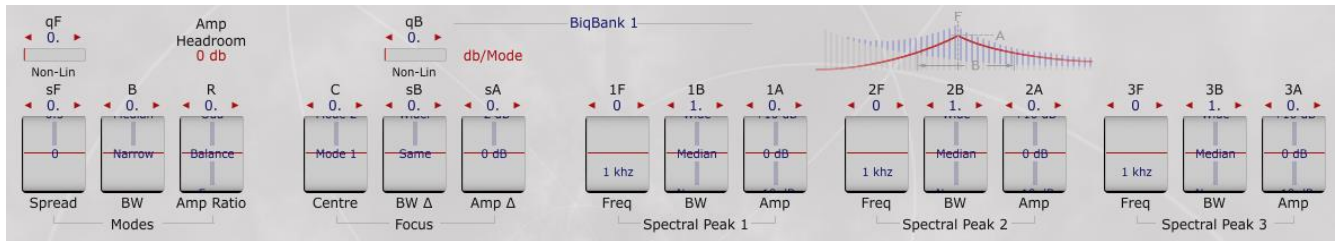

The BiqBank Properties controls are divided into three sets of controls that act on the BiqBank: Modes, Centre Focus and Spectral Peaks as follows:

**Modes Control:**

- **Spread (sF)** (Range: 0.0 .. 2.0, Default: 0.0) – This Property determines the linear frequency spread of the modes. A value of 1 sets normal harmonic spacing. A value greater than 1 stretches the harmonic spacing of modes. A value less than 1 compresses the harmonic spacing of modes. Frequency spread control that adds to sF or qF, if defined in the matrix. A non-linear adjustment is available above the Spread Property.

A non-Linear control (qF) above the Spread property can be applied. The effect of the non-linear controls is scaled by mode number squared. This is also programmable as an offset in the matrix.



- **BW (B)** (Range: 0.0 .. 2.0, Default: 0.0/Narrow) – This property determines the mode bandwidth. A total bandwidth value of 1 is most common. Values smaller than 1 increase the resonance of each mode and values greater than 1 increase the resonance of each mode. The Bandwidth Property adds to B column if present.
- **Amp Ratio (R)** (Range -1.0 .. 1.0, Default: 0.0/Neutral) – This Property determines the Even/Odd mode amplitude ratio control. It defaults Neutral (zero). Less than zero suppresses amplitudes of the odd-number modes. Greater than zero suppresses amplitudes of even-number modes. This value will be added to the E column in the matrix if it is defined.

**Centre of Focus Control:**

- **Centre (C)** (Range: 0.0 .. 1.0, Default: 0.0/Mode1) – This Property determines the Center-of-Focus of the modes defined. Zero means the first mode is centre (most common). A value of 1 means the eighth mode is the center. The Centre control can only be set to a maximum of mode 8. If more modes are defined, the center must be adjusted past eight through additional offsets in the matrix (though unless the mode spacing is adjusted there should not be a need to increase past 8 in most cases). A value of 1.5 means the 12<sup>th</sup> mode is the center. A value of 6 means the 48<sup>th</sup> mode (maximum) is the center, etc. This value will be added to the C column if set in the matrix
- **BW Δ (sB)** (Range 0.0 .. 2.0, Default: 0.0/Same) – This Property determines the bandwidth spread factor. A value of zero means each mode has the same bandwidth. A value greater than zero means modes farther from the Centre-of-Focus have increased bandwidth. A value less than zero means modes farther from the Centre-of-Focus has decreased bandwidth. It is added to whatever is defined in the sB (linear) and qB (non-linear) columns. A non-linear adjustment is available above the property that will be added as an offset to the current value. If a negative value is desired it must be offset in the matrix as the **BW Δ** control's range has a zero minimum. This value will be added to the sB or qB column if set in the matrix.

A non-Linear control above the Bandwidth Delta property will be applied if set.



- **Amp. Δ (sA)** (Range 0.0 .. 5.0 / 0dB .. -30dB, Default: 0.0/0 dB) – This Property determines the Mode Amplitude Spread. A value of zero means the Centre-of-Focus does not affect mode amplitudes. A value greater than zero means reduced amplitude of modes farther from the Centre. Values are proportional to dB/Octave or dB/Mode, selectable with the toggle text control above the **Amp. Δ** setting.



The sA column will be added to this value if it is defined in the matrix.

**Spectral Peak Control:**

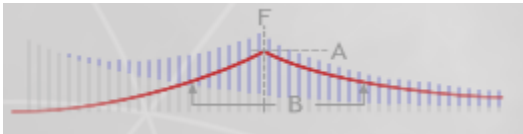

The spectral peaks are three configurable resonances, like formants of your mouth defined by a Frequency, Bandwidth and Amplitude. A mode near the spectral peak can have a lot of amplitude added in, and a mode far from the spectral peak has less amplitude added in. This is indicated by the picture of a “generic” sound above the spectral peak controls; that “generic” sound has modes equally spaced in frequency and a Focus set at the fundamental (so it has decaying amplitudes of modes); the spectral peak adds into those amplitudes.

Note: If using spectral peaks you must set the Amp Headroom control to 24 dB.

- **Spectral Peak 1: Freq (1F)** (Range: 1kHz or 8.7Hz .. 12543.9 Hz / C#0 .. G10, Default: 0.0/1kHz) – This property determines the centre frequency of the first of three possible Spectral Peaks that can be defined. This value will be multiplied by the 1F column in the matrix if it is defined. The Spectral Peak will have greatest influence on amplitudes of modes nearest this frequency. If the default 1 kHz selection in BiqBank Properties is not changed, the resulting value computed by multiplying by the 1F matrix column will be in kHz, otherwise the resulting value will be the control value set times the 1F matrix column if present. If no 1F column is present or the formula in that column equals zero and the default 1kH value is set, no spectral peak will be defined.

- **Spectral Peak 1: BW (1B)** (Range: 0.0 .. 2.0, Default: 1.0/Median) – This property determines the bandwidth of the first Spectral Peak. This value is added to the 1B column if defined in the matrix. A value of 1 means the Spectral Peak's contributions to mode amplitudes decrease 6 dB/octave from the centre frequency of the Spectral Peak. A value of 2 means 3 dB/octave, 0.5 means 12 dB/octave, etc. No peak will be created if this value is not changed from its default zero value and no 1B column is defined in the matrix. Also this parameter has no effect if the frequency of the peak is set to zero.
- **Spectral Peak 1: Amp (1A)** (Range 0.0 .. 5.0, Default: 0.0) – This property determines the amplitude of the first Spectral Peak. A value of zero means the spectral peak makes no contribution to the mode amplitudes. Larger values correspond to larger contribution to mode amplitudes (as long as the other two properties are set to create a Spectral Peak. This value will be added to the value in the 1A column if it is defined in the matrix.
- Spectral Peak 2: Freq (2F). - Second Spectral Peak that operates identically to Peak 1 Freq.
- Spectral Peak 2: BW (2B) - Second Spectral Peak that operates identically to Peak 1 BW
- Spectral Peak 2: Amp (2A) - Second Spectral Peak that operates identically to Peak 1Amp.
- Spectral Peak 3: Freq (3F) - Third Spectral Peak that operates identically to Peak 1 Freq
- Spectral Peak 3: BW (3B) - Third Spectral Peak that operates identically to Peak 1 BW
- Spectral Peak 3: Amp (3A) Third Spectral Peak that operates identically to Peak 1Amp.

**Amp Headroom Toggle** (0dB / 24 dB).

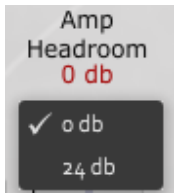

This is useful if you want the centre of focus to have less effect compared to the Spectral Peaks. Sometimes the focus effects on bandwidths of modes will overwhelm the Spectral Peaks. Keep in mind the amplitude of a mode is only one determining factor of how loud the mode is. The other major factor is the bandwidth of the mode. If the mode resonates a lot it can be loud even if its amplitude is small.

*Note: You must set Amp Headroom to 24dB if you are using the Spectral Peak controls and/or associated or matrix programming.*

**Deflation Limit:**



The deflation limit applies to biquad filters, especially in modal filters (like BiqBank). If internal state values (values in the delays inside a biquad) exceed some limit (set by the deflation limit) the EaganMatrix will automatically increase the bandwidth on the biquad, thereby reducing the amount of energy being retained (fed back) inside the biquad and reducing the magnitude of the internal state values ("deflating"). A wide bandwidth bandpass filter will not resonate (it

"deflates") like a narrow bandwidth ("high Q") bandpass filter. The bandwidth returns to normal after internal values "calm down".

It only works well in some situations. It is supposed to protect against pain-level oscillations inside biquads that have a super-narrow bandwidth. It works ok in situations where players have control over the bandwidth, and there are certain things they "should not do" -- like when you play feedback electric guitar in the Real World, you will get a pain-level experience unless you are really careful; that walking-on-the-edge danger is an important part of playing feedback electric guitar. ... But in most situations it is best if the preset can be designed to avoid too-narrow bandwidth and not require deflation.

**Notes for BiqBank:**

BiqBank, BiqGraph, BiqMouth, and ModMan are four different ways to control the same underlying technology: a set of biquad bandpass filters.

BiqBank provides bandpass filters on an audio-rate input, with filter parameters controlled by the matrix as described in the table above. Each BiqBank may consist of 8, 16, 24, 32, 40, or 48 bandpass filters. The indicator above the first BiqBank matrix column is off for Normal (8 bandpass filters), on for Extended (16, 24, 32, 40, or 48 bandpass filters). Click on the Indicator to change its state.

The Deflation Limit (above the last BiqBank matrix column) avoids excessive buildup of energy inside the BiqBank but has no effect under normal playing conditions. Set the Deflation Limit to the largest value (between 0 and 7) that does not affect the timbre of the sound. Click on the Deflation Limit to change its value.

**Examples of BiqBank usage in EaganMatrix System Presets:**

*Bouncer:* A narrow bandwidth BiqBank creates a sound like a bouncing tonal object, using noise for the BiqBank's audio input.

*Icicles:* A narrow bandwidth BiqBank creates a glass-like repeating tonal object, using noise for the BiqBank's audio input.

*Golliclock:* Oscillators processed through a BiqBank.

*Marlin Perkins:* A tongue-drum simulation.

*Metal Rainstick:* A wide bandwidth BiqBank creates a breathy repetitive tonal object.

*Model String Wind:* A string and wind simulation, using an Oscillator to waveshape audio data in a BiqBank feedback loop.

*Resonant Drum 1 and 2:* Pitched drum emulations.

*Rub String:* Novel use of the update noise from a formula to resonate within a pair of BiqBanks. To produce the update noise, interpolation has been set to zero in Formula A and Formula F.

**6.4. Multipurpose Banks: BiqGraph (Modal Graphs)**

Multipurpose Banks: BiqGraph			
BiqGraph 1	▲	Excitation Input	Excitation input for all modes of the modal physical model. Select number of modes by clicking led above this matrix column. The modes (modal frequencies, amplitudes, and bandwidths) are controlled by graphs (click 'Graph' above the bank).
	F	Frequency	Frequency (in kHz) for the first mode (first resonance).

Multipurpose Banks: BiqGraph			
	sF	Frequency Spread	1 for harmonic spacing of modes, >1 stretched harmonics, <1 compressed.
	B	Bandwidth	Bandwidth control, smaller values increase mode resonance. Value 1 corresponds to bandwidth 0 dB down (bandwidth equals mode frequency), value 0 is bandwidth -100 dB down.
	sB	Bandwidth Spread	0 means each mode has the same bandwidth, >0 means higher modes have increasing bandwidth, <0 higher modes have decreasing bandwidth.
	1A	1 Graph Scale	Scale factor for 1 Graph, offsetting Mode dB Amplitudes. See below.
	1F		Scale factor for 1 Graph, offsetting Mode % Frequencies. See below.
	2A	2 Graph Scale	Scale factor for 2 Graph, offsetting Mode dB Amplitudes. See below.
2B	Scale factor for 2 Graph, offsetting Mode dB Bandwidth. See below.		
2			A second bank like BiqGraph 1, available in Bank B. When two BiqGraphs are in use, they share the same graph data.

**Notes for BiqGraph:**

BiqBank, BiqGraph, BiqMouth, and ModMan are four different ways to control the same underlying technology: a set of biquad bandpass filters.

BiqGraph is suitable for Modal Physical Modeling. In Modal Modeling terminology, each biquad bandpass filter is called a “mode”. The amplitudes for each mode are computed from dB amplitude values specified in three amplitude graphs. The three graphs are called A Graph (dB amplitude values), 1 Graph (first set of dB amplitude offsets), and 2 Graph (second set of dB amplitude offsets). These graphs are combined under control of matrix columns, resulting in time-varying mode amplitudes, as explained on the next page.

Alternatively, by selecting 1F instead of 1A for the matrix column, the 1 Graph may be used for Scaled % Frequency Offsets. By selecting 2B instead of 2A for the matrix column, the 2 Graph may be used for Scaled dB Bandwidth Offsets.

Each BiqGraph may consist of 8, 16, 24, 32, 40, or 48 modes. The indicator above the first BiqGraph matrix column is off for Normal (8 modes), on for Extended (16, 24, 32, 40, or 48 modes). Click on the Indicator to change its state.

The Deflation Limit (above the last BiqGraph matrix column) avoids excessive buildup of energy inside the BiqGraph but has no effect under normal playing conditions. Set the Deflation Limit to the largest value (between 0 and 7) that does not affect the timbre of the sound. Click on the Deflation Limit to change its value.

**BiqGraph Graphs:**

Click on the “Grph”, “Off1” or “Off2” selectable text to inspect and edit three graphs: Mode Amplitudes (A graph), first set of dB amplitude offsets (1 Graph), and second set of dB amplitude offsets (2 Graph).

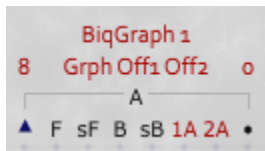

A second method of accessing the BiqGraph graphs is to use the three Control panel options:



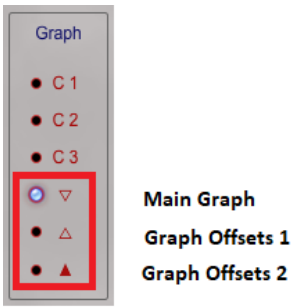

In Slide Wind EM, all three graphs are used to determine mode amplitudes. The dB amplitude of each of the modes is computed from the Mode Amplitude A graph, plus matrix column 1A times the 1 Graph, plus matrix column 2A times the 2 Graph. These are the three graphs for the 8 modes used by the Slide Wind EM sound. Note that the graphs contains sliders to adjust up to 48 modes even though only 8 are defined in this preset. In this case the remaining mode settings have no effect and should be left in their default positions.



The preset “French Sax” uses all 48 modes and thus all mode sliders are considered, though some can still be turned off with minimum (amplitude) or 0 setting (Offsets) if desired. Here are the mode amplitude and offset graphs for this preset:

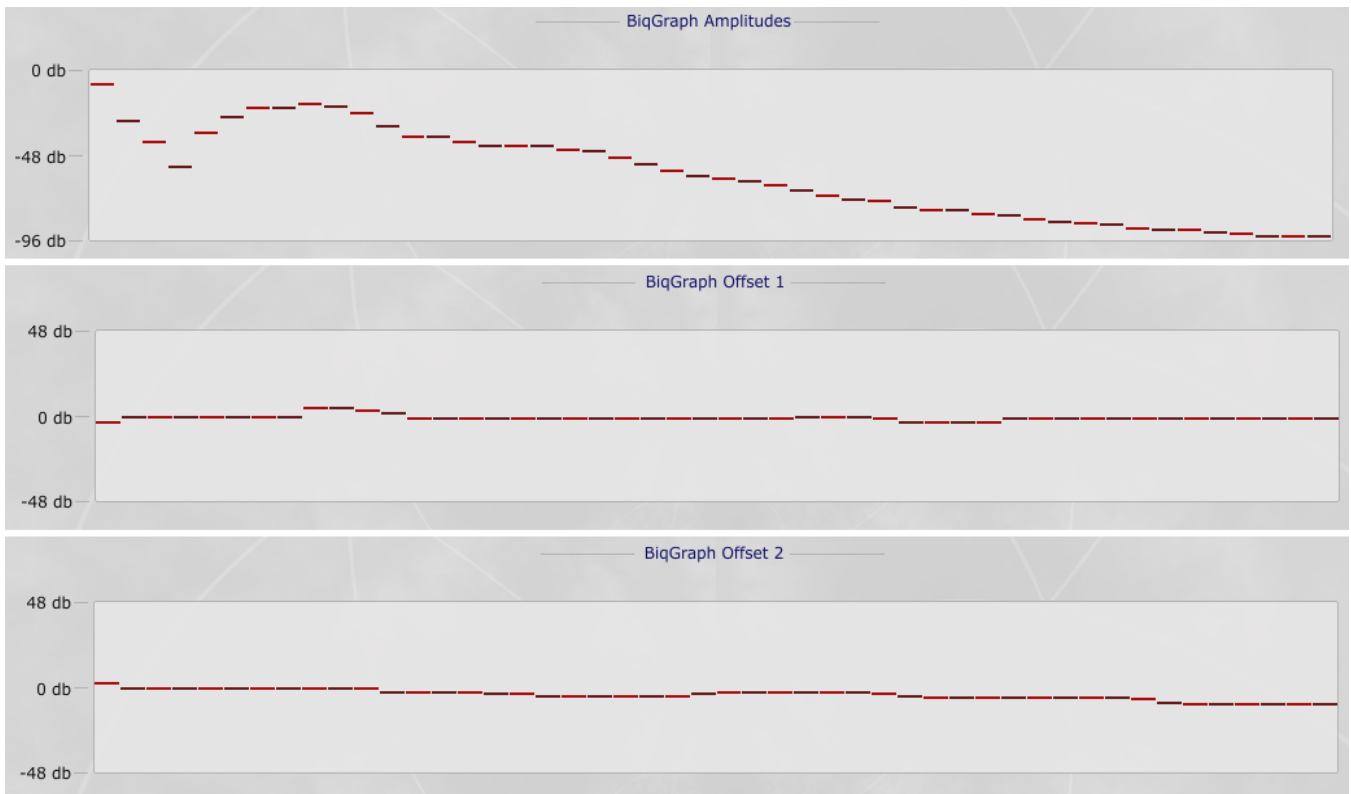

*"French Sax" Preset BiqGraph Settings*

The selectable text above the excitation column is used to set modes greater than the default of 8. Values of 8, 16, 24, 32, 40 and 48 are possible.

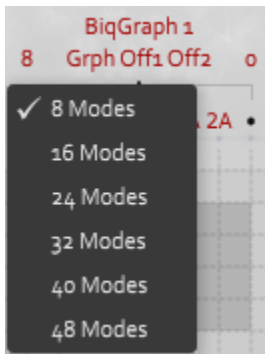

Edit the graphs by clicking with the mouse to change one mode's amplitude or grab the slider and move it with your mouse to the desired value. You can also place your mouse in the desired column and press the left arrow or right arrow to change the mode by +/- 1 dB; or drag the mouse to change the amplitudes of many modes with one motion. If you however on a graph hash, its value will be displayed under the BiqGraph header:

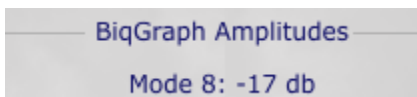

**Examples of BiqGraph usage in EaganMatrix System Presets:**

*French Sax:* Uses an Oscillator as a waveshaper in a BiqGraph feedback loop, to create a cross between a sax and harmonica.

*Slide Wind EM*: Uses an Oscillator as a waveshaper in a BiqGraph feedback loop, to create a changing-body-size wind instrument.

*Space Flute*: Uses an Oscillator as a waveshaper in a BiqGraph feedback loop, to create a flute-like sound with spacey echo repeats.

## 6.5. Multipurpose Banks: BiqMouth (Vocal Formants)

Multipurpose Banks: BiqMouth			
BiqMouth 1	▲	Audio Input	Audio input into the vocal formant filter bank, a series of five biquad formant filters.
	Sh	Mouth Shape	A series of mouth shapes, selectable 0 to 4.8 at 0.1 intervals with smooth morphing between adjacent shapes. See note below for mouth shape listing.
	sF	Frequency Spread	Multiplier on formant frequencies, 1.0 = normal.
	oF	Frequency Offset	Offset on formant frequencies, 0.0 (blank column) = normal.
	sB	Bandwidth Spread	Formant bandwidth multiplier, 1.0 means each formant has default bandwidth, > 1.0 means formants farther from Centre (see below) have increased bandwidth, < 1.0 means formants farther from Centre have decreased bandwidth.
	C	Centre	BiqMouth Centre control, 0 means first formant is centre, 0.625 means last (5th) formant is centre.
	sA	Amplitude Spread	BiqMouth amplitude spread, 0 means no amplitude scaling of formants, > 0 means reduced amplitude of formants farther from Centre.
2			A second bank like BiqMouth 1, available in Bank B.

### Notes for BiqMouth (Vocal Formants):

BiqBank, BiqGraph, BiqMouth, and ModMan are four different ways to control the same underlying technology: a set of biquad bandpass filters.

BiqMouth is suitable for vocal filtering of an audio-rate input. In voice modeling terminology, each biquad bandpass filter is called a “formant”. The matrix columns control the parameters of 5 formants, to simulate a variety of mouth shapes.

Each mouth shape is implemented using 5 vocal formants. Five biquad bandpass filters are set at the appropriate frequencies, amplitudes, and bandwidths to imitate the resonances of the mouth shape.

The Deflation Limit (above the last BiqMouth matrix column) avoids excessive buildup of energy inside the BiqMouth but has no effect under normal playing conditions. Set the Deflation Limit to the largest value (between 0 and 7) that does not affect the timbre of the sound. Click on the Deflation Limit to change its value.

**BiqMouth Mouth Shapes:**

Mouth Shapes	Symbol	Male Primary "Sh" Column Value	Female Primary "Sh" Column Value
Father	ä	0	3.5
Made	ā	0.1	3.6
Food	oō	0.2	3.7
Go	ō	0.3	3.8
Pad	a	0.4	n/a
Merry	e	0.5	3.9
Mud	ə	0.6	n/a

**Mouth Shape Selection Chart:** The table below shows how the same mouth shapes are selectable with several different "Sh" column values. Mouth shapes have been repeated in different combinations to allow for a maximum of adjacent morphing possibilities. Male mouth shapes have "M" prefix, female mouth shapes have "F" prefix. Male mouth shapes are shown with a yellow background and female mouth shapes are shown with a purple background.

Sh Value	0	0.1	0.2	0.3	0.4	0.5	0.6	0.7	0.8	0.9
0	M:ä	M:ā	M:oō	M:ō	M:a	M:e	M:ə	M:ä	M:oō	M:a
1	M:ə	M:ā	M:ō	M:e	M:ä	M:ō	M:ə	M:a	M:ä	M:e
2	M:ā	M:a	M:ə	M:oō	M:e	F:ä	M:ä	F:ā	M:ā	F:oō
3	M:oō	F:ō	M:ō	F:e	M:a	F:ä	F:ā	F:oō	F:ō	F:e
4	F:ä	F:oō	F:e	F:ā	F:ō	F:ä				

**Examples of BiqMouth usage in EaganMatrix System Presets:**

*Larynx Horn:* A vocal-sounding brass instrument.

*Mantra Voice:* A dreamy ambient vocal sound.

*Tibetan Throat Stick:* Vocal formant processing of a harmonic manipulation (HarMan) of data recorded into the VoiceDelay.

## 6.6. Multipurpose Banks: SineBank (Sine Oscillators)

<b>Multipurpose Banks: SineBank</b> This table defines SineBank operations as programmed in the matrix. See SineBank Properties for the Fixed settings.			
SineBank 1	▲	Phase Offset	Phase offset for all SineBank partials. Leave this column blank for normal operation. Other values can be used for phase modulation effects.  The number of Sinebank partials can be changed with the text control above this column from a default of 8 to 32 in steps of 8. <div style="border: 1px solid black; padding: 5px; margin-top: 10px;">                         SineBank 1                          Properties                          8  <input checked="" type="checkbox"/> 8 Partial  <input type="checkbox"/> 16 Partial  <input type="checkbox"/> 24 Partial  <input type="checkbox"/> 32 Partial                     </div>
	F	Frequency	Frequency (in kHz) for the first sine oscillator (fundamental partial) in the SineBank.
	<p><b>Note:</b> Up to six of the following parameters can be selected as SineBank matrix columns. Select the desired column's function by clicking on the column's heading (i.e. sF). In general, do not duplicate column selections. Columns default to sF, E, sP, C, sA (and an unused column that can also be selected – red dot). These values when defined as matrix columns are added to identical Properties set in the BigBank Properties panel (except Spectral Peak Resonance Frequency which is multiplied by the associated property). If not defined as a SineBank matrix column, the fixed value defined in the property control is used as is.</p> <div style="border: 1px solid black; padding: 5px; margin-top: 10px;">                         SineBank 1                          16 Properties                          A                          ▲ F sF E sP C sA •                     </div>		
	sF	Frequency Spread Linear	Determines the linear frequency spread. Use a value of 1 for harmonic spacing of sines, >1 for stretched spacing and <1 for compressed spacing. This column will be added to the SineBank Spread Property, possibly with a Non-Linear adjustment that may be set in SineBank Properties.
	qF	Frequency Spread Non-Linear	Determines the non-linear frequency spread. Use a value of 0 for no non-linearity. Values > 0 create offsets proportional to the partial number squared. This value is added to the Non-Linear control above the Spread Property. <div style="border: 1px solid black; padding: 5px; margin-top: 10px;">                         ◀ 0. ▶  <input type="text" value="0"/>                          Non-Lin                     </div>
B	Bandwidth	Determines the partial bandwidth. A value of 0 is used for pure sine waves. A value > 0 for amplitude modulation of each partial with low frequency noise. This creates a noise band around each partial's frequency. This column is added to the SineBank's BW property.	

**Multipurpose Banks: SineBank**

This table defines SineBank operations as programmed in the matrix. See SineBank Properties for the Fixed settings.

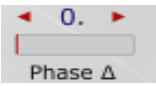
sP	Phase Spread	<p>Determines the Phase spread between partials. A value of 0 means all partials use the same phase offset provided by the bank's first column. A value &gt; 0 is used to scale the phase offset for each partial. This value is added to the Phase Spread Property.</p> 
sB	Bandwidth Spread	<p>Determines the sine partial bandwidth spread factor. A value of zero means each partial has the same amplitude modulation by noise. A value &gt; 0 means partials farther from the Centre-of-Focus have increased noise modulation. A value &lt; 0 means partials farther from the Centre-of-Focus have decreased noise modulation. This value is added to the BWA property.</p>
sA	Amplitude Spread	<p>Determines the sine partial amplitude spread. A value of zero means the Centre-of-Focus does not affect partial amplitudes. A value &gt; 0 means reduced amplitude of partials farther from the Centre. Values are proportional to dB/Octave or dB/Partial (default), selectable in the SineBank Properties. This value will be added to the SineBank's Amp Δ property.</p>
C	Centre	<p>Determines the Centre-of-Focus. A value of 0 means the first sine oscillator (first partial) is centre. This is the most common setting. A value of 1 means the eighth partial is the centre. Larger values can be used if the SineBank has been set to more partials (click above the bank's first column). A value of 1.5 means the 12<sup>th</sup> partial is the centre. A value of 4 means the 32<sup>nd</sup> partial (maximum) is the center. Note that the Centre control only reaches a maximum of 8 partials. Any centre above 8 must therefore be set as an offset in the matrix's C column. This column will be added to the value set in the SineBank Centre property.</p>
R	(Partial) Amp Ratio	<p>Determines the even/odd partial amplitude control. A value &lt; 0 suppresses amplitudes of odd numbered partials. A value &gt; 0 suppresses amplitudes of even numbered partials. A value of 0 does not affect the amplitudes. This value is added to the Even/Odd Sinebank Property.</p>
1F	Spectral Peak Frequency	Spectral Peak Resonance 1 Frequency (See Spectral Peak control below)
2F	Spectral Peak Frequency	Spectral Peak Resonance 2 Frequency (See Spectral Peak control below)
3F	Spectral Peak Frequency	Spectral Peak Resonance 3 Frequency (See Spectral Peak control below)
1B	Spectral Peak Bandwidth	Spectral Peak Resonance 1 Bandwidth (See Spectral Peak control below)
2B	Spectral Peak Bandwidth	Spectral Peak Resonance 2 Bandwidth (See Spectral Peak control below)

<b>Multipurpose Banks: SineBank</b>			
This table defines SineBank operations as programmed in the matrix. See SineBank Properties for the Fixed settings.			
	3B	Spectral Peak Bandwidth	Spectral Peak Resonance 3 Bandwidth (See Spectral Peak control below)
	1A	Spectral Peak Amplitude	Spectral Peak Resonance 1 Amplitude (See Spectral Peak control below)
	2A	Spectral Peak Amplitude	Spectral Peak Resonance 2 Amplitude (See Spectral Peak control below)
	3A	Spectral Peak Amplitude	Spectral Peak Resonance 3 Amplitude (See Spectral Peak control below)
2			A second bank like SineBank 1, available in Bank B.

**SineBank Properties:**

The SineBank uses a Properties Panel similar to that used by the BiqBank. Select the red “Properties” text under the SineBank label to display the Properties panel in the Control Panel area. The Properties selections work in conjunction with the SineBank column settings. The Properties are unique for each of the two possible SineBanks.

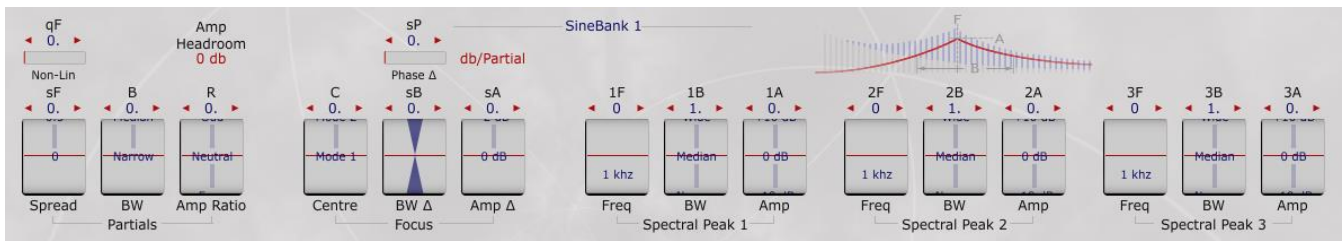

The SineBank Properties controls are divided into three sets of controls that act on the SineBank: Partials, (Centre) Focus and Spectral Peaks as follows:

**Partials Control:**

- **Spread (sF)** (Range: 0.0 .. 2.0, Default: 0.0) – This Property determines the linear frequency spread of the sine partials. A value of 1 sets normal harmonic spacing. A value less than 1 compresses the harmonic spacing. A value greater than 1 expands the harmonic spacing. It is added to the sF column in the matrix if defined.

A non-Linear control above the Spread property can be applied but is intended to be used in conjunction with the non-linear frequency spread column if defined in the matrix. The effect of the non-linear controls is scaled by partial number squared.

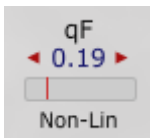

- **BW (B)** (Range: 0.0 .. 2.0, Default: 0.0/Narrow) – This property determines the partial bandwidth. A value of 1 assumes pure sine waves with no noise modulation applied. Values greater than 1 increase the bandwidth of a noise component around each partial's frequency used to amplitude modulate the partial. The Bandwidth Property adds to B column if present in the matrix.
- **Amp Ratio (R)** (Range -1.0 .. 1.0, Default: 0.0/Neutral) – This Property determines the Even/Odd partial amplitude control. It defaults zero/Neutral (normal harmonic amplitudes). A value less than zero suppresses amplitudes of the odd-number partials (emphasizes even partials). A value greater than zero suppresses amplitudes of even-number modes (emphasizes odd partials). This value will be added to the E column if it is defined in the matrix.

**Centre of Focus Control:**

- **Centre (C)** (Range: 0.0 .. 1.0, Default: 0.0/Mode1) – This Property determines the Center-of-Focus of the sine partials. A value of zero means the first partial is centre (most common). A value of 1 means the eighth mode is the center. The Centre control can only be set to a maximum partial of 8. If more partials are defined, the center must be adjusted past eight through additional offsets in the matrix (though in most cases that is not common). A value of 1.5 means the 12 partial is the center. A value of 4 means the 32<sup>th</sup> partial (maximum) is the center, etc. This value will be added to the C column if set in the matrix.
- **BW Δ (sB)** (Range 0.0 .. 1.0, Default: 0.0) – This Property determines the Partial Bandwidth Spread factor. A value of zero means each partial has the same amplitude modulation by noise. A value greater than zero means partials farther from the Centre-of-Focus have increased noise modulation. A value less than zero means partials farther from the Centre-of-Focus has decreased noise modulation. It is added to whatever is defined in the sB (linear) column. If a negative value is desired it must be offset in the matrix as the **BW Δ** control's range has a zero minimum. This value will be added to the sB column if set in the matrix.

A partials phase spread control above the **BW Δ** property will be applied to the sP column if set in the matrix.

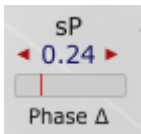

- **Amp. Δ (sA)** (Range 0.0 .. 5.0 / 0dB .. -12dB, Default: 0.0/0 dB) – This Property determines the Partial Amplitude Spread. A value of zero means the Centre-of-Focus does not affect partial amplitudes. A value greater than zero means reduced amplitude of partials farther from the Centre. Partial amplitudes are proportional to dB/Octave or dB/Partial, selectable with the toggle text control above the **Amp. Δ** setting.



The sA column will be added to this value if it is defined in the matrix.

**Spectral Peak Control:**

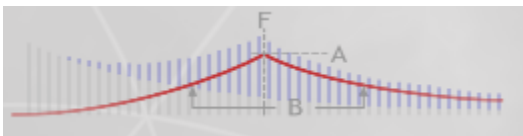

The spectral peaks are three configurable resonances, like formants of your mouth defined by a Frequency, Bandwidth and Amplitude. A partial near the spectral peak can have a lot of amplitude added in, and a partial far from the spectral peak has less amplitude added in. This is indicated by the picture of a “generic” sound above the spectral peak controls; that “generic” sound has partials equally spaced in frequency and a Focus set at the fundamental (so it has decaying amplitudes of partials); the spectral peak adds into those amplitudes.



Note: If using spectral peaks you must set the Amp Headroom control to 24 dB.

- **Spectral Peak 1: Freq (1F)** (Range: 1kHz or 8.7Hz .. 12543.9 Hz / C#0 .. G10, Default: 0.0/1kHz) – This property determines the centre frequency of the first of three possible Spectral Peaks that can be defined. This value will be multiplied by the 1F column in the matrix if it is defined. The Spectral Peak will have greatest influence on amplitudes of partials nearest this frequency. If the default 1 kHz selection in SineBank Properties is not changed, the resulting value computed by multiplying by the 1F matrix column will be in kHz, otherwise the resulting value will be the control value set times the 1F matrix column if present. If no 1F column is present or the formula in that column equals zero and the default 1kH value is set, no spectral peak will be defined.
- **Spectral Peak 1: BW (1B)** (Range: 0.0 .. 2.0, Default: 1.0/Median) – This property determines the bandwidth of the first Spectral Peak. This value is added to the 1B column if defined in the matrix. A value of 1 means the Spectral Peak's contributions to partial amplitudes decrease 6 dB/octave from the centre frequency of the Spectral Peak. A value of 2 means 3 dB/octave, 0.5 means 12 dB/octave, etc. No peak will be created if this value is not changed from its default zero value and no 1B column is defined in the matrix. Also this parameter has no effect if the frequency of the peak is set to zero.
- **Spectral Peak 1: Amp (1A)** (Range 0.0 .. 5.0, Default: 0.0) – This property determines the amplitude of the first Spectral Peak. A value of zero means the spectral peak makes no contribution to partial amplitudes. Larger values correspond to larger contribution to partial amplitudes (as long as the other two properties are set to create a Spectral Peak. This value will be added to the value in the 1A column if it is defined in the matrix.
- Spectral Peak 2: Freq (2F) - Second Spectral Peak that operates identically to Peak 1 Freq.
- Spectral Peak 2: BW (2B) - Second Spectral Peak that operates identically to Peak 1 BW
- Spectral Peak 2: Amp (2A) - Second Spectral Peak that operates identically to Peak 1Amp.
- Spectral Peak 3: Freq (3F) - Third Spectral Peak that operates identically to Peak 1 Freq
- Spectral Peak 3: BW (3B) - Third Spectral Peak that operates identically to Peak 1 BW
- Spectral Peak 3: Amp (3A) - Third Spectral Peak that operates identically to Peak 1Amp.

### Amp Headroom Toggle

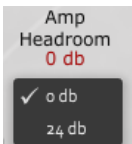

This is useful if you want the centre of focus to have less effect compared to the Spectral Peaks. Sometimes the focus effects on bandwidths of partials will overwhelm the Spectral Peaks.

*Note: You must set the Amp Headroom control to 24 dB if you are using Spectral Peak Controls and/or associated matrix programming.*

### Notes for SineBank:

Unlike other oscillators in the EaganMatrix, SineBank oscillators use simple table lookup for sine values. As a result, the SineBank may have audible table lookup noise at very low frequencies. Use phase modulation or some other technique to mask such noise or use a different method to generate sinusoids (e.g. SineBank with narrow bandwidths).

### Examples of SineBank usage in EaganMatrix System Presets:

*SinebankFM String:* Uses two SineBanks to frequency modulate Oscillators.

*Sinebank Horn*: A simulation of a brass-like texture.

*SinePhases*: Creates texture changes using SineBank phase manipulation.

## 6.7. Multipurpose Banks: SineSpray (Sine Grains)

Multipurpose Banks: SineSpray			
SineSpray 1	A	Amplitude	Amplitude of SineSpray. If a new grain is triggered, this determines its amplitude. If the amplitude is 0, no grains are generated (conserves DSP processing).
	F	Frequency	Frequency of SineSpray's fundamental, in kHz. This is the frequency at which new grains are triggered. It is common to add randomness to this value to create audible clusters within the SineSpray.
	H	Harmonic Truncation	Harmonic truncation, in kHz. Small H creates long sine grains within the spray. Larger H shortens grains and adds harmonics. As H increases, high harmonics increase, and low harmonics are truncated. Try half the S column value.
	P	Phase	If a new grain is triggered, this will be the phase offset for the sinusoid within the grain. Values: 0..0.9999 (0 to 359.9) degrees).
	S	Sine Frequency	If a new grain is triggered, this will be the frequency (in kHz) of the sinusoid within the grain.
2			A second SineSpray like SineSpray 1, available in Bank B or in Bank C.

Note: Typically the frequency of the resulting sound is the frequency of Sine Spray's fundamental (sine grain triggering frequency), not the frequency of the sinusoid within the grain.

### Examples of SineSpray usage in EaganMatrix System Presets:

*Bird Echoer and Bird Whistler*: Creates a looped harmonic shift using a SineSpray, reminiscent of a bird call.

*Harmonic Break*: Controls harmonic timbre shifts with front-to-back finger movement.

*Sonogram*: Creates a diffuse-to-focused noise texture, using noise modulation of a SineSpray.

*SpaceJaw*: A thin band-passed texture, using two SineSprays to create the stereo texture.

*Three Cycles*: Subtle modulations in the SineSpray create a cyclical spinning texture.

## 6.8. Multipurpose Banks: WaveBank (Waveform Cluster)

Multipurpose Banks: WaveBank (Sawtooth, Square, Triangle)			
WaveBank	A	Amplitude	Amplitude of the WaveBank waveform cluster. If the amplitude is 0, no waves are generated (conserves DSP processing).

Multipurpose Banks: WaveBank (Sawtooth, Square, Triangle)			
<b>1</b>  WaveBank 1 Saw ✓ Saw Square Triangle Le Caine	F1	Frequency	Frequency (in kHz) for the first wave generator in the wave cluster.
	F2 - F5	Frequency	Frequency of second through fifth wave generator in the wave cluster. If a column is left blank, fewer waves will be generated by the WaveBank.
	D	Duty	Duty cycle for waves generated by the WaveBank. Values range from 0 to 1 (or equivalently, 0 to -1). Value 0 is normal; if the WaveBank has Square selected, 0 is a 50% duty cycle square, and nonzero is a pulse wave.
	W	Weighting	Weighting of the amplitudes of the waves generated by the WaveBank. 0 is equal weighting. Values higher than 0 up to 1 favor even-numbered waves, and values lower than 0 to -1 favor odd-numbered waves.
	oD	Duty Offset	Offset for the D column's Duty Cycle value. The offset is added once to the second wave in the WaveBank, twice to the third, etc.
<b>2</b>			A second WaveBank like WaveBank 1, available in Bank B or C.

**Notes for WaveBank:**

The WaveBank popup menu provides four choices: Sawtooth, Square, Triangle or LeCaine (see below) waveform aggregates.

The delay memory of VoiceDelay, SummedDelay, MicroDelay, and FormulaDelay is used by the WaveBank, HarMan, and ModMan.

**Note:** When you use a WaveBank, it occupies half the memory of the VoiceDelay, SummedDelay, MicroDelay, and FormulaDelay. If you have one WaveBank (in Bank A or Bank B), you can also have a VoiceDelay, SummedDelay, MicroDelay, and FormulaDelay in Bank C (which will operate using half its normal memory). If you have two WaveBanks (both Bank A and Bank B) as well as a Delay in Bank C, both WaveBanks must specify the same kind of wave (Sawtooth, Square, or Triangle wave). In this last case, if you set them to two different wave forms, the waveform in bank B will be used for both, even if bank B's formulas are disabled.

**Examples of (non LeCaine) WaveBank usage in EaganMatrix System Presets:**

*Boson Particles:* Uses a WaveBank to generate triangle waves. The WaveBank's W column value changes with finger Y position.

*Organzilla:* Creates a Supersaw synth with a Wavebank of Saw waves.

*Squaresville:* Detuned WaveBank of Square waves with delay synthesizer.

### 6.8.1 LeCaine WaveBank

The Le Caine oscillator is emulating the designs of synth pioneer Hugh Le Caine (1914-1977). In his oscillator he had frequency multiples of 1, 2, 3, 4, 5, 8. We also added the duty cycle which was not part of his original design. The Le Caine was based on a high frequency tube circuit, which then divided down frequencies via flip-flop (which is why the wave is square only). Note: Tubes are more stable at higher frequencies, so when you divide down to get to the "fundamental" it's relatively pitch stable.

Multipurpose Banks: WaveBank (LeCaine)			
WaveBank 1	A1	Amplitude	Amplitude of Square wave at the fundamental frequency
	A2	Amplitude	Amplitude of square wave at 2x fundamental frequency.
	A3	Amplitude	Amplitude of square wave at 3x fundamental frequency.
	A4	Amplitude	Amplitude of square wave at 4x fundamental frequency.
WaveBank 1 Le Caine	A5	Amplitude	Amplitude of square wave at 5x fundamental frequency.
Saw	A8	Amplitude	Amplitude of square wave at 8x fundamental frequency.
Square	A4	Duty	Duty cycle for LeCaine square waves generated by the WaveBank. Values range from 0 to 1 (or equivalently, 0 to -1). Value 0 is normal; 0 is a 50% duty cycle square, and nonzero is a pulse wave.
Triangle			
✓ Le Caine			
	F	F	The Fundamental frequency of the LeCaine square wave.
2			A second WaveBank like WaveBank 1, available in Bank B or C.

The LeCaine Wavebank option is an additive Square wave function based on the work of Hugh LeCaine.

#### Examples of LeCaine WaveBank usage in EaganMatrix System Presets:

*Basic LeCaine:* Uses a LeCaine WaveBank with ratioed offsets on the Square Wave amplitudes controlled by a Macro Controller plus a second LeCaine Wavebank using fixed amplitude offsets that can be brought in by another Macro Controller.

## 6.9. Multipurpose Banks: HarMan (Granular Harmonic Manipulator)

Multipurpose Banks: HarMan			
HarMan 1	A	Amplitude	Amplitude of the HarMan. If a new grain is triggered, this determines its amplitude. If the amplitude is 0, no grains are generated (conserves DSP processing).
	F	Frequency	Frequency of HarMan's fundamental, in kHz. This is the frequency at which new grains are triggered.
	H	Harmonic Truncation	Harmonic truncation, in kHz. If a new grain is triggered, the grain's duration will be inversely proportional to this value. As H increases, low harmonics are truncated, and high harmonics intensify. Try .16 times the S column value.
	I	Index	Index into data selected in the Spectral Set popup menu. Value 0 to 1. For "Live (From Delay)" selected in the Spectral Set popup menu: If I is from 0 to 1, I is relative to the write-index point of the circular delay buffer. -1 aligns to most recent grain positions with 2*H, and -2 aligns to most recent grains only when S>1.
	S	Spectral Dilatation	Spectral Dilatation. 1 means no change to spectral envelope (i.e. step through grain data normally), >1 stretches spectral envelope (i.e. increased step rate through grain data), <1 compresses spectral envelope (i.e. decreased step rate through grain data). Usually scale the H column value by the same amount.
2			A second Harmonic Manipulator like HarMan 1, available in Bank B or C.

### Notes for HarMan:

HarMan uses precision granular techniques to traverse and manipulate a very short (150ms) sample. A pre-loaded set of samples is provided within the "Spectral Sets" menu. *Currently, it is not possible to load your own 150ms spectral sets.* Do not think of HarMan like a sampler or like a traditional granular technique; instead, it is a way to traverse and manipulate the spectral evolution of a very-short-but-interesting sample. The sample is so short that it only provides 12 different "raw" grains; each grain has its own unique spectrum. By cleverly manipulating this tiny amount of data, amazing results are possible: the VlnVlaCelBass presets manipulate a single 150ms sample (the very beginning of a single viola note) to make a beautiful full-range string synthesis). Unlike sampling, where the sound is automated by the synthesizer, here the granular synthesis is influenced in tiny detail by the performer's finger motions. Be aware that the intricacies of a well-designed HarMan preset is tied to the particular Spectral Set it uses; it won't be possible to get the same results with a different Spectral Set. Also be aware that you will not hear the traditional sonic effects of randomized grains with HarMan; the grain start times and grain interpolation is refined to sub-sample accuracy to avoid such effects, and the SineSpray is better-suited for that sonic purpose.

The available Spectral Set options are:

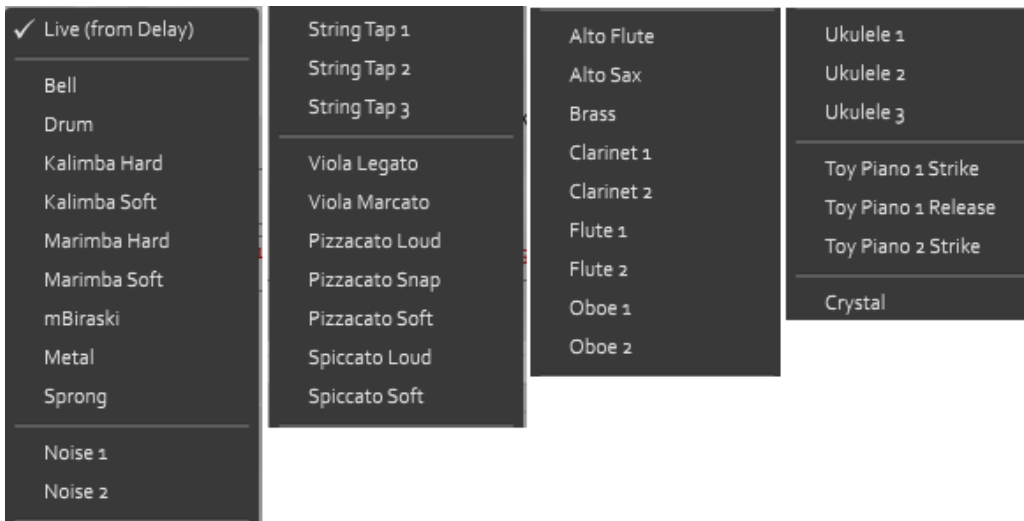

**Live From Delay Option:**

In addition to the tiny samples in the Spectral Sets menu, the HarMan can granulate live input (recorded into the Delay buffer), but so far this possibility has been explored primarily by Continuum player and sound designer Benedict Slotte. However, it is now a more accessible option on the EaganMatrix module that accepts direct analog audio input so an AES conversion is not required as on the Continuum (this is not supported on the ContinuuMini). This function for example can easily allow you to perform granular pitch shifting on an audio input.

Consider the following simple example. The Left Audio input channel is sent into a Voice Delay using a small delay (50ms). The Harman1 is set to “Live (From Delay)” and parameters are set to perform granular shifting. The output of Harman (Bank A) is sent to SL/SR. Each of the Harman parameters (except fixed unity amplitude input) is associated with a Macro Controller to allow its value to be changed during performance.

When using Live From Delay, remember to bring up the Audio Input Level Control of the Live From Delay function will have no effect.

**Using Harman Live (from Delay) Option**

**Make sure  
Audio  
Input is  
turned up**

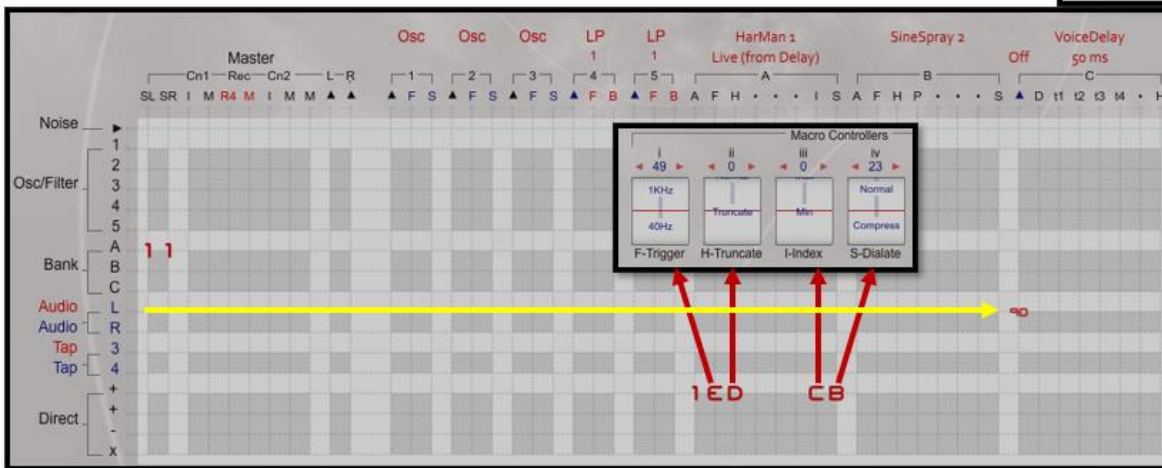
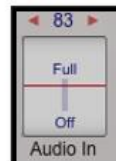

The delay memory of VoiceDelay, SummedDelay, MicroDelay, and FormulaDelay is used by the WaveBank, HarMan, and ModMan. For HarMan, a popup menu allows you to select a predefined **Spectral Set** to load into the Delay memory, or **Live** to manipulate time-domain data (312.5 Hz fundamental) you record into the SummedDelay.

**Note:** When you select a Spectral Set, it occupies half the memory of the VoiceDelay, SummedDelay, MicroDelay, and FormulaDelay. If you have one Manipulator with Spectral Set (in Bank A or Bank B), you can also have a VoiceDelay, SummedDelay, MicroDelay, and FormulaDelay in Bank C (which will operate using half its normal memory). If you have two Manipulators (both Bank A and Bank B) as well as a Delay in Bank C, both Manipulators must specify the same Spectral Set.

**Examples of HarMan usage in EaganMatrix System Presets:**

*Bell Rub:* Uses finger pressure to control a cyclical traversal of bell spectra.

*Cycle Kalimba:* A moving kalimba-like sound.

*GrainSilo Woodwind:* A generic woodwind-like timbre with a wide pitch range.

*SiloString Pizz:* Transforms spectra from a viola pizzicato into a guitar string.

*Spinning Duet:* Creates a stereo spinning texture by cycling through spectra from a flute.

*VlaVlaCelBass:* A full-range solo orchestral string sound, created by manipulating spectra from a single viola tone.

**6.10. Multipurpose Banks: ModMan (Modal Manipulator)**

Multipurpose Banks: ModMan			
ModMan 1	▲	Audio Input	Excitation input for all modes of the ModMan.
	F	Frequency	Frequency (in kHz) for the first mode in the ModMan.
	sF qF sA	Frequency Spread Quadratic Frequency Amplitude Spread	Select this column's function by clicking on the column's heading. sF=1 for harmonic spacing of modes, >1 stretched spacing, <1 compressed. qF times mode-number-squared is each mode's frequency offset. sA>0 reduces amplitude of modes farther from Centre (see below).
	B	Bandwidth	Mode bandwidth control, smaller values increase resonance.
	sB qB	Bandwidth Spread Quadratic Bandwidth	Select this column's function by clicking on the column's heading. sB>0 increase bandwidth farther from Centre (see below), <0 decrease. qB times distance-from-Center-squared is bandwidth offset.
	C	Centre	0 means first mode is Centre, 1 means the 8th mode is Centre.
	I	Interpolation Index	Interpolation between spectra selected in the Spectral Set popup menu. The interpolated spectrum determines the amplitude of each mode. Value 0 to 1; 0 is first spectrum in the Set, 1 is the last spectrum.

Multipurpose Banks: ModMan			
	S	Spectral Dilation	1 for unchanged spectral envelope, >1 stretched spectrum, <1 compressed. Normally the S and H columns differ only by a scale factor.
2			A second filter bank like ModMan 1, available in Bank B.

**Notes for ModMan:**

The ModMan uses modal techniques (bandpass resonances) to manipulate information derived from a very short (150ms) sample. A pre-loaded set of samples is provided within the “Spectral Sets” menu. *Currently, it is not possible to load your own 150ms samples.* When ModMan is loaded, it performs a short-time Fourier transform of the selected 150ms sample and uses the results to manipulate mode amplitudes under EaganMatrix control.

In addition to the transform of data in the Spectral Sets menu, ModMan can directly use frequency-domain data recorded in the delay buffer (see below), but so far this possibility has not been explored by anyone.

The delay memory of VoiceDelay, SummedDelay, MicroDelay, and FormulaDelay is used by the WaveBank, HarMan, and ModMan. For ModMan, a popup menu allows you to select a predefined **Spectral Set** to load into the Delay memory, or **Live** to manipulate spectral envelope data (period 620.69 Hz, the data within each period are the spectral amplitudes) you record into the SummedDelay.

The Deflation Limit (above the last ModMan matrix column) avoids excessive buildup of energy inside the ModMan but has no effect under normal playing conditions. Set the Deflation Limit to the largest value (between 0 and 7) that does not affect the timbre of the sound. Click on the Deflation Limit to change its value.

**Note:** When you select a Spectral Set, it occupies half the memory of the VoiceDelay, SummedDelay, MicroDelay, and FormulaDelay. If you have one Manipulator with Spectral Set (in Bank A or Bank B), you can also have a VoiceDelay, SummedDelay, MicroDelay, and FormulaDelay in Bank C (which will operate using half its normal memory). If you have two Manipulators (both Bank A and Bank B) as well as a Delay in Bank C, both Manipulators must specify the same Spectral Set.

**Examples of ModMan usage in EaganMatrix System Presets:**

*Harp:* Uses the VIn Pizz Soft spectra to create a sustained harp-like sound.

*Koto:* Uses the VIn Pizz Snap spectra to create a sustained koto-like sound.



## 6.11. Multipurpose Banks: Additive (Additive Synthesis)

Multipurpose Banks: Additive Synth			
Additive Synth 1	▲	Modulation Input	Modulation input for Additive Synthesis. Modulates sine wave components that are below the N column threshold, thereby creating bandwidth for low-amplitude components. The amplitude and frequency content of this input determines the bandwidth effect (normally LPF filtered noise). To disable all modulation (pure additive sine-wave synthesis) leave this column and the B column blank (or 0).
	F	Frequency	Frequency (in kHz) of the fundamental sine wave component of the Additive Synthesis.
	sF qF	Frequency Spread Quadratic Frequency	Select this column's function by clicking on the column's heading. -1 to 1: 0 normal spacing of sine wave components, >0 stretched, <0 compressed. -1 to 1: 0 normal spacing, ≠0 quadratically offset by component number.
	N	Bandwidth	Noise (Bandwidth) modulation threshold. When a sine wave component's amplitude envelope drops below this threshold, it will be amplitude modulated by Additive's first column. 0 prevents modulation, 1 modulates all components, <0 reverses the sense of the threshold (only components with amplitude envelope above the negative threshold are modulated). Note: Used to be "B" in 9.55.
	sA dF pA I'	Amplitude Spread Deviation Frequency Prune Amplitude Interpolation Index	Select this column's function by clicking on the column's heading. sA: >0 reduces amplitude farther from Centre (see below), <0 decreases. dF: Deviation from reference frequency (1=Normal). Used to be qA) pA controls number of sines to play, starting at sine specified by C column. I and I' data are interpolated under control of C column: C = 0 (I) to C = 1 (I').
	C	Centre	Additive Synthesis's Centre control. Value 0 to 1: 0.00 means first sine wave component is centre, 0.01 means 2nd sine wave is centre, 0.95 means last (96th) sine wave component is centre.  Special meaning if I' column is in use: interpolation control, C = 0 (I) to C = 1 (I').
	I	Analysis Data Index	Index into Additive Analysis Data. Value 0 to 1 is Mahling phrase; 1.0 to 1.1 is first user analysis slot, 1.1 to 1.2 is second, up to 1.9 to 2.0 for tenth user analysis. Hint: Use a constant in the Direct+ row to select an analysis, then add a formula with shape generator to traverse the analysis.
	S	Spectral Dilation	0 means no change to spectral envelope, >0 stretches spectrum, <0 compresses.
2			A second Additive Synth like Additive Synth 1, available in Bank B.

### Notes for Additive Synth:

Additive Synth has 96 sine wave oscillators. The amplitude and frequency of each sine wave component is continually updated based on Additive Analysis data read from flash memory. The EaganMatrix can index to any point in the Analysis data, allowing for time stretch, time compression, randomly indexing the Analysis Data, or running through the Analysis Data backwards. The EaganMatrix can shift frequencies and amplitudes of the Analysis Data, interpolate between two different indices into the Analysis, and play a subset of the sine wave components. The Additive Synth is

limited in several ways: it has limited Analysis Data Memory, the Analysis Data must be prepared ahead of time, and it provides only a few options for manipulating the data. Still, the Additive Synth can be used in creative and unexpected ways. For example, it is possible to make percussion-like sounds by artfully traversing certain parts of the Mahling phrase (a bit like beatboxing) or make creepy voices by playing very low notes while silencing (pruning out) the first 20 sine wave components.

When Additive banks are in use, maximum polyphony is limited due to the inherent high memory requirements. C1x and L1x systems will have max polyphony 2, M2x and L2x max polyphony 4, L6x max polyphony 12.

One 19.2 second Additive Analysis is preloaded on all Continuums (the “Mahling phrase”). In addition, on L2x, M2x, and L6x systems: Ten User Analysis slots are available, for customized additive analyses. Each User Analysis slot is 1.92 seconds long; adjacent slots may be combined if longer analyses are required. The Continuum Editor’s Additive Analysis tool can create User Analyses, if you supply a sample for Midi note number 55 (G3, or 196 Hz). Skill and patience are required to record and prepare samples that result in good-sounding analyses, and more skill and patience to create EaganMatrix presets that manipulate the analyses in an interesting way. The one-time download for a User Analysis slot takes about 2 minutes. *The Continuum Editor’s Analysis Tool is not yet available at time of this writing.*

**Examples of Additive Synth usage in EaganMatrix System Presets:**

*Vocal: Additive Vocal 1 Transform, Additive 1, Instant Reich, Shall I Stay or Shall I Go*

**6.12. Multipurpose Banks: Kinetic (Kinetic Physical Model)**

Multipurpose Banks: Kinetic Model			
Kinetic Model 1	▲	Excitation Input	This is a force on the Kinetic Model's mass, value range -2 to 2. The output of the Kinetic Model will be the position of the mass.
	B	Bow Speed	Value range -1 to 1. In the Kinetic Model's Properties, Slipping Friction and Quit-slipping Speed will affect the function of the bow.
	μ	Static Friction	Static Friction (Stiction) value range 0 to 1.
	F	Frequency	Frequency, in kHz. In the Kinetic Model's Properties, the Step Frequency Trim adjusts the model to make this column exact kHz units.
	A K M G V P S Q	Anchor Position Spring Constant Mass Gravity Viscosity Padding Slipping Friction Quit-slipping Friction	In the Kinetic Model’s Properties, values may be set for model parameters. Kinetic Model’s matrix columns allow changes to properties during a note.  Select the function of the last four Kinetic columns by clicking on each column’s heading. The value computed in the column will be added to the corresponding value in the Kinetic Model’s Properties.
2			A second Kinetic Model like Kinetic Model 1, available in Bank B.

**Notes for Kinetic Model:**

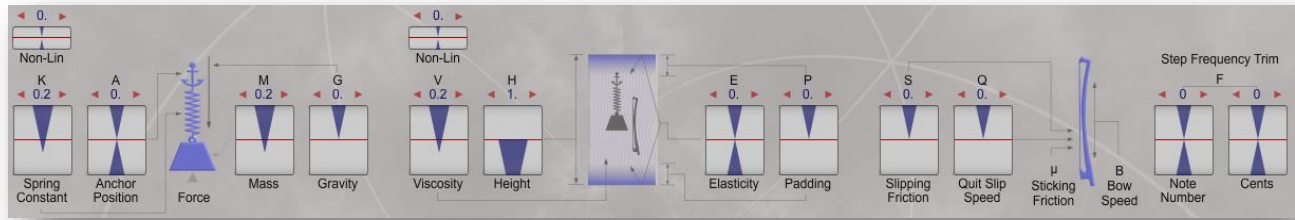

The Kinetic Model is a state-space model of a mass attached to a spring which is anchored within a 1-dimensional container of viscous fluid. The output of the model is the position of the mass.

The mass may be set in motion by the Excitation Input (“external impact”), which exerts a positive or negative force on the mass. The mass may also be set in motion by bowing the mass, or by moving the anchor point of the spring attached to the mass, or by changing the height of the container so that its edge hits the mass, or by changing gravity, or other ways. The mass may oscillate due to the spring, or it may bounce between the top and bottom edges of the container, or it may bounce along the bottom edge of the container. The “padding” parameter can be used to emulate deformation of the container when the mass bounces. Viscosity slows any motion of the mass.

**Kinetic Model Properties**

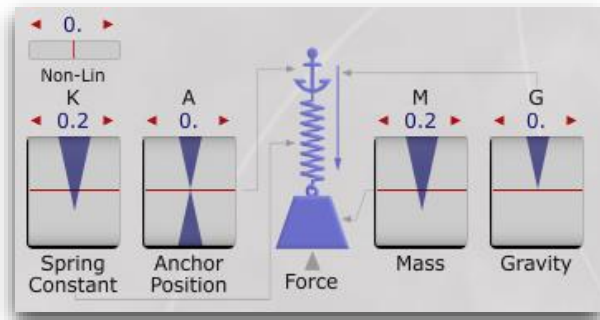

**Anchor Position (A)** affects the “resting position” of the mass. A nonzero offset is sonically interesting since it breaks the overall symmetry of the model. Setting the Anchor Position with an audio signal is a useful way to excite the model.

**Mass (M)** of the mobile body connected to the spring. The higher the mass is, the more difficult it is to start moving, but the longer it will move, due to inertia. High mass also usually results in bass sound.

**Spring constant (K)** is the strength of the spring, the higher this strength is, the higher frequency you will get. The strength can be zero, in which case the spring and the anchor position have no effect.

**Spring Linearity** is 0 for an ideal spring ( $F=kx$ , with  $k$  fixed, whatever the distance  $x$  from anchor position is). If it is positive, the spring force will be lower when distance from the anchor position is small. If it is negative, the spring force will be lower when distance from the anchor position is high. This property is not modifiable from formulas in the matrix.

**Gravity (G)** is acceleration and is not dependent on the mass. Gravity is sonically interesting because it breaks the overall symmetry of the model, but ultra-high gravity will result in silence because the mass will stay on the bottom edge of the container (defined by the Height property).

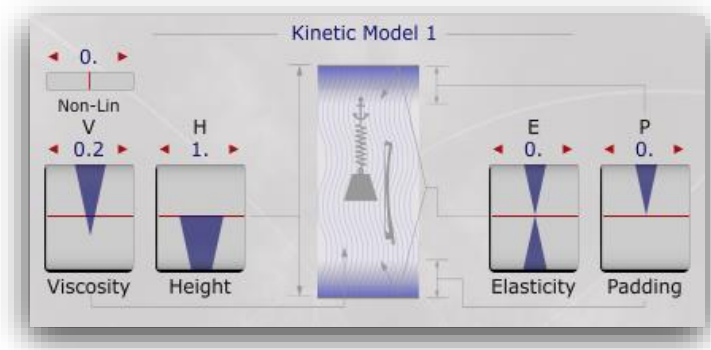

**Height (H)** determines the size of the container. If there is no bouncing (see Elasticity), the mass will be quickly stop when it reaches the top or bottom edge of the container; it will be stopped and lose all its kinetic energy, so the effect is quite different from “normal” audio signal clipping.

**Viscosity (V)** is friction due to fluid filling the container. Viscosity slows the motion of the mass. A Viscosity of 0 is like vacuum, a viscosity of 1 is like heavy oil.

**Viscosity Linearity** is 0 for ideal linear viscosity. If it is positive, the friction will be lower when the speed is small. If it is negative, the friction will be lower when the speed is high. This property is not modifiable from formulas in the matrix.

**Elasticity (E)** determines if the mass bounces or sticks when it hits the edges of the container. When set to 0, the mass loses all its energy when hitting the edges. When set to maximum positive value, the mass bounces and keeps all its energy when hitting the edges. Intermediate values set the percentage of energy kept when bouncing. Negative values define a sticking force, so additional force on the mass will be required to escape from the edge (it is as if the mass is glued to the edge); if the mass stays stuck to the edge, silence results.

**Padding (P)** is a property of the container, which may be hard (like metal) or soft (like foam). For a soft container, a deformation occurs when the mass hits the edges, resulting in a smoother deceleration. To simulate this, Padding defines a deceleration area near the edges.

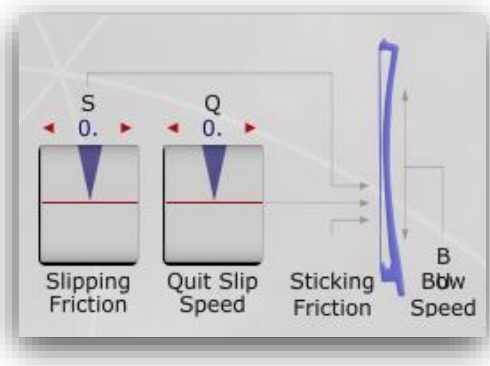

**Static Friction ( $\mu$ )** (or stiction) must be set from the matrix. This determines the minimum force that must be applied before the mass starts moving. Note that for high values of stiction, silence results because the mass is not able to move. Also note that for higher mass, a greater force will be needed to put the mass in motion.

**Slipping Friction (S)** is the friction experienced by the mass once it is in motion (once it has overcome stiction). This friction does not depend on the speed of the mass, unlike friction due to viscosity. 0 means no slipping friction, and 1 (maximum) means that the slipping friction is the same value as the static friction.

**Quit-slipping Speed (Q)** is the minimum speed that the mass will move before it stops and static friction takes over.

**Bow Speed (B)** must be set from the matrix. It is the speed of the contact surface from which the static friction results. The sign of the speed defines the direction of the motion. A value of 0 means no bowing. This parameter has no effect if Static Friction is zero.

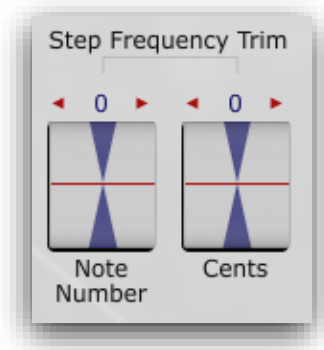

**Step Frequency Trim (F)** controls the pitch of the Kinetic Model's output; it changes how much model time passes in each sample interval. The Step Frequency Trim parameters (Note Number and Cents) should be set such that Kinetic Model's F matrix column is in kHz; these trim settings are unique to each model.

**Examples of Kinetic Model usage in EaganMatrix System Presets:**

*Drones: Bad Weather, Earthquake, Kinetic Evil Ball*

*Synth: Kinetic SatPad*

*Utilities: See the Various Kinetic Examples*

### 6.13. Multipurpose Banks: CVC Control Voltages (Continuum Voltage Converter)

Multipurpose Banks: CVC		
<b>W</b>	1	CVC control voltage output 1.
<b>X</b>	2	CVC control voltage output 2.
<b>Y</b>	3	CVC control voltage output 3.
<b>Z</b>	4	CVC control voltage output 4.
<b>W</b>	5	CVC control voltage output 5.
<b>X</b>	6	CVC control voltage output 6.
<b>Y</b>	7	CVC control voltage output 7.
<b>Z</b>	8	CVC control voltage output 8.

The EaganMatrix-to-CVC assignments map as follows to the first eight CVC outputs if programmed in the Matrix. A set of CVC programming examples are available in the Utilities/CVC Category that can be used as starting points for additional changes if desired.

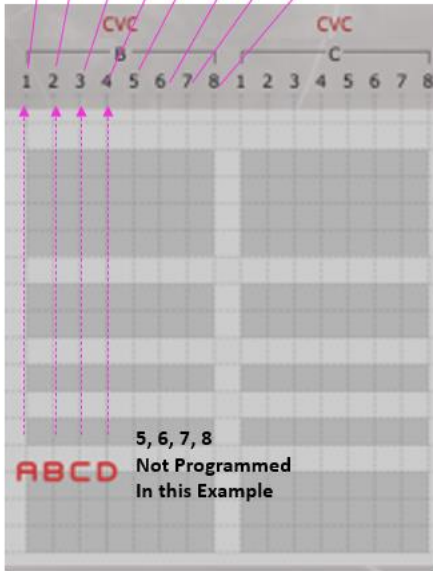

- A = W (Gate) Formula
- B = X (Pitch) Formula
- C = Y (Bottom/Top) Formula
- D = Z (Pressure) Formula

(These can be any available EaganMatrix formulas)

Typically each of the formulas applied to one of the CVC columns will map to its related CVC fingerboard mapping: W, X, Y or Z. Here is one possibility of the formulas for the above example:

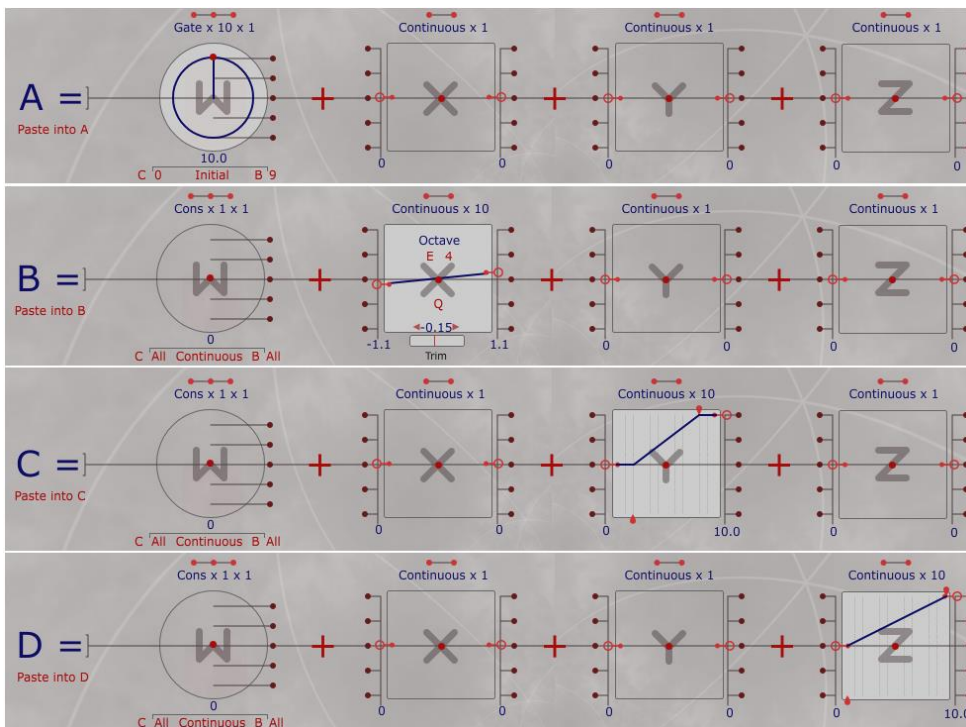

**Formula A:** Here uses a W gate of 10V. You could change this to a lower value.

**Formula B:** Maps X voltage. Note that here it is set to Octave mode which will auto-scale voltage per octave. You could set it to a different voltage formula if you are not interested in standard pitch output. If this is set Octave, Min V = -1.0 and Max V = + 1.0, the voltage will scale 1 Volt per octave (a normal setting for Eurorack and many synths) but you can adjust for other scaling factors. In this case it is scaled -1.1V to + 1.1V with a trim offset of -0.15 cents. This maps better to a Moog synth which is not exactly 1V per octave. If using Buchla that uses a 1.2V per octave mapping, this should be set Min V = -1.2 , Max V = + 1.2, etc.

**Formula C:** Here uses a linear Y CV scaling of 0 to 10V with beginning and ending shelving. This can be set to any of the Y patterns if desired

**Formula D:** Here uses a linear pressure scaling of 0 to 10 V. This can be set to any of the Z patterns if desired.

**Notes for CVC:**

Select CVC in Bank B or in Bank C to create preprocessed Continuum Voltage Converter outputs using the EaganMatrix (they act identically).

If the EaganMatrix is supplying CV voltages, the Editor will display “CVC via Matrix” in the Editor. Otherwise, the Editor will display the Standard CV Definition being used. See the CVC User Guide for details. Values will be interpreted as voltages, though X formula will auto-scale to desired pitches if set to “Octave”. Don’t set more than 10V, though the CVC should limit to 10V if you set higher.

When a CVC bank is in use, the CVC will be controlled by the EaganMatrix, with eight control voltages per note (two voices in one CVC). The columns in the EaganMatrix CVC bank specify voltage values.

A set of predefined CVC presets are available in the CVC System Preset category – which map to the default settings available in the CVC option list when the CVC is not programmed through the EaganMatrix.

Two of the Continuum Fingerboard’s split modes will override the EaganMatrix control of the CVC:

**Internal Sound Below Split** - the EaganMatrix sound will be below the split point and the CVC control will be above the split point using the selected Standard CV Definition.

**Internal Sound Above Split** - the EaganMatrix sound will be above the split point and the CVC control will be below the split point using the selected Standard CV Definition.

Note: Split modes do not apply to the ContinuuMini. The ContinuuMini can connect to both the CVC and the uCVC, but only two channels of WXYZ voltages are available from the CVC. This maps well to the CVC programming described here, however when playing duo-tactically, CVC values can be unpredictable. It is best to play the ContinuuMini monophonically for most predictable CVC output.

Note: Fixed CVC output options are available in Control Panel 3 of the Haken Editor. The last has been added for EaganMatrix support with 1V/Oct on X, 0-5V for Y and 0-5V for Z.

- ✓ 0. C4 10v +Y (G=10v nn60=0v 1vpo Y=0..10v Z=0..10v)
- 1. C4 5v ±Y (G=10v nn60=0v 1vpo Y=-5..5v Z=0..5v)
- 2. C0 5v ±Y (G=5v nn12=0v 1vpo Y=-5..5v Z=0..5v)
- 3. C0 10v ⊕Y (G=10v nn60=0v 1vpo Y=0..10v for Y>.5 Z=0..10v)
- 4. Voyager (G=10v nn52=0v 1vpo Y=-5..5v Z=0..5v)
- 5. Buchla (G=10v nn10=0v 1.2vpo Y=0..10v Z=0..10v)
- 6. C2 5v +Y (G=5v nn36=0v 1vpo Y=0..5v Z=0..5v)
- 7. C4 5v +Y (G=5v nn60=0v 1vpo Y=0..5v Z=0..5v)

## 6.14. Multipurpose Banks: VoiceDelay (Audio Delay Buffer, each voice separate)

Multipurpose Banks: VoiceDelay			
VoiceDelay	▲	Audio Input	Audio input into the VoiceDelay. If the VoiceDelay is operating at reduced sample rate, this input passes through an optional anti-aliasing filter.
	D	Delay Time	Delay time. 0 = no delay, 1 = delay by max amount selected in the Delay menu. The primary output of the VoiceDelay is available on the Bank C row of the EaganMatrix.
	T1	Tap 1	Delay time for Tap 1. This is a multiplier on the D column value. 0 = no delay, 1 = delay by D value. The Tap 1 and 2 outputs are available as an alternative on the AesIn matrix rows.
	T2	Tap 2	Delay time for Tap 2, values 0 to 1. 0 = no delay, 1 = delay by D value.
	T3	Tap 3	Delay time for Tap 3. 0 = no delay, 1 = delay by D value. The Tap 3 and 4 outputs are available as an alternative on the Sub matrix rows.
	T4	Tap 4	Delay time for Tap 4. 0 = no delay, 1 = delay by D value.
	H	Hold	Greater than zero stops recording new data into the VoiceDelay.

### Notes for VoiceDelay:

VoiceDelay, SummedDelay, MicroDelay, and FormulaDelay are four different ways to use the one underlying delay memory. This delay memory is also used by the WaveBank, HarMan, and ModMan.

The **VoiceDelay** provides a multi-tap audio delay buffer, separate for each voice. VoiceDelay is suitable for creating chorus and flanging effects, can be used for fast slap delays. VoiceDelay is available in Bank C.

The Delay popup menu has a choice of maximum delay times for the VoiceDelay.

The sample rate of the VoiceDelay memory is limited by two variables: maximum delay and polyphony. Longer delays or higher polyphony may result in reduced sample rate for the delay memory. The **Anti-Aliasing Low Pass Filter** indicator above the first Bank C column will light up when the delay memory is at reduced sample rate. If you do not want an Anti-Aliasing filter at reduced sample rates, click on the indicator to disable the filter.

**Note:** When a Manipulator with Spectral Set is in use (in Bank A or Bank B), the VoiceDelay will still operate, using half the normal amount of delay memory.

### Examples of VoiceDelay usage in EaganMatrix System Presets:

*Echo 8va:* An echo that combines elements not in the original dry note.

*Echo Star:* Uses an echo to modify the pitch of an Oscillator.

*Follower:* Delays a control-level signal to create a distinct single echo, which follows the pitch of the dry note with an alternate texture.

*Mutate Looper:* Sonically modifies an extended delay by filters and oscillators.

*Ping Pong:* Subtle delay creates stereo depth.

*Razor Loops:* Short delay values create a pitched-noise texture.

*Swept Delay:* Sonically modifies a delay with slow filter sweeps.



*Waterphone Strings*: Uses VoiceDelay tap outputs to create a chorusing effect.

## 6.15. Multipurpose Banks: SummedDelay (Audio Delay Buffer, shared by all voices)

Multipurpose Banks: SummedDelay			
SummedDelay	▲	Audio Input	This voice's audio input contribution to the shared SummedDelay. If the SummedDelay is operating at reduced sample rate, this input passes through an optional anti-aliasing filter.
	D	Delay Time	Delay time. 0 = no delay, 1 = delay by max amount selected in Delay menu. The primary output of the SummedDelay is available on the Bank C row of the EganMatrix.
	T1	Tap 1	Delay time for Tap 1. This is a multiplier on the D value. 0 = no delay, 1 = delay by D value. The Tap 1 and 2 outputs are available as an alternative on the AesIn matrix rows.
	T2	Tap 2	Delay time for Tap 2. 0 = no delay, 1 = delay by D value.
	T3	Tap 3	Delay time for Tap 3. 0 = no delay, 1 = delay by D value. The Tap 3 and 4 outputs are available as an alternative on the Sub matrix rows.
	T4	Tap 4	Delay time for Tap 4. 0 = no delay, 1 = delay by D value.
	H	Hold	Greater than zero stops recording new data into the SummedDelay.

### Notes for SummedDelay:

VoiceDelay, SummedDelay, MicroDelay, and FormulaDelay are four different ways to use the one underlying delay memory. This delay memory is also used by the WaveBank, HarMan, and ModMan.

The **SummedDelay** provides a single multi-tap audio delay buffer shared by all voices. SummedDelay is a summed aggregate of all voices in one shared delay. The SummedDelay is available in Bank C.

The Delay popup menu has a choice of maximum delay times for the SummedDelay.

The sample rate of the SummedDelay memory is limited by the maximum delay selected in the Delay menu. The **Anti-Aliasing Low Pass Filter** indicator above the first Bank C column will light up when the delay memory is at reduced sample rate. If you do not want an Anti-Aliasing filter at reduced sample rates, click on the indicator to disable the filter.

The SummedDelay is often used with the PScaler function as a multiplier (scale factor) on the input. The SummedDelay is not a sum of all available delay modules in a multi DSP system, but instead the sum in each DSP individually, that are then combined together acting as a single unit. When using the PScaler as a multiplier in the input column to the Summed delay, changes to the polyphony will properly compensate for how many voices are being fed into the delay at a time. This is

critical if one is using a feedback system, like when designing repeating echoes. Without the PScaler a change in polyphony would change the levels of feedback input.

**Note:** When a WaveBank or Manipulator with Spectral Set is in use (in Bank A or Bank B), the SummedDelay will still operate, using half the normal amount of delay memory.

**Examples of SummedDelay usage in EaganMatrix System Presets:**

*Left Hand Filter Echo:* Creates echo control for the left hand, while the note is produced with the right hand.

*Voyager:* Creates a pulse delay by modifying the Recirculator output level with a Shape Generator.

*Instant Reich:* See formula D for use of the PScaler function.

**6.16. Multipurpose Banks: MicroDelay (Waveguide Physical Model)**

<b>Multipurpose Banks: MicroDelay (Four Short Audio Delay Buffers for Each Voice)</b>			
MicroDelay	▲	Audio Input 1	Audio input into MicroDelay's first single-tap delay buffer. If the MicroDelay is operating at reduced sample rate, the audio inputs pass through an optional anti-aliasing filter.
	T1	Tap 1	Delay time for MicroDelay's first delay buffer. 0 = no delay, 1 = delay by max value (selected in the Delay menu). The Tap 1 output is available as an alternative on the Sub matrix rows. The sum of Taps 1..4 are available on the Bank C matrix row.
	▲	Audio Inputs 2-4	Three additional audio inputs like Audio Input 1.
	T2-T4	Taps 2-4	One delay time for each audio input 2 through 4. 0 = no delay, 1 = delay by max value. The Tap 2..4 outputs are available as an alternative on the Sub and AesIn matrix rows.

**Notes for MicroDelay:**

VoiceDelay, SummedDelay, MicroDelay, and FormulaDelay are four different ways to use the one underlying delay memory. This delay memory is also used by the WaveBank, HarMan, and ModMan.

The **MicroDelay** provides four single-tap audio delay buffers for each voice. The MicroDelay is available in Bank C. The outputs of MicroDelay's four delay buffers are available on the Tap 1..Tap4 matrix rows (alternative choices for the Sub and AesIn matrix rows). The sum of all four delay buffers outputs (Tap 1 + Tap 2 + Tap 3 + Tap 4) is available on the Bank C matrix row.

The Delay popup menu has a choice of maximum delay times for the MicroDelay.

The sample rate of the delay memory is limited by two variables: maximum delay and polyphony. The **Anti-Aliasing Low Pass Filter** indicator above the first Bank C column will light up when the delay memory is at reduced sample rate. If you do not want an Anti-Aliasing filter at reduced sample rates, click on the indicator to disable the filter.

**Note:** When a WaveBank or Manipulator with Spectral Set is in use (in Bank A or Bank B), the MicroDelay will still operate, using half the normal amount of delay memory.

**Examples of MicroDelay usage in EaganMatrix System Presets:**

*SoundBoard*: Uses four audio delay buffers with relatively prime delay lengths, coupled sequentially.

**6.17. Multipurpose Banks: FormulaDelay (Control Information Delay Buffer)**

<b>Multipurpose Banks: FormulaDelay (Delay Buffers for Control Information, for use in Formulas)</b>			
FormulaDelay	▲	Buffer 1 Input	Input to FormulaDelay's first delay buffer. This buffer's output is available by selecting Buffer 1 in the W component of a formula.
	D1	Delay for Buffer 1	Delay time for FormulaDelay's delay buffer 1. 0 = no delay, 1 = max delay (selected in the Delay menu).
	▲	Buffer 2 Input	Input to FormulaDelay's first delay buffer. This buffer's output is available by selecting Buffer 2 in the W component of a formula.
	D2	Delay for Buffer 2	Delay time for FormulaDelay's delay buffer 2. 0 = no delay, 1 = max delay (selected in the Delay menu).
	▲	Buffer 3 Input	Input to FormulaDelay's third delay buffer. This buffer's output is available by selecting Buffer 3 in the W component of a formula.
	D3	Delay for Buffers 3 & 4	Delay time for FormulaDelay's delay buffers 3 & 4. 0 = no delay, 1 = max delay (selected in the Delay menu).
	▲	Buffer 4 Input	Input to FormulaDelay's third delay buffer. This buffer's output is available by selecting Buffer 4 in the W component of a formula.
	H	Hold for Buffers 1..4	$H \leq 0$ is normal operation. $H > 0$ stops recording new data into buffers. Transition from $H \geq 0$ to $H < 0$ clears all four buffers.

**Notes for FormulaDelay:**

VoiceDelay, SummedDelay, MicroDelay, and FormulaDelay are four different ways to use the one underlying delay memory. This delay memory is also used by the WaveBank, HarMan, and ModMan.

The **FormulaDelay** provides four delay buffers for each voice, for delaying control data used in Matrix formulas. Typical values to feed through a FormulaDelay might be X, Y, Z, or a pedal. The FormulaDelay is available in Bank C. No output from FormulaDelay appears directly on matrix rows; instead, the delay buffer outputs are available by selecting Buffer 1..4 in the W component of formulas.

The Delay popup menu has a choice of maximum delay times for the FormulaDelay.

The sample rate of FormulaDelay's delay memory is normally at the formula evaluation rate (1 kHz), but it can be limited by two variables: maximum delay and polyphony. Very long delays or high polyphony may result in reduced sample rate for the delay memory. Consider filtering or slewing the data inputs to FormulaDelay when using long delay times in the Delay popup menu, to avoid aliasing the control signals being delayed through FormulaDelay.

**Note:** When a WaveBank or Manipulator with Spectral Set is in use (in Bank A or Bank B), the FormulaDelay will still operate, using half the normal amount of delay memory.

**Examples of FormulaDelay usage in EaganMatrix System Presets:**





*Synth Lead 4, The Long Goodbye, Seasons Ch1*

## 6.18. Shape Generators

SGs (Shape Generators)			
1		Frequency	Frequency (in Hz) of the SG. This value should be a sub-audio rate < 30 Hz.
		Phase	For "Phase from Amplitude", this column controls the phase.
		Trigger	Triggers SG when T changes from T≤0 to T>0. Stops SG when T<0.
		Frequency	For "Dual", this controls the frequency (in Hz) of the secondary SG.
2 - 5			Four more SGs like SG 1.

**Notes for Shape Generators:**

Shape Generators are intended for use at sub-audio rates. Highest quality results are obtained with frequencies less than 30 Hz. They can be used to create Low Frequency Oscillation (LFO) components to presets and other repetitive functions based on the SG shape selected.

At the top of each SG column, you may choose Continuous Cycle , Single Cycle , Phase from Amplitude  or Dual (W trigger/Single Cycle) .

Single Cycle and Continuous Cycle SGs are Low Frequency Oscillators (LFOs), with Frequency and Trigger input columns in the matrix:

**Continuous Cycle** - the SG triggers on the positive edge of T (T≤0 to T>0) and continues as long as T≥0.

**Single Cycle** - the SG triggers on the positive edge of T and completes one cycle unless T<0 stops it.

Dual SGs are a pair of Low Frequency Oscillators (LFOs), with a pair of Frequency columns in the matrix:

**Dual** - both SGs trigger on finger touch, and complete one cycle.

**Phase from Amplitude** - the SG's phase is supplied directly by the P column. Phase from Amplitude SGs are Low Frequency Waveshapers (LFWs), with a Phase input column in the matrix. Values should be in the range 0 to 1. Values over 1 are clipped at 1. Values below 0 act as absolute values and show the same behavior as positive ones. Note: The SG phase is the RMS value of the P column computed each millisecond.

It is possible to retrigger Continuous Cycle and Single Cycle SGs without stopping them first. For example, a Continuous Cycle SG with this sequence of T values retriggers without stopping: T=0,1,0,1. This sequence stops the SG before triggering it again: T=0,1,-1,1.

The Continuous Cycle and Single Cycle SG's F and T columns control the frequency and the triggering of each SG, but not the shape of the SG. Any SG shape can be selected by a formula that uses an SG; each formula using the same SG can select different SG shapes. Also, each formula may select different phase offsets and phase modulations for its SG, for quadrature operation and shape modulation.

Phase from Amplitude SGs can be used to implement an amplitude follower. Connect the audio-rate signal to be followed to the SG's P column. Then select this SG in a formula, select a Ramp SG shape, and adjust the formula's persistence and interpolation controls for smooth following.

The Thumbnails tell you which formulas use SGs. If a formula uses an SG, the W in the thumbnail is replaced by the SG number used. Formula B below uses SG1.



### 6.18.1 Shape Generator Use

SGs are defined in the W formula component of a formula. Select the first "dot" control to define one of five shape generators that can be assigned to that W component (here SG 1 is selected). Now W will be controlled by the Shape Generator parameters (shape and phase) defined. The default shape assigned is a ramp up and default phase is 0 radians.

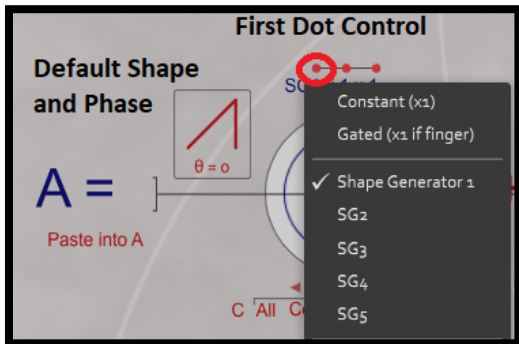

Click the shape control to change to one of the options. The SG Frequency will determine how fast the shape is moved through.

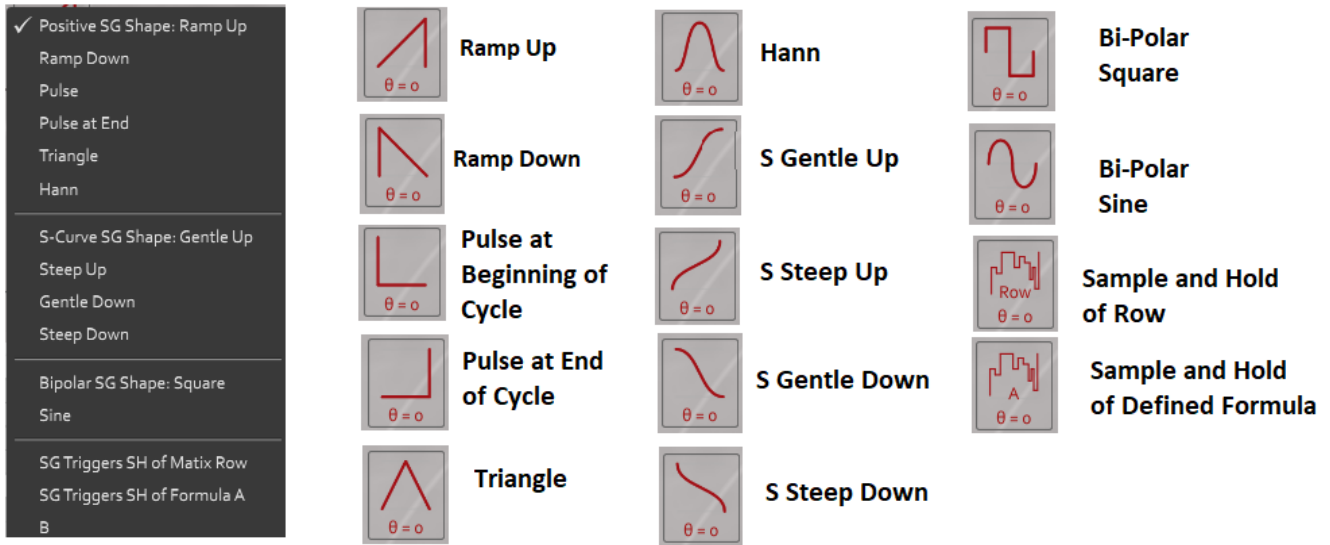

Click the phase control to set phase of the SG. Values include:

- Phase Off (Phase = 0), Default
- Phase = 0.25 (90 degrees out of phase)
- Phase = 0.55 (180 degrees out of phase)
- Phase = 0.75 (270 degrees out of phase)
- Phase Modulation Imposed by a Selected Formula

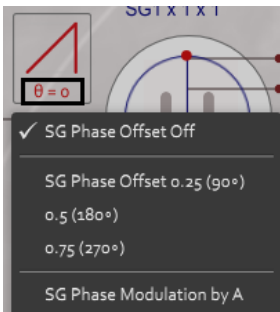

The SG is tied to a speed and trigger and SG type (Continuous Cycle, Single Cycle, Phase from Amplitude or Dual options) as noted above.

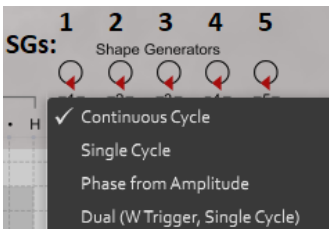

Most uses of the SG are either Single cycle (one trigger of the shape) or Continuous (constant triggering of the shape). Single Cycle shapes are commonly used to create secondary envelopes based on finger gate.

Triggering is controlled by the F (frequency in Hertz) and T (Trigger) columns for each SG. F and T can be constants or formulas. T triggers the SG then its value becomes greater than zero and stops the SG then the value becomes less than or equal to zero. Gating will thus turn the SG on and off and is the most common trigger mechanism.

Here four SGs have been defined (but again remember they have to be assigned to a W component to be used).

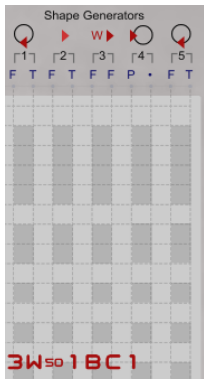

**SG1:** Continuous. F = 3 (3x times a second), T = W (Triggered when fingerboard or EaganMatrix Module is gated)

**SG2:** Single Cycle. F = 0.5 (every two seconds), T=1 (Constant trigger, will always be on, can't determine start)

**SG3:** Dual Trigger. F and T controlled by formulas (See above)

**SG4:** Phase From Amplitude. P=1. T is not used (See above)

### 6.18.2 Simple Example: Adding Fixed Vibrato though SG Sine Modulation (Continuous SG)

A common technique in presets is to add a secondary vibrato using a small amount of sine-based frequency modulation. Of course on the Continuum vibrato is best added with your finger motion but there are cases where you may want to apply some secondary motion as an effect. A continuous SG can be defined for this purpose.

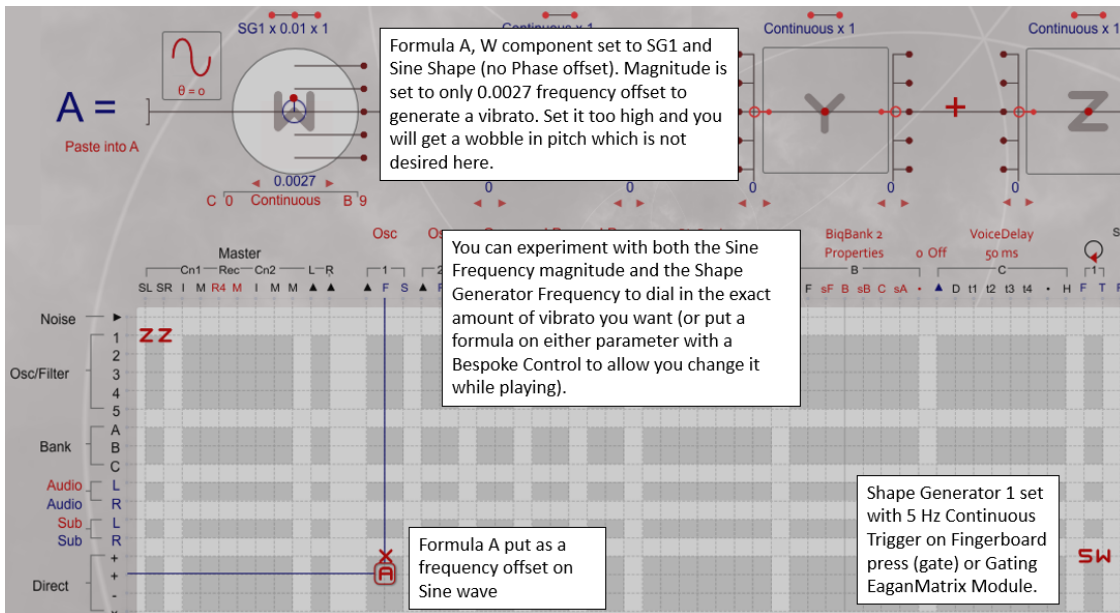

### 6.18.2 Simple Example: Creating Envelope Generator on Gating (Single Cycle SG)

At times you may want to try and create a sharp attack profile (envelope) that dies away quickly that may be difficult by just quickly pressing and releasing the fingerboard. A SG placed on the outputs can be used in this case. A number of System Presets use this technique.

Formula A uses SG1 set to unity (1) with a down ramp. You can use Gentle and steep ramp down to see how that slightly affect the envelope generated.

Formula A is place on the SL/SR output and thus controls the output volume. Because this is set to a very fast down ramp when gated (either through fingerboard or gate on EaganMatrix Module) the result will be to create a single sharp attack every time a gate occurs. This kind of attack can be difficult to create on the fingerboard itself.

Set a Shape Generator 1 to Single Cycle (only once cycle of the shape will be generated on a trigger). Set to a fast frequency (27x a second). This will create a very sharp attack based on the shape used. You can put a Bespoke control on the multiplier to alter the attack profile if you like.

Create a simple Sine Wave with OSC. Standard X for frequency control.

Warning: Be cause using Ramp Up shapes applied to amplitude functions as you can increase to a very high value suddenly. Always turn down your gain when experimenting with ramp shapes. The same can be said when applying sample and hold to noise as that can also create some very loud sounds.



## 7. EaganMatrix Formula Reference

### 7.1. W Component of the Formula

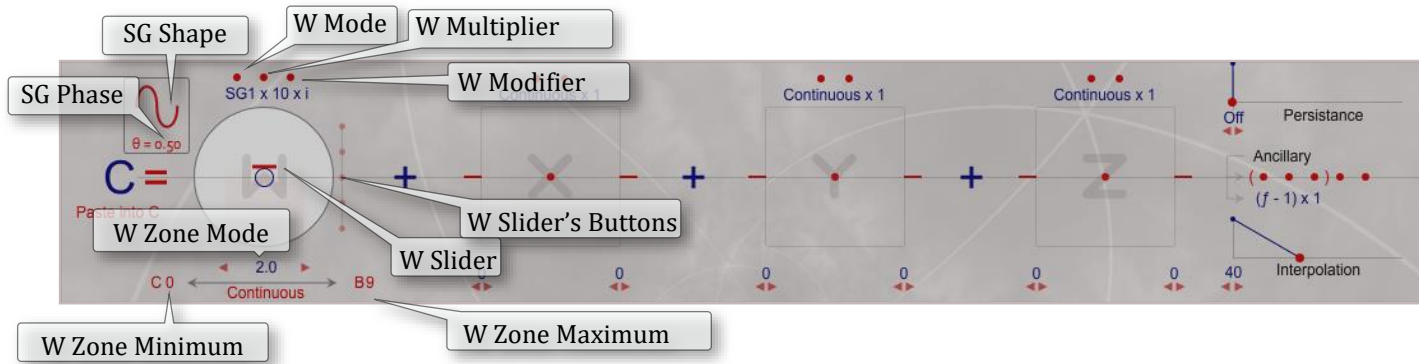

The math for the W component of EaganMatrix formulas is: **W Mode** x **W Slider** x **W Multiplier** x **W Modifier**.

Name	Function
W Slider	<p>A value from -1.0 to 1.27.</p> <p>Note the extra range in the positive direction is very useful in defining constants with high precision in one formula using a Y and/or Z fixed offset. For example the value 1.05946 (twelfth root of 2) is a common constant that might be used. Using W+Y+Z with successively smaller W multipliers this can be achieved in one simple formula.</p> <p>Multiplier: 1 .01 .001</p> <p>1.05 + .0094 + .00006 = 1.05946</p>
W Slider's Buttons	Five buttons allow you to quickly position the W Slider at -1, -0.5, 0, 0.5 or 1 (scaled according to the W multiplier setting).
W Mode	If W Mode is Constant (abbreviated Cons), its value is always 1. If W Mode is Gated, its value is 1 as long as the finger is touching the surface (or W CV input applied on EaganMatrix Module), otherwise its value is 0. If W Mode is SG1...SG5, its value depends on the selected Shape Generator as well as SG Shape and SG Phase. (The triggering, rate, and repetition of the Shape Generator is determined by the Shape Generator's matrix columns, but SG Shape and SG Phase is specific to this formula's use of the Shape Generator.) If W Mode is FormulaDelay, its value depends on the delay tap selected in the W Tap control.

Name	Function
SG Shape	This control only appears if W Mode selects a Shape Generator. Possible SG shapes: increasing ramp (0..1), decreasing ramp (1..0), pulse (1 on, 0 off), pulse at end (0 off, 1 on), triangle (0..1..0), Hann (raised cosine 0..1..0), gentle s-curve up (0..1), steep s-curve up (0..1), gentle s-curve down (1..0), steep s-curve down (1..0), square (1 then -1), sine (min..max -1..1), SampleAndHold matrix row, SampleAndHold Formula A..V. The SampleAndHold are triggered when the Shape Generator initially triggers, and (if it is Continuous Cycle) at each repetition.
SG Phase	This control only appears if W Mode selects a Shape Generator. Select an optional phase offset for this formula's use of the SG: .25 (90 degrees), .5 (180 degrees), .75 (270 degrees), or a value provided by another formula.
W Tap	This control only appears if W Mode is FormulaDelay. W Tap selects output 1..4 in Bank C's FormulaDelay.
W Multiplier	Multiplier on the W component value; choices are .001, .01, .1, 1, 10, 100, 1000.
W Modifier	<p>W Modifier optionally multiplies by control i, ii, iii, iv, v, vi (either range 0..1 or range 0..127) or by voice number.</p> <p>W Modifier "If Voice 1" will equal 1 on voice 1, and 0 on all other voices.</p> <p>W Modifier "Polyphony Scaler" (PScaler) will scale by <math>1/p</math>, where p is the DSP's polyphony (often used with the SummedDelay).</p> <p>W Modifier "Finger Scaler" (FScaler) outputs <math>1/n</math>, where n is the number of fingers on the surface at one time. Originally designed to help with dual note playing on the Mini because of its single Z generating capabilities. It can be used for other interesting effects. For instance when holding three notes down on the surface, Finger Scaler is <math>1/3</math> (0.3333). This can be useful as a scaling multiplier on a column.</p>
W Zone Min/Max	Minimum and Maximum finger pitch for W Zone. The W component's value will be forced to 0 if the finger's pitch is outside of the W Zone. To define a "dead zone", set Minimum>Maximum; then W will be forced to 0 when $Maximum \leq pitch \leq Minimum$ .
W Zone Mode	If W Zone Mode is set to Continuous, the finger pitch movements are checked against the W Zone as long as the finger is in contact with the surface. If W Zone Mode is set to Initial, the finger pitch is checked against the W Zone only once, when the finger first comes in contact with the surface.

## 7.2. X Component of the Formula

The details of the math for the X component are as follows:

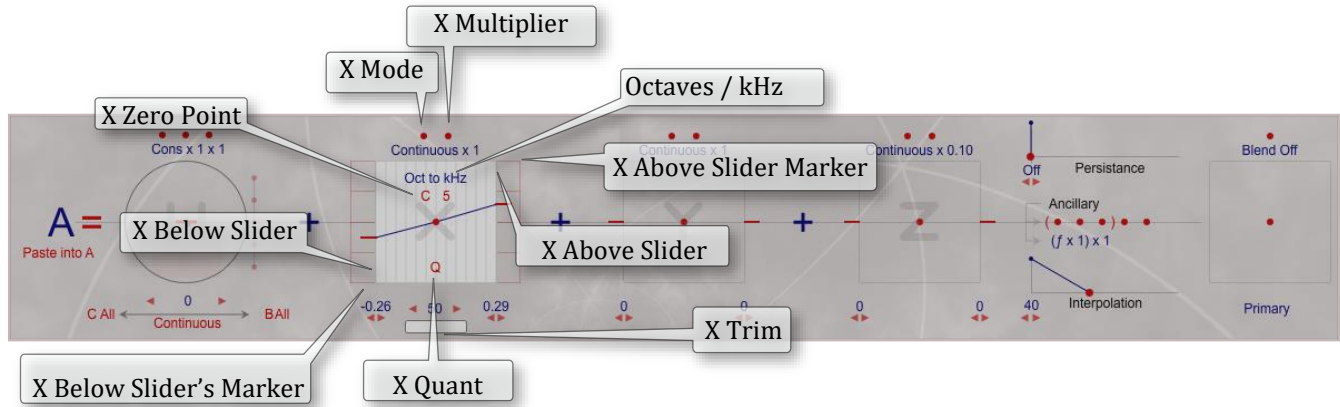

when Octaves is selected:  $(quant (nn - nn_0) \times (X \text{ Slider} + X \text{ Fine}) \times \text{Multiplier}) / 12.0$

when kHz is selected:  $nnToKHz (60.0 + quant (nn - nn_0) \times (X \text{ Slider} + X \text{ Fine}) \times \text{Multiplier})$

where:  $nn$  = pitch of finger in note number units (for example 60.102 is 10.2 cents above middle C)

$nn_0$  = X Zero Point in Midi note number units

$quant ( )$  = optional quantization to Q half steps

X Slider = X Above Slider when  $nn > nn_0$ , otherwise negative of X Below Slider

$nnToKHz ( )$  = converts note number units (60.0 = middle C) to kHz (.26162557 = Middle C)

transfer function selected:  $trans (xx) \times (X \text{ Above Slider} - X \text{ Below Slider}) + X \text{ Below Slider}) \times \text{Multiplier}$

where:  $xx$  = x position of finger; transfer function extends from 3 octaves below Middle C to 3 above

$trans ( )$  = X Transfer Function

Name	Function
X Zero Point	Position on the Continuum surface where the X component of the formula is zero. This is available when Octaves or kHz is selected.
X Below Slider	Change in the X component when the performer's finger is to the left of the X Zero Point. If an X Transfer function is used, this is the value 3 octaves below Middle C.
X Below Markers	Five buttons allow you to quickly position the X Below Slider at -1, -0.5, 0, 0.5 or 1.
X Above Slider	Change in X component when the performer's finger is to the right of the X Zero Point. If an X Transfer function is used, this is the value 3 octaves above Middle C.
X Above Markers	Five markers allow you to quickly view position the X Above Slider at -1, -0.5, 0, 0.5 or 1. Note: As opposed to previous versions, click near the marker to move the cursor to that location and then use the Arrow controls to quickly fine adjust to the exact X minimum and maximum range values desired.  <div style="display: flex; justify-content: space-around; align-items: center;"> <div style="text-align: center;"> <p>X Min</p> <p>-0.26</p> <p>◀▶</p> </div> <div style="text-align: center;"> <p>X Max</p> <p>0.29</p> <p>◀▶</p> </div> </div>

Name	Function
X Quant	X Quant allows you to quantize the X finger position to implement regularly-sized regions on the playing surface. X Quant is normally off. (Note: X Quant is not related to the Round Rate tuning mechanism.)
Octaves / kHz / Transfer Function	The X value may be converted to kHz by selecting "kHz". This is normally selected if the formula appears in a matrix column that controls frequency in kHz. If the formula appears in CVC columns, "Octaves" is used (together with appropriate X Slider values) to generate CVC control voltages in 1 or 1.2 volts-per-octave units. Transfer Functions are available for situations where the formula controls non-pitch synthesis parameters; the available functions are Linear, S, Squared, Square Root, 2 Step, and 3 Step. The twelve horizontal divisions in the transfer function graph correspond to tritones, and the centerline is Middle C; thus the transfer function domain is 3 octaves below middle C to 3 octaves above.
X Trim (Fine)	<p>Trim (old Fine control) allows for fine adjustments on the X Slider values. This is normally 0 but can be used to slightly offset the X Slider values in .05 cent increments. Note: 9.9 editor defaults the zero trim offset point as 50. In 10.x and later this is set in increment of .05 as noted above.</p> 
X Mode	If X Mode is set to Continuous (abbreviated Cnt), the finger X position is tracked and updated continuously as long as the finger is in contact with the surface. If X Mode is set to Initial, the X value is sampled and held when the finger first comes in contact with the surface. If X Mode is Relative, the X value will start at 0 and deviate from that value depending on the current X finger position relative to the starting X finger position. If X Mode is Derivative, the X value will be the finger's X velocity (positive or negative) when the finger is moving, or 0 if the finger stops moving.
X Multiplier	Multiplier on X component value. The multiplier may be .001, .01, .1, 1, 10, 100, 1000.

### 7.3. Y Component of the Formula

The details of the math for the Y component are as follows:

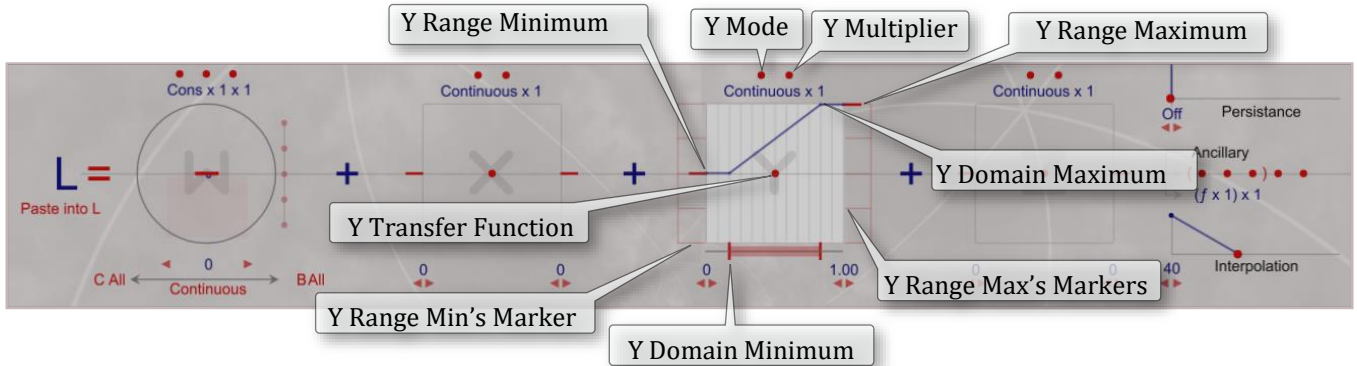

$$(trans(domain(yy)) \times (Y\ Range\ Maximum - Y\ Range\ Minimum) + Y\ Range\ Minimum) \times Y\ Multiplier$$

where: *yy* = front-to-back position of finger, 0.0 is front, 1.0 is back

*domain* ( ) = scaling based on Y Domain Minimum and Y Domain Maximum

*trans* ( ) = Y Transfer Function

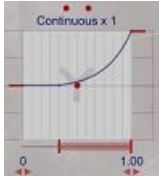
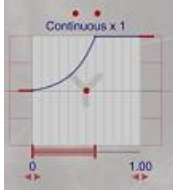

Name	Function
Y Range Minimum	Specifies minimum value for Y transfer function. A draggable bar allows you to easily change the value with fine adjustment using arrow controls. <div style="border: 1px solid black; padding: 5px; display: inline-block;"> <span style="border: 1px solid red; padding: 2px;">Y Min</span>                      Y Max  <span style="border: 1px solid gray; padding: 2px;">0.14</span>                      <span style="border: 1px solid gray; padding: 2px;">0.30</span> </div>
Y Range Min's Markers	Five markers allow you to quickly position the Y Range Minimum at -1, -0.5, 0, 0.5 or 1. Use Arrow controls to move to exact Min value desired. <div style="border: 1px solid black; padding: 5px; display: inline-block;"> Y Min                      <span style="border: 1px solid red; padding: 2px;">Y Max</span>  <span style="border: 1px solid gray; padding: 2px;">0.14</span>                      <span style="border: 1px solid gray; padding: 2px;">0.30</span> </div>
Y Range Maximum	Specifies maximum value for Y transfer function. A draggable bar allows you to easily change the value with fine adjustment using arrow controls.

Name	Function
Y Range Max's Markers	Five buttons allow you to quickly position the Y Range Maximum at -1, -0.5, 0, 0.5 or 1.
Y Domain Minimum	<p>Specifies the finger's Y value at which the Y transfer function will reach minimum. A bottom adjustable slider is used to set the minimum and maximum domain (using Shift-Drag of the slider). The following example has Y min set at 0 with the Doman slider minimum set to almost half of the range of Y (starting Mid Y) and the domain max slider is set to its full/rightmost position allowing the exponential transfer function to start a bit before middle of Y moving to Y max = 1.0 at top of Y.</p> 
Y Domain Maximum	<p>Specifies the finger's Y value at which the Y transfer function will reach maximum. A bottom adjustable slider is used to set the minimum and maximum domain (using Shift-Drag of the slider). This example does the reverse of the previous one. Y Min = 0.0 and Y Max = 1.0 as above, however not the Y domain starts at its minimum position and ends about halfway up Y, in effect allowing the squared transfer function to start at bottom of Y and finish at mid Y where it remains until top of Y.</p> 
Y Transfer Function	The Y Transfer Function affects the slope of the minimum to maximum Y value. The available slopes are Linear, S, Squared, Square Root, 2 Step, and 3 Step.
Y Mode	If Y Mode is set to Continuous (abbreviated Cnt), the finger Y position is tracked and updated continuously as long as the finger is in contact with the surface. If Y Mode is set to Initial, the Y value is sampled and held when the finger first comes in contact with the surface. If Y Mode is Relative, the Y value will start at 0 and deviate from that value depending on the current Y finger position relative to the starting Y finger position. If Y Mode is Derivative, the Y value will be the finger's Y velocity (positive or negative) when the finger is moving, or 0 if the finger stops moving.
Y Multiplier	Multiplier on Y component value. The multiplier may be .001, .01, .1, 1, 10, 100, 1000.

**Osmost Note:** The Osmost does not use Y as a vertical control. Y is interpreted rather like Aftertouch as follows. As you depress a key Z will move from 0 to 1. Y if programmed in the EaganMatrix will remain at 0 for this motion. After Z = 1 you can continue to press the key and a different response will be felt and then this special "Aftertouch" function will engage. At this transition point Y moves from 0 to 1 as you continue to depress the key until you reach the bottom of the key bed. Some very unique effects can be produced with this function.

## 7.4. Z Component of the Formula

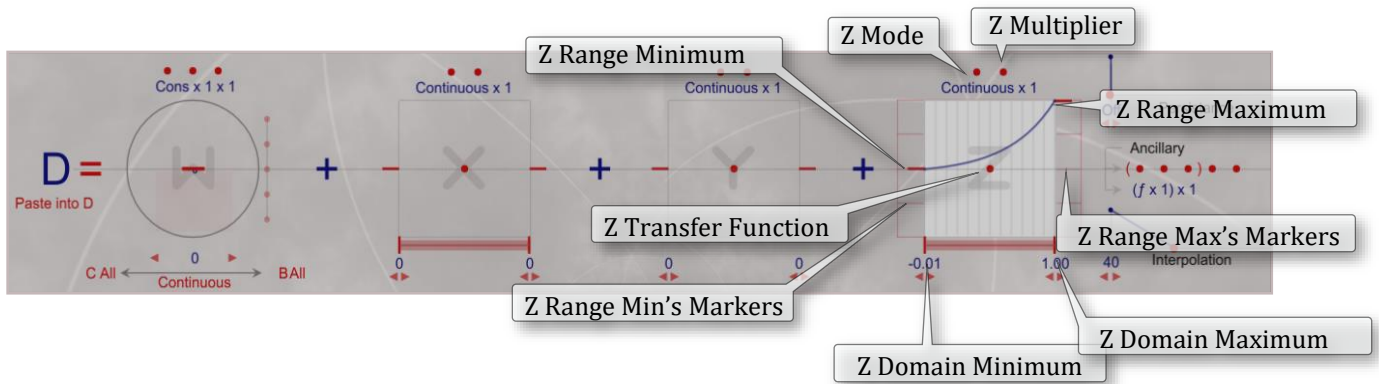

The details of the math for the Z component are as follows:



**(*trans* (domain (zz)) × (Z Range Maximum - Z Range Minimum) + Z Range Minimum) × Z Multiplier**

where: zz = pressure of finger, 0.0 to 1.0,

*domain* () = scaling based on Z Domain Minimum and Z Domain Maximum

*trans* () = Z Transfer Function

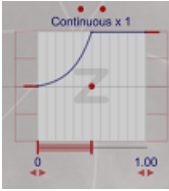

Name	Function
Z Range Minimum	Specifies minimum value for Z transfer function. Set with a slider and arrow keys to easily move to exact value.
Z Range Min's Markers	Five markers allow you to quickly position the Z Range Minimum at -1, -0.5, 0, 0.5 or 1. Move to exact value using slider or arrow controls.
Z Range Maximum	Specifies maximum value for Z transfer function.
Z Range Max's Markers	Five markers allow you to quickly position the Z Range Maximum at -1, -0.5, 0, 0.5 or 1. Move to exact value using slider or arrow controls.
Z Domain Minimum	Specifies the finger's Z value at which the Z transfer function will reach minimum. Set with a slider control at the bottom (use Shift-Drag to set end points). Works like Y domain control described above. For example, here Min Z is set to 0.0 with Min domain full left and Max domain set to half Z pressure point. When Z is pressed the value will move from 0.0 to max value = 1.0 with Z halfway depressed.

Name	Function
	
Z Domain Maximum	<p>Specifies the finger's Z value at which the Z transfer function will reach maximum. Set with a slider control at the bottom (use Shift-Drag to set end points). Works like Y domain control described above.</p> <p>In this example Min Z is set &gt; Max Z, which is perfectly acceptable. The Min Domain is set far left with Max Domain set halfway. Z in this case will be set to 1.0 without any pressure on Z and as you press Z, Z will get to 0.0 at half pressure. Beware of using formulas that start Z at non-zero values if they are being used to control volume functions as the Z value if not scaled to zero through a W gate will start off at the given value even though you are not pressing the fingerboard.</p> 
Z Transfer Function	<p>The Z Transfer Function affects the slope of the minimum to maximum Z value. The available slopes are Linear, S, Squared, Square Root, 2 Step, and 3 Step.</p>
Z Mode	<p>If Z Mode is set to Continuous (abbreviated Cnt), the finger Z position is tracked and updated continuously as long as the finger is in contact with the surface. If Z Mode is set to Initial, the Z value is sampled and held when the finger first comes in contact with the surface. If Z Mode is Derivative, the Z value will be the finger's Z velocity (positive or negative) when the finger is moving, or 0 if the finger stops moving. If Z mode is Release Only, a release pulse is generated when the finger is lifted (select "finger lift") or when sustain/sostenuto is ended (select "sus/sost pedal end"). A formula can use Release Only combined with high persistence to create finger-lift noise.</p>
Z Multiplier	<p>Multiplier on Z component value. The multiplier may be .001, .01, .1, 1, 10, 100, 1000.</p>

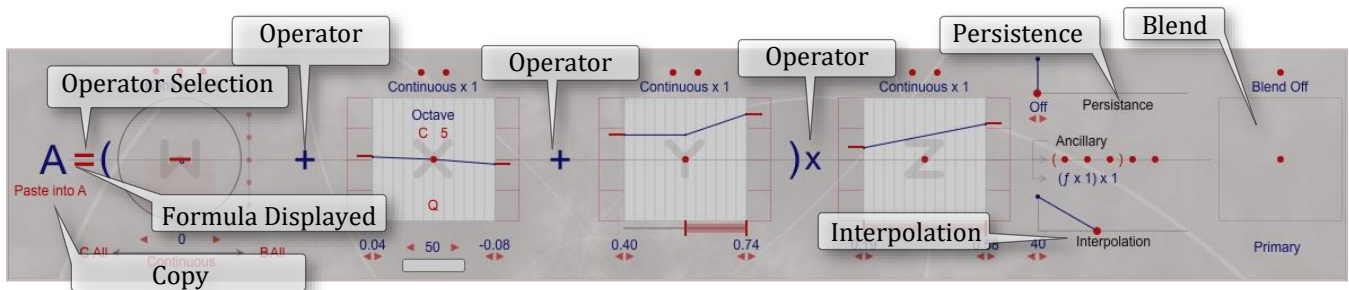

## 7.5. Other Parts of the Formula

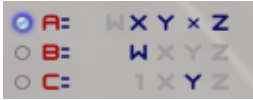
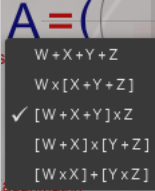

Name	Function
Formula Displayed	<p>Identifies the formula currently displayed. To choose a different formula, click on the matrix, on the formula thumbnails.</p> 
Show Value	<p>A numeric readout is toggled by clicking the red Show Value circle. The readout may be for the formula's value, or the value of the matrix column in which the formula appears. For Continuums with CEE, only the first DSP plays notes when Show Value is active.</p>
Copy	<p>Copy another formula definition. This will replace the formula definition displayed with a copy of another formula definition. You can copy the user-defined formulas (A-V), pre-defined formulas (W-Z), or a constant.</p>
Operator Selection	<p>Determines what math (operator selection) is used to combine the components of the formula. The most common choice is <math>W + X + Y + Z</math>. Other choices are <math>W \times (X + Y + Z)</math>, <math>(W + X + Y) \times Z</math>, <math>(W + X) \times (Y + Z)</math>, and <math>(W \times X) + (Y \times Z)</math>. Note: Previous versions of the editor allowed you to change this by selecting any of the operators. As of 9.8 and later, operator selections are all made from the leftmost "=" control.</p> 
Persistence	<p>Slows down decreases in formula value. This only affects decreases in formula value, not increases. If Persistence is off (0), the formula decreases are not slowed down. If the Persistence is large, the formula decreases slowly. This can add a sustain effect in many presets.</p> 
Interpolation	<p>Smooths changes in formula value. Unlike Persistence, this affects both decreases and increases in formula value. If Interpolation is off (0), the formula values are not smoothed at all (stepwise evaluation), and in many cases noise or aliasing will result. Most commonly the Interpolation is set around 40, to give fast response without introducing stepping artifacts. If the Interpolation is large, the formula changes slowly.</p> 

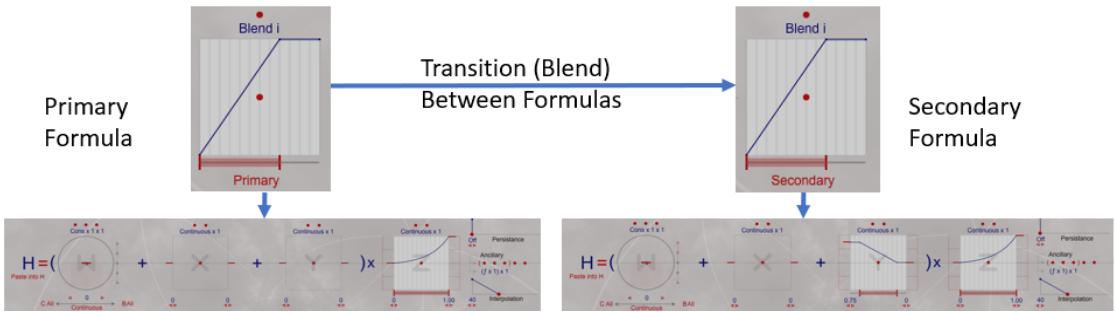
Name	Function
<p>Blend</p> 	<p>Specifies a blend between primary and secondary values for the formula's W Slider, X Range Min/Max, Y Range Min/Max, Z Range Min/Max, Persistence, and Modulation. The Blend may be controlled by user-defined formulas A..V, by controls I .. vi, or by Ch1 (0 if internal from playing surface, 1 if Midi from keyboard or sequencer on MPE+ Channel 1). If no blend is specified, only primary values are used. When a blend is specified, the secondary values may be viewed by clicking on the primary/secondary toggle.</p> <p>The Blend function has three components:</p> <ol style="list-style-type: none"> <li>1. Primary Formula</li> <li>2. Secondary Formula</li> <li>3. Transition function (blend) between the two formulas</li> </ol> 

## 7.6. Ancillary Operator Mechanism (Primary and Secondary Ancillary Functions)

The Ancillary Operator Mechanism consists of five menus selected by red dots (that have tool tips when hovering). The

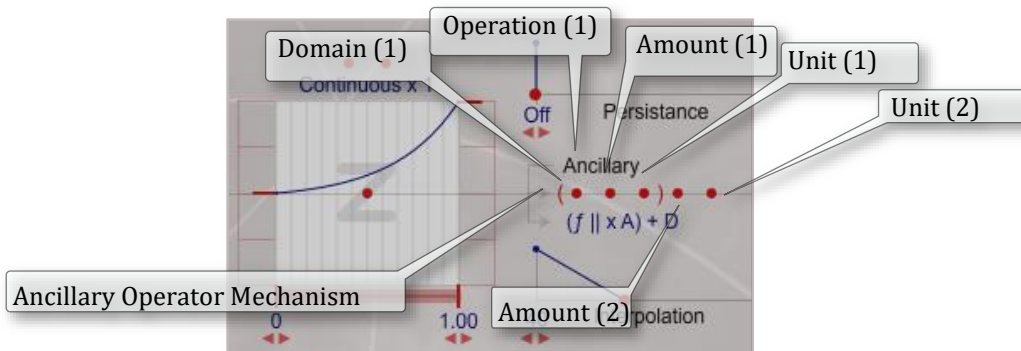

first three dots (in parentheses) apply the primary ancillary operation. The second two dots (new in firmware 9.8 and later) allow you to apply a secondary ancillary function greatly increasing the mathematical operation options available for the formula.

- The **Domain** menu selects which components of the formula are affected (all components, or only W, X, Y, or Z). It also has options to evaluate the formula (on all voices) using Voice 1's WXYZ values or using the Touch Area's WXYZ

values. It also include new graphing operations (see new Graph mode). Finally it include Note conversion options and Matrix Column Limiting options,

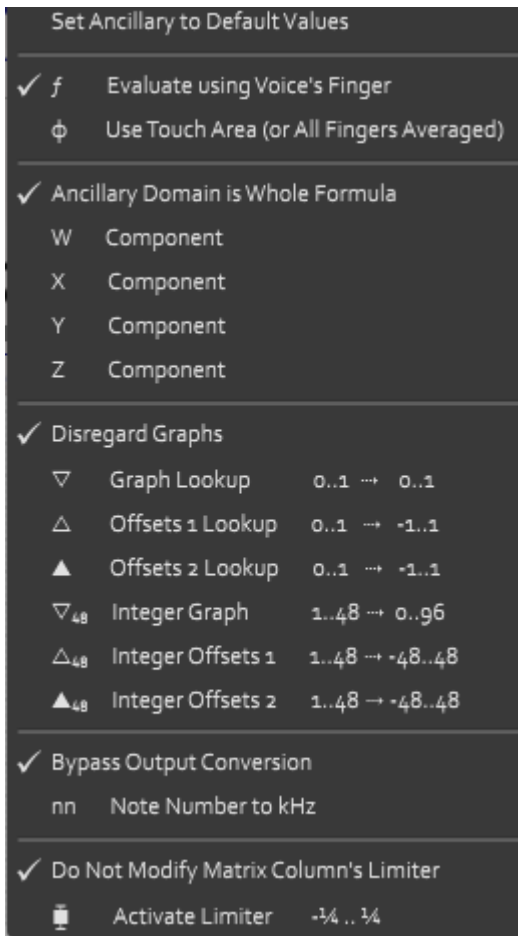

- The **Operation** menu selects a mathematical operation. Default is Multiply.

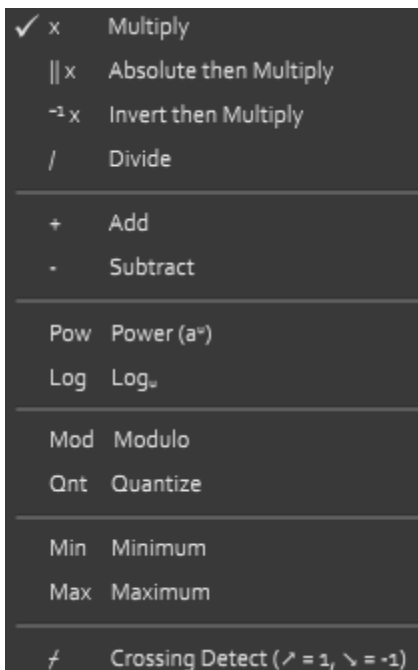

- The Amount menu selects a constant, formula, or the Midi clock (normalized to 1.0 for 120 quarters per minute). Default amount is 1, with the default multiply operation, defaults Ancillary to the original formula.

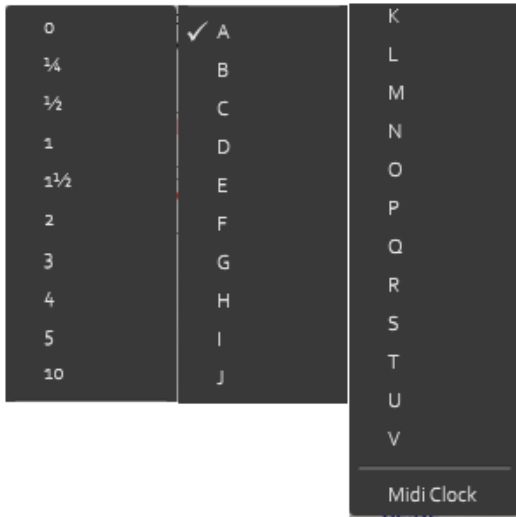

- The Unit Conversion menu selects “No Unit Conversion” (no change to the formula’s value), or conversion from note number (nn=60 for middle C) to kHz (0.2616 for Middle C).

If A stands for the formula being edited, and B stands for the constant/formula/Midi clock value, these are possible:

AxB, |A|xB, (1xA)xB, A+B, A<sup>B</sup>, log<sub>B</sub>A, A mod B, A quant B, A crosses B, min(A,B), max(A,B)

where: A mod B is the remainder of A divided by B.  
 A quant B is A-(A mod B), or “A quantized to B”.  
 A crosses B is 1 if A>B when previously A<B, or A<B when previously A>B.

The Ancillary Operator Mechanism has no effect with “x 1” (multiply by constant 1), the default for a formula.

**Via Limiter:** Selecting “Via Limiter” will result in special processing for any matrix point where the formula appears: the formula x row value will be hard-clipped to -1/4..1/4.

A special use for Via Limiter is in the first two matrix columns, which feed into the Master Section’s saturation waveshaper. The limiter together with this waveshaper results in soft clipping, with a sine  $-\pi/2.. \pi/2$  transfer function. Without the limiter, very loud EaganMatrix output in the first two columns will be sinusoidally waveshaped, also a useful overload saturation effect.

**Technical details about evaluating each column in a matrix:** First, each formula in the column that has “Via Limiter” is multiplied by its matrix row; the sum of these is clipped to the range -1/4..1/4; then other formulas in the column are multiplied by their matrix rows; the sum of these is added to the Limiter result; finally that result is multiplied by the formula (if any) in the column’s Multiply row. For example, if formulas  $f_1$  and  $f_2$  have “Via Limiter”,  $f_3$  and  $f_4$  are other formulas in the column, and  $f_5$  is in the column’s Multiply row:

$$\text{columnValue} = (\text{clip}(f_1 \cdot \text{row}_1 + f_2 \cdot \text{row}_2) + f_3 \cdot \text{row}_3 + f_4 \cdot \text{row}_4) \times f_5$$

New to firmware 9.8 and later is the secondary Ancillary function:

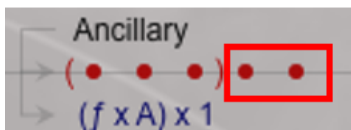

This allow you apply a second ancillary operation to the first. The two additional selectable dots allow you to define a second operation and Amount that will be applied to the result of the first ancillary operation. These default to Operation = Multiply and Amount = 1 (that is multiple by 1 so it has not effect).

### 7.6.1 Graph Programming (Ancillary Formulas)

Firmware 9.9 and later includes a new Integer Graphing function that allows the user to define an Integer Graph with optional primary and secondary integer offsets that can be used to create note and other numerical patterns up to 48 values long. These are the same graphs used by the BiqGraph, but they are interpreted differently based on the operations selected and applied. This can create, for example, note sequences that you can manipulate in various ways by dynamically altering the length, speed and to limited extent note content of the pattern. It's not a sequencer but can create some similar affects.

The three graphing options are available on the Control Panel Selections under C1, C3, C3. They are linked to new Ancillary formula operations and depending on if the formula is associated with BiqGraph or Integer Graph, the values in the graph will be interpreted differently: 0..1 floating values (graph lookup) or 1-48 Integer values (integer graphs) for non BiqBank usage or 0..1/-1..+1 (offsets), 0..96/-48..+48 (offsets) for BiqGraph usage. The default Ancillary setting is to Disregard Graphs. You can select/program one of six Graphing options for use in a formula:

- Graph Look up – Float lookup 0..1 or BiqGraph Lookup 0..1
- Offsets 1 Lookup – Float lookup 0..1 or BiqGraph Lookup -1..+1
- Offsets 2 Lookup – Float lookup 0..1 or BiqGraph Lookup -1..+1
- Integer Graph – Integer Use 1..48 or BiqGraph Use 0..96
- Integer Offsets 1 - Integer Use 1..48 or BiqGraph Use 48..+48
- Integer Offsets 2 - Integer Use 1..48 or BiqGraph Use 48..+48

**New Graphing Options**

	<div style="border: 1px solid gray; padding: 5px; display: inline-block;">                 Ancillary  <input checked="" type="radio"/> <input type="radio"/> <input type="radio"/> <input type="radio"/> <input type="radio"/> <input type="radio"/> <input type="radio"/> </div>	
	<div style="border: 1px solid gray; padding: 5px; display: inline-block;">                 Disregard Graphs             </div>	Graphing Disabled (Default)
	▽ Graph Lookup    0..1 → 0..1	Interpret Float 0..1 or BiqGraph 0..1, -1..+1
	△ Offsets 1 Lookup    0..1 → -1..1	Interpret Float 0..1 or BiqGraph 0..1, -1..+1
	▲ Offsets 2 Lookup    0..1 → -1..1	Interpret Float 0..1 or BiqGraph 0..1, -1..+1
	▽ <sub>48</sub> Integer Graph    1..48 → 0..96	Interpret Integer 1..48 or BiqGraph 0..96, -48..+48
	△ <sub>48</sub> Integer Offsets 1    1..48 → +48..48	Interpret Integer 1..48 or BiqGraph 0..96, -48..+48
	▲ <sub>48</sub> Integer Offsets 2    1..48 → +48..48	Interpret Integer 1..48 or BiqGraph 0..96, -48..+48
	Integer Graph         BiqGraph	

Formula 1 ● C1 ● C2 ● C3 Integer Graph Integer Offsets 1 Integer Offsets 2	<div style="border: 1px solid red; padding: 5px; display: inline-block;">                 ▽                  △                  ▲             </div>	
--	--	--

#### Use Case 1: Example of Basic Integer Graph with a Fixed Note Pattern

The most basic use case for the Integer Graphing function is to create a note sequence. Note that this is not to be thought of as a Midi sequencer as the types of operations imposed are going to for the most part be limited to what you can do with shape generator based control as opposed to operations that typical sequencers support. To program a simple note pattern do the following:

1. Create a graph with 1-48 values in the range 0..96. If you place your cursor on one of the hash indicators, the corresponding value will appear at the top of the graph showing you the index of the note in the pattern

and its Integer and BiqGraph values.  $V = (\text{index}) = \text{Int Value} = -\text{BiqGraph Value}$ . The integer value (24 in the example below) will then be integrated as a Midi Note.

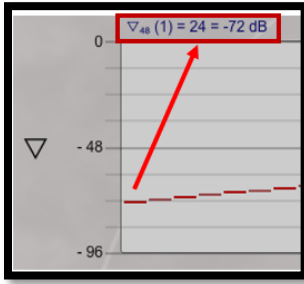

2. In the above case the pattern begins on value 24 and increases by 1 for the seven values shown. A formula will then be created to use the values (in an Ancillary formula) as Midi Note numbers (nn) that will be converted to KHz when applied as the frequency to an Oscillator. Since Midi note numbers 24, 25, 26, 27, 28, 28 and 30 show above will be very low tones, this example offsets them with a Y constant of 21, so the start of the pattern will generate the Midi note numbers (45-A2, 46-A#2, 47-B2, 48-C3, etc.). Note that we could have started the sequence as higher integers in the graph if no offset was desired.
3. To play the notes, a formula (formula I in the example below) is created that sets a ramping shape generator up on W running from value 1 to 48 (so it will run through the full pattern). A Macro Controller is placed on W so that you can control the range of W motion, which will in turn limit how many notes are played in the pattern. That controller might be dynamically changed during performance to create pattern variation. Set a Macro Controller on the Frequency of the Shape Generator to allow for changing speed of the pattern.
4. In this case the pattern will always start on the same note no matter where you press on the fingerboard. If you want to start the pattern based on finger position, add an X offset into the formula scaled to Midi notes.
5. You cannot dynamically change the values in the graph during performance, but you can apply different SG shapes perhaps in different ranges of the fingerboard, alter pattern speed, use sample and hold shape to randomize the pattern, add numeric and also graph offsets in various ways (see below), etc. Lots of ways to use this pattern generation function, but again, it's not a traditional sequencer.

**Simple Integer Graph Example – Will play an Integer Sequence of Midi Note Values On A2 On Fingerboard Gate (Press)**

W Sets Shape Generator Ramp cyclin through values 0 to 48 based on Macro Controller i. Controller "i" will set length of pattern played starting at beginning = 0.

Ancillary uses Integer Graph (set values 1=48) converting Midi Note (nn) to KHz

Integer Pattern Starting on Value=24 (Midi Note 24 offset by Y=21 = nn45 = A2. Note pattern then starts on A2.

Pattern starts in 1/2 Steps going to whole steps to 3rds and then an assortment of descending intervals. Placed on Oscillator Frequency.

Continuous Shape Generator triggered by W Gate with Frequency (Speed) changed by Macro Controller ii.

OSC1

Integer Graph 1.48 -- 0.96

DW

**Use Case 2: Example of Note Pattern Generation using Integer Offset Graphs and X Control**

More complex use cases for note graphing can be created by using one or more offset graphs. A simple method for doing that is as follows.

Set the main graph to all zero values. The offsets graphs will be based off of that.

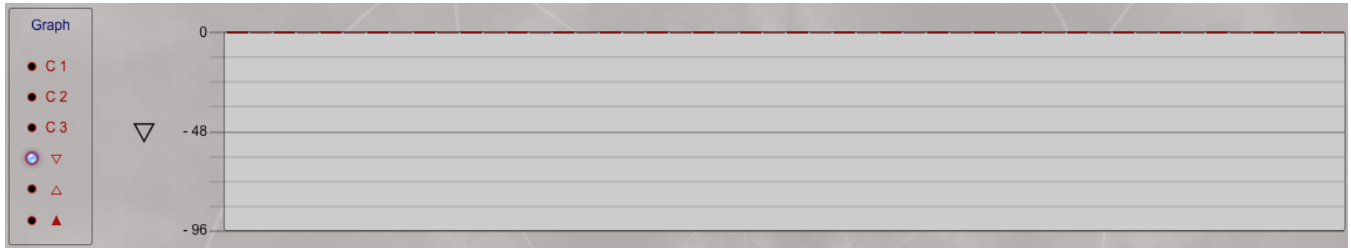

In the primary offset graph set a pattern of values in the range 0 to 48, though we will limit the values to a range that maps to a melodic pattern we wish to generate. A value of 1 added to the base graph value of zero will thus create a note when we program it one half step above the base frequency played. A value of 2 in the offset graph will create a whole step, etc. Create a note patten as desired.

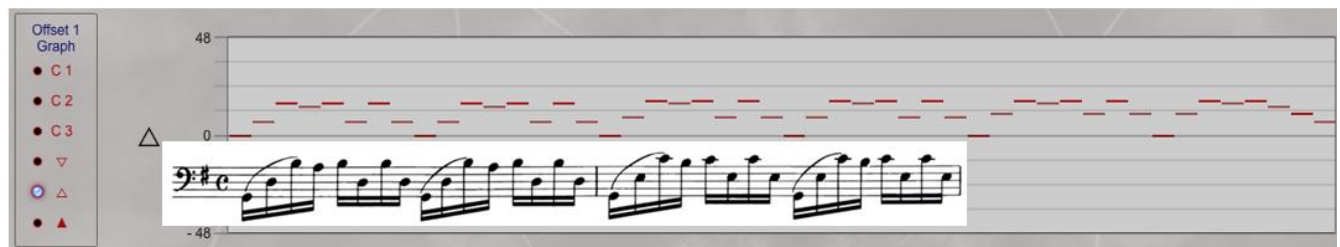

The 48 note pattern created here maps to the opening notes of the Prelude of Bach's Solo Cello Suite in G (actual starting pitch will be determined by X). Compare the first 32 notes of the pattern above to the first 32 notes of the piece overlaid on it.

Note that the note generation in this case applies a different pitch to each pulse that will get generated from the SG. If you want to create note values that last for 2 or 3 times the pulse, you can duplicate values you want to lengthen and create some interesting syncopated patterns in that manner. For example duplicating a few notes in the original pattern creates the following:

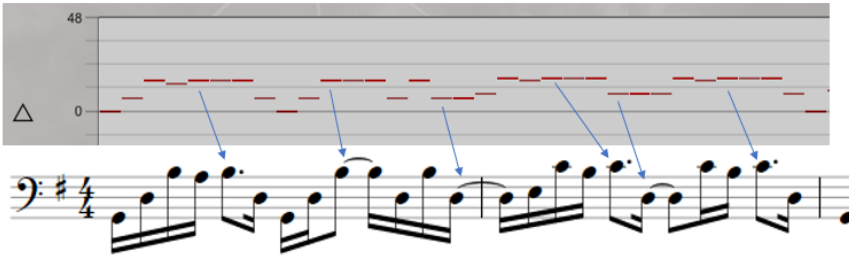

Now that we have created a note pattern, the next step is to apply this to control the frequency of an oscillator (simple sine wave in this example) and use a Shape Generator to create the pattern that will cycle through the note values – as in the first use case. We will use a simple Z pressure function to output the oscillator to the Master Section on SL/SR.

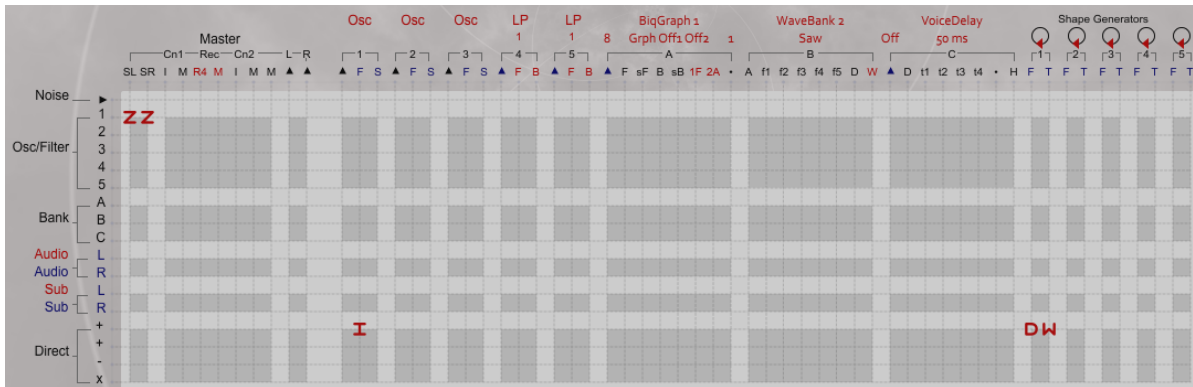

Formula I does the following:

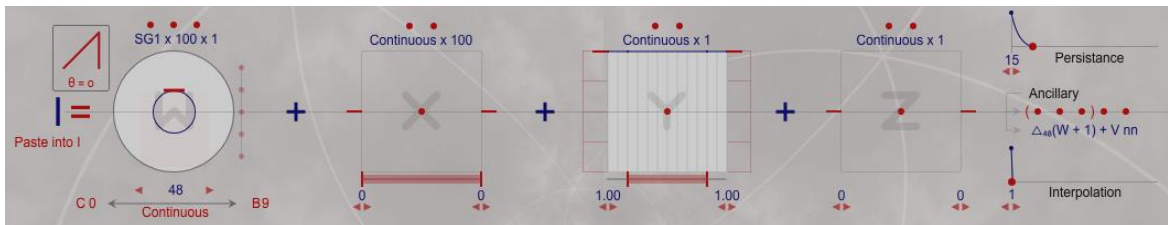

1. It uses a Shape Generator to ramp through the values from 0 to 48
2. Applies the Ancillary function to now use Integer Offsets 1, not Integer Graph that is set to zeros.



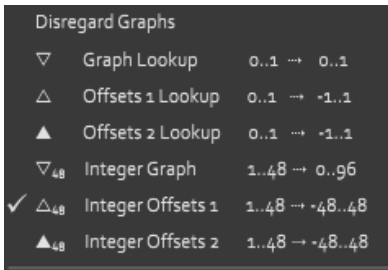

- Then it applies a secondary Ancillary function to apply X scaling based on a formula V (V nn) when you select the Ancillary "Note Number to kHz" option.

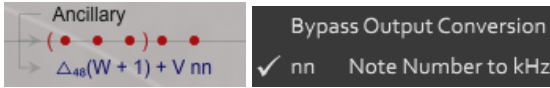

- Formula V basically scales notes played on the fingerboard (X) within a range. Note that it uses Continuous X values as we want to apply integer note values (nn) that will be converted by the ancillary formula nn to KHz applied to the OSC frequency input.

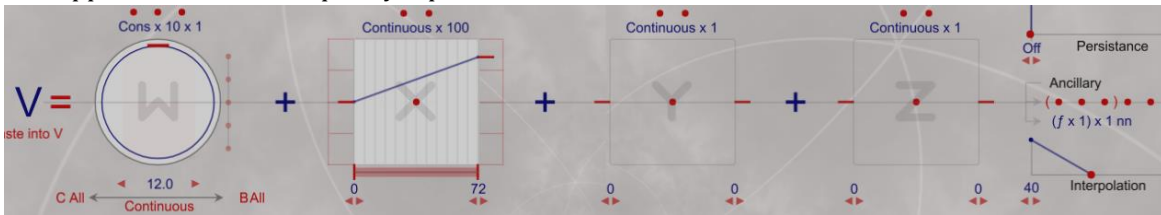

There are lots of options to create interesting patterns that can shift around in various ways. For example, you could apply a second set of graph offsets in some way, perhaps adding them with a Macro Controller to distort the pattern generated by the first set of graph offsets. Have fun with this new function.

## 7.7. Pre-defined Formulas

There are four pre-defined formulas available in the EaganMatrix. Each is a simple way to quickly assign the window, X direction, Y direction, or Z direction of the playing surface in a useful way. When one of these formulas is selected, no formula information will appear below the matrix. These are hard-coded optimized formulas and are not editable.

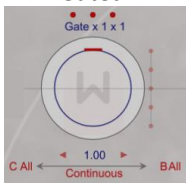
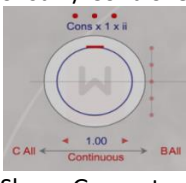
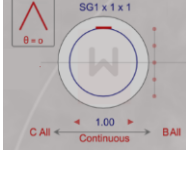
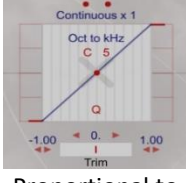
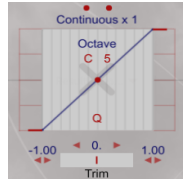
Predefined Formulas		
Formula	Function	User-defined Formula equivalent
<b>W</b>	<p>Defined as either a Gated value of 0 when finger is off surface, 1 when finger is in contact with surface a or a constant value. When a gate, this generates a standard trigger. It can, for instance, be used to trigger a Shape Generator to start at the beginning of a note. Can also be associated with a Macro Controller (commonly used when defined as a constant).</p>	<p>Gated:</p>  <p>Const w/ Controller:</p>  <p>Shape Generator:</p> 
<b>X</b>	<p>Standard pitch control from the X direction per octave (in kHz). Useful in the frequency column of the oscillators, filters, and multipurpose banks. Can defined in Oct converted to kHz or proportional to Octave. Fine pitch trim can be set with the hash underneath using the arrow controls.</p>	<p>Oct to kHz:</p>  <p>Proportional to Octave:</p> 

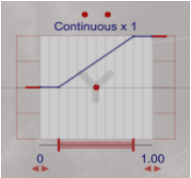
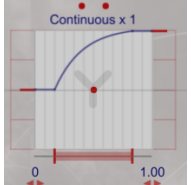
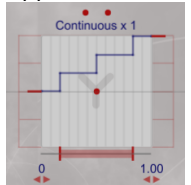
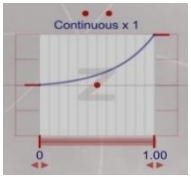
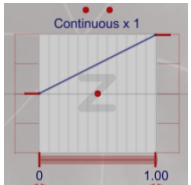
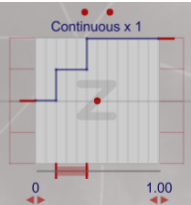
Predefined Formulas		
<p><b>Y</b></p>	<p>Shelved Y value from 0 (at the front) to 1 (at the back). Can be assigned a variety of shapes including a stepped function. Range of values is controlled by the bar underneath (Shift-Drag to change).</p>	<p>Shelved Linear Y:</p>  <p>Non-Linear Function:</p>  <p>Stepped Y Function:</p> 
<p><b>Z</b></p>	<p>Pressure via a squared function from 0 to 1. Useful as the amplitude control of an audio source going into the master section. Can be defined as a variety of non-linear, linear or stepped functions. Range of values is controlled by the bar underneath (Shift-Drag to change).</p>	<p>Non-Linear Z:</p>  <p>Linear Z:</p>  <p>Stepped Z:</p> 

## 7.8. Constant Formulas

Often constants are required in the matrix that cannot be defined with direct numerical entries alone. For example, let's say we need the value 3.551 raised to the power of 0.25. First, 3.551 requires more precision than W (which is most often used to define formulaic constants) will allow. W can only be set to n.n precision when set on the 10x scale factor required, in this case set to 3.5. Y can be used to add in the remaining 0.051 in a formula by setting it to a constant where min = max. Y can be set to scale factor 0.10, setting min and max to 0.51. Y will always be this value regardless of where it is pressed for this formula. Using the default W+X+Y+Z operator setting, this allows W=3.5 to be added to Y=0.051 (=3.551).

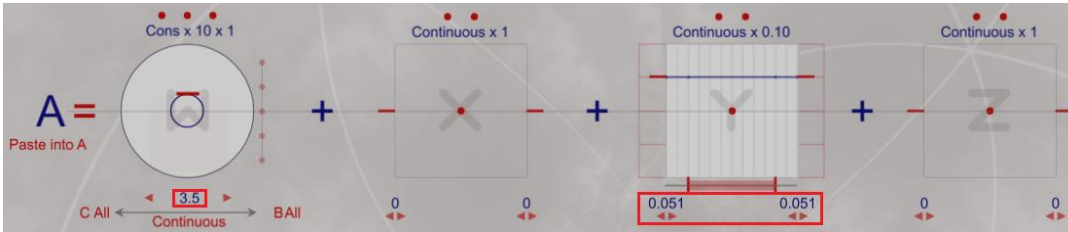

The current value can then be raised to the power of 0.25 using an Ancillary constant. The whole formula needs to be applied in this case so the default Ancillary domain (specified in the first red dot option) can be maintained:

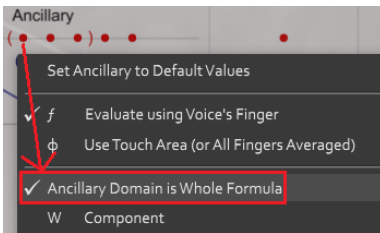

The value is being used as a numeric constant so the default "No Unit" conversion in the first Ancillary option can also be retained:

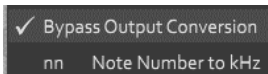

Next select the Power function from the Ancillary "Operation" pulldown (second dot option).

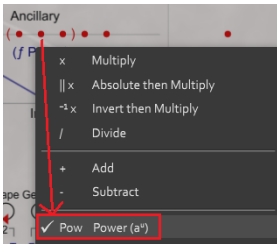

Then select the "Amount" (0.25) from the third Ancillary option (1/2).

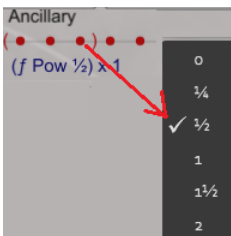

The resulting formula when used in the matrix will produce the result of 3.551 raised to the power of 0.25.

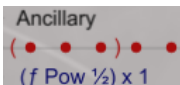

## 7.9. Blend Formula Usage

Many of the presets use the blend function described above to transition (most often smoothly) between a primary and secondary formula defined in the Blend section. As noted above the elements considered in the transition from Primary to Secondary only considers values of W Slider, X Range Min/Max, Y Range Min/Max, Z Range Min/Max, Persistence, and Modulation. Blend can be controlled by a formula, a Macro Controller or much less commonly notes on channel 1. The blend control is located at the rightmost side of each formula. The top dot selects the type of blend. The bottom Primary / Secondary control toggles between the two blend formulas and the bar (Shift-drag) controls the blend transition range.

Defaults Off. Select type of Blend (Blend on Formula, Blend on Macro Controller or Blend all notes on Channel 1)

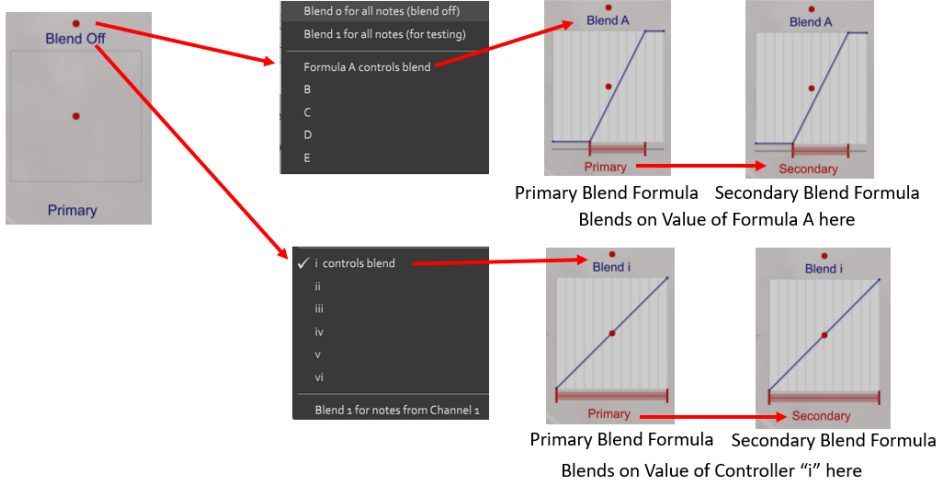

Consider these three blend transition ranges: a smooth linear transition based on the blend control values, a shelved transition range and a transition that only kicks in at the end of the control value range.

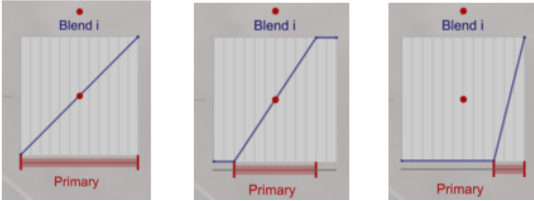

### Blend on Transfer Function (Advanced Programming)

You can also click the center dot to create a blend using a transfer function that includes one of the standard functions and even blend on a Graph.

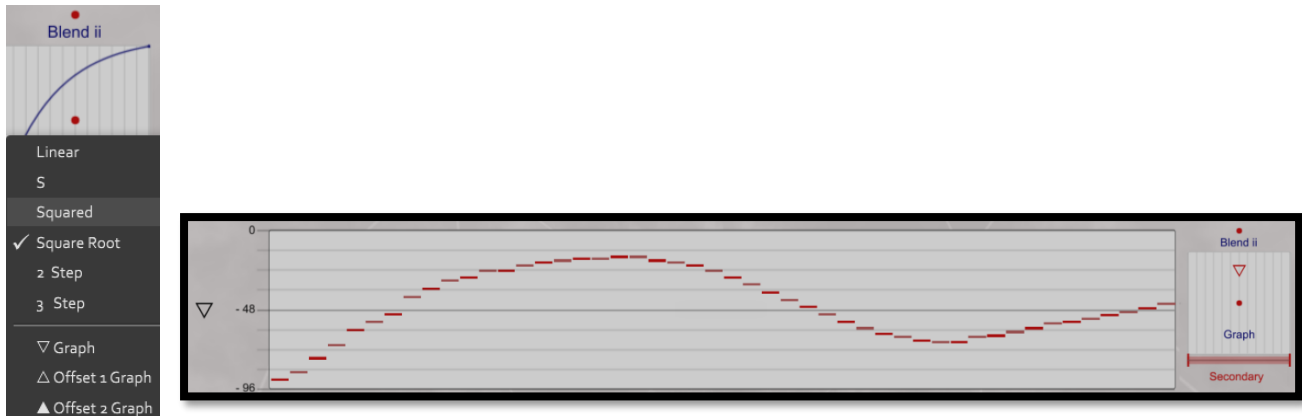

### Control Activated Blend

One of the simplest and most common uses of Blend is to manipulate the transition between the Primary and Secondary formulas with a Control (“i-vi”). This can be seen in the “Grandfather Clock” Preset in Formula C that is used to control the Bandwidth of the noise-pulse driven BiqGraph. Formula C uses a blend based on Control “i” (labelled “Mute”). Other basic functions are noted in the “Grandfather Clock” preset extraction below.

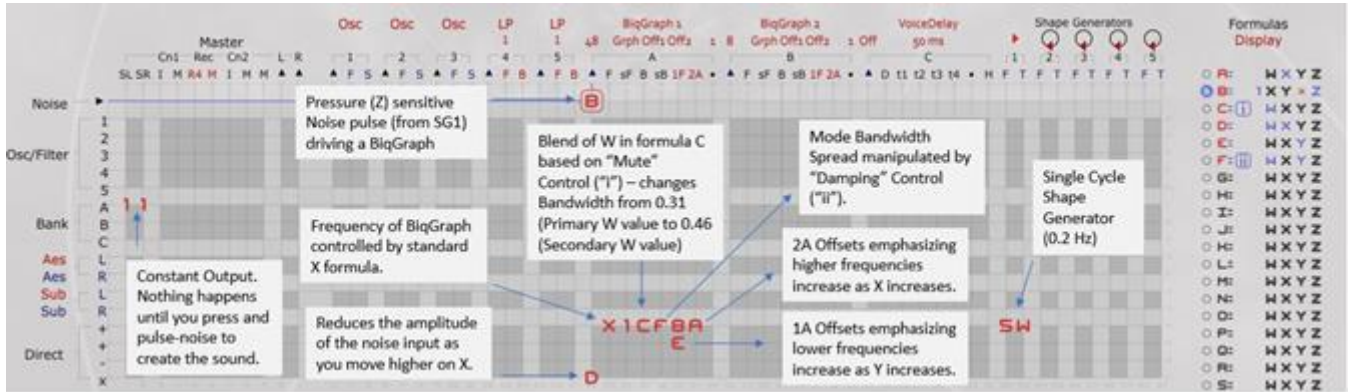

Note the value of W in the C formula. For the Primary function,  $W = 0.31$  and for the Secondary function  $W = 0.46$ . All other components that would be affected by the Blend are not used (and if they were used and set to the same value for the Primary and Secondary, they also would not affect the Blend transition). Blend in formula C is then set so that as the “Mute” Control changes from min to max, the value of W will change with it from a min of 0.31 to a max of 0.46, increasing the Bandwidth of the BiqGraph and effectively muting the sound.

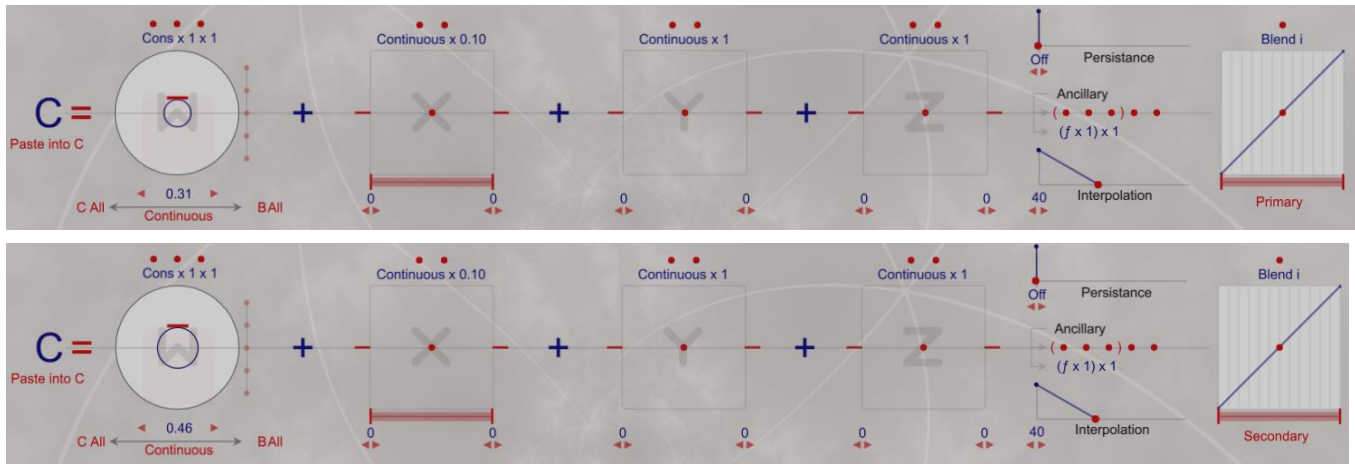

### Formula Activated Blend

A formula is often used to manipulate the blend function instead of a Control, though that formula often contains a control that eventually is performing the Blend transition. One of the most common uses is to blend two Persistence states, one with no or low Persistence and the other with high Persistence. This can be seen in the “Transistor” Preset on formula D that is a Blend controlled by formula I. Here the Primary is set with no Persistence and the Secondary is set to full Persistence.

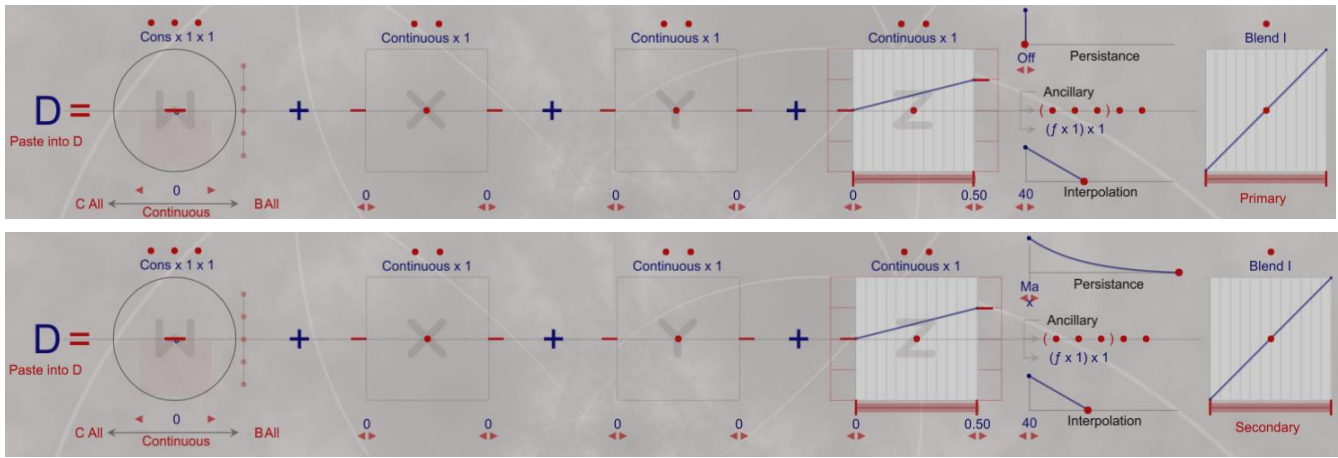

The Blend is controlled by formula I whose W component is in turn manipulated by Control “iv” (labelled “Release”). As Control “iv” is increased it increases W that controls the Blend, increasing Persistence and because formula D is applied to SL/SR, the result will be to add sustain as you increase the “Release” control. This technique is used in numerous presets.

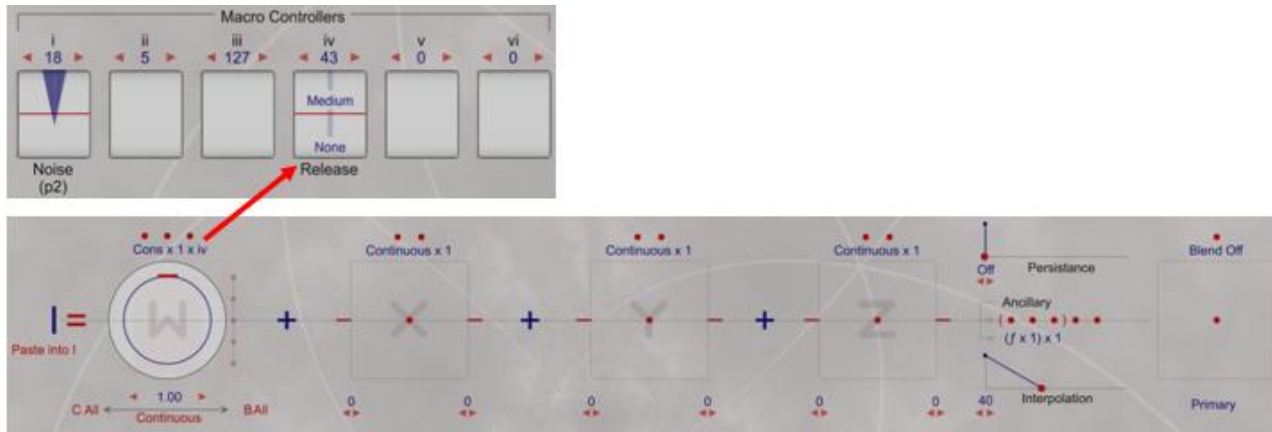

**Ancillary Formula Activated Blend**

Formulas that contain Blend may be defined as Ancillary allowing for a much more complex interrelationship of formulas. Multiple blends can also be used in a single preset. Consider the preset “Cimbalom – Z Pitch”. This uses an Ancillary formula containing a Blend to vary the amount of bend that will be applied through Z. Formula K in this preset controls the pitch of the two Harmonic Manipulators (HarMans) used to create the sound. Formula N is used as a multiplier on the frequency of the second Harman using Control “ii” to apply a detuning factor. Note the X component in formula K is set to Initial as this sound is intended to die away being initiated even if you keep your finger on the fingerboard – a common use for Initial mode which is not used to track continuous finger motion.

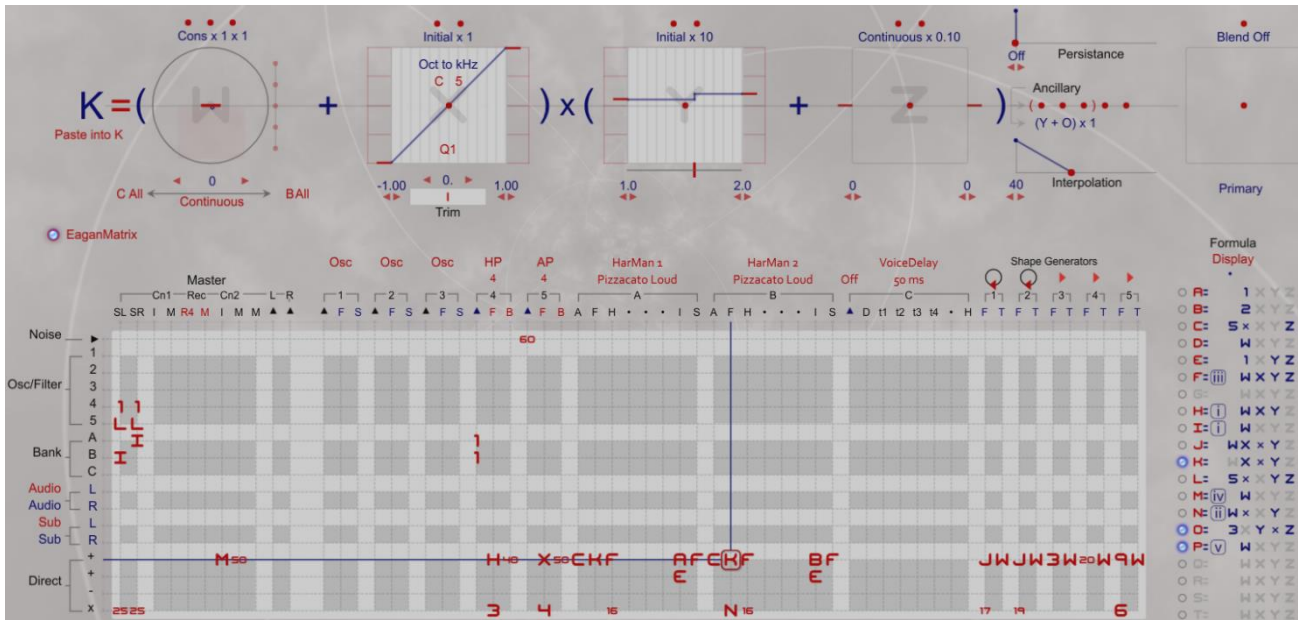

Formula K uses an Ancillary with only the Y component Domain considered using the add operation with formula O (Ancillary Y+O). Y is set to a two-step function also set to Initial. The operator precedence is  $(W + X) \times (Y + Z)$ . Since W and Z are not set, the overall formula then maps to  $(X \times Y)$ . The bottom half of Y is set to 1.0 which when multiplied by X will give the X pitch. The top half of Y is set to 2.0 which when played will then create an octave shift ( $2 \times X$ ).

Ancillary Formula O is a blend controlled by formula P. Formula O's Primary and Secondary change Z (pressure) from nothing in the Primary to unity in the Secondary.

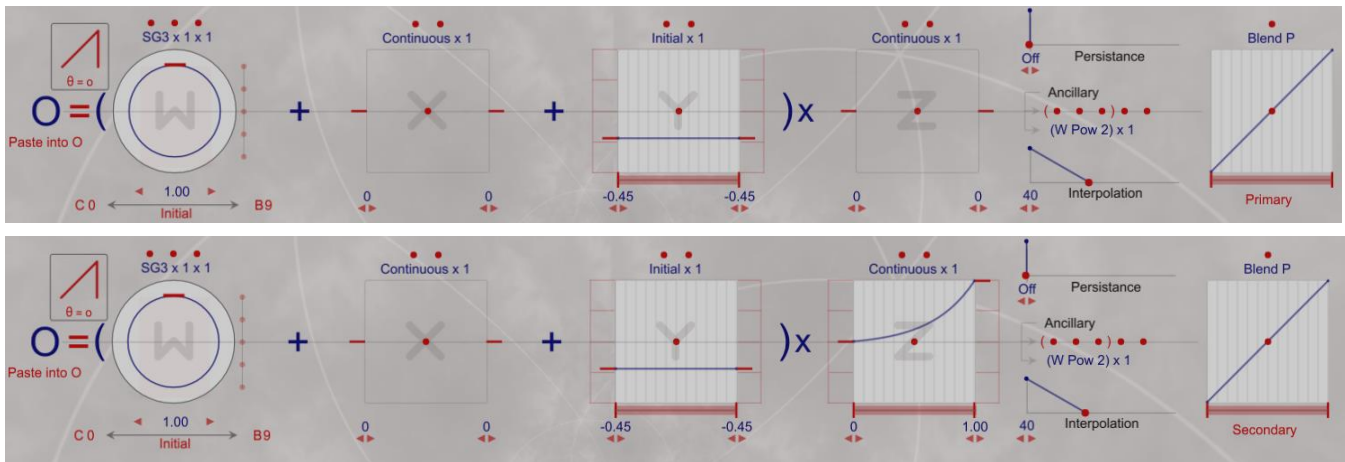

Formula P is controlling the blend of formula O with Control "v" (labelled "BendAmount") which is applied to W in formula P. As the "BendAmount" control increases, W increases which in turn increases formula O's blend from Primary to Secondary which applies more and more pressure output of Z in formula O which in turn is added to the Y component of the original formula K. The end result is that Y gets an additional pressure based offset added to it as the frequency multiplier  $(Y \times X)$  in formula K which create more and more pitch bend offset as the "BendAmount" Control is increased as the performer plays.



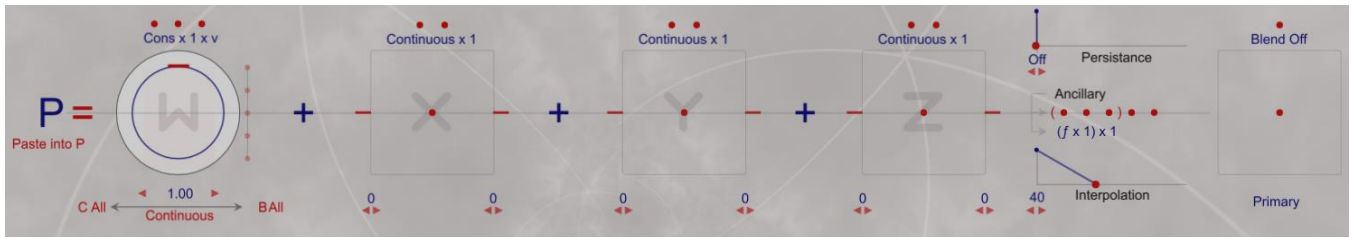

This example is used to illustrate that formulas can be chained using Ancillary and Blend functions and to fully understand some presets, you need to make sure you consider all the formula interrelationships.

### Blend from External Input on Channel 1

A final blend option is available that allows a blend to be based on whether the input is coming from the fingerboard or from an external Midi controller on Channel 1 (ideally one supporting aftertouch for best results). A number of Ch1 system presets use this option, such as “Mountain Slider Ch1” and “Eastern Slider Ch1”. These two presets define an external Chan 1 Blend that affects the Z component based on input source. Although called blend the Ch 1 Blend is really a switch function. When using the fingerboard the Blend formula will use the Primary setting as is. When MIDI from an external controller is detected the Secondary will be used. Look at formula A in either preset. Z is used to control the amount of noise that feeds the BiqBank. When the fingerboard is used the Blend value is 0 which will use the Primary Z function. If the input is from an external Midi controller on Channel 1, the Blend value will be 1 and will use the Secondary Z value (which is much smaller and intended to guard against a loud noise burst that might result from the external controller sending full range aftertouch or CC values on Channel 1 as MIDI keyboards will not have the fine control and subtle range of the Continuum fingerboard).

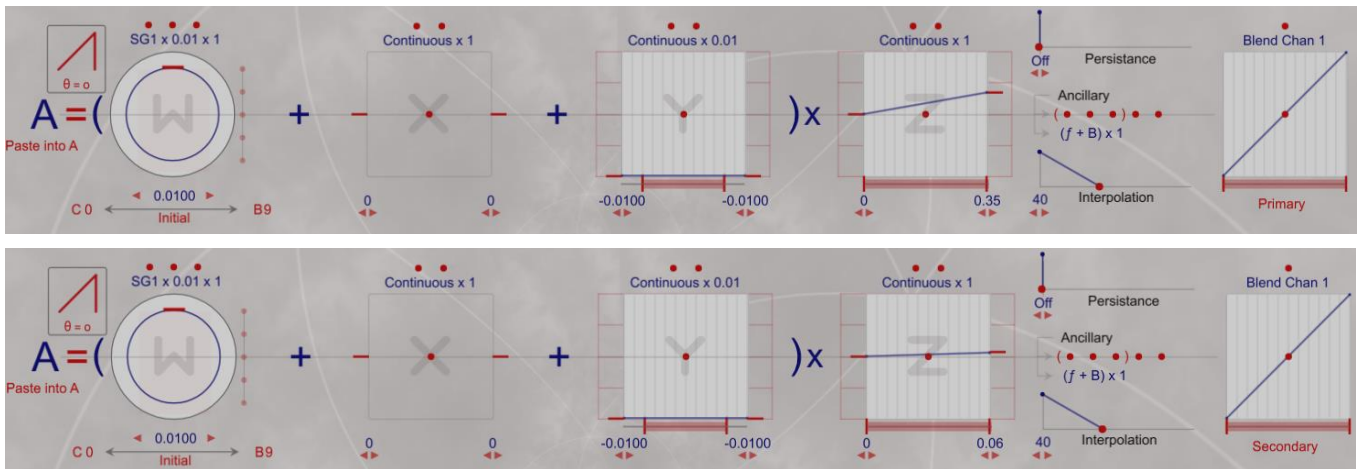

## 7.10. The Touch Area

Using the Haken Editor, a movable area on the continuum fingerboard can be defined and programmed so that when pressed it can control various W, X, Y and Z based functions of a preset. When starting with an Empty preset, the Touch Area is off (default) and noted as a little red "T" at the left of the editor display. It has no effect in this position.



The Touch area can be dragged into any section of the fingerboard and will be outlined. Its size is fixed.

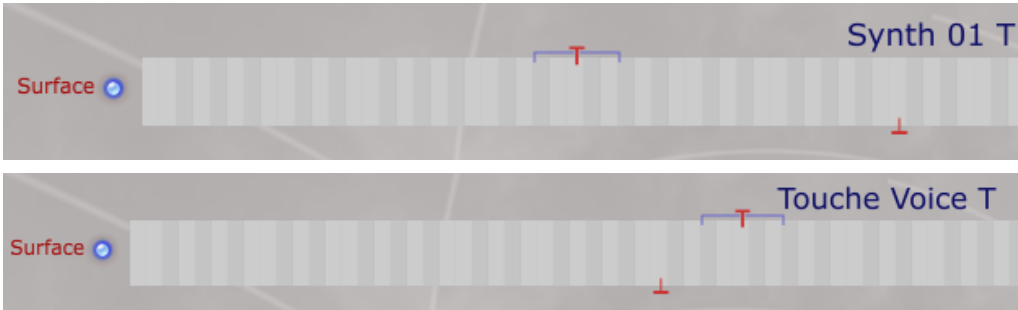

If dragged into a position on the fingerboard and not programmed into the EaganMatrix, the Touch Area will produce no sound if pressed. Note that the Editor's Display Formula function must be set to "Value Display Off" for the Touch Area to respond as expected.

The action that occurs when the Touch Area is pressed is defined in a preset on a formula using the Ancillary "Use Touch Area (or All Fingers Averaged)" option:

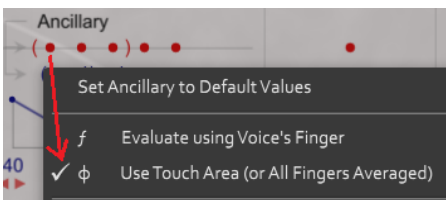

If selected for a formula, the Touch Area can be evaluated based on the W, Z, Y and or Z components of the formula if set to "X 1". In the example below, Formula A is set to be controlled by the Touch Area alone and the Z component is set. Note the older "T" symbol for the Touch Area in the Ancillary formula has been replaced with the lower case Greek letter Phi ( $\phi$ ).

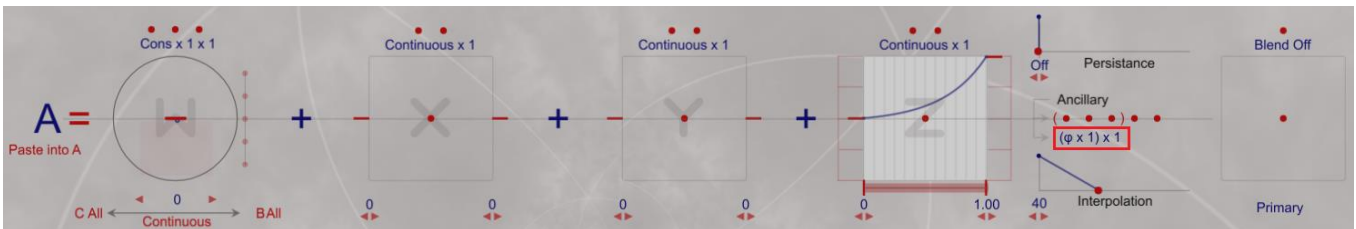

If this is applied to the Spectral Balance of an OSC and the Touch Area has been dragged to a place on the fingerboard, a sine tone will be played when the Touch Area is not pressed as the value of the Touch Area is zero when not pressed. When the Touch Area is pressed, the OSC spectral Balance (harmonic complexity) will increase as pressure increases in the Touch area as only the Z component is affected in formula A.

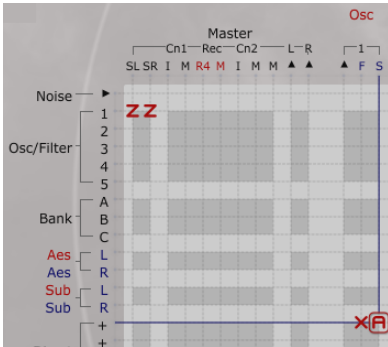

Note that more than one value of the formula is affected by the Touch area is programmed. If Formula A is changed to use the sum of Y and Z to affect Spectral Balance in the Touch area, the harmonic complexity will increase as both Y and Z moved from bottom to top and as Z is pressed deeper into the fingerboard.

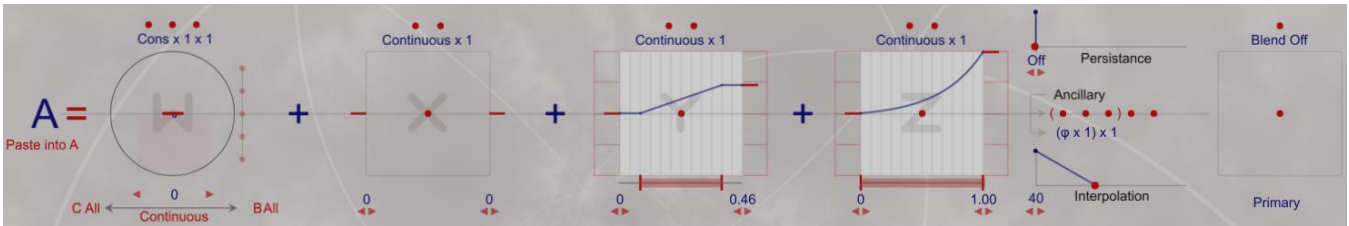

Note that Y when released in the Touch Area will retain its last value and not return to zero automatically as Z will when released. In this case if you leave the Touch Area at top of Y and then play without pressing the touch area, the Spectral balance will not be zero but will be whatever the last Y position was. This often is not the desired operation. The way to overcome this is to multiply the formula by 1 (W) using a gate. This will guarantee Y is not retained when released as it will be zeroed out when the W gate is off.



The Touch area can be applied to more than one formula in a preset and also can be used and applied with an Auxiliary formula. Another common use of the Touch Area is to use it in a formula that controls volume so that no sound is heard until the Touch Area is pressed and the player can concentrate on pitch with one hand and volume/expression using the Touch area (similar to the Touche are in the Ondes Martenot). The following formula B is Touch Area based and controls not only the output on SL/SR but also the input into a Summed Delay.

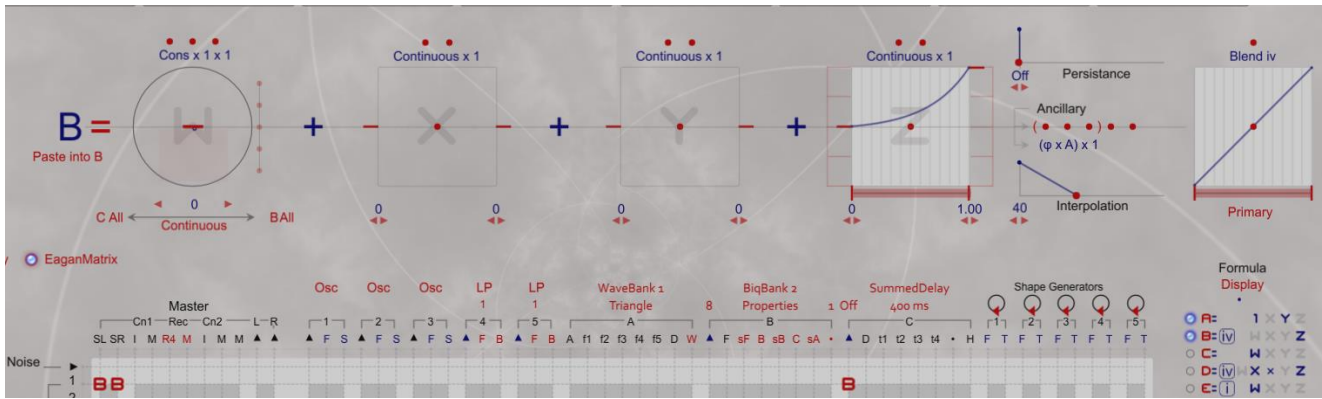

The Touch Area above is defined using an Auxiliary formula A (“Touch x Formula A”), which itself is a blend based on Control “iv”. None of these formulas will kick in unless the Touch Area is pressed.

The Touch Area thus can be used as an additional control if desired in addition to Controls i, ii, iii, iv, v and vi. If you run out of Controls and for example you need to add a vibrato or tremolo, you can use the Touch Area to add an additional control layer to a preset.

## 7.11. Show Formula (Formula Display for Preset Debugging)

When working on presets it is often helpful to know the value or a specific formula or the value of an entire row of formulas. An option above the formula display lets you set a specific formula or column value. This defaults to off, and normally you should keep it off when playing, only using it when you are debugging presets (as it does have an affect on the output in a couple ways if it is set).

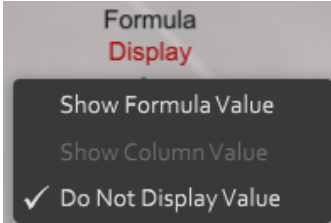

To use the feature, select a formula (crosshairs will tag formula) in the matrix and then select either “Show Formula Value” to view the current value of the formula or “Shown Column Value” to display the value of the entire column you are selected on.

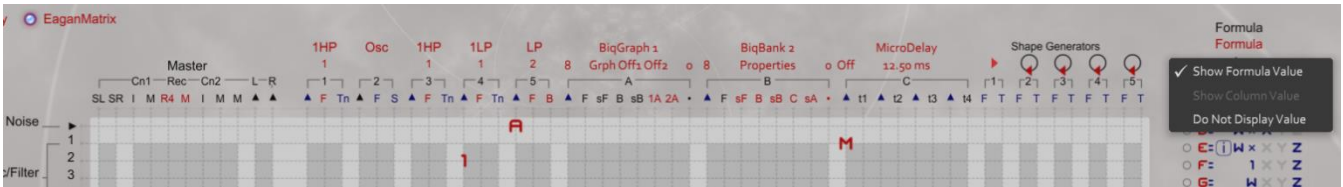

Select a formula for which you want to see current values when you play. Then play the fingerboard and the current value of your selection will be displayed underneath the “Formula” label.

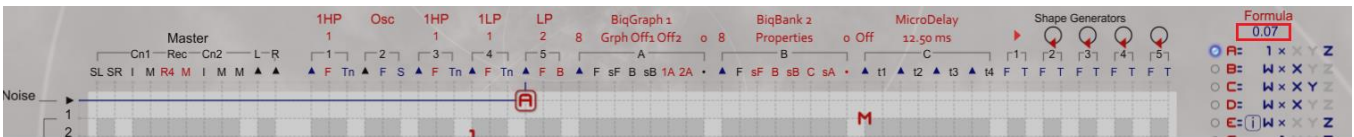

Formulas are not displayed if you are playing the Continuum or ContinuuMini through Midi. You must press the fingerboard.

Note that when Formula Display is on, The Touch area will not be active. Also when on, only DSP1 processing will be used for certain operations like Voice Number (“VNum”) processing. The maximum number of internal synth (not Midi) voices generated will be 8 if formula display is on as expanded polyphony is not considered (DSP1 can process up to 8 voices). For this reason, always turn Formula Display off for performance. Also note firmware versions 9.0 and earlier used a different formula display screen placement.

## 8. Sound Design with the EganMatrix

In order to create an original EganMatrix sound design, start with one of the following options:

- New (create an empty matrix): select Empty Matrix in the Internal Sound Popup Menu.
- Modify (existing preset sound): select one of the other EganMatrix preset sounds in the EganMatrix section of the Internal Sound Popup Menu or open a Preset file from your Mac or PC. Preset files are available in the Archives folder within your Continuum Editor folder, or anywhere else you have previously saved Preset files. For those who are new to the EganMatrix, the Utilities System Preset category has numerous (and often simple) examples of EganMatrix physical modelling functions. Also most System Presets have a Description in the lower right-hand corner of the screen that can be grabbed and scrolled. These descriptions give a summary of the preset's construction, control operation and sometimes suggestions for modifications to try. Remember when experimenting with the EganMatrix to turn down the Gain in case you create loud bursts which are possible, especially when experimenting with filter banks and noise.

Select a point in the matrix by clicking on the desired matrix point. When a matrix point is selected, it will be highlighted with a red outline and cross-hairs will appear that easily mark the Source and Destination for that formula.

Remember to save your work often. If you save a preset with formulas that you have removed from the matrix, they will be lost on saving even if they are defined on the right hand side formula list. To retain a formula you have created but are not using in the matrix, place it on a matrix point that is not being used that is not affecting an output and disable it. These formulas will be retained on saving.

### 8.1. Editing the Selected Matrix Point

To set the selected matrix point to a constant between 1 and 9, type the digit. To set the selected matrix point to a two digit constant between .01 and .99, type a decimal point, then two digits. To set the selected matrix point to a three digit constant between 0.001 and 0.999, type a decimal point then three digits. To set the selected matrix point to a four digit constant between 0.0001 and 0.9999, type a decimal point then four digits. Note that a trailing 0 will be applied to three digit constants in the matrix ("0.562" will be displayed as ".5620").

To set the selected matrix point to a user-defined formula A..V, type the letter. The formula will be displayed above the matrix in the control area. To set the matrix point to a predefined formula W, X, Y, or Z, type the letter.





To delete (clear out) the selected matrix point, press Delete.

To unselect the matrix point, press Escape, or select a different point in the matrix.

To disable a formula select it in the matrix and then press the space bar. To reenable press the space bar again.

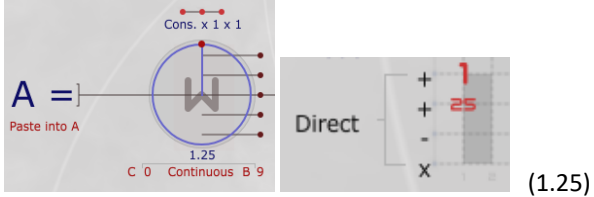
These are all the ways to edit the matrix:

Increase / Decrease Selected Point	Right Arrow / Left Arrow
Edit Selected Matrix Point	Type: a..v for user-defined formulas A..V, w..z for pre-defined formulas W..Z, 1..9 for constant values 1..9, (Note: Constants containing whole and fractional parts are not allowed – 1.25, 3.5, etc. – they must be input as formula constants or built up with multiple Direct + entries if applicable)

	 <p>decimal point then two digits for constants .01 .. .99,</p>  <p>(.01 as displayed in the matrix)</p> <p>decimal point then three digits for constants .001.. .999,          decimal point then four digits for constants .0001.. .9999,</p>  <p>(.001 or .0001 as displayed in matrix until clicked)</p> <p>SHIFT-S or SHIFT-C for row-value-squared or row-value-cubed:</p>  <p>(squared and cubed as displayed in the matrix)</p>
<p>Move Selected Matrix Point</p>	<p>Drag to a new matrix location (Alt-Drag to copy)</p>
<p>Delete Formula</p>	<p>Press Delete to remove the matrix point (disconnect row from column).</p>
<p>Disable / Enable Formula</p>	<p>Press Space bar to disable formula (will turn gray) in matrix and space bar again to reenable (turns back to red). Disabled formulas are retained when a formula is saved.</p>
<p>Deselect Matrix Point and Show Description/Convolution/Recirculator</p>	<p>Escape, or click on Home symbol at bottom left.</p>
<p>Kenton Mini Controller</p>	<p>Assign the Tweak function to a Kenton Rotary (using the Kenton option in the Cogwheel menu) for convenient changes to the selected point.</p>

## 8.2. Three and Four-digit Constants in the Matrix

Four digit constants will be displayed in a shortened form within the matrix, due to display space constraints. Only the first digit followed by a + will be displayed. For example, “.562” and “.5623” will show “5+”. To see all three or four digits, click on the matrix point. The following example is the constant “.1234”:

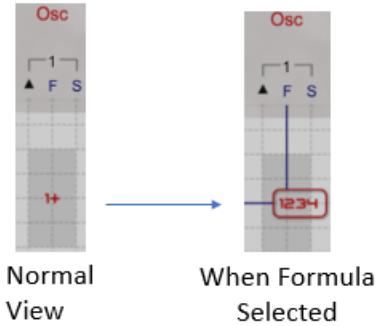

## 8.3. Master Section (Output Section of the EaganMatrix)

The output level from the EaganMatrix of is influenced by a number of controls and programming functions sent into the Master Section.

- Global Attenuation Control (also available through Menu System controlled through rotary)
- Pre (Gain) Level – Applied before Master Section
- Post (Gain) Level – Applied After Master Section (old Gain control)
- Z Based Programmed Level – Or other programmed control such as constant formula
- Input level of L/R unprocessed sub mix components

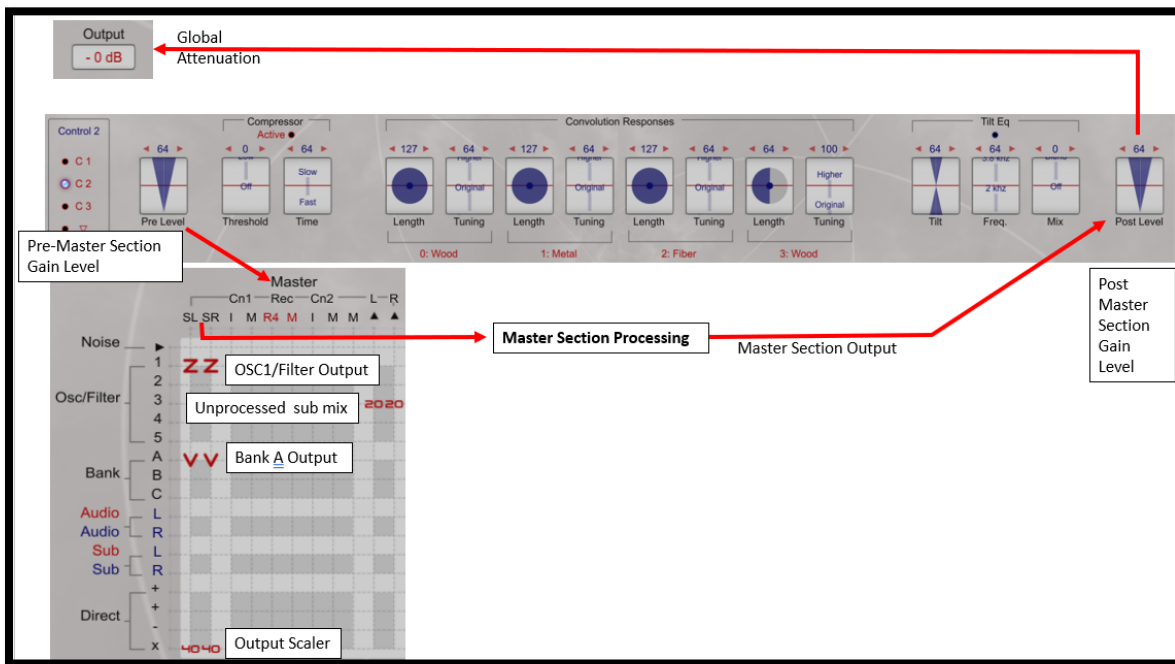

When you output to the SL/SR inputs, Master Section functions are applied, some of which can be programmed in the EaganMatrix.



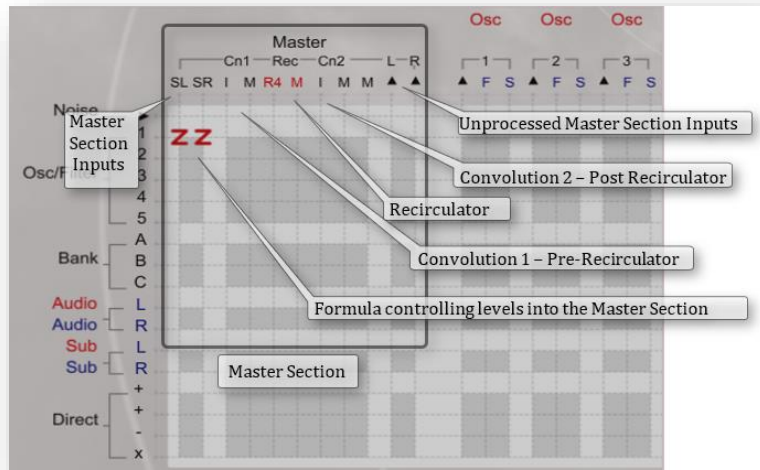

The Pre and Post Gain dials will affect the audio output level in conjunction with the global attenuation setting. The other determining factor on output is the value of formulae in the first two columns of the EaganMatrix where output from the individual EaganMatrix components is sent to the final processing stage. These SL and SR columns are inputs to the Master Section of the EaganMatrix. The Master Section features a built-in limiter and a saturator, a stereo Convolution (Cn1=Pre-recirculator, Cn2=Post-recirculator), Recirculator (reverb and delays), a second (post-Recirculator) Convolution (Cn2), a Tilt EQ and a Compressor.

For saturation and overload effects, use large formula values (typically larger than 1) in the Master SL and SR columns, and use the Gain dial to attenuate the final output level. To have less saturation, select larger values with the Gain dial, and lower values in the SL and SR columns. The Master Section will waveshape high amplitude audio from the SL and SR columns, or soft clip if Via Limiter (see Ancillary Operator Mechanism) is selected in the Master SL and SR formulas. Waveshaping and clipping in the Master Section can be completely avoided by using small formula values (typically less than 1) in the Master SL and SR columns, and increasing the Gain dial to compensate. Also, no waveshaping is done on the Master L and R columns. No loss of accuracy results from scaling values up or down, because the EaganMatrix is based on floating-point computations. Increased saturation will occur with more notes sounding at the same time, since the Master Section works on the stereo sum of all the voices.

The Master Section produces a stereo submix as follows:

Stereo sum (SL, SR) from all voices → Pre-Level → Compressor → Saturation Waveshaper → DC Filter → Pre-Recirculator Convolution → Recirculator → Post-Recirculator Convolution → Submix → Final Mix (add in L/R from all voices to submix) → Tilt EQ → Post Level → Attenuation

[Note: Attenuation is not part of preset data]

The Master's submix is fed back into the matrix on the Sub L and Sub R matrix rows, for optional further processing.

The Master's final mix is controlled by the Master's rightmost M column. For the final mix, the submix is mixed with the sum of L and R from all voices. This final mix is scaled by the Gain dial and sent to the Continuum.

A summary control flow of the Master Section appears below:

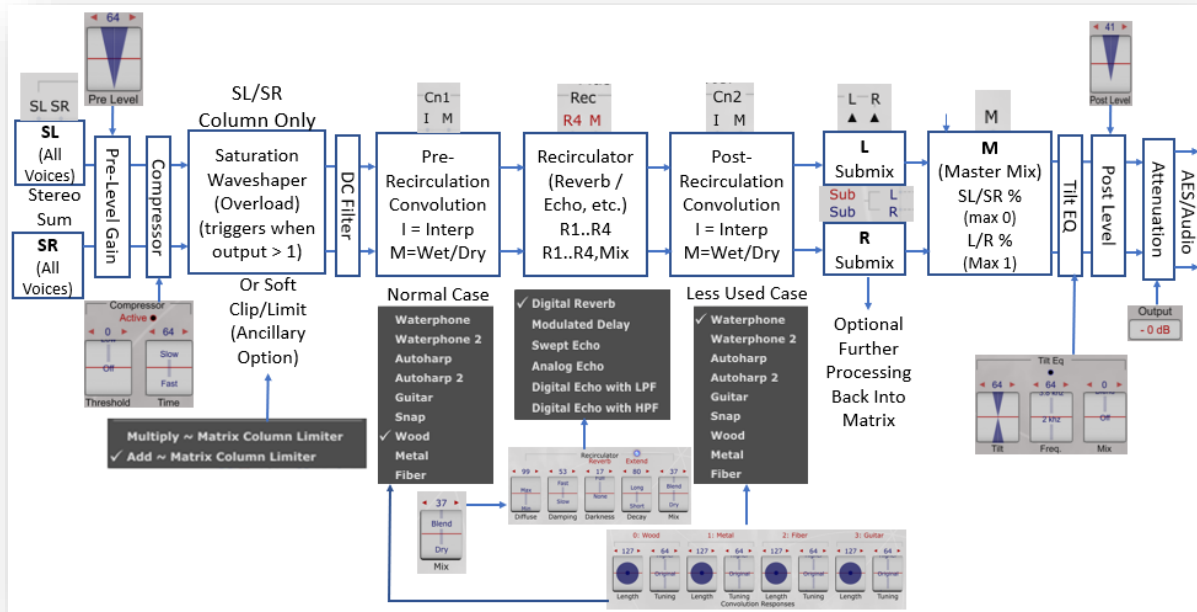

Output – Master Section Control Flow

### 8.3.1 Recirculator Controls and Matrix Offset Programming

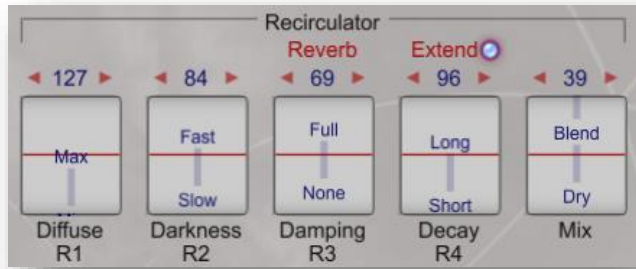

The two selectable Recirculator (“Rec”) control columns in the Matrix are used to add offsets to the Recirculator controls available in Control Panel 1.

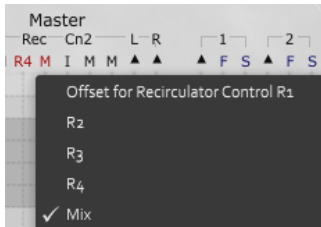

Each of the two columns can be assigned to one of the four possible Recirculator controls (R1..R4) to program offsets from the current setting through the matrix. The second column can also be set to control the Recirculator Mix (M). Set the Recirculator controls (discussed below) to zero if you want full control through the Matrix.

The Recirculator controls can be set to one of six reverb types using the red text selection under “Recirculator”. There are five controls, the first four of which can have different functions based on the reverb type selected. The last controls the Mix of the Recirculator. These are noted below

- **Reverb (Digital Reverb)**
  - R1 = Diffuse - Diffuse is pretty subtle, it interacts with decay time in a way. Depending on decay time, different diffuse times can make the decay sound smoother or if wanted more metallic (ringing). Subtle effect. It helps to fine tune the reverb sound to try to get maximum quality out of the limited RAM resources available to the Recirculator.
  - R2 = Damping - Reduces high frequency content with each feedback loop in the Recirculator. Sound is duller over time.
  - R3 = Darkness - Applies a high frequency roll off to the input into the Recirculator. Sound is duller immediately.
  - R4 = Decay- Amount of Decay/Reverb
- **ModDelay (Modulated Delay)**
  - R1 = ModDepth - Depth and Rate controls are kept to a minimum to avoid feedback issues within the algorithm. It can sound really nice now, creating a very sooth reverb like sound, at the expense of obvious early reflections and a pitch tail in the echoes that sweeps a bit.
  - R2 = ModRate – Rate of Delay
  - R3 = Feedback - Amount of Delay Feedback
  - R4 = Time – Delay Time
- **Analog Echo**
  - R1 = ModDepth
  - R2 = ModRate
  - R3 = Feedback
  - R4 = Time
- **Swept Echo**
  - R1 = Noise - The noise is being added into the recirculating data.
  - R2 = Offset - A reverb timing offset between left and right channel (left channel time is same as left channel time if offset is 0 but is less when offset is increased; this effect is not a linear time scale but can be noticeable/useful in some situations).
  - R3 = Feedback
  - R4 = Time
- **Digital Echo with Low Pass Filter (LPF)**
  - R1 = LPF - When LPF is set to zero it is similar to full damping and when HPF is set to max it's like full damping. The LPF and HPF are applied at the very end, not internal to the recirculating structure. So the echo is echoing the unfiltered signal internally, and then only filtering the output of the echo.
  - R2 = Offset (See above)
  - R3 = Feedback
  - R4 = Time
- **Digital Echo with High Pass Filter (HPF)**

- R1 = HPF - When LPF is set to zero it is similar to full damping and when HPF is set to max it's like full damping. The LPF and HPF are applied at the very end, not internal to the recirculating structure. So the echo is echoing the unfiltered signal internally, and then only filtering the output of the echo.
- R2 = Offset (See above)
- R3 = Feedback
- R4 = Time

Here's one of many examples of Recirculator programming through the matrix. The "Living Pad" preset uses the Analog Echo option with Extend (see below). A continuous Shape Generator on Formula N set to the Sine pattern imposes an organic element to sound by applying a small oscillation ( $W = 0.015$ ) to the R2 "Offset" Control affecting the timing between left and right channels as described above.

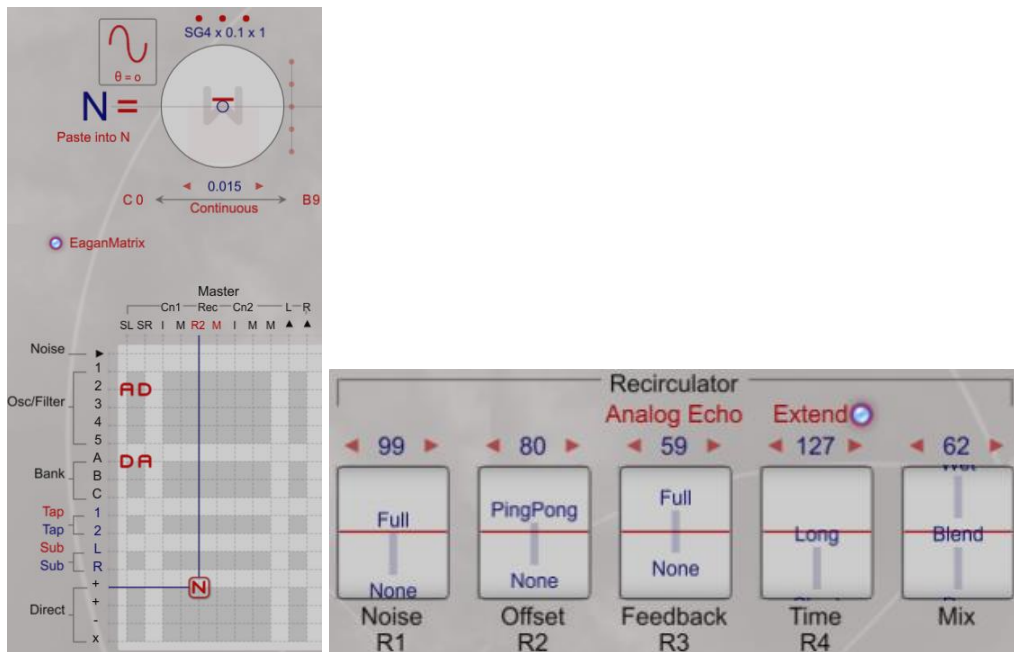

### 8.3.2 Recirculator Extend

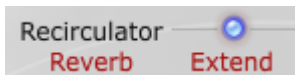

The "Extend" control runs the filter at a lower sample rate – can double the effective max delay time. This means the "wet" part of the signal contains only lower frequencies (below the half sample rate), and you have to mix in "dry" to get more highs. In many cases, this sounds pretty natural -- there are many reverb effects which don't do much with highs and work well with "extend".

### 8.3.3 Convolution Controls

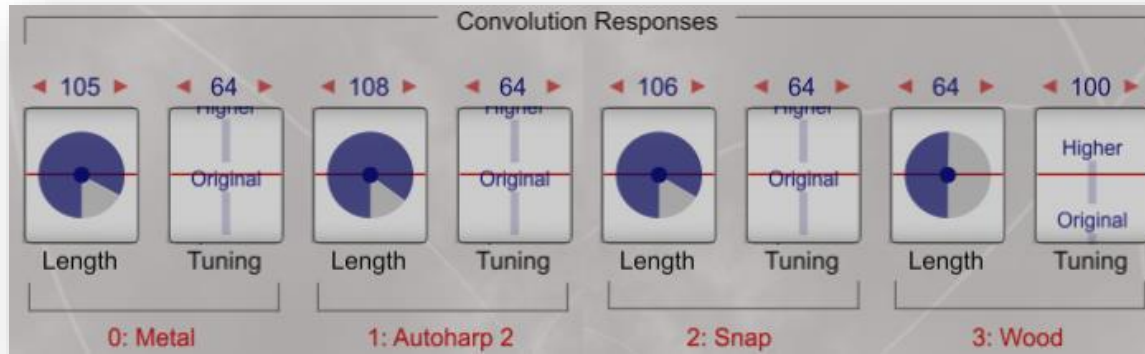

The Convolution body controls can be found in Control Panel 2. Two sets of matrix (I,M) columns affect the Convolution settings, the first pre-Recirculator and the second post-Recirculator. These have no affect if not programmed in the matrix through the Interpolation (I) column which determines what Convolution setting is currently applied and the Mix (M) column (which determines the Dry/Wet ratio). Convolution has no affect if Mix is set to zero (100% dry). If the Interpolation value is set  $< 0$  it will default to 0 and if it is set  $> 3.0$  it will default to 3.0.

Convolutions can be used pre or post Recirculator. When applied before the Recirculator, you can think of them as a coloration (and maybe a sense of space. They are stereo Convolutions that correspond to various materials an acoustic instrument might be made of. When they are applied after the Recirculator, they might correspond to material the walls of a room might be made of.

The Convolutions are normally 128 samples long, but you have control (Length) over this and can make them shorter. Sometimes a shorter Convolution is better because it blurs the sound less; sometimes also it has less low end if you make it shorter. Mostly people experiment through trial and error.

It is helpful to think of the Convolution source material as a brief piece of audio that the Continuum sound passes through. Every sample of the Continuum passes through every sample of the Convolution sequentially, so it creates all sorts of changes to harmonic content and tends to smear the audio across time. It's like a string going through a guitar body. Each Convolution setting has a Length and Tuning parameter that must be set in the Convolution Responses controls.

Changing the Length parameter will progressively truncate the end samples of the Convolution source, from 128 (all samples) to 1. If less "smear" is desired, reduce the length of the Convolution. But you can hear that it effects the sound in a sort of non-predictable way, since the sample itself is non-linear in values. Another way to reduce the smear effect is to try a mix value less than 1.

Changing the tune parameter changes the "pitch" of the Convolution, values  $< 64$  lower the pitch and values  $> 64$  raise it. Generally, it will sound brighter above 64 and duller below 64. This tune parameter is great to "tune" a Preset so it sounds good in a particular key. All Convolution samples have resonance points at various places. You can tune a Convolution so a particular note has its root or a particular harmonic higher.

Four sets of Convolution responses can be set each associated with a range programmed in the matrix. The total Convolution range is 0.0 to 3.0. Each setting can be set to one of the following Convolution options.

- Waterphone
- Waterphone 2
- Autoharp
- Autoharp 2

- Guitar
- Snap
- Wood
- Metal
- Fiber

Frequently, each of the four settings will be different allowing you to program through the full range. If the Interpolation is fractional, a Convolution interpolation will be created where the value falls in the range.

One of the most common techniques for allowing full range interpolation is to create a formula with a max W Range of 3.0 assigned to a Control (often labelled "Body"). The user can then use the control to move through the full range of Convolution responses. This range can be limited to less than 3.0 if a limited set of convolutions is desired. Frequently a preset is designed so that it only moves within the interpolation range of two Convolution settings (0.0 to 1.0). The following extract uses Control "ii" in formula V assigned with the max range of 0.0-3.0 which is used to control the Convolution "Body" setting. Note use of custom text strings "Conv-3", "Conv-4" in the "Body" Control allow the performer to see exactly where the Convolution interpolation is set.

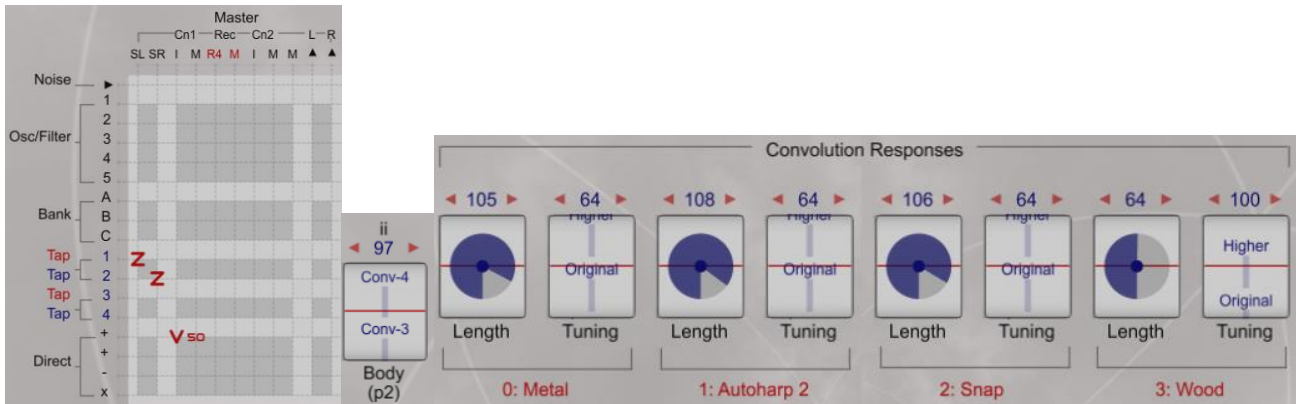

At times, a static/fixed Convolution setting is preferred using a constant as the interpolation value. This can be seen in the "Remembrance Bells" preset:

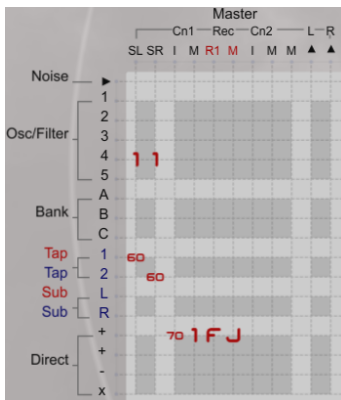

While Convolution is often manipulated with Controls, another technique is to control it with a shape generator for dynamic change of the body. In "Notch Lightening" a continuous SG is used to move through the 0.0-1.0 range of post-Recirculator Convolution using a triangle shape:

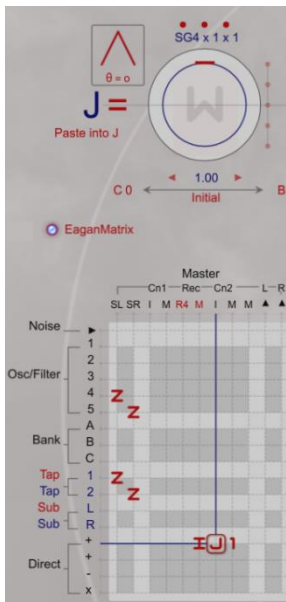

Finally, while not commonly used, some presets use both pre and post Recirculator Convolution, such as “Exposure Ensemble”:

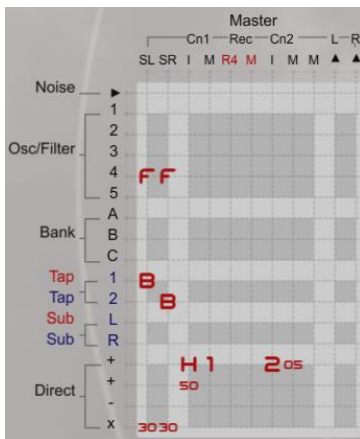

## 8.4. “Reduce Gain” Message

### Reduce Gain

If Overload Protect is active, extreme output levels will be suppressed and the Editor will display a message to “Reduce Gain”. This detection and suppression is only done while the Editor is running, and only when the Overload Protect indicator is lit. The Overload Protect indicator is to the left of the Gain control. Click on the indicator to change its state.

## 8.5. “Reduce Polyphony” Message

### Reduce Polyphony

While the Continuum Editor is running, excessive polyphony values (resulting in excessive computations) will display a message to “Reduce Polyphony”. This automatic detection may not catch borderline situations. If you notice sluggish

behavior - such as sluggish response to pedal changes as you play - try reducing the polyphony by 1 or try simplifying your design.

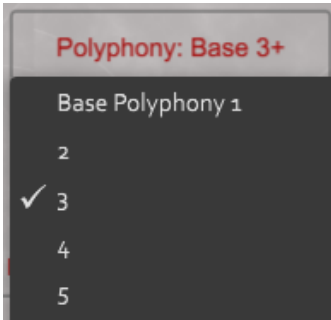

Note that with the “Slim” Continuum or 6x Half-Size or Full-Size models, presets using expanded polyphony allocate 6x the DSP resources than a 1x Continuum. Many presets that were set as 4+ polyphony will thus use 24 DSP processing. If you start adding things to existing presets with a 6x model set to 4+ Polyphony or greater you may see “Reduce Polyphony” messages. Most presets will not require this kind of processing power so if you load a 4+ preset and see “Reduce Polyphony” there is normally no loss of sound or polyphonic usage (in normal playing conditions) if you lower Polyphony to 3+ or in some cases even 2+.

## 8.6. Save your Work

---

Your EaganMatrix designs can be saved to Preset files and opened at a later time (see the Open and Save topic in the Continuum User Guide). When you save your Preset, you will have the opportunity to name it. Save your work often and remember to back up your computer’s file system.

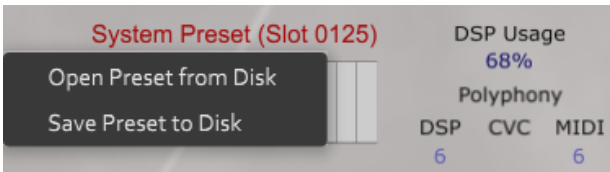



## 9. Need more information?

Feel free to contact Haken Audio with any questions concerning the EaganMatrix.

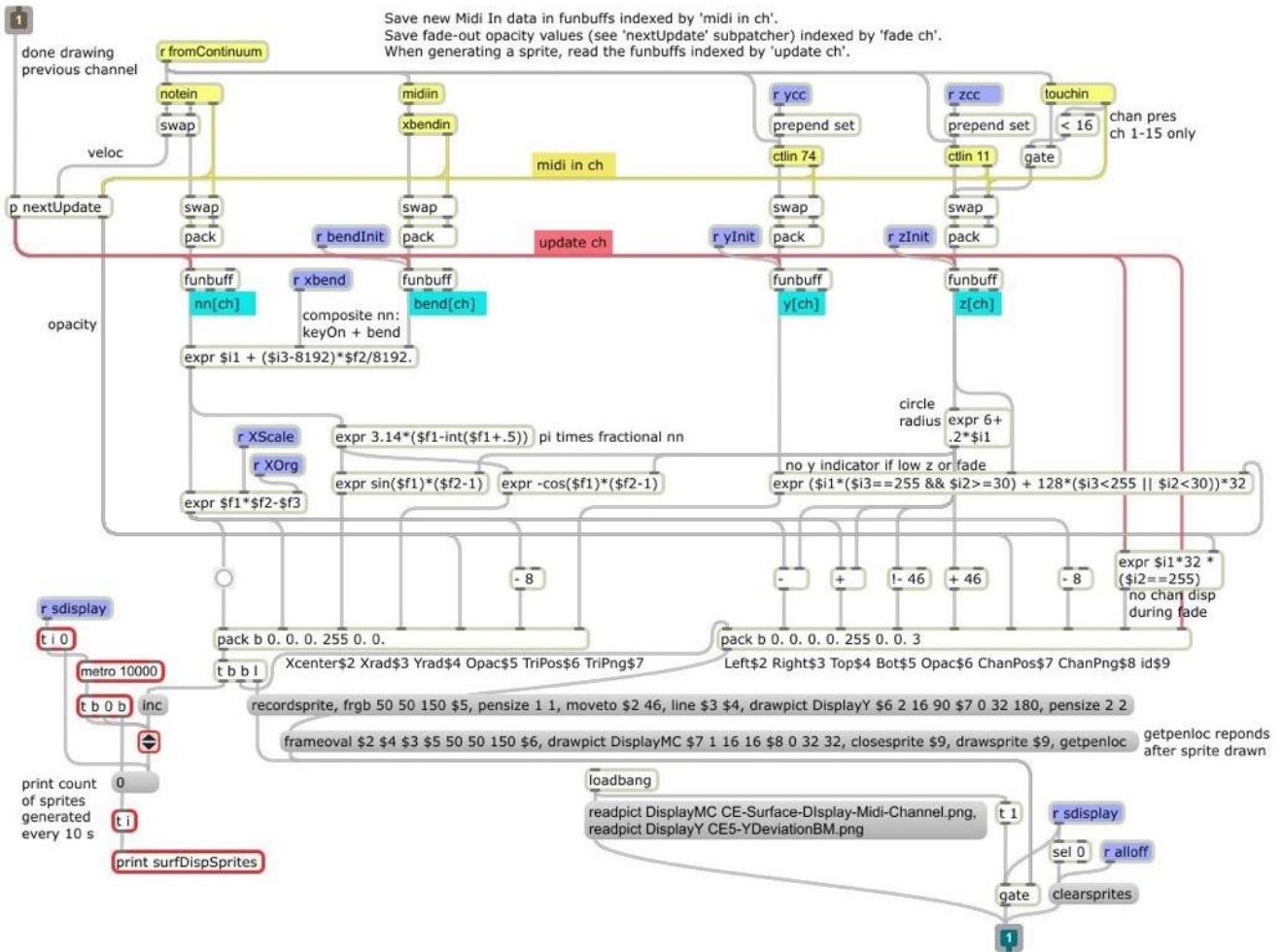

Part of Continuum Editor program, written in Cycling74 Max.