



# 2021 FENDER PROFILES





**THE N. 1 CHOICE**  
OF BOAT BUILDERS  
IN 140 COUNTRIES

**bino**

**bumper**

**RADIAL®**

**sphæra®**

**binox**

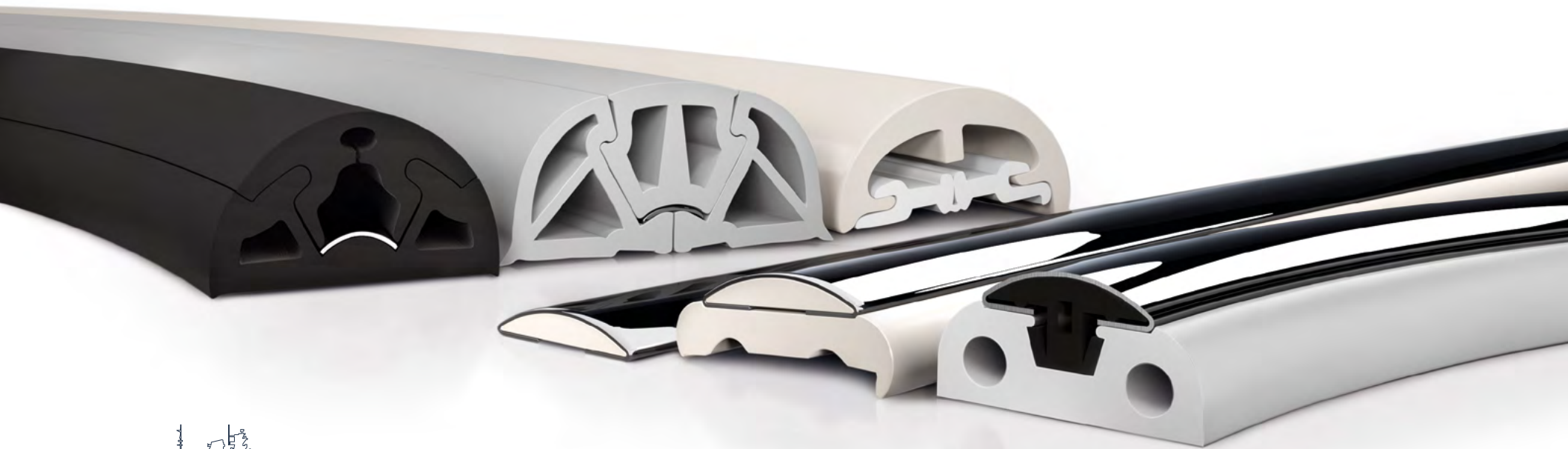

**TESSILMARE®**

# binox

engineered by Rezzonico Ranieri  
made by Tessilmare



THE FIRST STAINLESS STEEL FENDER PROFILE  
**WITHOUT SCREWS**



IL PRIMO PROFILO PARABORDO  
**SENZA VITI**



Binox stainless steel fender profile is fitted without the use of unsightly screws. This product and its unique installation are set to change the way that many sailors and shipbuilders use marine fender profiles. Binox by Tessilmare turns a necessary product into a functional and attractive accessory for any boat, big or small.

Binox si installa senza l'uso di viti. Questo prodotto e la sua tecnologia sono pensati per trasformare radicalmente il concetto di profilo parabordo nel campo nautico. Binox by Tessilmare trasforma un prodotto indispensabile per ogni tipo di imbarcazione in un accessorio funzionale ed estetico.



**TESSILMARE**



Princess Yachts



## UNLIMITED INNOVATION

Binox can be installed like our PVC fender profiles: cold fitted and in a very short time. It's light like a pvc fender profile but strong like a s/s fender profile. And no more rust.

Binox si installa come i nostri profili in pvc: a freddo e in pochissimo tempo. È leggero come un profilo in pvc ma resistente come un profilo in acciaio. E niente più ruggine.



Sanlorenzo

**VERY QUICK**  
INSTALLATION

**HIGH**  
RESISTANCE

**UNMATCHED**  
RESULT

## THE FIRST. BEYOND IMAGINATION

Binox fender profile is set to revolutionize the fender profile industry around the world. There are no holes in the stainless-steel bar. It is pressure fitted into the PVC base for a seamless and attractive finish.

Binox è progettato per rivoluzionare l'industria dei profili parabordo in tutto il mondo. La barra in acciaio si inserisce a pressione nella base in Pvc: il risultato è un profilo privo di viti per una finitura senza precedenti.

Absolute Yachts



Fit the PVC base onto the boat.  
Fissate la base in PVC sullo scafo.

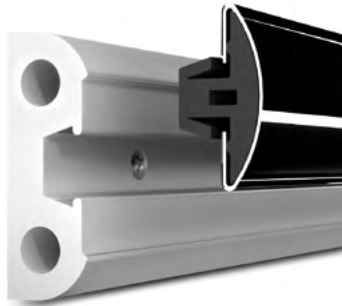

The 3 m S/S bar can be pressure fitted.  
La barra in acciaio si installa a pressione.

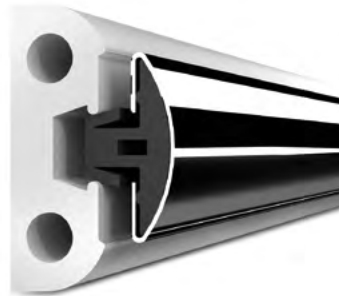

A result never seen before.  
Il risultato è senza precedenti.

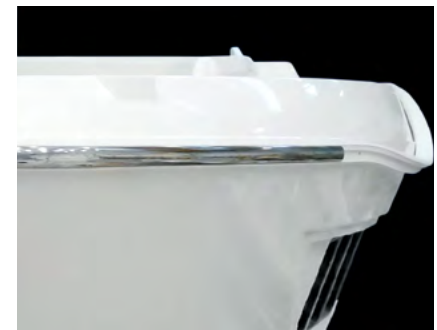

What was once the exclusive domain of luxury mega yachts, Binox is now available for boats of all sizes.

**4** Pensato per soddisfare l'esclusivo mercato dei mega yacht, Binox è ora disponibile per differenti tipi di imbarcazione.

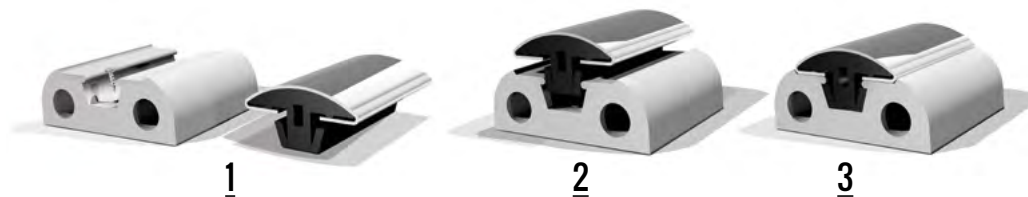

## HOW TO BEND

[www.youtube.com/tessilmare](http://www.youtube.com/tessilmare)

1



### PVC BASE INSTALLATION

Attach the soft profile of the base against the entire length of the boat with screws. The screw head has to be flush with the PVC, without protrusions.

### APPLICAZIONE DELLA BASE IN PVC

La base PVC va avvitata all'imbarcazione seguendo tutto il perimetro. La testa delle viti dovrà essere a filo del pvc senza sporgenze.

2



### S/S BAR INSTALLATION

The stainless steel bars are pressure fitted, the operation will be faster using a small piece of PVC base and a hammer.

### APPLICAZIONE DELLA BARRA INOX

Le barre in acciaio si applicano a pressione manualmente, l'operazione sarà più veloce utilizzando una porzione di base in pvc ed un martello.

3



### JOINT CAP INSTALLATION

A joint cap is required in between each 3 meter bar.

### APPLICAZIONE DEL COPRIGIUNTA

Tra una barra di 3 metri e l'altra è indispensabile applicare il coprigiunta.

4



### CUTTING S/S AND PVC BASE AND END CAP INSTALLATION

Cut any loose PVC parts with a box cutter. As a final step, install the end-caps.

### TAGLIO DELLE PARTI INOX E PVC IN ECCEDEZZA E FINITURE

Tagliare eventuali parti in PVC in eccedenza con semplice taglierino. A lavoro ultimato rifinire con i terminali di finitura.

5

# FEATURES

FINISH   
stainless steel

## BAR [ S/S + PVC ]



description descrizione	item articolo	weight peso	sizes misure	packaging imballo	min. order ordine min.
S/S Bar Binox 25 Barra in acciaio Binox 25	<b>130-230-125</b>	18 oz/yd 522 g/m	1" x 9.8 ft 3 m	tube tubo	78' 24 m
S/S Bar Binox 35 Barra in acciaio Binox 35	<b>130-230-135</b>	27 oz/yd 770 g/m	1-3/8" x 9.8 ft 3 m	tube tubo	78' 24 m
S/S Bar Binox 50 Barra in acciaio Binox 50	<b>130-230-150</b>	50 oz/yd 1.410 g/m	2" x 9.8 ft 3 m	tube tubo	78' 24 m
S/S Bar Binox 65 Barra in acciaio Binox 65	<b>130-230-165</b>	58 oz/yd 1.632 g/m	2"-9/16" x 9.8 ft 3 m	tube tubo	78' 24 m

COLORS   
black RAL 9004    grey RAL 7047    white RAL 9010

## BASE with lip [ PVC ]

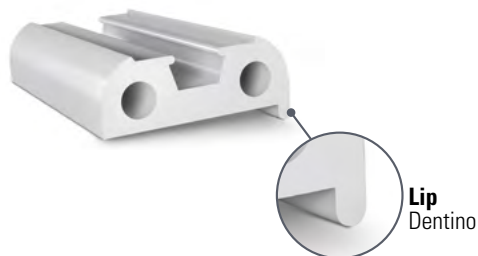

## BASE [ PVC ]



description descrizione	type tipo	item articolo	colors ● ● ●	weight peso	sizes misure	packaging imballo
PVC base - Binox 25	with lip con dentino	<b>130-230-040-L</b>	-B -G -W	19 oz/yd 533 g/m	1"-9/16" 40 mm	coil rotolo
PVC base - Binox 25		<b>130-230-040</b>	-B -G -W	18 oz/yd 510 g/m	1"-9/16" 40 mm	coil rotolo
PVC base - Binox 35	with lip con dentino	<b>130-230-050-L</b>	-B -G -W	33 oz/yd 945 g/m	2" 50 mm	coil rotolo
PVC base - Binox 35		<b>130-230-050</b>	-B -G -W	33 oz/yd 925 g/m	2" 50 mm	coil rotolo
PVC base - Binox 50	with lip con dentino	<b>130-230-070-L</b>	-B -G -W	63 oz/yd 1.800 g/m	2-3/4" 70 mm	coil rotolo
PVC base - Binox 50		<b>130-230-070</b>	-B -G -W	63 oz/yd 1.780 g/m	2-3/4" 70 mm	coil rotolo
PVC base - Binox 65	with lip con dentino	<b>130-230-090-L</b>	-B -G -W	72 oz/yd 2.052 g/m	3-9/16" 90 mm	coil rotolo
PVC base - Binox 65		<b>130-230-090</b>	-B -G -W	71 oz/yd 2.003 g/m	3-9/16" 90 mm	coil rotolo

FINISH  
stainless steel



**END CAP [ S/S ]**

description descrizione	item articolo	unit unità
S/S End Cap - Binox 25 Terminale inox - Binox 25	130-500-425	kit
S/S End Cap - Binox 35 Terminale inox - Binox 35	130-500-435	kit
S/S End Cap - Binox 50 Terminale inox - Binox 50	130-500-450	kit
S/S End Cap - Binox 65 Terminale inox - Binox 65	130-500-465	kit

**JOINT CAP [ S/S ]**



description descrizione	item articolo	unit unità
S/S Joint Cap - Binox 25 Coprigiunta inox - Binox 25	130-500-125	1 piece each bar necessary 1 pezzo per barra
S/S Joint Cap - Binox 35 Coprigiunta inox - Binox 35	130-500-135	1 piece each bar necessary 1 pezzo per barra
S/S Joint Cap - Binox 50 Coprigiunta inox - Binox 50	130-500-150	1 piece each bar necessary 1 pezzo per barra
S/S Joint Cap - Binox 65 Coprigiunta inox - Binox 65	130-500-165	1 piece each bar necessary 1 pezzo per barra

## JOINT & END CAP

S/S bars give a result never seen before. We suggest the use of our S/S joint caps and end caps for a better technical and aesthetic effect.

Le barre in acciaio danno un risultato senza precedenti. Sugeriamo l'uso di coprigiunta e terminali in acciaio per un miglior risultato tecnico ed estetico.







AL FALASI MARINE



GULF CRAFT



SANLORENZO



ABSOLUTE YACHTS

 **BINOX by Tessilmare**



BRAVADA YACHTS



PRINCESS YACHTS





Fairline Yachts

Sphæra is the first fender profile which combines higher technical performance with better quality and design compared to other traditional systems.

Sphæra è il primo profilo parabordo che associa elevate prestazioni tecniche a finiture di pregio, collocandosi su un piano nettamente superiore rispetto ai tradizionali sistemi in uso.

sphæra®

engineered by Rezzonico Ranieri  
made by Tessilmare

**A VERY INNOVATIVE  
FENDER PROFILE**



**IL PIÙ INNOVATIVO  
DEI PROFILI PARABORDO**





Hellwig

## JOINT & END CAP

The joint caps keep the bars perfectly aligned, thereby avoiding multiple and unnecessary drilling without altering the pitch.

Il coprigiunta mantiene saldamente allineate le barre evitandone la foratura delle estremità e lasciando allo stesso tempo inalterata la sequenza delle viti.

## EASILY ADAPTABLE

We have created a specific stainless steel profile with a Duralene® core which guarantees its adaptability to the hull. Its patented process prevents deformation and allows bending on difficult angles with a minimal effort.

Il riempimento in Duralene® caratterizza l'elevata adattabilità del profilo in acciaio alle geometrie dello scafo, evitando deformazioni delle curve e onerose operazioni di curvatura.

The pvc base is supplied in reels of the required length. That avoids any aesthetical problems of bar junctions of some traditional systems.

La base in pvc fornita in rotoli a misura della imbarcazione risolve i problemi estetici di giunzione delle barre in pvc rigido di alcuni sistemi tradizionali.

Ranieri International



Sessa Marine

10



**ULTRA LIGHT**

**ULTRA STRONG**

**EASILY BENDABLE**

## INSTALLATION OPTIONS



Stainless steel bar  
Barra in acciaio



DIRECTLY FITTED

Stainless steel bar + slim base  
Barra in acciaio + base slim



WITH A PVC SLIM BASE

Stainless steel bar + pvc base  
Barra in acciaio + base pvc



WITH A PVC STRONG BASE



TESSILMARE

**Reduce by 70%** your stock and expenses

- 316 L stainless steel
- Exceptionally strong
- Lightweight
- Easy to bend and install
- Crashproof
- Competitive price
- Reduced waste
- Precious aesthetical look
- Easy to repair and refit
- Acciaio inox 316 L
- Altissima resistenza agli urti
- Leggero
- Facile da piegare e installare
- Non si deforma
- Prezzo altamente competitivo
- Nessuno spreco di materiale
- Estetica di pregio
- Facile da riparare o sostituire

## FITTING STEPS

1



### PVC BASE INSTALLATION

The PVC base is placed on the boat with paper tape. The base can be cut to the right boat size to avoid any waste or interruption.

### POSIZIONAMENTO DELLA BASE IN PVC

Posizionamento della base con nastro di carta. La base è prodotta della lunghezza specifica dell'imbarcazione, per non avere scarti di posa o interruzioni.

2



### S/S BAR INSTALLATION

Steel bars are pre-drilled and are secured together with the base using steel screws. Bow and stern bends are created directly on the boat, that works as bending template.

We recommend the use of a wood template only in presence of very sharp and difficult boat side bends.

### POSA DEL PROFILO IN ACCIAIO

Le barre di acciaio preforate consentono di avvitare allo scafo, in un unico passaggio, entrambi i profili.

Le curve di prua e di poppa si eseguono direttamente sulla barca, utilizzando la stessa come dima.

Per raggiature acute, curve ai lati dell'imbarcazione o curve particolarmente difficili, si consiglia l'utilizzo di una semplice dima in legno.

12

3



### JOINT AND END CAPS INSTALLATION

Our well-designed and functional joint caps perfectly cover the gaps at junctures and keep the bars perfectly aligned to avoid any aesthetical problem of double screws.

Stainless steel end caps give an elegant finishing touch.

### POSA DEI COPRIGIUNTA E TERMINALI

I pratici ed eleganti coprigiunta risolvono l'allineamento delle barre ed evitano problemi estetici derivanti dalle doppie viti.

L'applicazione del profilo è completata con il montaggio degli eleganti terminali in acciaio.

HOW TO BEND

[www.youtube.com/tessilmare](http://www.youtube.com/tessilmare)

## FEATURES

FINISH  
  
 stainless steel



**BAR [ S/S + PVC ]**

COLORS  
  
 black grey white  
 RAL RAL RAL  
 9004 7047 9010



**STANDARD BASE with lip [ PVC ]**



**Lip**  
Dentino

**NEW 2021**



**STANDARD BASE [ PVC ]**



**TESSILMARE**

description descrizione	item articolo	weight peso	min bending Rad R min curvatura	packaging imballo	min. order ordine min.
Sphæra 25	130-130-125	16 oz/yd 465 g/m	1-1/8" 30 mm	tube tubo	39' 12 m
Sphæra 35	130-130-135	30 oz/yd 860 g/m	2-7/8" 75 mm	tube tubo	39' 12 m
Sphæra 50	130-130-150	42 oz/yd 1.180 g/m	3-7/8" 100 mm	tube tubo	39' 12 m
Sphæra 65	130-130-165	54 oz/yd 1.535 g/m	3-7/8" 100 mm	tube tubo	39' 12 m

description descrizione	type tipo	item articolo	colors ● ● ●	weight peso	min bending Rad R min curvatura	packaging imballo	min. order ordine min.
PVC base - Sphæra 25	with lip con dentino	130-130-040	-B -G -W	13 oz/yd 378 g/m	1-1/8" 30 mm	coil rotolo	39' 12 m
PVC base - Sphæra 25		130-130-041	-B -G -W	12 oz/yd 352 g/m	1-1/8" 30 mm	coil rotolo	118' 36 m
PVC base - Sphæra 35	with lip con dentino	130-130-050	-B -G -W	24 oz/yd 674 g/m	2-7/8" 75 mm	coil rotolo	39' 12 m
PVC base - Sphæra 35		130-130-051	-B -G -W	21 oz/yd 585 g/m	2-7/8" 75 mm	coil rotolo	118' 36 m
PVC base - Sphæra 50	with lip con dentino	130-130-070	-B -G -W	46 oz/yd 1.295 g/m	3-7/8" 100 mm	coil rotolo	39' 12 m
PVC base - Sphæra 50		130-130-071	-B -G -W	44 oz/yd 1.254 g/m	3-7/8" 100 mm	coil rotolo	118' 36 m
PVC base - Sphæra 65	with lip con dentino	130-130-090	-B -G -W	48 oz/yd 1.375 g/m	3-7/8" 100 mm	coil rotolo	39' 12 m
PVC base - Sphæra 65		130-130-091	-B -G -W	47 oz/yd 1.330 g/m	3-7/8" 100 mm	coil rotolo	118' 36 m

# FEATURES

COLORS

		
black	grey	white
RAL 9004	RAL 7047	RAL 9010

**NEW 2021**



**Lip**  
Dentino

**BASE SLIM with lip [ PVC ]**



**BASE SLIM [ PVC ]**

description descrizione	type tipo	item articolo	colors ● ● ●	weight peso	min bending Rad R min curvatura	packaging imballo	min. order ordine min.
SLIM base - Sphæra 25	with lip con dentino	130-130-038	-B -G -W	5 oz/yd 135 g/m	1-1/8" 30 mm	coil rotolo	118' 36 m
SLIM base - Sphæra 25		130-130-039	-B -G -W	4 oz/yd 125 g/m	1-1/8" 30 mm	coil rotolo	39' 12 m
SLIM base - Sphæra 35	with lip con dentino	130-130-048	-B -G -W	5 oz/yd 145 g/m	2-7/8" 75 mm	coil rotolo	118' 36 m
SLIM base - Sphæra 35		130-130-049	-B -G -W	5 oz/yd 135 g/m	2-7/8" 75 mm	coil rotolo	39' 12 m
SLIM base - Sphæra 50	with lip con dentino	130-130-068	-B -G -W	7 oz/yd 205 g/m	3-7/8" 100 mm	coil rotolo	118' 36 m
SLIM base - Sphæra 50		130-130-069	-B -G -W	6 oz/yd 183 g/m	3-7/8" 100 mm	coil rotolo	39' 12 m
SLIM base - Sphæra 65	with lip con dentino	130-130-088	-B -G -W	18 oz/yd 515 g/m	3-7/8" 100 mm	coil rotolo	118' 36 m
SLIM base - Sphæra 65		130-130-089	-B -G -W	15 oz/yd 425 g/m	3-7/8" 100 mm	coil rotolo	39' 12 m



## TOP CAPS [ S/S ]

description descrizione	item articolo	
S/S Joint cap - Sphæra 25 Coprigiunta inox - Sphæra 25	<b>130-500-125</b>	1 piece each bar necessary 1 pezzo per barra
S/S Joint cap - Sphæra 35 Coprigiunta inox - Sphæra 35	<b>130-500-135</b>	1 piece each bar necessary 1 pezzo per barra
S/S Joint cap - Sphæra 50 Coprigiunta inox - Sphæra 50	<b>130-500-150</b>	1 piece each bar necessary 1 pezzo per barra
S/S Joint cap - Sphæra 65 Coprigiunta inox - Sphæra 65	<b>130-500-165</b>	1 piece each bar necessary 1 pezzo per barra



## END CAPS [ S/S ]

description descrizione	item articolo	
S/S End cap - Sphæra 25 Terminale inox - Sphæra 25	<b>130-500-625</b>	mounted without PVC base montato senza base PVC
S/S End cap - Sphæra 35 Terminale inox - Sphæra 35	<b>130-500-635</b>	mounted without PVC base montato senza base PVC
S/S End cap - Sphæra 50 Terminale inox - Sphæra 50	<b>130-500-650</b>	mounted without PVC base montato senza base PVC
S/S End cap - Sphæra 65 Terminale inox - Sphæra 65	<b>130-500-665</b>	mounted without PVC base montato senza base PVC

FINISH   
stainless steel



## END CAP KITS [ S/S ]

description descrizione	item articolo	
S/S End cap KIT - Sphæra 25 KIT Terminall inox - Sphæra 25	<b>130-500-725</b>	mounted with PVC base montato con base PVC
S/S End cap KIT - Sphæra 35 KIT Terminall inox - Sphæra 35	<b>130-500-735</b>	mounted with PVC base montato con base PVC
S/S End cap KIT - Sphæra 50 KIT Terminall inox - Sphæra 50	<b>130-500-750</b>	mounted with PVC base montato con base PVC
S/S End cap KIT - Sphæra 65 KIT Terminall inox - Sphæra 65	<b>130-500-765</b>	mounted with PVC base montato con base PVC





FAIRLINE YACHTS



FERRETTI YACHTS



BAVARIA YACHTS



LEX BOATS

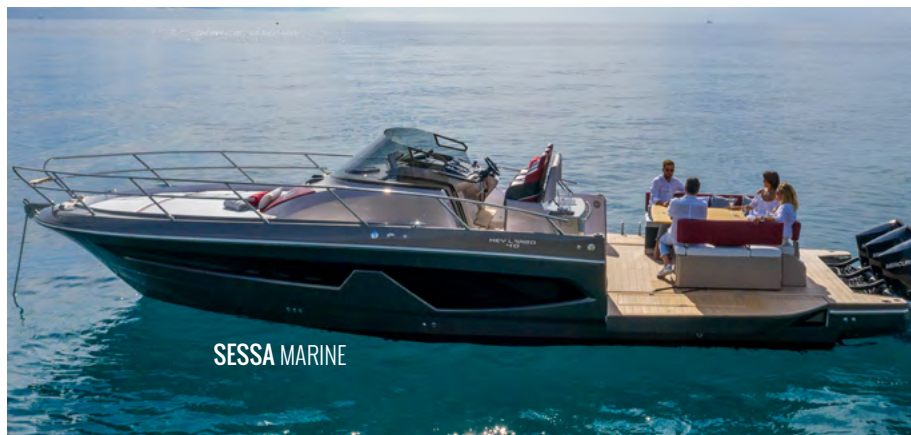

SESSA MARINE



RANIERI INTERNATIONAL

SPHÆRA by Tessilmare



GREENLINE YACHTS



SUPREMA MARINE



HELLWIG





Al Falasi Marine

Fast and easy to install, Radial is the PVC fender profile without rivals. It's different from all other profiles on the market and can be cold fitted in just a few steps. The soft seamless insert is supplied in custom-cut reels to avoid waste.

Radial è il profilo parabordo in pvc senza rivali. A differenza di tutti i profili presenti sul mercato Radial è applicabile a freddo in pochi e veloci passaggi. Fornito in rotoli tagliati su misura per evitare spreco di materiale e interruzioni estetiche.

### TIME AND LABOR SAVINGS



### RISPARMIO SU TUTTI I FRONTI

# RADIAL®

engineered by Rezzonico Massimo  
made by Tessilmare



Sealver



## JOINT & END CAP

Two types of matching joints and end caps: convenient PVC or elegant Stainless Steel giving a finishing touch.

Pratici ed eleganti coprigiunta e terminali sia in PVC che in acciaio completano la finitura dello specchio di poppa e del giro barca.



18

## ADVANTAGES

- Seamless installation
  - Custom cut
  - Easy to repair or refit
  - Quick setup
  - No pre-heating necessary
  - 70% faster to assemble
- 
- Nessuna interruzione
  - Fornito su misura
  - Facile da riparare o sostituire
  - Veloce da installare
  - Si applica a freddo
  - Economico

**COLD FITTING**

**EXTREMELY FLEXIBLE**

**PERFECT HULL ADHESION**

Sargo Boats



Velvette Marine

## HOW TO BEND

[www.youtube.com/tessilmare](http://www.youtube.com/tessilmare)

## FITTING STEPS

1

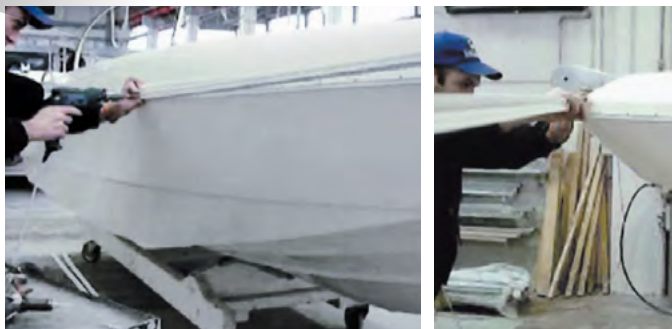

### RIGID TRACK INSTALLATION

Cold screwing or riveting the rigid track with no special tool. The track bends perfectly in all boat directions so installation is quick and easy.

### APPLICAZIONE DELLA BASE RIGIDA

Avvitatura o rivettatura a freddo della base rigida, senza l'ausilio di attrezzature. La base segue perfettamente i tre assi dell'imbarcazione consentendo un'applicazione facile e veloce.

Track can be bent by hand, no need to heat up the profile.  
Piegatura a mano della base rigida, senza necessità di riscaldare.

2

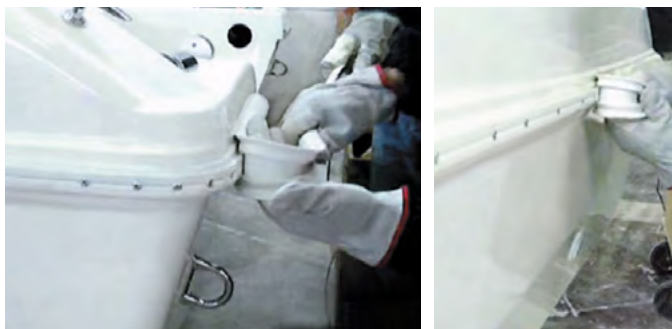

### SOFT PROFILE INSTALLATION

The soft pvc profile is installed cold, no need for any special tool or pre-heating. The track bends perfectly in any direction all around the boat with no waste or unsightly joints.

### APPLICAZIONE DEL PROFILO

Applicazione del profilo in pvc eseguita a freddo, senza necessità di attrezzature od operazioni di pre-riscaldamento. L'alta adattabilità alle curve dello scafo permette di applicare il profilo in pvc lungo tutto il perimetro dell'imbarcazione, senza scarti di lavorazione o antiestetiche giunzioni.

3



### END CAP INSTALLATION

Profile cutting and installation of pvc or stainless steel End and Joint Caps.

### APPLICAZIONE DEL TERMINALE

Taglio del profilo. Completamento del montaggio con gli accessori di finitura, terminali e coprigiunta, disponibili in pvc o nella versione in acciaio.

# FEATURES

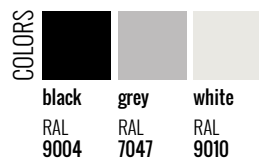

## SOFT PROFILE [ PVC ]



## RIGID TRACK [ DURALENE® ]

description descrizione	item articolo	colors ● ● ●	weight peso	min bending Rad R min curvatura	packaging imballo	confezioni da
rigid track Radial 30 canalina Radial 30	130-141-006		6 oz/yd 165 g/m	2" 50 mm	bundle fasci	78' 24 m
soft profile Radial 30 inserto Radial 30	130-141-007	-B -G -W	13 oz/yd 370 g/m		coil rotolo	78' 24 m
rigid track Radial 40 canalina Radial 40	130-141-011		9 oz/yd 262 g/m	2-3/8" 60 mm	bundle fasci	78' 24 m
soft profile Radial 40 inserto Radial 40	130-141-012	-B -G -W	18 oz/yd 510 g/m		coil rotolo	78' 24 m
rigid track Radial 52 canalina Radial 52	130-141-016		14 oz/yd 410 g/m	2-3/4" 70 mm	bundle fasci	78' 24 m
soft profile Radial 52 inserto Radial 52	130-141-017	-B -G -W	34 oz/yd 960 g/m		coil rotolo	78' 24 m
rigid track Radial 65 canalina Radial 65	130-141-021		15 oz/yd 432 g/m	3-1/8" 80 mm	bundle fasci	78' 24 m
soft profile Radial 65 inserto Radial 65	130-141-022	-B -G -W	43 oz/yd 1.220 g/m		coil rotolo	78' 24 m
rigid track Radial 80 canalina Radial 80	130-141-026		20 oz/yd 565 g/m	3-7/8" 100 mm	bundle fasci	78' 24 m
soft profile Radial 80 inserto Radial 80	130-141-027	-B -G -W	60 oz/yd 1.710 g/m		coil rotolo	78' 24 m
rigid track Radial 100 canalina Radial 100	130-141-031		37 oz/yd 1.050 g/m	6-1/4" 160 mm	bundle fasci	78' 24 m
soft profile Radial 100 inserto Radial 100	130-141-032	-B -G -W	95 oz/yd 2.700 g/m		coil rotolo	78' 24 m

FINISH  
stainless steel



## END CAPS [ S/S ]



description descrizione	item articolo
S/S End cap - Radial 30 Terminale in acciaio - Radial 30	130-500-500
S/S End cap - Radial 40 Terminale in acciaio - Radial 40	130-500-510
S/S End cap - Radial 52 Terminale in acciaio - Radial 52	130-500-520
S/S End cap - Radial 65 Terminale in acciaio - Radial 65	130-500-530
S/S End cap Kit - Radial 80 Kit Terminale in acciaio - Radial 80	130-500-580
S/S End cap Kit - Radial 100 Kit Terminale in acciaio - Radial 100	130-500-600

FINISH  
stainless steel



## TOP CAPS [ S/S ]

description descrizione	item articolo
S/S Top cap - Radial 40 Coprigiunta in acciaio - Radial 40	130-500-610
S/S Top cap - Radial 52 Coprigiunta in acciaio - Radial 52	130-500-620
S/S Top cap - Radial 65 Coprigiunta in acciaio - Radial 65	130-500-630
S/S Top cap - Radial 80 Coprigiunta in acciaio - Radial 80	130-500-640

COLORS  
black RAL 9004  
grey RAL 7047  
white RAL 9010



## END CAPS [ PVC ]



description descrizione	item articolo	colors ● ● ○
PVC End cap - Radial 30 Terminale in PVC - Radial 30	130-500-010	-B -G -W
PVC End cap - Radial 40 Terminale in PVC - Radial 40	130-500-050	-B -G -W
PVC End cap - Radial 52 Terminale in PVC - Radial 52	130-500-030	-B -G -W
PVC End cap - Radial 65 Terminale in PVC - Radial 65	130-500-030	-B -G -W
PVC End cap - Radial 100 Terminale in PVC - Radial 100	130-500-091	-B -G -W

COLORS  
black RAL 9004  
grey RAL 7047  
white RAL 9010



## TOP CAPS [ PVC ]

description descrizione	item articolo	colors ● ● ○
PVC Top cap - Radial 30 Coprigiunta in PVC - Radial 30	130-500-310	-B -G -W
PVC Top cap - Radial 40 Coprigiunta in PVC - Radial 40	130-500-310	-B -G -W
PVC Top cap - Radial 52 Coprigiunta in PVC - Radial 52	130-500-330	-B -G -W
PVC Top cap - Radial 65 Coprigiunta in PVC - Radial 65	130-500-330	-B -G -W





**RADIAL by Tessilmare**







Gliseris Aluminium Boats

Bino can be easily bent due to our patented two-piece design, which also allows to cover unaesthetic screws. Extremely flexible. Can be used on docks, piers, military boats, work boats and pleasure boats.

Bino è il profilo più versatile di casa Tessilmare. Grazie alla sua possente struttura offre un'alta protezione agli urti e si rende adatto alla protezione di banchine e imbarcazioni da lavoro, militari e in genere.



**STRONG**  
AND LIGHTWEIGHT



**IL FORTE**  
MA LEGGERO

**bino**

engineered by Rezzonico Massimo  
made by Tessilmare

**SUITABLE**  
FOR:

- yachts
- military boats
- tenders
- dock protection
- workboats
- pier protection





## bino40

The advantage of this product is that it can be adapted to very complex curves, with both negative and positive acute radius, the product does not need any pre-heating so the assembly is quick.

The design of the Bino 40 allows you to replace the individual components separately over time.

La particolarità di questo prodotto è quella di potersi adattare a curve molto complesse, con raggi acuti sia negativi che positivi, il prodotto non necessita riscaldamento pertanto la fase di montaggio è velocissima. La modularità di Bino 40 consente di poter sostituire nel tempo una delle due parti, indistintamente.

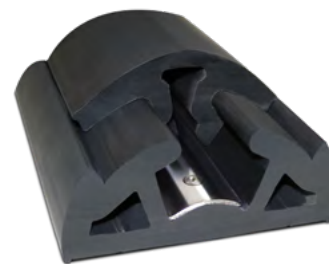

## bino65&90

Bino is supplied in custom-cut reels to avoid junctions. A pre-drilled steel bar allows easy installation of the profile base.

The top side is simply pressure fixed.

Bino è fornito in rotoli a misura dell'imbarcazione per evitare giunzioni e punti di debolezza. Si applica facilmente: la base è fissata con l'ausilio di una barra preforata in acciaio, la parte superiore è posizionabile a pressione.



24

## bino40

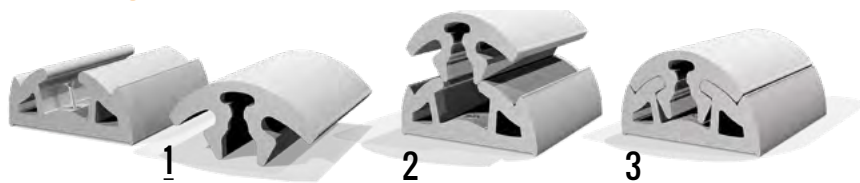

## bino90 bino65

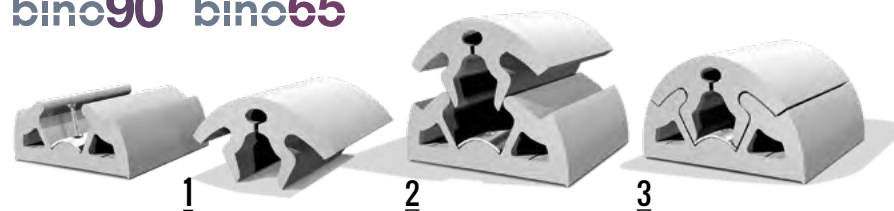

# 1

## PREPARATION OF THE PROFILE

**Bino 40** fender profile consists of 2 modules, one base and one "top" which covers the attachment hardware.

The product fits cold as its flexibility is very high.

Lay the profile on the ground around the boat or on the boat itself, the more the profile is stretched, the easier it is to install it.

## PREPARAZIONE DEL PROFILO

Il profilo **Bino 40** è costituito da 2 moduli, uno di base ed uno a "tappo" che copre le viti di fissaggio.

Il prodotto si monta a freddo dato che la sua flessibilità è molto elevata.

Distendere il profilo a terra intorno all'imbarcazione o sull'imbarcazione stessa, più il profilo sarà disteso in modo corretto più semplice sarà la sua installazione.

# 2



## FIXING THE BASE PROFILE THROUGH SCREWS AND RIVETS

Drill and screw the base profile directly to the boat.

## FISSARE LA BASE DEL PROFILO TRAMITE VITI O RIVETTI

Forare ed avvitare la base del profilo direttamente all'imbarcazione.

# 3



## APPLICATION OF THE TOP PROFILE

Install the top profile by hitting it with a rubber hammer.

## APPLICAZIONE DEL PROFILO TOP

Applicare il profilo di chiusura pressandolo con un martello di gomma.

# 4



## FINISH WITH END-CAPS

## RIFINIRE CON TERMINALI

**HOW TO BEND**  
[www.youtube.com/tessilmare](http://www.youtube.com/tessilmare)

## FITTING STEPS

**bino40**

## FITTING STEPS

bino90 bino65

### HOW TO BEND

[www.youtube.com/tessilmare](http://www.youtube.com/tessilmare)

1

#### PREPARATION OF THE PROFILE

The **Bino 90** and **Bino 65** fender profiles consist of two sections and a pre-drilled stainless-steel installation bar (sold separately). Lay the profile on the ground around the boat or on the boat itself, the more the profile is stretched, the easier it is to install it.

#### PREPARAZIONE DEL PROFILO

I profili **Bino 90** e **Bino 65** sono costituiti da 2 moduli e una barra pre-forata di fissaggio in acciaio inox.

Distendere il profilo a terra intorno all'imbarcazione o sull'imbarcazione stessa, più il profilo sarà disteso in modo corretto più semplice sarà la sua installazione.

2



#### FIXING THE TRACK THROUGH THE STEEL BAR

Drill holes in the boat using the same holes of the bars as a guide.

#### FISSARE LA BASE DEL PROFILO TRAMITE LA SUA BARRA IN ACCIAIO

Forare l'imbarcazione utilizzando i fori della barra stessa come guida.

3



#### APPLICATION OF THE TOP PROFILE

Apply the closing profile by hitting with a rubber hammer.

#### APPLICAZIONE DEL PROFILO TOP

Applicare il profilo di chiusura pressandolo con un martello di gomma.

4



#### FINISH WITH END-CAPS

#### RIFINIRE CON TERMINALI

## FEATURES

COLORS	black	grey	white
	RAL 9004	RAL 7047	RAL 9010



Lip  
Dentino

PROFILE [ PVC ]



FINISH  
stainless steel



BAR [ S/S ]

description descrizione	type tipo	item articolo	colors ● ● ○	weight peso	min bending Rad R min curvatura	packaging imballo	min. order ordine min.
Bino H 40 set of 2 pcs Bino H 40 serie 2 pezzi	with lip con dentino	130-115-001-L	-B -G -W	30 oz/yd 858 g/m	1-3/4" 45 mm	coil rotolo	78' 24 m
Bino H 40 set of 2 pcs Bino H 40 serie 2 pezzi		130-115-001	-B -G -W	27 oz/yd 850 g/m	1-3/4" 45 mm	coil rotolo	78' 24 m
Bino H 65 set of 2 pcs Bino H 65 serie 2 pezzi	with lip con dentino	130-115-005-L	-B -G -W	79 oz/yd 2.244 g/m	2-1/8" 55 mm	coil rotolo	39' 12 m
Bino H 65 set of 2 pcs Bino H 65 serie 2 pezzi		130-115-005	-B -G -W	73 oz/yd 2.060 g/m	2-1/8" 55 mm	coil rotolo	39' 12 m
Bino H 90 set of 2 pcs Bino H 90 serie 2 pezzi	with lip con dentino	130-115-010-L	-B -G -W	153 oz/yd 4.345 g/m	2-3/4" 70 mm	coil rotolo	39' 12 m
Bino H 90 set of 2 pcs Bino H 90 serie 2 pezzi		130-115-010	-B -G -W	145 oz/yd 4.115 g/m	2-3/4" 70 mm	coil rotolo	39' 12 m
S/S Bar 2 mts. long Barra in acciaio da 2 m		130-110-165	-B -G -W	10 oz/yd 300 g/m			

## ACCESSORIES

COLORS	black	grey	white
	RAL 9004	RAL 7047	RAL 9010



END CAPS [ PVC ]

description descrizione	item articolo	colors ● ● ○
PVC End cap - BINO 65 Terminale in PVC - Bino 65	130-500-092	-B -G -W
PVC End cap - BINO 90 Terminale in PVC - Bino 90	130-500-095	-B -G -W

FINISH  
stainless steel

END CAPS [ S/S ]



TOP CAPS [ S/S ]

description descrizione	item articolo
S/S Top cap - Bino 40 Coprigiunta in acciaio - Bino 40	130-500-615
S/S End cap - Bino 40 Terminale in acciaio - Bino 40	130-500-515
S/S End cap - Bino 65 Terminale in acciaio - Bino 65	130-500-570
S/S End cap - Bino 90 Terminale in acciaio - Bino 90	130-500-575





**BINO by Tessilmare**







Ferretti Security Division

Bumper is the first fender profile that represents the perfect alliance between lightweight and power. Developed with a triple structure of PVC, it has wide inner air gaps creation absorption of impacts never been reached before.

Bumper è il potente profilo parabordo che si distingue per l'assoluta leggerezza. Concepito con una triplice struttura in pvc con ampie camere d'aria interne, Bumper raggiunge una capacità di assorbimento agli urti senza precedenti.

**STRONG**  
BUT LIGHTWEIGHT



**FORZA**  
E LEGGEREZZA

# bumper

engineered by Rezzonico Massimo  
made by Tessilmare





## EASY INSTALLATION

Thanks to the Bumpers unique three-piece design, it can be easily installed. Both base profiles are fixed to the hull with a stainless-steel bar and the top profile is fitted by pressure.

Può essere applicato facilmente grazie alla sua componibilità: i due profili di base sono fissati allo scafo con l'ausilio di una barra in acciaio, la parte centrale è posizionabile a pressione.



**SUITABLE  
FOR:**

- yachts
- military boats
- tenders
- dock protection
- workboats
- pier protection



30

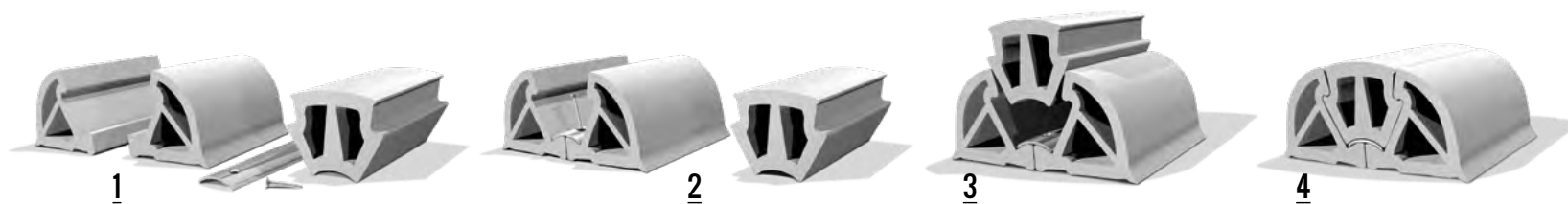



1

## PREPARATION OF THE PROFILE

The Bumper fender profile consists of three sections and a pre-drilled stainless-steel installation bar.

Lay the profile on the ground around the boat or on the boat itself, the more the profile is properly stretched, the easier it is to install it.

## PREPARAZIONE DEL PROFILO

Il profilo Bumper è costituito da 3 moduli e una barra pre-forata di fissaggio in acciaio inox. Distendere il profilo a terra intorno all'imbarcazione o sull'imbarcazione stessa, più il profilo sarà disteso in modo corretto più semplice sarà la sua

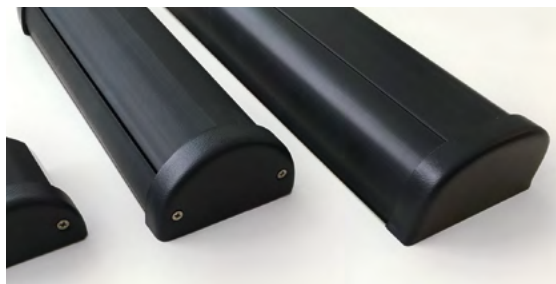
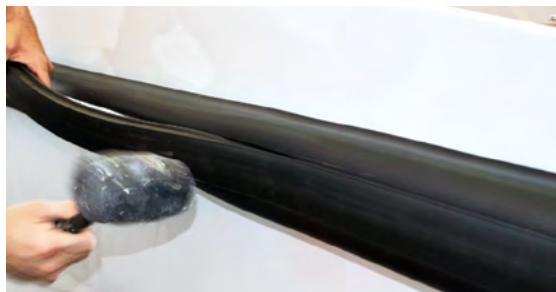
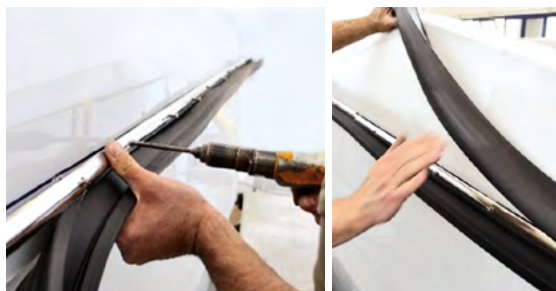

2

## ATTACHING THE STEEL BAR

Place the fender profile and the steel bar and mark the correct position of the bar with a felt-tip pen. Drill holes in the boat using the holes in the bars as a guide and start the track screws over the entire circumference of the boat. Do not fully tighten at this time, you will need to first install the base modules in Step #3.

3

## APPLICATION OF THE BASE MODULES

The modules must be placed perfectly under the steel bar. The two base modules are attached, finish tightening the screws on the steel bar down to complete the full base installation.

4

## APPLICATION OF THE TOP PROFILE

Install the top module portion of the profile by hitting it with a rubber hammer.

5

## FINISH WITH END CAPS

## FITTING STEPS

### FISSARE IL BINARIO IN ACCIAIO

Posizionare il profilo e la barra di fissaggio segnando la posizione corretta della parte metallica con un pennarello. Forare l'imbarcazione utilizzando i fori del binario stesso come guida, puntare le viti del binario su tutta la circonferenza dell'imbarcazione.

### APPLICAZIONE DEI MODULI DI BASE

Applicare uno dei due moduli di base, avvitando le viti fino a quando il profilo rimane posizionato. Applicare il secondo modulo di base e successivamente avvitare le viti fino a completo fissaggio dei moduli. I moduli dovranno essere inseriti perfettamente sotto il binario.



### APPLICAZIONE DEL PROFILO TOP

Applicare il Profilo di chiusura pressandolo con un martello di gomma.

### RIFINIRE CON TERMINALI

## FEATURES

**COLORS**

		
black	grey	white
RAL 9004	RAL 7047	RAL 9010





**PROFILE [ PVC ]**

**FINISH**

stainless steel





**BAR [ S/S ]**

description descrizione	series serie	item articolo	colors   	weight peso	min bending Rad R min curvatura	packaging imballo	min. order ordine min.
Bumper H 100	3 pieces 3 pezzi	<b>130-110-100</b>	-B -G -W	135 oz/yd 3.800 g/m	5-1/2" 140 mm	coil rotolo	39' 12 m
Bumper H 125	3 pieces 3 pezzi	<b>130-110-125</b>	-B -G -W	180 oz/yd 5.100 g/m	5-7/8" 150 mm	coil rotolo	39' 12 m
Bumper H 150	3 pieces 3 pezzi	<b>130-110-150</b>	-B -G -W	240 oz/yd 6.700 g/m	6-1/4" 160 mm	coil rotolo	39' 12 m
Bumper H 160	3 pieces 3 pezzi	<b>130-110-160</b>	-B -G -W	310 oz/yd 8.850 g/m	7-1/8" 180 mm	coil rotolo	39' 12 m

description descrizione	item articolo	weight peso	length lunghezza	height altezza	min. order ordine min.
S/S Bar for Bumper 100 and 125 Barra acciaio - Bumper 100 e 125	<b>130-110-165</b>	10 oz/yd 300 g/m	7' 2 m	1" 25 mm	39' 12 m
S/S Bar for Bumper 150 and 160 Barra acciaio - Bumper 150 e 160	<b>130-110-170</b>	10 oz/yd 350 g/m	7' 2 m	1" 28 mm	39' 12 m



## ACCESSORIES

**COLORS**

		
black	grey	white
RAL 9004	RAL 7047	RAL 9010



**END CAPS [ PVC ]**

description descrizione	model modello	item articolo	colors   
PVC End cap Terminale in PVC	Bumper 100	<b>130-500-096</b>	-B -G -W
PVC End cap Terminale in PVC	Bumper 125	<b>130-500-097</b>	-B -G -W
PVC End cap Terminale in PVC	Bumper 150	<b>130-500-098</b>	-B -G -W
PVC End cap Terminale in PVC	Bumper 160	<b>130-500-099</b>	-B -G -W





**BUMPER by Tessilmare**





## DOCK FENDERS



**DOCK 90/60**



**DOCK 72**

description descrizione	item articolo	colors ● ● ○	weight peso	min. order ordine min.
Dock fender 60 mm Protezione pontili 60 mm	130-100-005	-B -G -W	56 oz/yd 1.760 g/m	330' 100 m
Dock fender 90 mm Protezione pontili 90 mm	130-100-015	-B -G -W	109 oz/yd 3.420 g/m	330' 100 m
Dock fender 72 mm Protezione pontili 72 mm	130-060-090	-B -G -W	70 oz/yd 2.200 g/m	330' 100 m

## PROFILES FOR TRAILERS



COLORS	black	grey	white
RAL	9004	7047	9010

description descrizione	item articolo	colors ● ● ○	weight peso	min. order ordine min.
Profiles for launching cradles 40 mm Profilo per invasature 40 mm	130-090-005	-B -G -W	18 oz/yd 550 g/m	660' 200 m
Profiles for launching cradles 60 mm Profilo per invasature 60 mm	130-090-010	-B -G -W	41 oz/yd 1.300 g/m	660' 200 m
Profiles for launching cradles 80 mm Profilo per invasature 80 mm	130-090-015	-B -G -W	70 oz/yd 2.200 g/m	660' 200 m

## L SERIES

**WITHOUT "T"**  
RIGID SUPPORT



**WITH "T"**  
RIGID SUPPORT

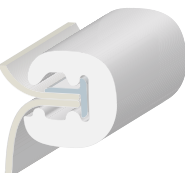

**"T"**  
RIGID SUPPORT

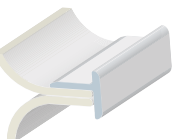

FENDER PROFILE			
model modello	item articolo	weight peso	min. order ordine min.
L28	130-005-001	18 oz/yd 560 g/m	985' 300 m
L30	130-005-005	17 oz/yd 530 g/m	985' 300 m
L32	130-005-010	24 oz/yd 760 g/m	985' 300 m
L35	130-005-015	35 oz/yd 1.100 g/m	196' 60 m
L45	130-005-020	48 oz/yd 1.500 g/m	196' 60 m
L50	130-005-025	51 oz/yd 1.590 g/m	392' 120 m

ACCESSORIES			
description descrizione	item articolo	description descrizione	item articolo
End cap Terminale	130-500-070	Top Cap Coprigiunta	130-500-370
End cap Terminale	130-500-070	Top Cap Coprigiunta	130-500-370
End cap Terminale	130-500-050	Top Cap Coprigiunta	130-500-370
End cap Terminale	130-500-050	Top Cap Coprigiunta	130-500-370
End cap Terminale	130-500-080	Top Cap Coprigiunta	130-500-350
End cap Terminale	130-500-080	Top Cap Coprigiunta	130-500-350

RIGID SUPPORT			
description descrizione	item articolo	bar lengths L barra	packaging imballo
T16	130-010-005	6' 2 m	196' 60 m
T18	130-010-010	6' 2 m	196' 60 m
T22	130-010-015	6' 2 m	196' 60 m
T22	130-010-015	6' 2 m	196' 60 m

# RELINGA RAILS

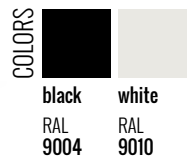

Rail for fixing sun-tops by means of a "relinga" insert colour white or black.

Canalina per il fissaggio delle capottine tramite un inserto a relinga colore bianco o nero.

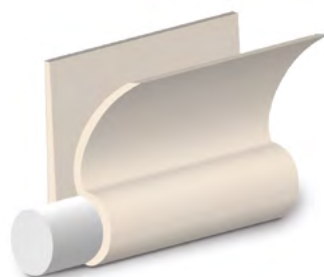

Insert in extra soft PVC material.

Tondi per la realizzazione di inserti relinga in PVC extramorbido.

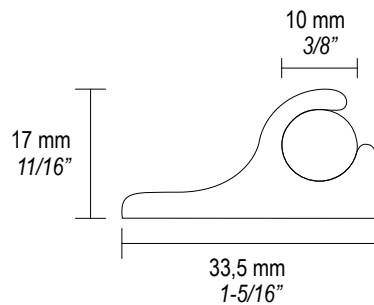
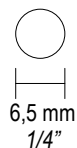
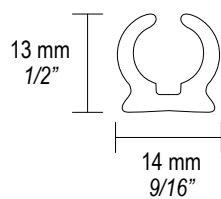

TESSILMARE

# CUSHIONS RAILS



description descrizione	item articolo	colors ○ ●	weight peso	min. order ordine min.
Relinga rail Canalina per relinga	140-050-057	○	6 oz/yd 190 g/m	196' 60 m
Relinga rail Canalina per relinga	140-050-057-NE	●	6 oz/yd 190 g/m	196' 60 m
Insert for relinga rail Inserto per canalina	140-050-059	○	2 oz/yd 51 g/m	196' 60 m
Cushion profile - bars of 4 m Profilo per cuscineria - barre 4 m	140-050-058	○	10 oz/yd 280 g/m	196' 60 m
Cushion profile - bars of 4 m Profilo per cuscineria - barre 4 m	140-050-058-NE	●	10 oz/yd 280 g/m	196' 60 m

# TECHNICAL GUIDE



For installation on  
**flat surfaces**



For installation with  
**deck joint**



**binOX**

engineered by Rezzonico Ranieri  
made by Tessilmare



For installation on  
**flat surfaces**



For installation with  
**deck joint**

**WITHOUT LIP  
SENZA DENTINO**

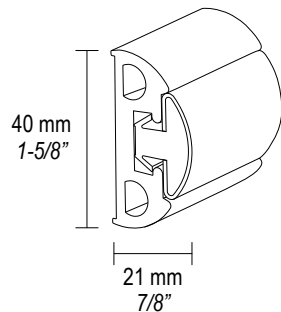

**BINOX 25**

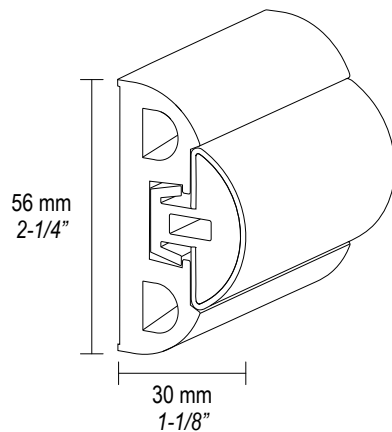

**BINOX 35**

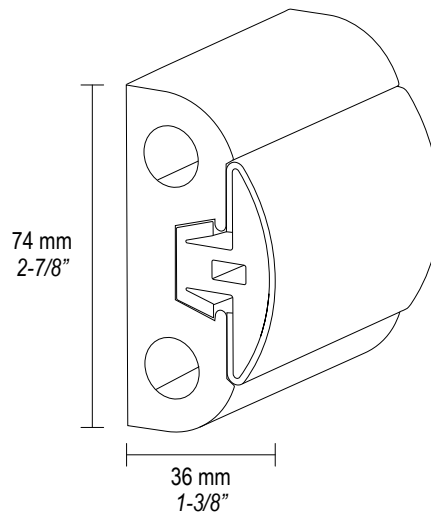

**BINOX 50**

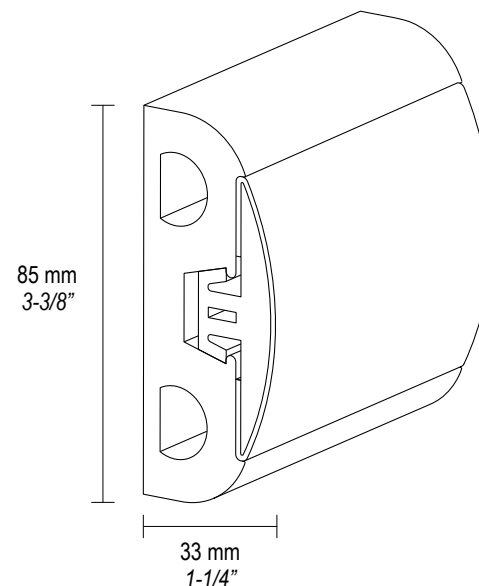

**BINOX 65**

**WITH LIP  
CON DENTINO**

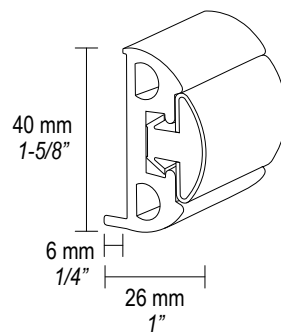

**BINOX 25**

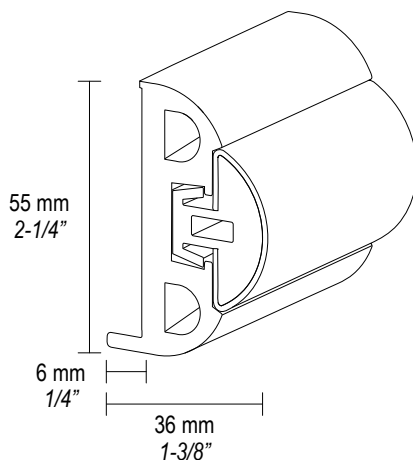

**BINOX 35**

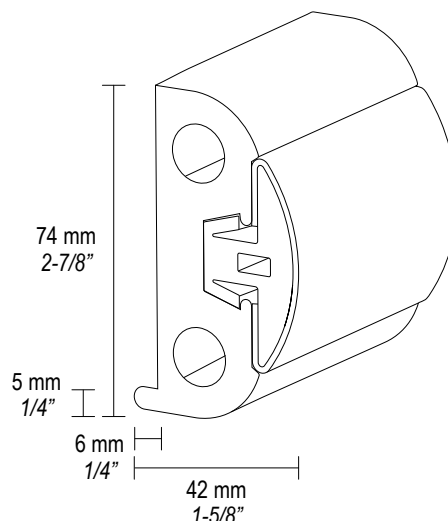

**BINOX 50**

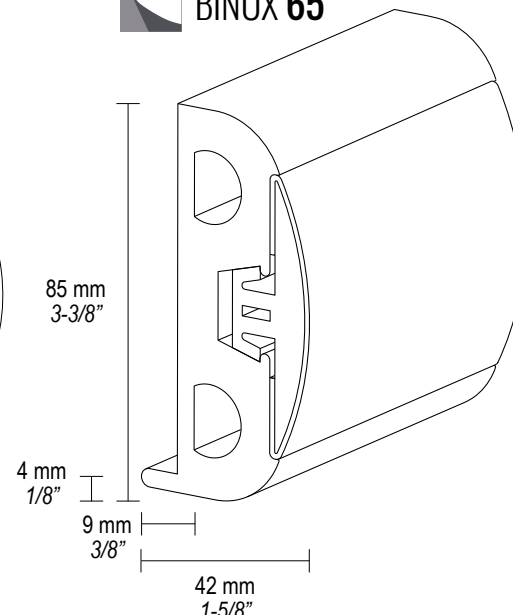

**BINOX 65**



For installation on  
**flat surfaces**



For installation with  
**deck joint**

**WITHOUT LIP**  
**SENZA DENTINO**

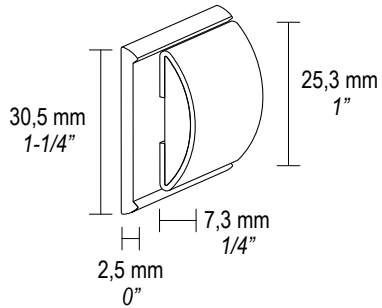

**SPHAERA SLIM 25**

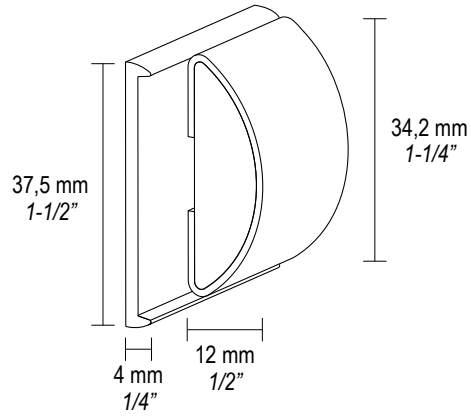

**SPHAERA SLIM 35**

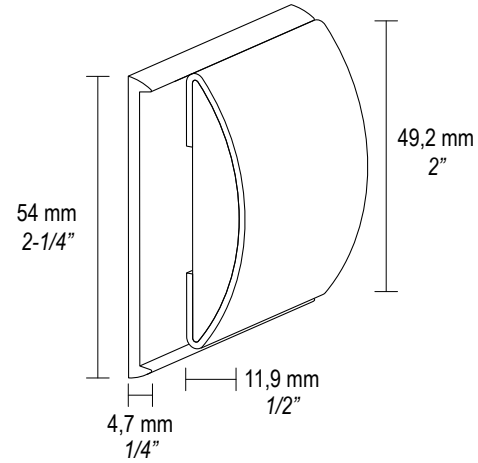

**SPHAERA SLIM 50**

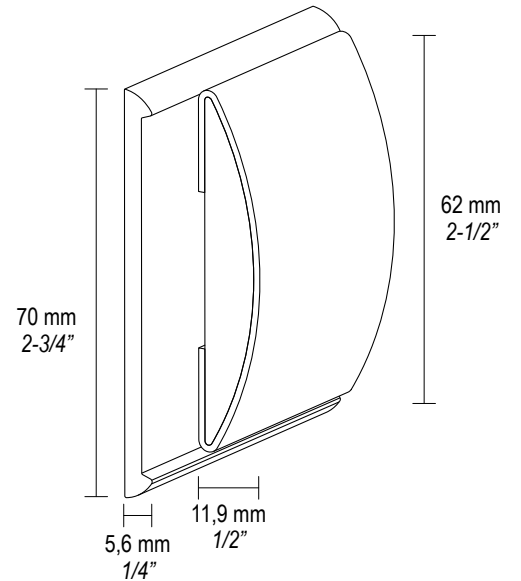

**SPHAERA SLIM 65**

**WITH LIP**  
**CON DENTINO**

**38**

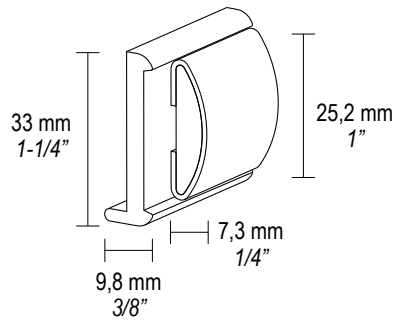

**SPHAERA SLIM 25**

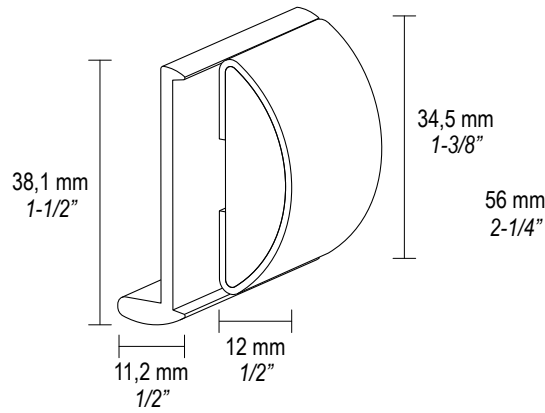

**SPHAERA SLIM 35**

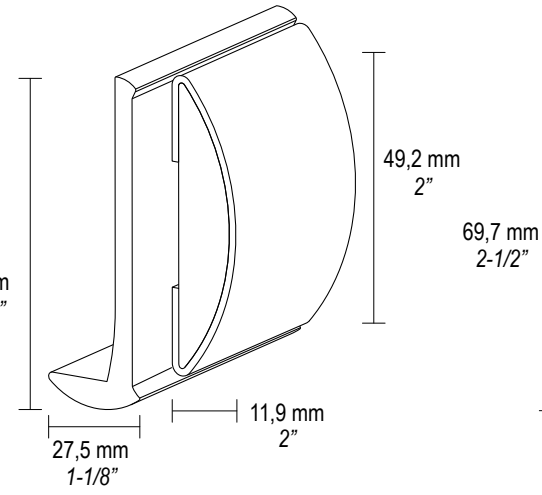

**SPHAERA SLIM 50**

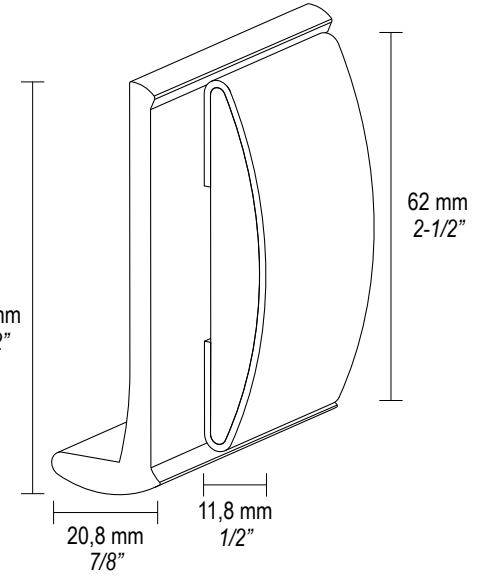

**SPHAERA SLIM 65**



For installation on  
**flat surfaces**



For installation with  
**deck joint**

**WITHOUT LIP**  
**SENZA DENTINO**

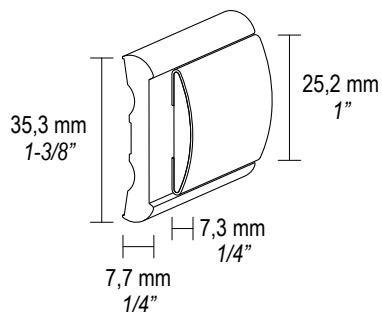

**SPHÆRA 25**

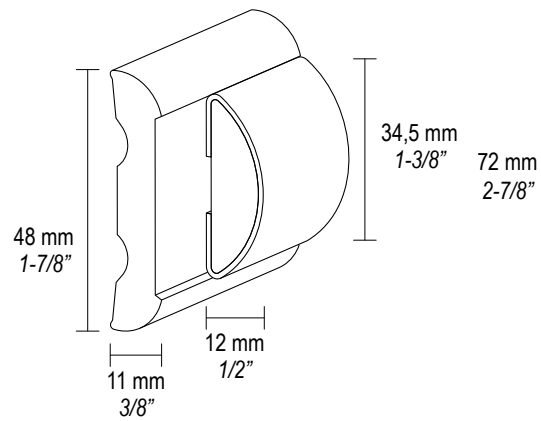

**SPHÆRA 35**

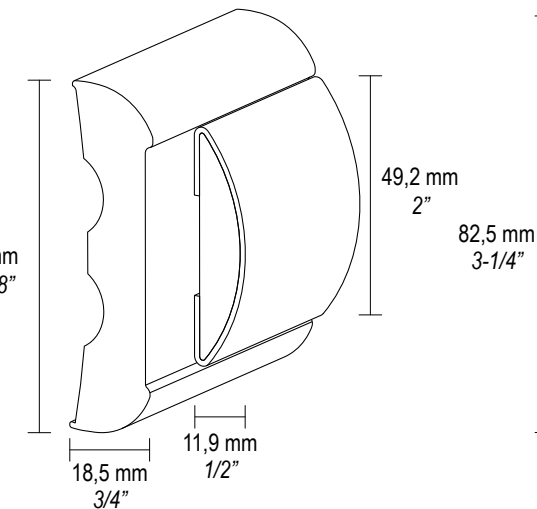

**SPHÆRA 50**

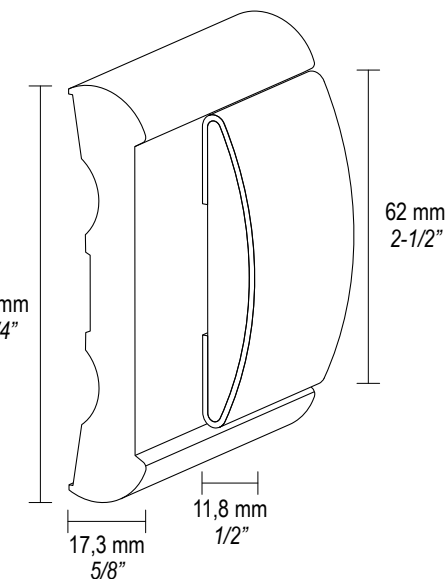

**SPHÆRA 65**

**WITH LIP**  
**CON DENTINO**

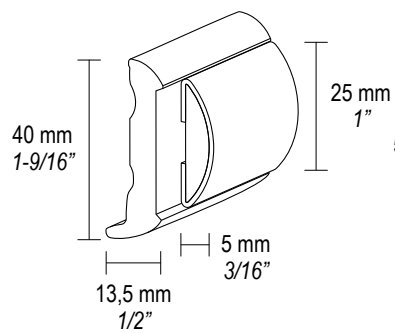

**SPHÆRA 25**

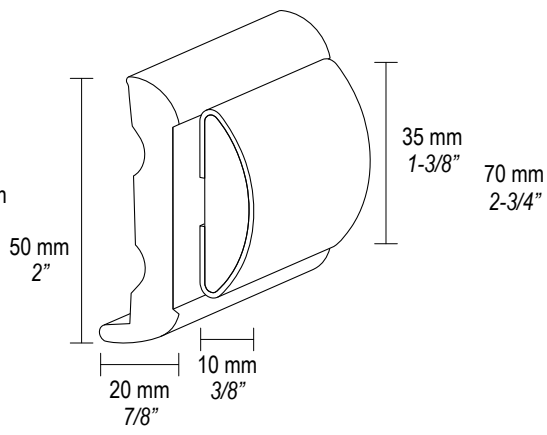

**SPHÆRA 35**

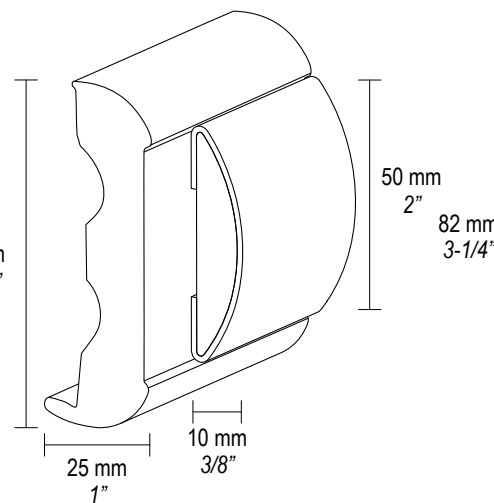

**SPHÆRA 50**

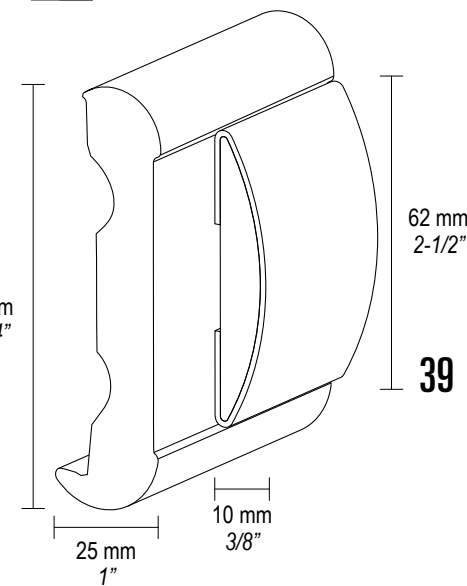

**SPHÆRA 65**





engineered by Rezzonico Massimo  
made by Tessilmare



For installation with  
**deck joint**

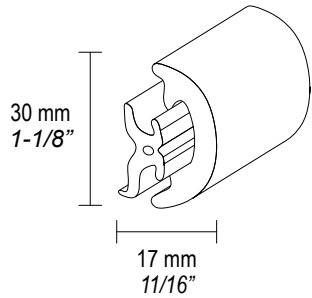

**RADIAL 30**

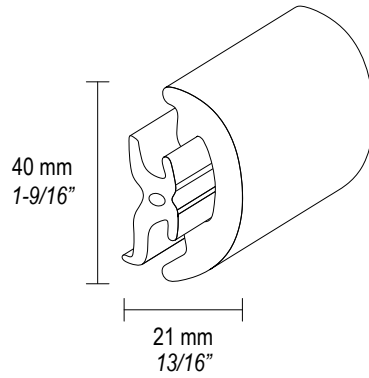

**RADIAL 40**

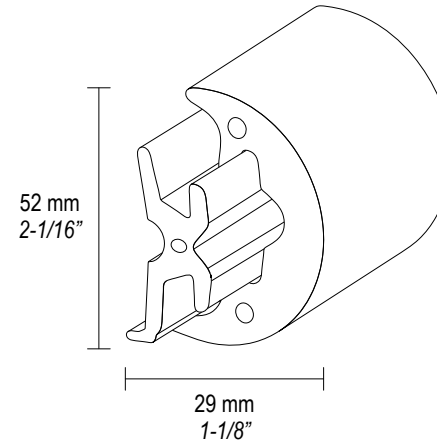

**RADIAL 52**

**40**

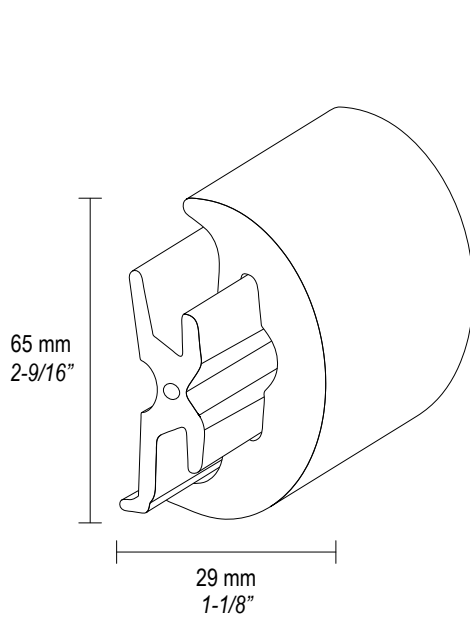

**RADIAL 65**

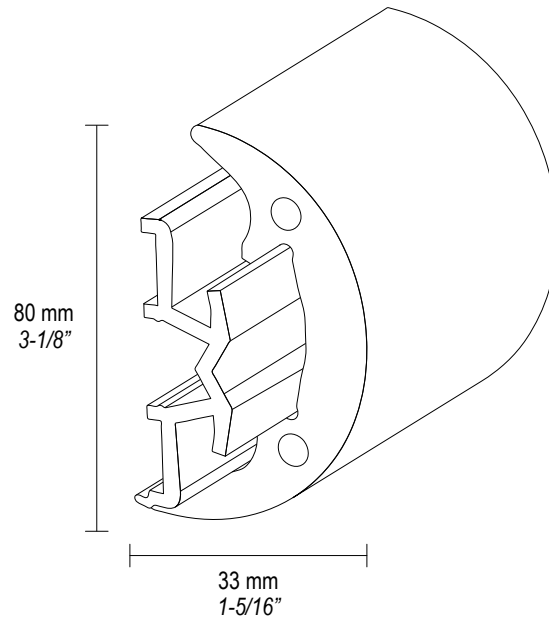

**RADIAL 80**

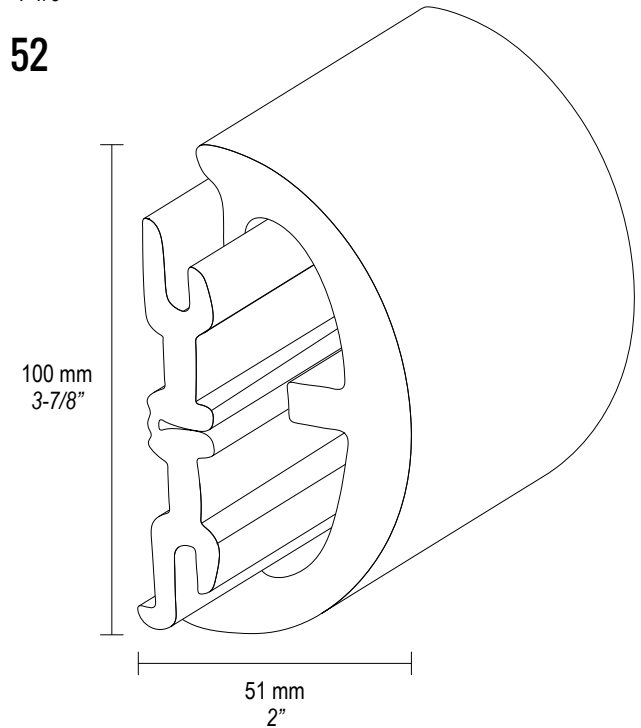

**RADIAL 100**

**binco**

engineered by Rezzonico Massimo  
made by Tessilmare



For installation on  
**flat surfaces**



For installation with  
**deck joint**

**WITHOUT LIP**  
**SENZA DENTINO**

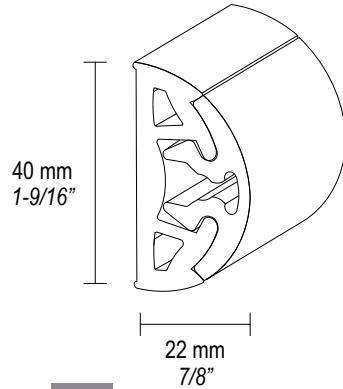

**BINO 40**

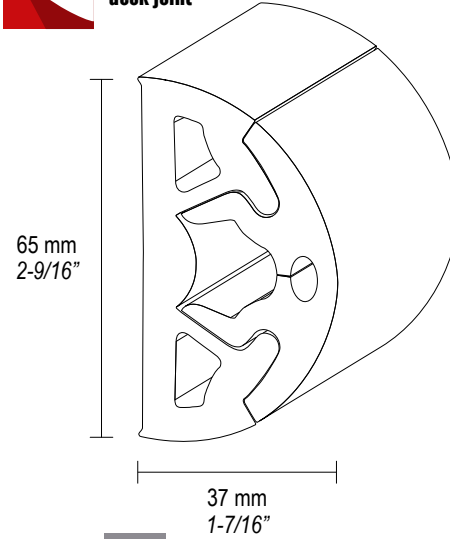

**BINO 65**

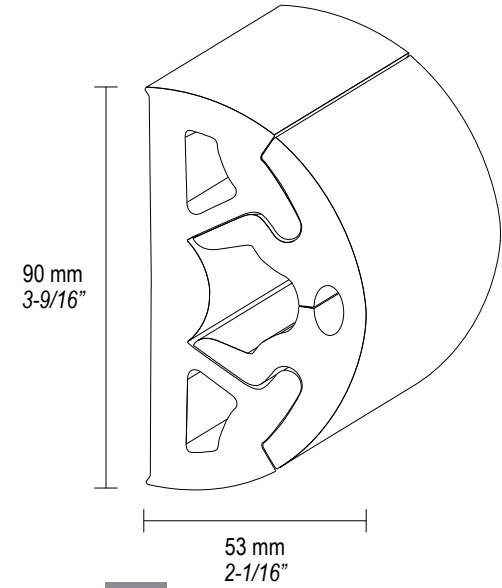

**BINO 90**

**WITH LIP**  
**CON DENTINO**

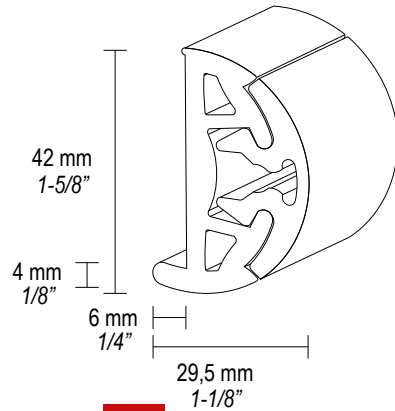

**BINO 40**

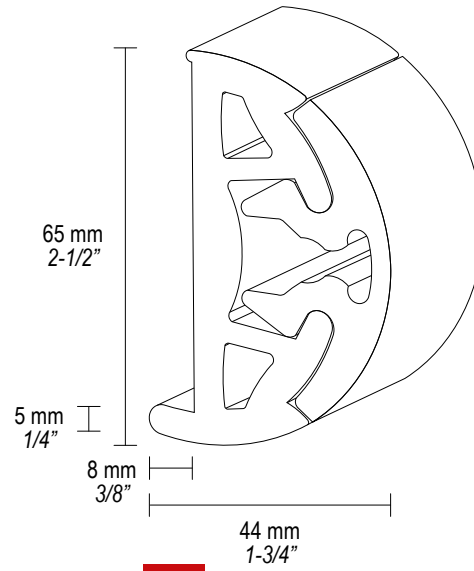

**BINO 65**

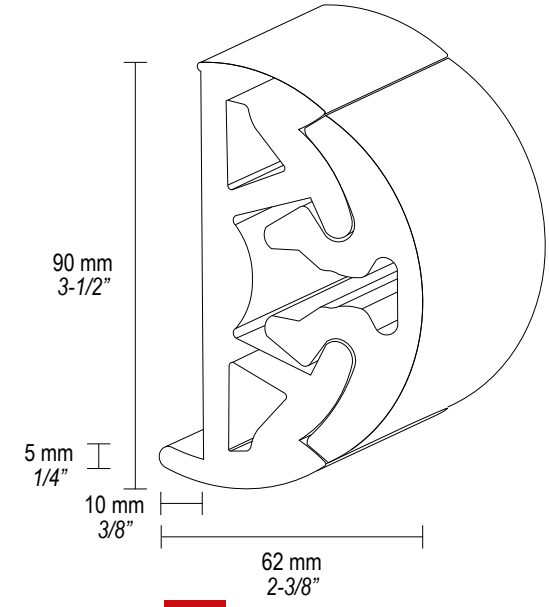

**BINO 90**

# bumper

engineered by Rezzonico Massimo  
made by Tessilmare



For installation on  
**flat surfaces**

42

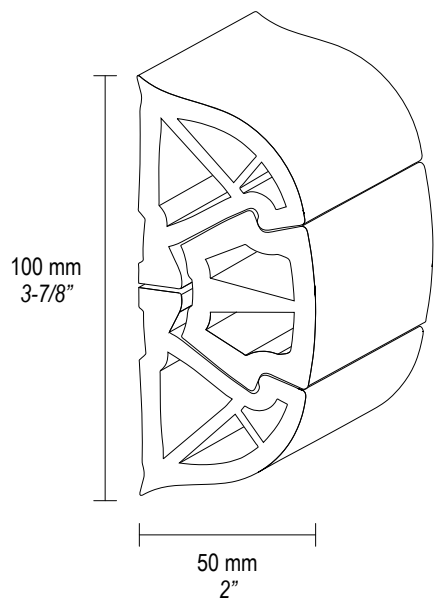

**BUMPER 100**

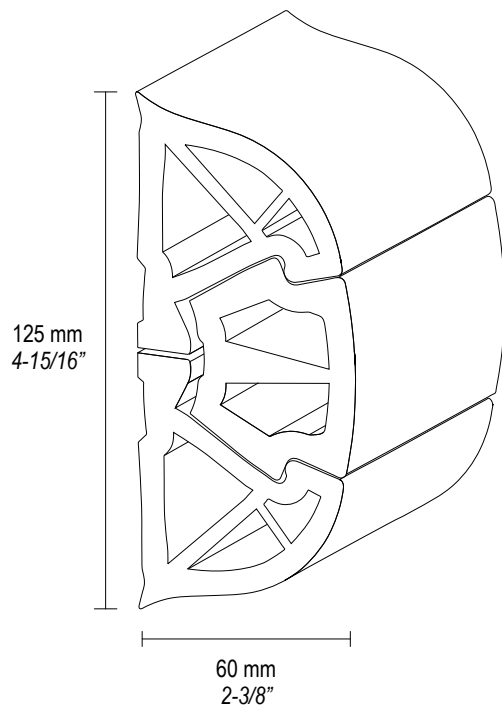

**BUMPER 125**

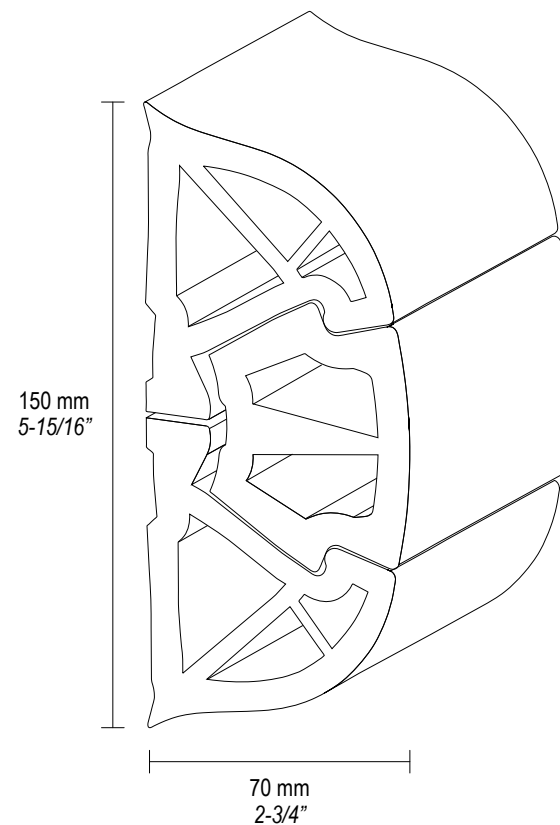

**BUMPER 150**



# L SERIES

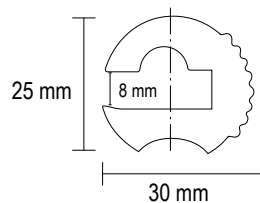

**L 28**

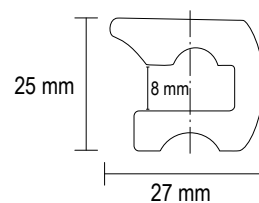

**L 30**

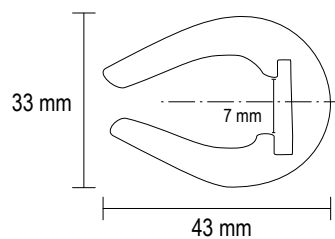
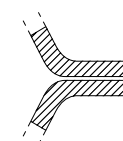

**L 32**

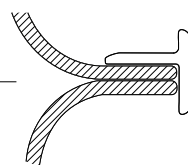

**T 16**

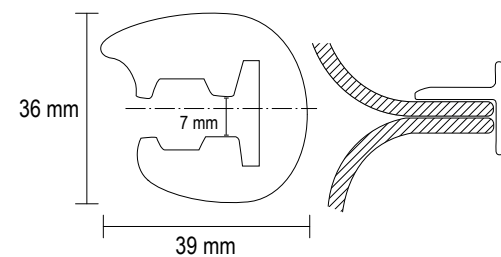

**L 35**

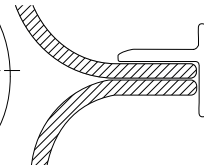

**T 18**

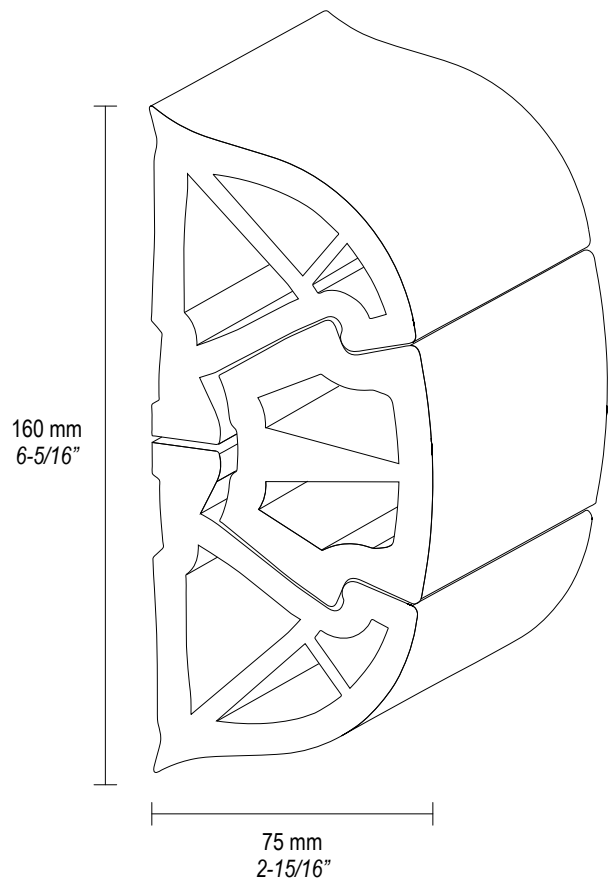

**BUMPER 160**

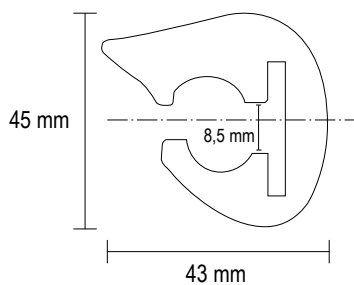

**L 45**

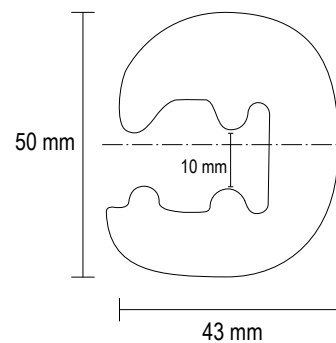

**L 50**

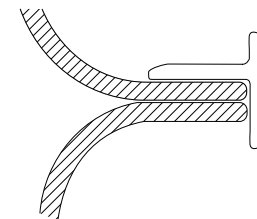

**T 22**

Tessilmare is a family-owned and operated company located in Italy, specializing in the production of Rub Rails since 1947.

At Tessilmare we specialize in producing only the best high-quality Rub Rails. Many companies like to focus on a large variety of different products, but at Tessilmare we prefer to do a smaller number of products to an exceptionally high standard.

We utilize **special Patented profiles** to give our customers an excellent product, perfect in every detail and dimension. We have revolutionized the world of Rub Rails, giving consumers around the world a complete range of versatile, cost-effective profiles within easy reach.

All the Rub Rails we manufacture at Tessilmare are engineered for Mega Yachts, Work and Utility Boats, Pleasure Boats, Commercial and Military Boats.

Rub Rails are also ideal for wharves, and dock protection in marinas and high-traffic areas.

Tessilmare è un'azienda a conduzione familiare con sede in Italia, specializzata nella produzione di Profili Parabordo dal 1947.

In Tessilmare siamo specializzati nella produzione solo dei migliori Profili Parabordo di alta qualità. Molte aziende propongono una grande varietà di prodotti, ma in Tessilmare preferiamo concentrarci su un numero inferiore con uno standard eccezionalmente alto.

Utilizziamo **speciali profili brevettati** per dare ai nostri clienti un prodotto eccellente, perfetto in ogni dettaglio e dimensione.

Abbiamo rivoluzionato il mondo dei Profili Parabordo, offrendo ai clienti di tutto il mondo una gamma completa di profili versatili ed economici.

Tutti i Profili Parabordo che produciamo in Tessilmare sono progettati per Mega Yachts, Barche da Lavoro, Barche da diporto, Barche Commerciali e Militari. Sono anche ideali per moli e pontili e la loro protezione nei porti turistici e

The use of our Rub Rails is not limited to the marine field, we have customers in the building, hospital, and transportation fields.

At Tessilmare we use only the best raw materials. This gives our range of Rub Rails high resistance to marine waters, low and high temperatures, and extreme weather conditions. We are very flexible with production, which means we save you money by producing custom lengths of Rub Rails. Less waste means more money in your pocket!

We utilize a worldwide list of distributors to ensure that no matter where you are located, you will be able to purchase the best range of Rub Rails on the market.

Tessilmare has also a specialized branch located in Florida, USA, giving us the ability to ship around North America.



nelle aree ad alto traffico.

L'utilizzo dei nostri Profili Parabordo non è comunque limitato al settore nautico, abbiamo clienti nel settore edile, ospedaliero e dei trasporti.

In Tessilmare utilizziamo solo le migliori materie prime. Ciò conferisce alla nostra gamma di Profili Parabordo un'elevata resistenza alle acque marine, alle basse e alte temperature e alle condizioni meteorologiche estreme. Siamo molto flessibili con la produzione, il che significa che produciamo i nostri profili in lunghezze personalizzate permettendo ai nostri clienti di risparmiare denaro. Meno sprechi significa più soldi in tasca!

Collaboriamo con numerosi distributori in tutto il mondo per garantire che, indipendentemente da dove ci si trovi, si possa acquistare la migliore gamma di Profili Parabordo sul mercato.

Tessilmare ha anche una filiale specializzata situata in Florida, USA, che permette di spedire in tutto il Nord America.







via V. Veneto, 15  
23896 Bevera di Sirtori (Lecco) - Italy  
Tel. +39 039.92.15.71 Fax +39 039.92.10.483  
[www.rubrails-tessilmare.com](http://www.rubrails-tessilmare.com) [www.tessilmare.com](http://www.tessilmare.com)  
[info@tessilmare.com](mailto:info@tessilmare.com)

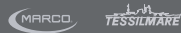

MATE USA LLC.  
3251-A S.W. 13<sup>th</sup> Drive - Deerfield Beach  
FL 33442 U.S.A.  
Ph. (+1) 954.463.5757 Fax (+1) 954.463.5635  
[www.mate-usa.com](http://www.mate-usa.com) [info@mate-usa.com](mailto:info@mate-usa.com)