

scott **aerator**
water in motion

**Solar Powered System
for 3/4 HP DA-20 and
3/4 HP Boilermaker**



A few words about the product

Thank you for purchasing this Scott Aerator Solar Powered product. This completely sustainable system is a cost effective alternative to a direct wired power source. Now you can enjoy a clean pond or waterway without having to run expensive electrical lines to remote locations.

The Photon™ Drive is a variable speed motor drive designed to run Scott Aerator's 3/4 HP DA-20 or Boilermaker specially equipped with a Franklin Electric three-phase submersible induction motor. The solar array is composed of a Universal Top of Pole Mount (UTPM) frame, four Type G PV modules and all necessary wiring components. The Universal Top-of-Pole support structure mounts on 4 inch SCH40/80 galvanized steel pipe and concrete footing which is not included (installer supplied).

Location:

- Choose location that allows optimal access to sun facing South.
- Clear obstructions that will obscure direct sunlight (Be aware of smaller trees and bushes that may grow into path of desired sunlight)
- Plan accordingly for ensuring a stable foundation in sloped, soft or wet locations
- Choose location that offers the shortest path to your water feature (under 150 feet)

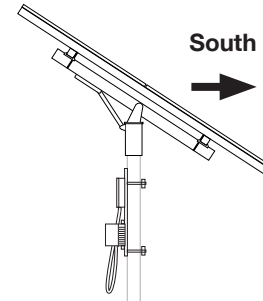

Foundation:

Prior to assembly, it is important to set the foundation properly to maintain a solid and stable base for the solar array. Foundation requirements are dependent on several factors including wind speed, exposure category, soil type, steepest expected tilt angle, and above-ground clearance. For foundation recommendations on your specific installation, please contact the manufacturer at: Phone: (608)272-3999 Email: info@ussolarmounts.us

- Set solid concrete foundation below and above grade to site specific requirements and/or codes
- Include rebar reinforcement
- Ensure foundation is plumb and pole collar is level
- Allow foundation to cure for 3 days

Pole:

- Use 4" galvanized or stainless steel pole
- Plan for lowest installation possible while maintaining flood and or snow clearance from electrical components
- Allow for minimum 18" clearance between top disconnect and solar PV panels to protect against overheating electrical controls
- Make sure pole is plumb to ground

Maintenance:

- Be sure to keep obstructions clear throughout the year.
- To maximize performance, periodically clean the PV panels with water only

About these Assembly Instructions

These instructions...

- Are intended to be used by individuals with sufficient technical skills for the task. Knowledge and use of hand tools, measuring devices and torque values is also required.
- Include various precautions in the forms of Notes, Cautions, and Warnings. These are to assist in the assembly process and/or to draw attention to the fact that certain assembly steps may be dangerous and could cause serious personal injury and/or damage to components.

Following the step-by-step procedures and these precautions should minimize the risk of any personal injury or damage to components while making the installation not only safe but an efficient process.

WARNING: Follow the procedures and precautions in these instructions carefully.

Follow all local and national codes when installing this product

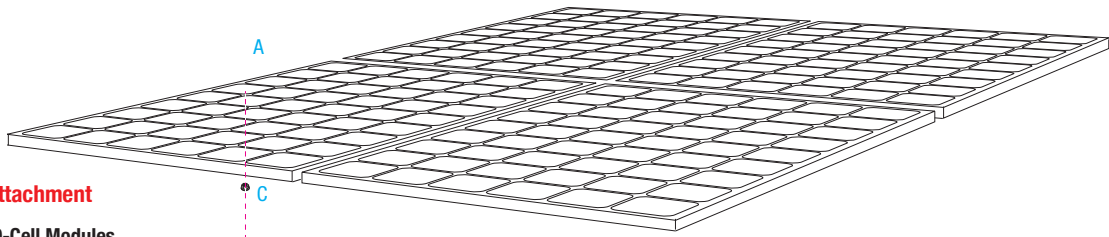

Solar Panels Attachment

- A (4) PV Panels, 60-Cell Modules, Solar Panels with Positive and Negative Connectors
- B (16) 5/16"-18 x 1-3/4" Carriage Head Bolts
- C (16) 5/16" 18 Serrated Flange Nuts

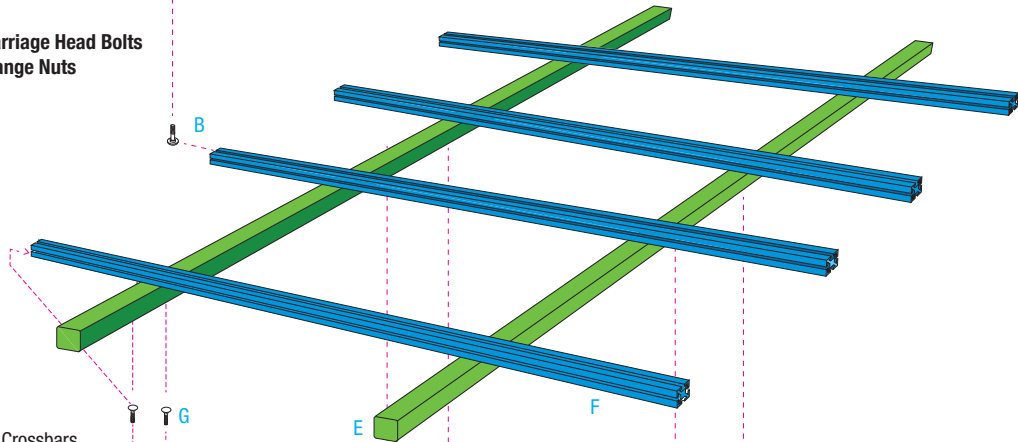

Rail/Cross Bar Assembly

- D Strong Back
- E (2) 2" Square Tube x 120" Crossbars
- F (4) 1.5" Aluminum Rails x 80"

Rail to Cross Bar Clamps

- G (16) 5/16"-18 x 3/4" Carriage Head Bolts
- H (8) 2" Rail Straps, Rail Clamps
- I (16) 5/16"-18 Serrated Flange Nuts

Cross Bar to Strong Back Clamps

- J (8) 5/16"x 3" U-Bolts
- K (16) 5/16" Flat Washers
- L (16) 5/16" 18 Serrated Flange Nuts

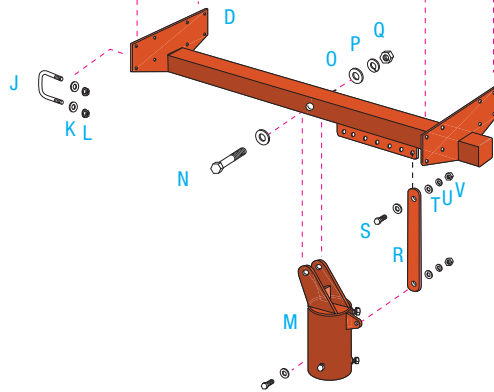
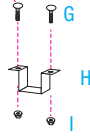

Pole Top Assembly

- M Mounting Sleeve
- N (1) 3/4"x 5-1/2" Pivot Bolt
- O (2) 3/4" Flat Washers
- P (1) 3/4" Lock Washer
- Q (1) 3/4" Nut

- R Support Arm
- S (2) 3/8"x 1-3/4" Bolts
- T (4) 3/8" Flat Washers
- U (2) 3/8" Lock Washers
- V (2) 3/8" Nuts

4" SCH40/80
3.5" O.D.
Galvanized Steel Pipe
(Installer Supplied)

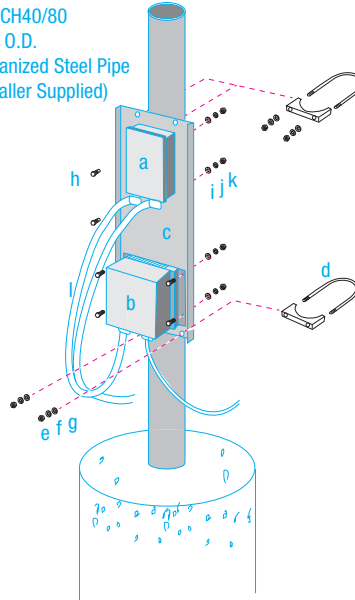

Power and Control Assembly

- a Solar Disconnect, DC Disconnect
- b Photon Drive
- c Control Mounting Plate
- d (2) 4" Clamping U-Bolts
- e (4) 1/2" Flat Washers
- f (4) 1/2" Lock Washers
- g (4) 1/2" Nuts
- h (6) 1/4"-20 x 3/4" Hex Bolts
- i (6) 1/4" Flat Washers
- j (6) 1/4" External-Tooth Lock Washers
- k (6) 1/4"-20 Hex Nuts
- l Solar Whip
- 10' Pair of PV Wire Leads w/ MC4 Connector M/F (not shown)
- 4 ft Copper Grounding Wire (not shown)

Required Tools

7/16" wrench or socket for 1/4" module hardware
9/16" wrench or socket for 3/8" hardware
3/4" wrench or socket for 1/2" hardware
1-1/8" wrench or socket for 3/4" Pivot Bolt hardware
Torque wrench

Ratchet wrench
Ratchet extension bar
3 to 6' level
Tape Measure
Square

NOTE:

Please check to make sure your kit has all parts before proceeding with installation.

ATTENTION

IMPORTANT INFORMATION FOR INSTALLERS OF THIS EQUIPMENT!

THIS EQUIPMENT IS INTENDED FOR INSTALLATION BY TECHNICALLY QUALIFIED PERSONNEL. FAILURE TO INSTALL IT IN COMPLIANCE WITH NATIONAL AND LOCAL ELECTRICAL CODES AND WITHIN FRANKLIN ELECTRIC RECOMMENDATIONS, MAY RESULT IN ELECTRICAL SHOCK OR FIRE HAZARD, UNSATISFACTORY PERFORMANCE, AND EQUIPMENT FAILURE. FRANKLIN INSTALLATION INFORMATION IS AVAILABLE FROM PUMP MANUFACTURERS AND DISTRIBUTORS AND DIRECTLY FROM FRANKLIN ELECTRIC.

WARNING

SERIOUS OR FATAL ELECTRICAL SHOCK MAY RESULT FROM FAILURE TO CONNECT THE MOTOR, CONTROL ENCLOSURES, METAL PLUMBING, AND ALL OTHER METAL NEAR THE MOTOR OR CABLE TO A PROPER EARTH GROUND IN ACCORDANCE WITH LOCAL CODES, USING WIRE NO SMALLER THAN MOTOR CABLE WIRES. TO REDUCE RISK OF ELECTRICAL SHOCK, DISCONNECT POWER BEFORE WORKING ON OR AROUND THE WATER SYSTEM. DO NOT USE MOTOR IN SWIMMING AREAS.

WARNING

High voltages (both AC and DC) capable of causing severe injury or death by electrical shock are present in this unit. The supplied disconnect switch is required to de-energize the equipment before servicing. This unit should only be installed or serviced by technically qualified professionals.

Anytime working on or near the Photon™ Drive, or system:

- Turn OFF the external DC rated disconnect from the solar array to the Photon™ drive controller.
- Securely cover the solar array with an opaque tarp.
- Wait a minimum of 5 minutes after removing power from the Photon™ Drive before servicing.

This equipment must not be used by children or persons with reduced physical, sensory or mental abilities, or lacking in experience and expertise, unless supervised or instructed. Children may not use the equipment, nor may they play with the unit or in the immediate vicinity.

WARNING

Solar panels that have been exposed to full solar insolation for an extended period of time can achieve high temperatures and could be a potential source of burns to exposed skin if contacted. Use caution when working around solar arrays.

Photon™ Drive and Disconnect Overview

The Photon Drive is a variable speed motor drive designed to run Scott Aerator's 3/4 HP DA-20 or Boilermaker specially equipped with a Franklin Electric three-phase submersible induction motor.

The Photon Drive provides power by converting high voltage, direct current from a solar array into alternating current to run a standard AC submersible motor. The controller provides fault detection, motor soft start, and speed control. The Photon Drive is designed to provide these features with the plug and play ease of installation similar to a single-phase control box.

The controller drives the pump and reduces output as necessary to protect the system components from damage, and only shuts down in extreme cases. Full operation is restored automatically whenever abnormal conditions subside.

Inspection

Before you begin, receive and inspect all components. Verify what was ordered and that no damage has occurred during transit.

Descriptions and Features

The Photon Drive system controller controls a Franklin Electric 4-inch three-phase motor driving a 4-inch submersible centrifugal pump powered by a DC solar array.

The Photon Drive continuously monitors system performance and incorporates a number of features for pump system protection. In the event of a fault, the Photon Drive will indicate the type of fault by a flashing red LED. (See Fault Codes and Troubleshooting on page 21 of the supplied manufacturer's manual).

The Photon Drive system is optimized for pumping under adverse input power conditions unique to solar arrays.

- Internal diagnostics will tolerate a lower input voltage.
- Whenever possible, the controller attempts to regulate the pump load in an optimized manner for maximum power transfer from the solar array. The controller construction is ruggedized for hostile environmental conditions.
- The case is constructed of heavy-gauge aluminum to resist rain and animal intrusion.
- The seals are designed for NEMA 4 (IEC rating IP66), (dust tight, withstands directed jets of water).
- For maximum protection against dust, there is no external cooling fan or other external moving parts.

Anytime working on or near the Photon™ Drive, or system:

- Turn OFF the external DC rated disconnect from the solar array to the Photon Drive.
- Securely cover the solar array with an opaque tarp.
- Wait a minimum of five minutes after removing power from the Photon Drive before servicing.
- Solar panels that have been exposed to full solar insulation for an extended period of time can achieve high temperatures and can be a potential source of burns to exposed skin if contacted. Use caution when working around solar arrays.

READ THESE INSTRUCTIONS COMPLETELY BEFORE INSTALLATION.

Note: During installation, if a conflict arises between this manual and local or national electrical codes, the applicable local or national electrical codes shall prevail.

- The longevity and performance of the Photon Drive package may be adversely affected by improper installation.
- The solar PV array structure, modules, and wiring harness must be properly assembled according to the manufacturer's installation instructions before installing the Photon Drive.
- The supplied 75 °C rated wire is sized for a maximum voltage drop of 3% per local electric codes.

Installation Preparation and Requirements

When installing the Photon™ Drive, be aware that:

- High voltage is present in the Photon™ Drive when powered on; use caution when live DC power is on.
- Do not allow any unauthorized persons near the solar array and connection sites while power is applied.
- A DC rated disconnect box is provided to disconnect the incoming DC power from the Photon™ Drive during installation and maintenance. Use a Volt Meter to confirm the absence of voltage in the line before proceeding with installation or maintenance.
- Appropriate consideration shall be given to sizing fuses to protect the wiring from the solar array's short circuit current (LSC). See local or national electrical codes for guidance.
- Keep all flammable materials away from the assembly site, including dry brush and vegetation.
- Keep the surrounding area clear of vegetation.
- Do not block airflow around the Photon Drive heat sink.
- Limit access of animals to the system.
- Protect wires from damage from wildlife and weathering by using conduit. For additional protection, bury the conduit in the ground.

Step 1: Prepare Installation Site

An example foundation drawing is shown below. While suitable for most locations, Scott Aerator cannot ensure that this design will be adequate for all installations. The installer is responsible for verifying that the foundation is adequate and meets all local code requirements for wind, snow and seismic loads.

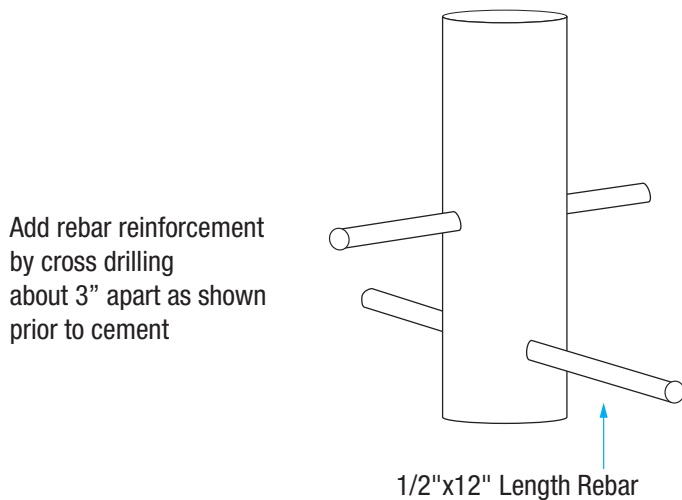
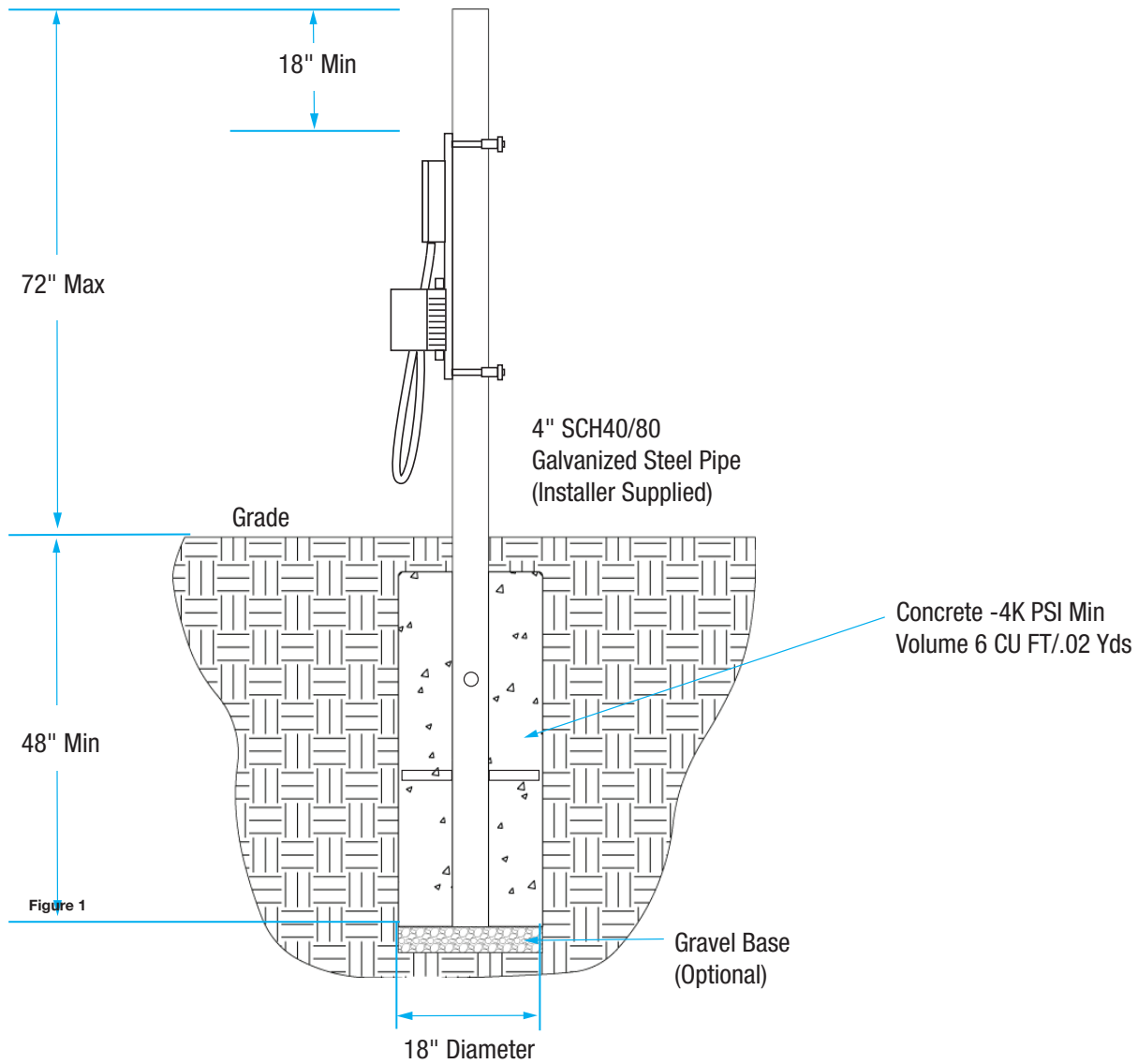

Step 2: Franklin Electric Photon™ Drive and DC Disconnect

Attach the DC Disconnect and Photon mounting frame to the pole using the included U-brackets a minimum of 18 in. (45.7 cm) beneath the array. See figure 1.

Attach the DC Disconnect to the frame with the included (2) 1/4" x 3/4" bolts, (2) flat washers, (2) lock washers, and (2) 1/4" nuts. See figure 4.

Attach the Photon box to the frame using (4) 1/4" x 3/4" bolts, (4) flat washers, (4) lock washers, and (4) 1/4" nuts. See figure 6.

Install Grounding Rod

Drive grounding rod into ground near the base of the solar array and secure #6 AWG solid copper grounding wire using supplied grounding clamp.

Properly secure the other end of the grounding wire to the dual grounding lug inside of the DC Disconnect. This will be the main equipment ground source. See figure 3.

Connect power supply from fountain or boilermaker

Secure unit in water. **An improperly secured fountain will rotate and may cause severe damage to the power cable or equipment.**

Installation instructions can be downloaded at scottaerator.com.

Route unit wiring back to Photon Controller.

Feed wire through the squeeze-tight connector supplied with the Photon Drive. Insert power cable sheathing flush with top of connector for a water tight fit. Secure motor power supply connections as shown in figure 5.

Connect PV Solar Array Power Cable

Feed the PV Solar power cable through supplied panel connector and attach positive and negative connections as shown in figure 4. Leave opposite end of cable unconnected until solar panels are covered and interconnected.

WARNING:

Do not connect PV Solar panels before all other connections are made and protective covers are in place

NOTE:

It is important that the Photon Drive be kept above potential snow and seasonal flood conditions.

WARNING:

Double check polarity to ensure positive and negative connections are in proper spots in DC Disconnect and Photon Controller

WARNING:

Do not use this system with any Fountain or Boilermaker that has not been equipped with a variable speed Franklin Electric three-phase induction motor

Figure 2

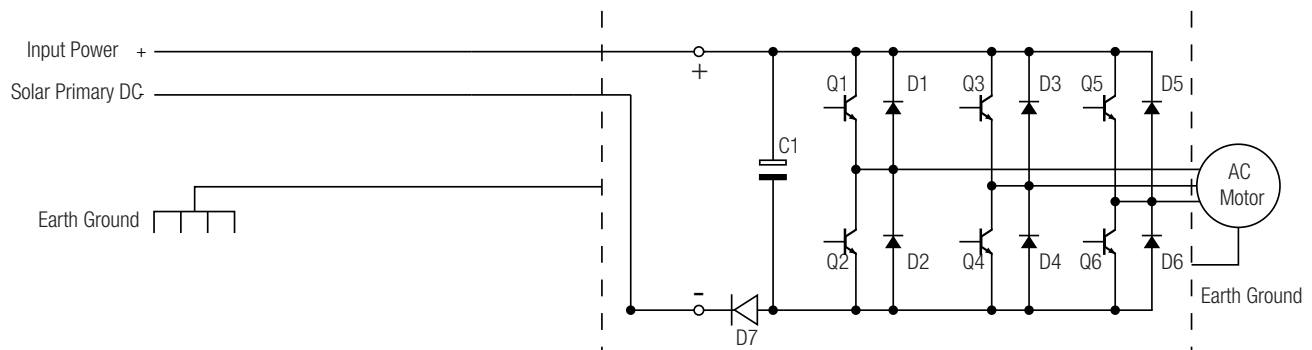

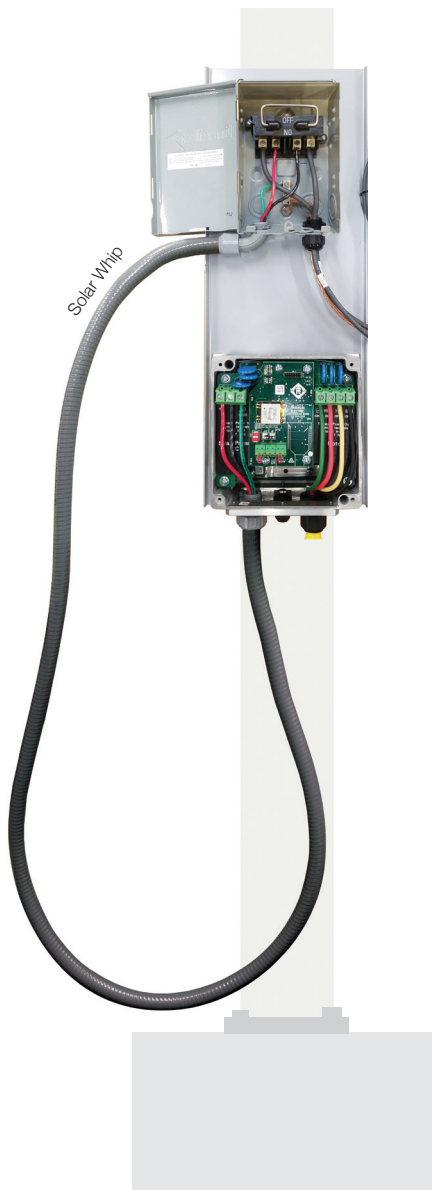

Figure 3

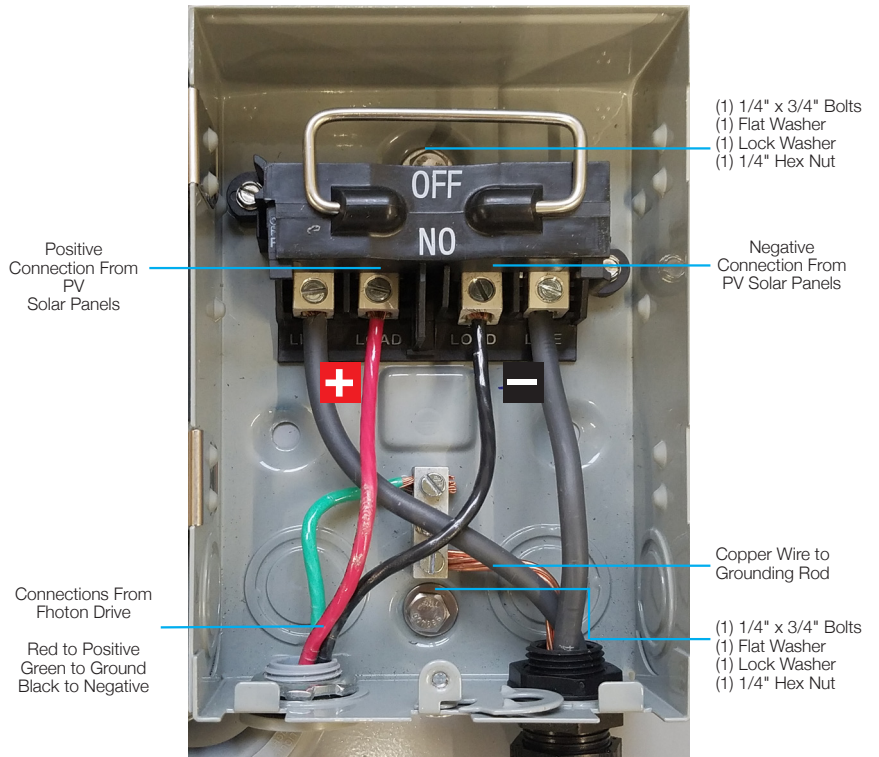

Figure 4

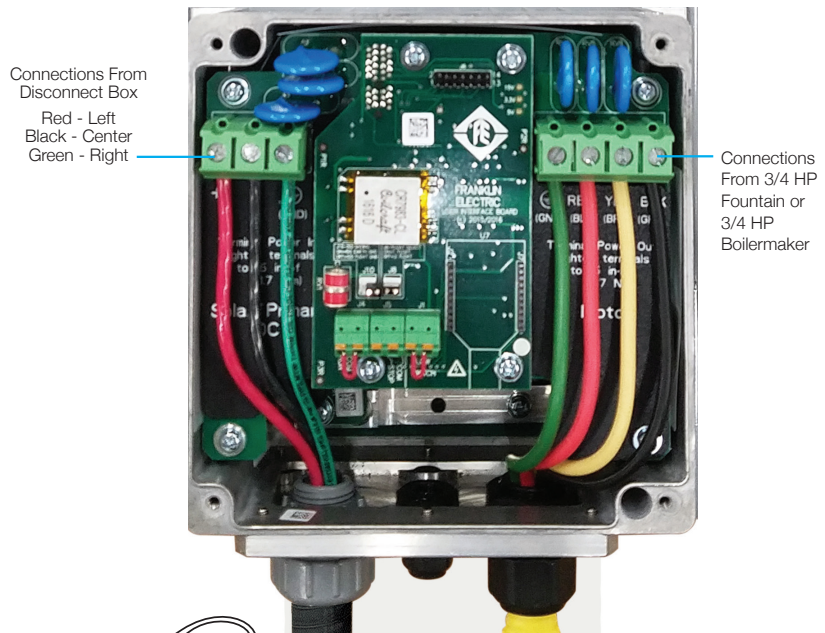

Figure 5

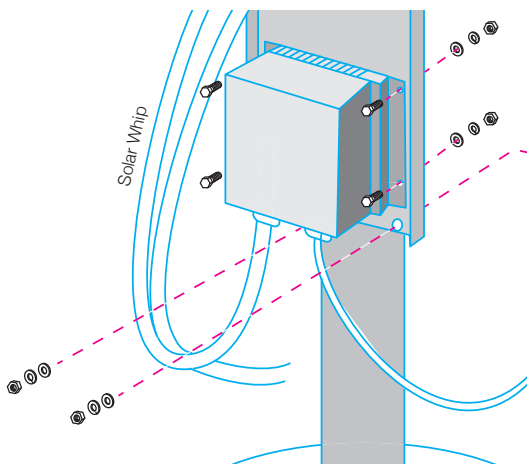

Figure 6

Step 3: Cross Bar Strong Back Assembly

Unpack the rail system from the pallet.

On a large flat surface (we used two tables spread apart) place two CROSS BARS horizontally approximately 41.5" from inside to inside. There are markings for positioning the MODULE RAILS later. These should be facing down. Figure 7

Attach the STRONG BACK over top and between the two CROSS BARS, aligning the downward facing outer mounting brackets to the inner markings on the MAIN RAILS (Figure 6). Secure each side with four 5/6" U-bolts, washers and serrated nuts. Figures 8 & 9

Top View - Cross Bar Markings for Strong Back



Bottom View - Cross Bar Markings for Module Rails



Figure 7

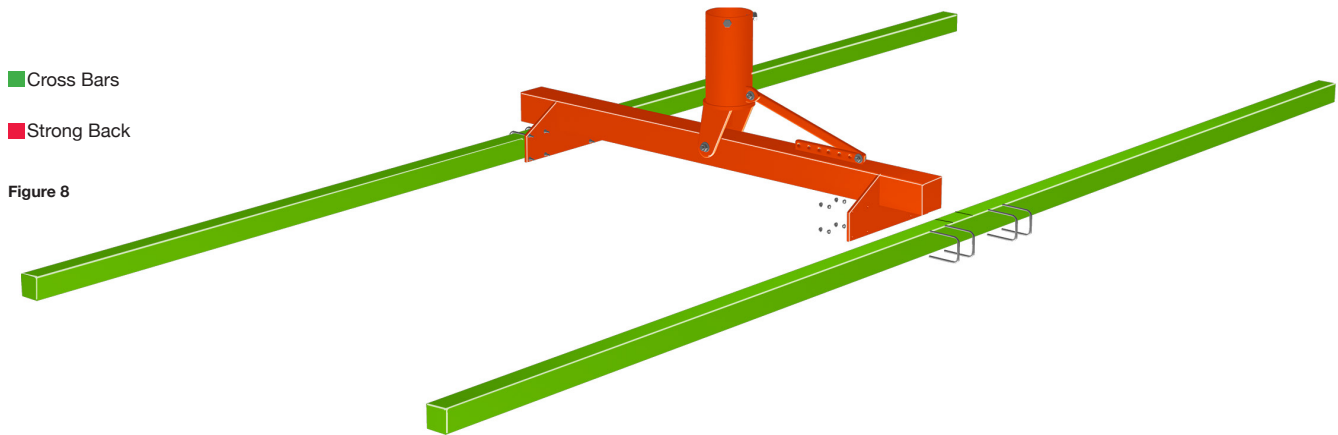
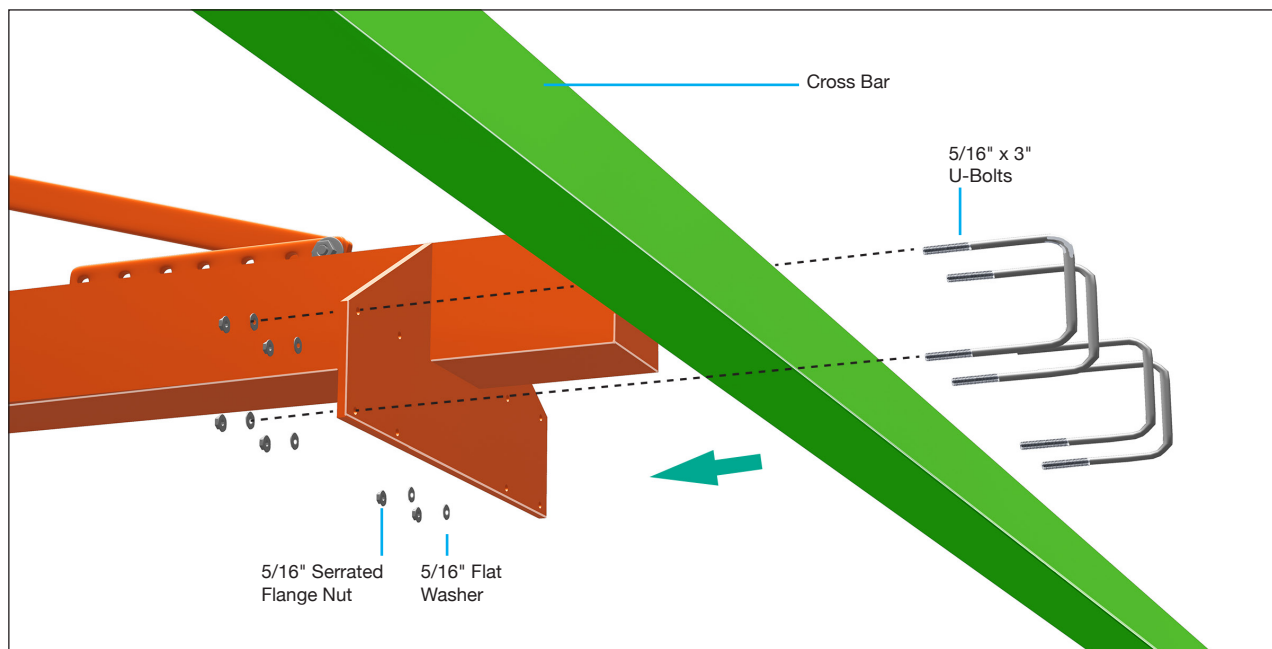

Figure 8

Figure 9



Step 4: Attaching The Module Rails

Flip over the CROSS BAR/STRONG BACK assembly so the STRONG BACK is on the under side. The MODULE RAIL markings on the CROSS BAR are facing up. (Figure 10)

Install (4) panel mounting rails where pre-marked on (2) main horizontal rails. Slide (4) 5/16" x 3" carriage bolts into downward facing slot on each MODULE RAIL (Figure 12). Align with markings, keeping 1 carriage bolt on each side of the CROSS BARS. Measure 17" from the outside CROSS BAR to the end of each MODULE RAIL (Figure 11). Secure with bracket and 5/16" serrated nuts. This is your solar array frame.

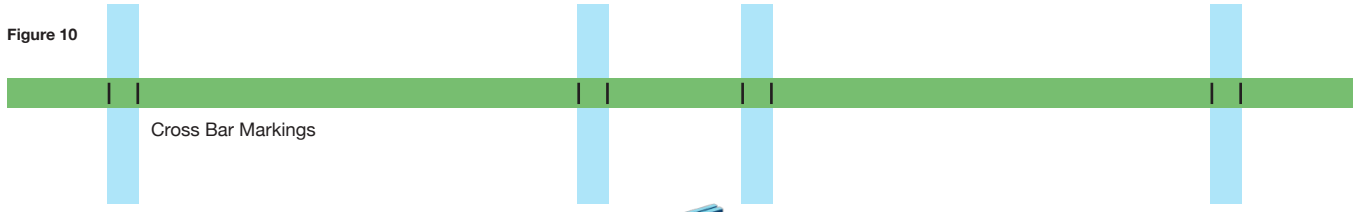

- Cross Bars
- Module Rails
- Strong Back

Figure 11

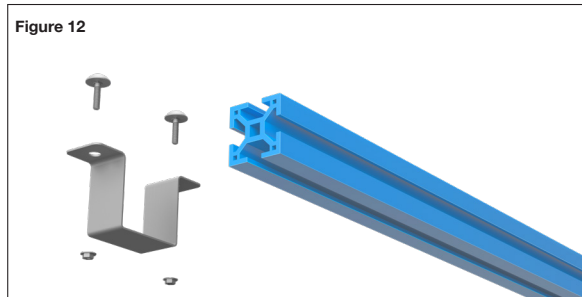
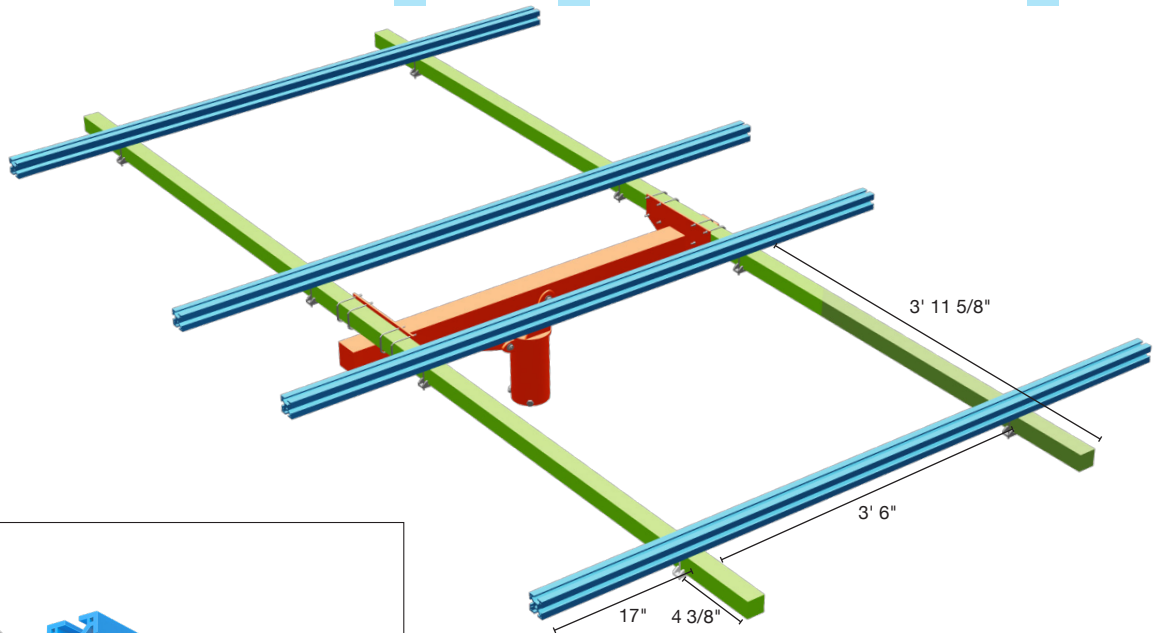
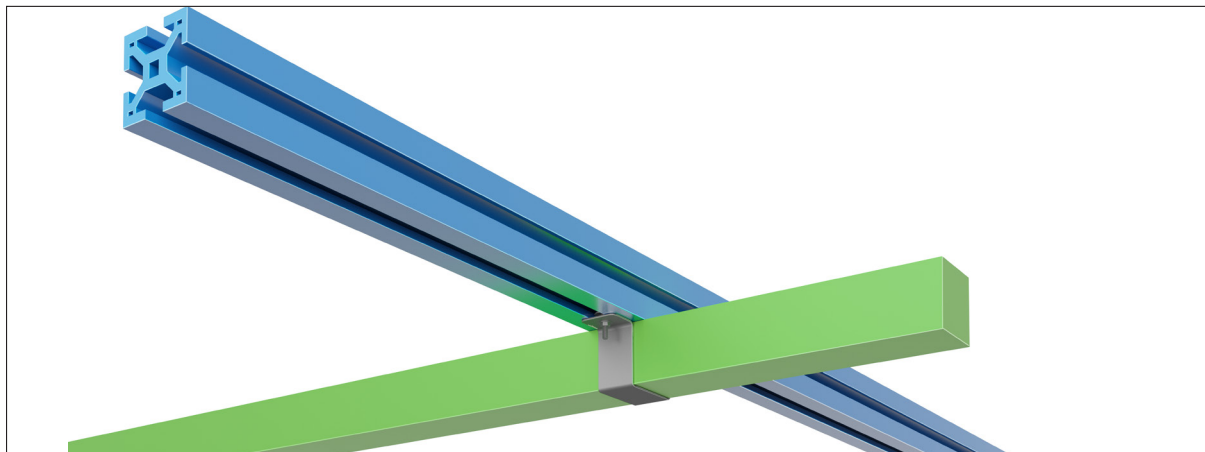

Figure 13



Step 5: Install the Solar Array Frame onto Properly Mounted 4" Pole

Before installing the Solar Array Frame, verify that the Mounting Pole is plumb to the ground and hasn't shifted or leaned while the concrete footing has cured.

The Mounting Sleeve slips on top of the Mounting Pole and has four 1/2" Set Bolts which are used to secure it to the Mounting Pole. (Figure 14)

Slip the Mounting Sleeve on top of Mounting Pole and slide it down until it rests/ bottoms out on top of Mounting Pole.

Rotate the Mounting Sleeve so the Support Bar Pivot Tab is pointing North and the Strongback Vertical Towers are leaning South.

Secure the Mounting Sleeve by tightening the four 1/2" Set Bolts. Torque each Set Bolt to 55-60 ft./lbs.

CAUTION:

Use care while working around the structure during the assembly. There could be components that create hazards or obstruct free movement causing serious bodily injury. Many are at head/eye level.

Figure 14

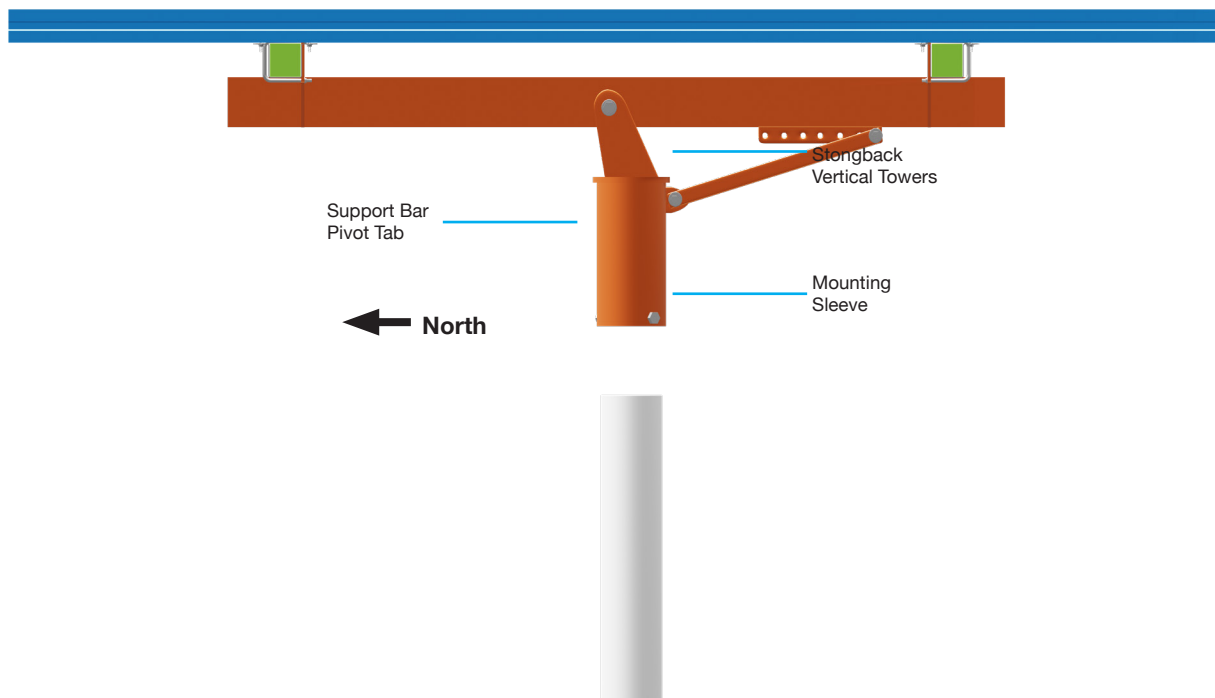

Step 6: Installing Solar Panels

Each solar panel is secured by (4) carriage bolts and (4) hex nuts.

Slide carriage bolts into track to line up when solar panel is 0.5" down from end of panel mounting rails. Figure 15

Install (4) solar panels with all 4 power converters on the back facing the middle of the array for easy panel interconnection. Figure 16

Secure the panels to the carriage bolts with the hex nuts. Figure 17

Properly series the 4 panel array. Cover solar panels with an opaque tarp and wait 5 minutes before making final connection from DC Disconnect solar leads to leads from solar panels. Double check wiring and connect the leads. Remove opaque tarp.

Have a qualified electrician check voltage at line side of disconnect. If operating properly, flip DC Disconnect to "on" and check for Photon operational status.

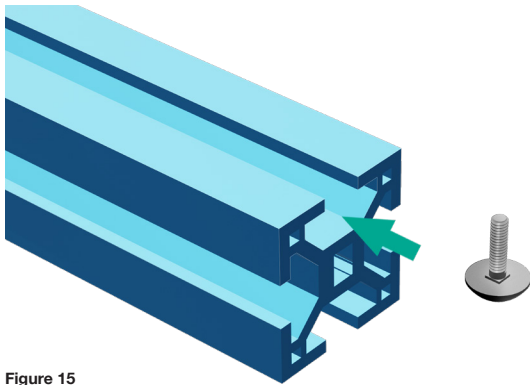

Figure 15

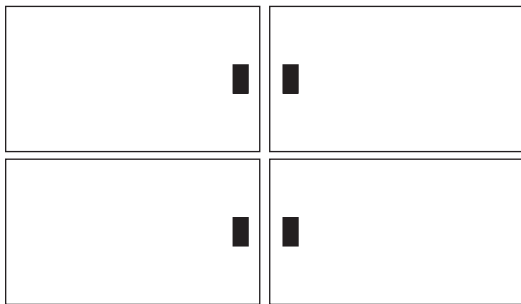

Figure 16

CAUTION:

This is a two person activity. PV Modules are heavy and unstable before they are fully secured to the Module Rails. PV Modules must be held in place by one person while the second person aligns and secures them to the Module Rails. Failure to do so could lead to serious personal injury and damaged components.

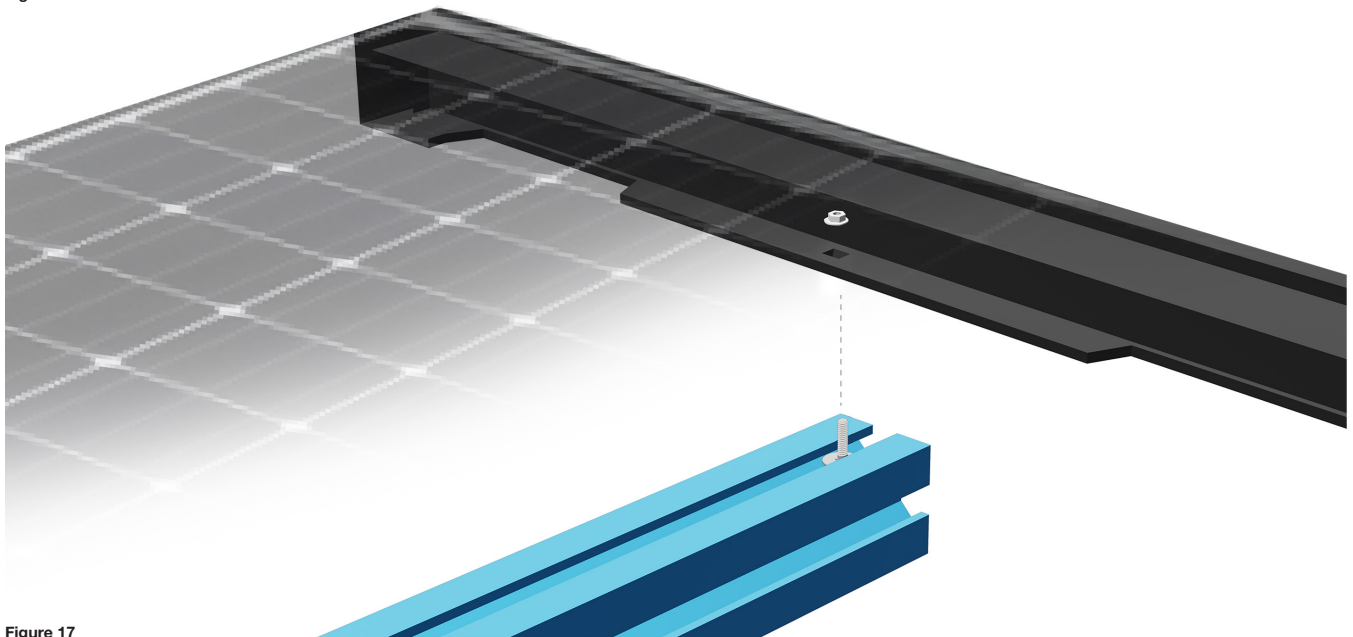

Figure 17

Step 7: Connect cables of PV Modules in series

Cover Solar Array with opaque tarp prior to interconnecting PV Module

Connect cables of PV Modules in series

Begin with upper left unit. Connect in series as shown in figure 18, making sure to seat each connector firmly. Connectors will click.

Caution: Be sure positive and negative connections are made correctly.

Connect Positive Cable from DC Disconnect to Positive (+) Cable coming from PV Module. Connect Negative (-) Cable to Negative Cable from PV Module.

Secure all loose cables to crossbars using zip ties.

WARNING:

Cover Solar Array with opaque tarp prior to interconnecting PV Module.

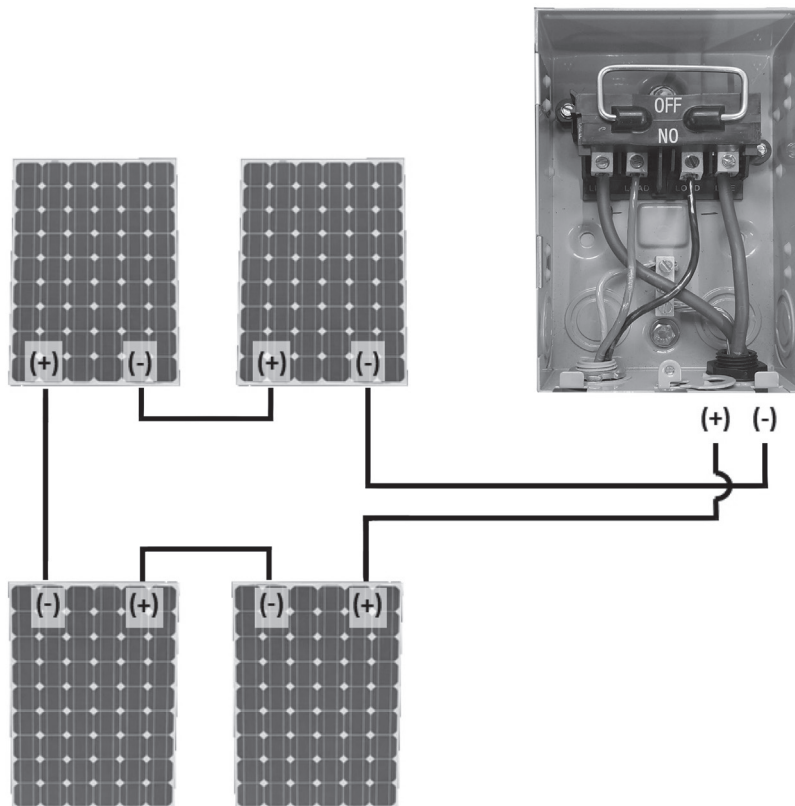
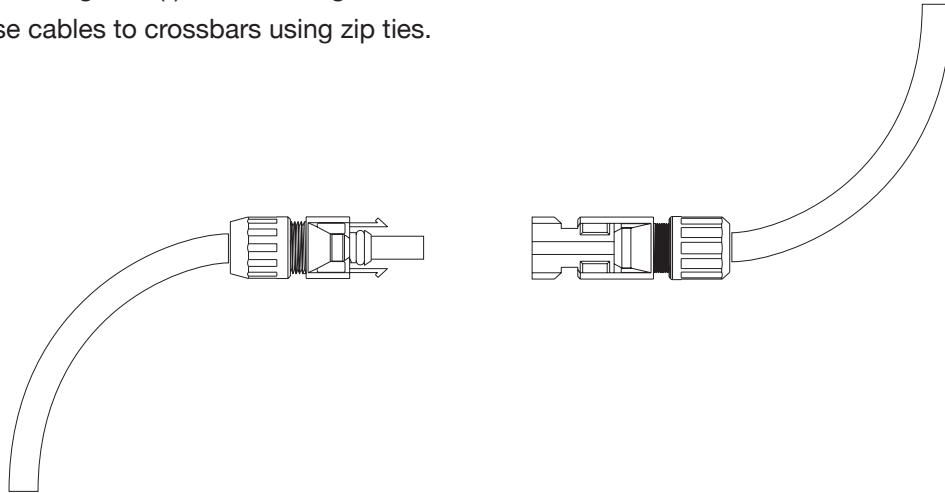

Figure 18

Step 8: Adjust the Tilt Angle of the Rack

Use great care in this procedure as it can be dangerous if the procedure is not completed as described with a minimum of two people.

To adjust the tilt angle, loosen the Pivot Bolt hardware and remove the Support Arm upper hardware attaching the Support Arm to the Strongback.

While one person holds the south edge of rack, the other loosens the Pivot Bolt and removes the upper 3/8" hardware attaching the Support Bar to the Strongback. (Figure 19)

Tilt the rack to the desired elevation angle (15°, 25°, 35°, 45°, 55° or 65°) and re-attach the Support Bar to the Strongback, placing the 3/8" hardware in the appropriate hole matching the desired elevation. Torque at 32-34 ft./lbs. (Figure 20)

After changing the tilt angle and tightening the Support Bar hardware, the Pivot Bolt must be re-tightened. The Mounting Sleeve Vertical Towers must be firmly clamped to the sides of the Strongback eliminating any gaps between the Vertical Towers and the Strongback. Torque to 125-150 ft./lbs. (Figure 21)

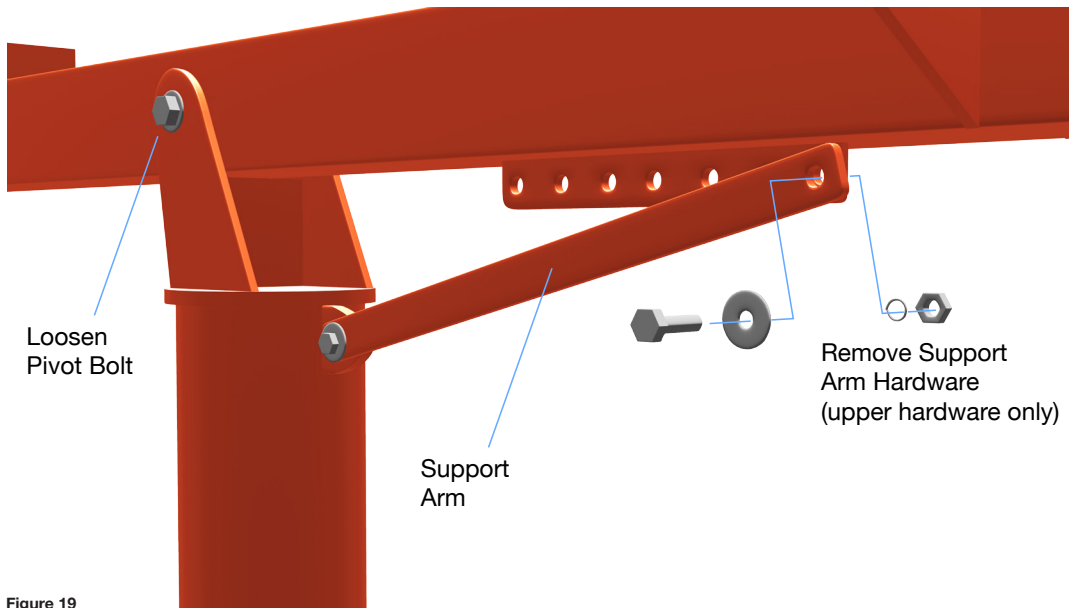

Figure 19

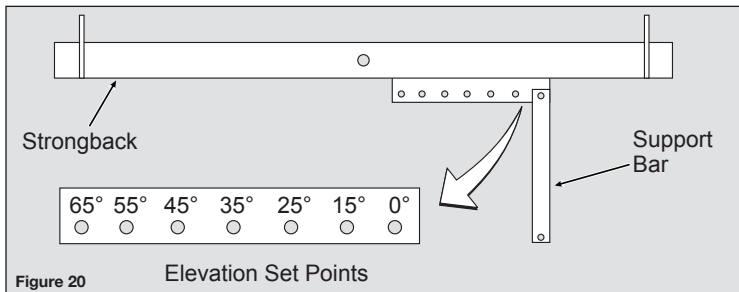

Figure 20

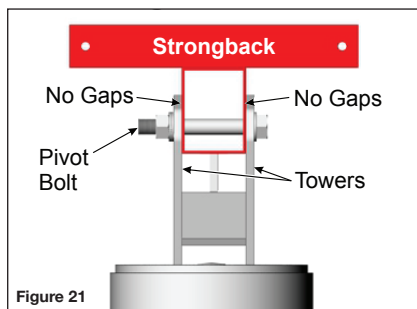

Figure 21

CAUTION:

Be certain to re-tighten all Module Rail and PV Module mounting hardware and torque to the specified values. Failure to do so could lead to structural failure, damaged components and/or serious personal injury.

CAUTION:

Do not attempt to remove the Pivot Bolt during tilt adjustments! Removal could lead to serious personal injury or death. Adjustments are made with the Pivot Bolt hardware loosened but in place.

CAUTION:

This is a two person activity. As the Pivot Bolt is loosened and the Support Bar hardware is removed, the rack is heavy and unstable. The rack must be held in place by one person while the second person loosens and removes the hardware and then re-installs/tightens the hardware back in place. Failure to do so could lead to serious personal injury and damaged components.

System Diagnostics

The Photon™ Drive comes equipped with an LED indicator to convey operational status to the user. When operating normally, the LED will indicate solid green (IDLE condition) or flashing green (RUNNING condition). While in the RUNNING condition, the flash sequence count indicates rotor speed. A flash sequence is defined as follows: LED On for 0.5 seconds, LED Off of 0.5 seconds. Each sequence is separated by a 2 second Off time to give a clear visual indication between flash sequences. Flash sequences and cycles apply to both the red and green LED.

As an example, a 4 flash sequence of the green LED indicates an operating speed between 35 and 45 Hz. (See Table 1. Green LED Flash Sequence (RUNNING Condition))

Flash Sequence Count	Rotor Speed (Hz)
1	< 15
2	15-25
3	25-35
4	35-45
5	45-55
6	55-65

Table 1. Green LED Flash Sequence
(RUNNING Condition)

The Photon Drive continuously monitors system performance and can detect a variety of abnormal conditions. In many cases, the controller will compensate as needed to maintain continuous system operation; however, if a high risk of equipment damage exists, the controller will protect the system and indicate the fault condition via a flashing red LED. If possible, the controller will try to restart itself when the fault condition subsides (see Troubleshooting section page 21 of the supplied manufacturers guide for a list of Fault Codes and correction actions). Refer to the Photon™ manual for details on conditions in which a fault will occur.

The Scott Aerator Warranty

All Scott Aerator motors are unconditionally warranted for five years against motor defects in materials or workmanship, under normal operating conditions. All other product components are warranted for one year from date of purchase. Scott Aerator will repair or replace failed parts under warranty when the defective unit is returned to the factory, shipping prepaid, and factory inspection establishes that the part was defective. The unit must be returned to the factory prior to shipment of replacement parts. All parts replaced under this warranty will be returned with shipping prepaid. Scott Aerator will not be liable for consequential damage nor for any costs associated with removal or attempts to repair components in the field.



13245 Barry Street, Holland, MI 49424
scottaerator.com
information@scottaerator.com
800-WATER-45 (800-928-3745)
(616) 392-8882

