

INSTALLATION INSTRUCTIONS

DeerValley®

Workstation Farmhouse Kitchen Sink

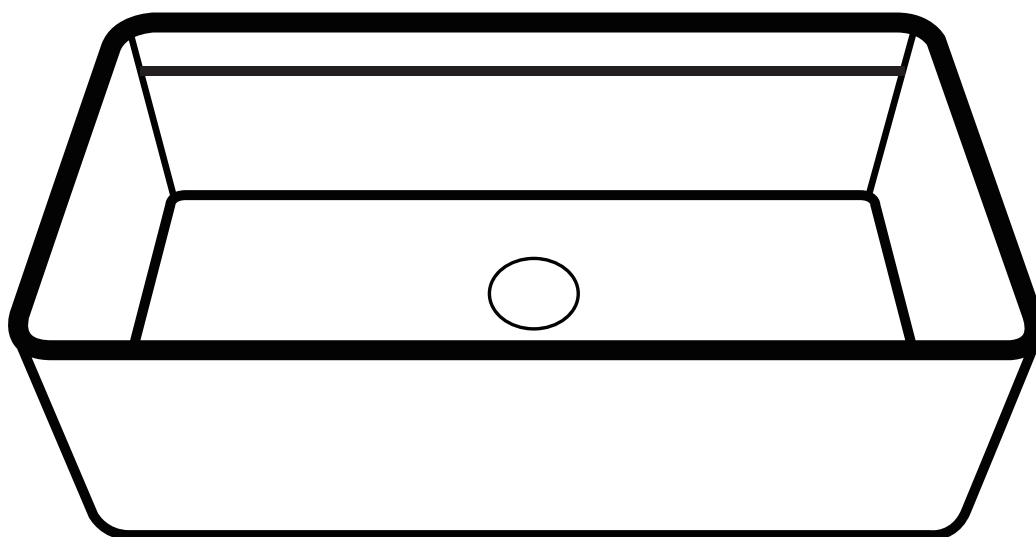



Prior to Installation:

- Inspect kitchen sink to ensure no damages have occurred while in shipping.
- Observe all plumbing and building codes in accordance with your state and local requirements.
- Additional floor and wall preparations may be necessary to avoid damage to the product.
- Make sure to purchase the correct cabinet for your farmhouse sink.
- Farmhouse base cabinets should be 3" larger than the actual size of the sink.
- Installation with laminate countertop not recommended.
- All dimensions are nominal! Be sure to measure your cabinet to installation.

General Recommendations:

Please read installation and maintenance instructions thoroughly before installing the kitchen sink.
Be sure to use proper tools and always wear proper personal safety accessories for your protection.

**If you have any questions or concerns
please contact us:**

(+1) 312-626-9466
service@deervalleybath.com

1. INSTALLATION OPTIONS

- Farmhouse apron installation is recommended; avoid flushmount, undermount, overmount, or drop-in options.
- Ensure ample room for faucet and backsplash installations.

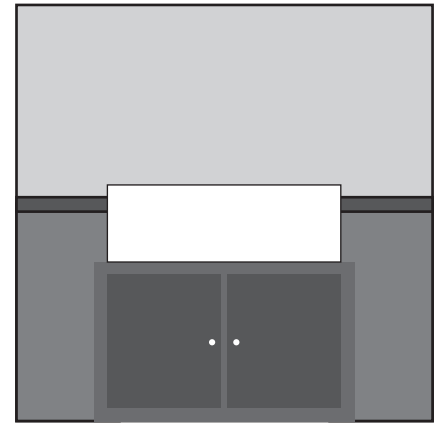
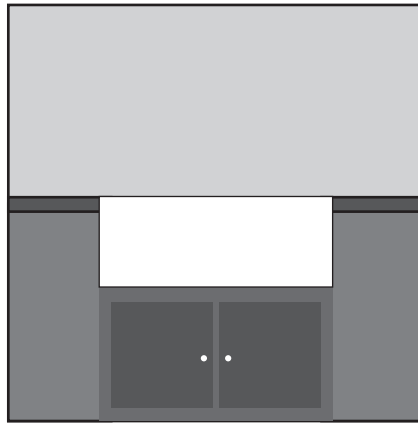
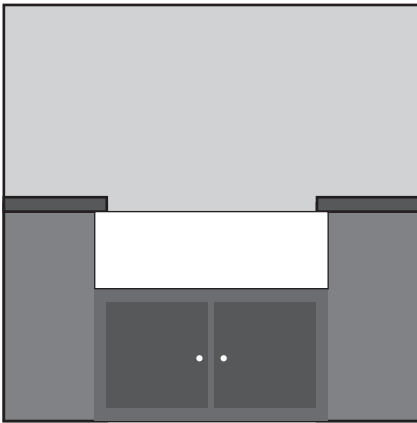

2. INSTRUCTIONS

- Unpack and inspect the sink for shipping damages. Ensure all required pieces are present. If damages are found, do not proceed with installation; please contact us.
- Due to the manufacturing process, each sink will vary slightly dimensionally. Farmhouse sink may require custom cabinetry. We recommend consulting an experienced cabinet maker for assistance. Providing the cabinet maker with the actual sink to be installed will ensure a custom fit.
- Please use assistance when lifting the sink in order to avoid personal injury.
- We recommend consulting a professional if you are unfamiliar with installing kitchen fixtures and plumbing. DeerValley accepts no liability for any damages to the floor, walls, plumbing or personal injury during installation.

SUGGESTED TOOLS AND MATERIALS



Framing Square



Safety Glasses



Pencil



Tape Measure



Level



Thread Sealant



Wood Shims



Basin Wrench



Drill

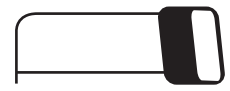

Hacksaw

- Sealant - We recommend the use of a stone, marble and granite silicone caulk or a general purpose silicone sealant.
- Installation tools are not provided; please prepare them yourself.

3. PREPARE THE CABINET

- Farmhouse sink may require custom cabinetry. We recommend consulting an experienced cabinet maker for assistance. Providing the cabinet maker with the actual sink that is to be installed will ensure a custom fit.
- Allow clearance for the water supply lines, drains and a garbage disposal, if applicable. Build a support frame or install support bars from front to back along the inner sides of the cabinet. The frame must support the weight of the sink and all attachments.
- The support frame should be positioned so that when installed, the sink is in line and level with the top of the cabinet.

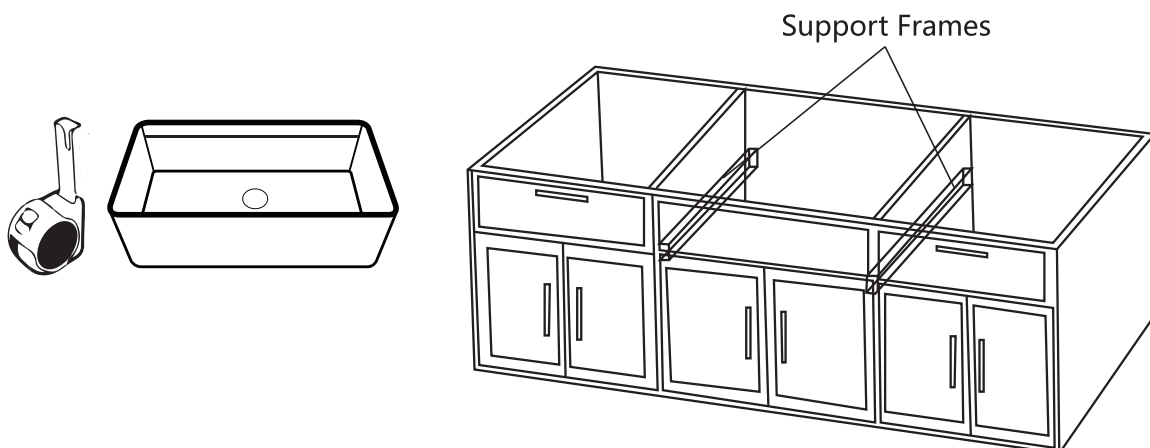

4. TEMPLATE AND CUTOUT

- No template is provided since each sink will vary dimensionally. After centering the sink, trace the outline of the sink on the counter-top with a pencil to use as a guide for the cutout. Remember to allow clearance for any faucets and/or backsplashes. Cut the counter-top accordingly.

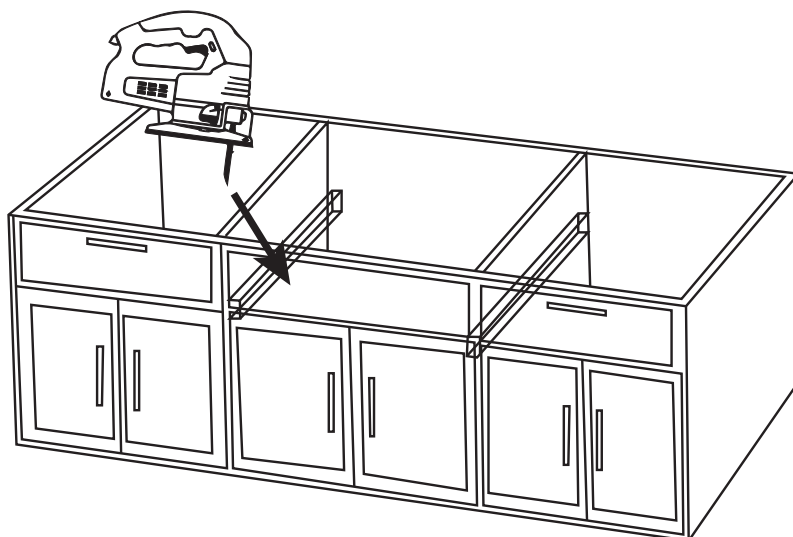

5. FINAL PLACEMENT

- Test fit the sink in the opening that was created in the previous steps. The entire weight of the sink should be supported by the support frame. Verify that the sink is in line and level with the top of the cabinet. Use shims, if needed, to level the sink.
- Set the sink and apply your sealant to fill in any gaps below the sink front, and between the sink and counter-top. Hold the sink in place to secure. Place the counter-top onto the sink and remove any excess sealant from all surfaces.

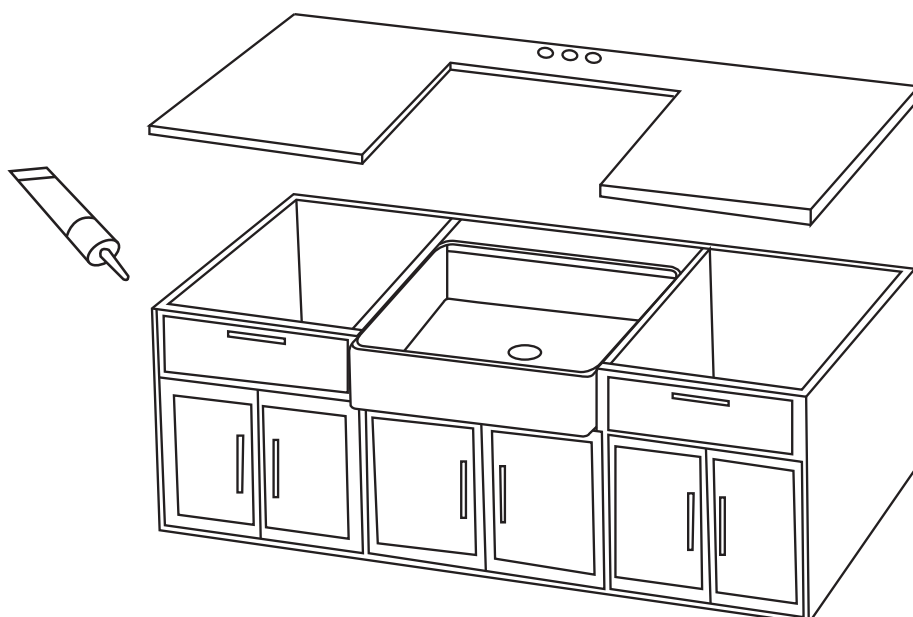

LIMITED WARRANTY COVERAGE

1 YEAR LIMITED WARRANTY

DeerValley products are made with quality materials and excellent craftsmanship to provide the customers a long-lasting product. In the case of any defects in materials or craftsmanship under regular use were inspected in the first one year of delivery, DeerValley will provide replacement parts at no charge, or at its option, replace any product or part of the product that is deemed defective, under normal installation, use, service and maintenance. This warranty applies only to the original purchaser. Proof of purchase will be required in the case of a claim. **SCRATCHES ARE NOT COVERED UNDER WARRANTY.**

The manufacturer warrants this product to be free of manufacture defects during the above mentioned warranty time. Please keep a copy of the original invoice as proof of purchase.

DeerValley will, as its option, (1) repair or replace the defective part(s) or product(s) at no charge; (2) issue a refund of the original purchase price of the product(s) (Valid within 30 days from the date of delivery); or (3) issue a credit to be applied toward the purchase of a new DeerValley product shipping/delivery charges may apply and are in DeerValley sole discretion.

DeerValley recommends the installations to be made by a licensed, professional plumber. DeerValley will not be held responsible for any damage or product failure due to improper installation, misuse, or failure to use a licensed professional. DeerValley is not responsible for any removal or installation cost.

This limited warranty shall not apply to goods which have been subject to accident, negligence, improper installation, product abuse, product misuse, or use of cleaners containing abrasives, alcohol or other organic solvents, whether performed by a contractor, service company, or yourself, are excluded from this warranty.

DeerValley responsibility under this limited warranty is limited to only to replacement parts and no other costs. DeerValley will not be responsible for labor charges and/or damage incurred by installation, repair or replacement, nor for any indirect incidental or consequential damages, losses, injury or costs of any nature relating to this product Except as provided by law, this limited warranty is in lieu of and excludes all other warranties, conditions, and guarantees, whether expressed or implied, statutory or otherwise, including without restriction those merchantability of fitness for use.

RESPONSIBILITIES OF OTHERS

Inspecting the unit prior to installation is the responsibility of the installer or building contractor who acts on behalf of the user. They are responsible for ensuring the unit is free of defect or damage.

Notices are placed on and in the unit and on the shipping carton advising the installer of this responsibility.

In the event of a problem, the unit must not be installed. DeerValley is not responsible for failures or damage that could have been discovered, repaired, or avoided by proper inspection and testing prior to installation.

Damage occurring in transit is the responsibility of the carrier. The user or installer **MUST** open the crate and inspect the unit for damage when it is delivered. If damage is discovered, it must be reported immediately to the seller and the carrier in writing, and an inspection requested. Failure of the carrier to respond should be reported to the seller and the carrier. Your freight claims should be filed promptly thereafter.

LIMITATIONS AND EXCLUSIONS

This warranty does not cover instances of negligence, misuse, abuse, improper installation, carelessness, accident, hard water or mineral deposits, exposure to corrosive materials, misapplication, damages caused by improper maintenance, alteration of the product, or failure to follow care or installation instructions enclosed with your product. The warranty becomes invalid if the DeerValley product undergoes any alterations or if attempts are made to carry out repairs using unauthorized accessories or parts from DeerValley.

DeerValley will not be liable for loss of use of the DeerValley products, inconvenience, or any other incidental or consequential costs, expense or damages. Please note that some states do not allow the exclusion or limitation of incidental damages.

DISCLAIMER

Except as expressly provided, there shall be no warranty or obligation, express or implied, oral or statutory. No dealer or other person has the authority to make any warranties or representations concerning DeerValley or its products. In no event shall DeerValley be held responsible for any such warranties or representations.

WARRANTY SERVICE

NOTE: When requesting warranty, be sure to have the following:

- Copy of original invoice
- Date of installation
- Description and pictures of defect
- Model number or description of model

To obtain warranty service and replacement part, please contact DeerValley Customer Service. DeerValley will determine whether to repair or replace your product, issue a refund, or issue a credit.