

INSTALLATION INSTRUCTIONS

DeerValley®

One-Piece Toilet

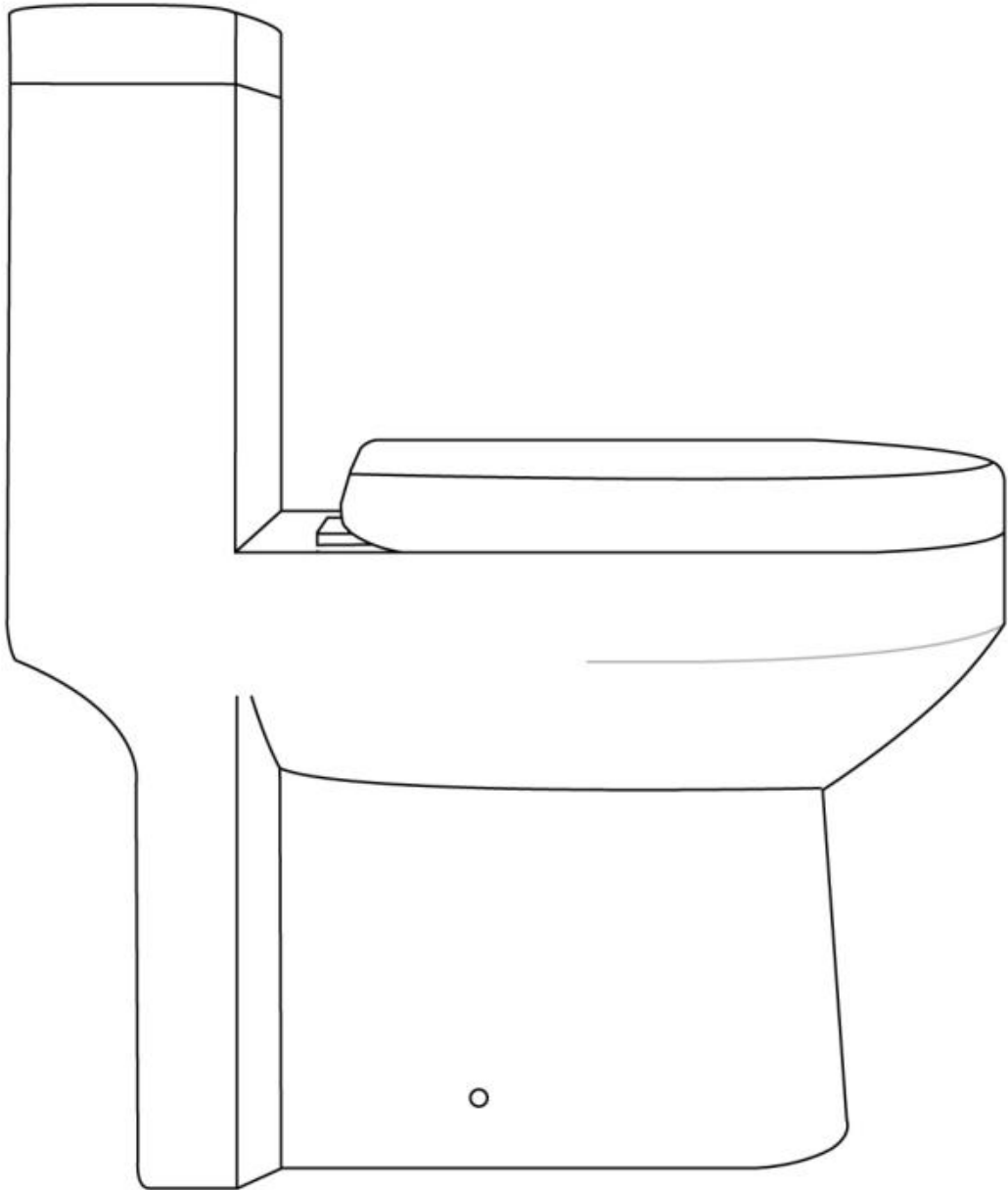



Prior to Installation:

- Inspect toilet to ensure no damages have occurred while in shipping.
- Observe all plumbing and building codes in accordance with your state and local requirements.
- Remove old toilet.
- Make sure mounting surface is CLEAN and LEVEL.

General Recommendations:

Please read installation and maintenance instructions thoroughly before installing the toilet.

Be sure to use proper tools and always wear proper personal safety accessories for your protection.

**If you have any questions or concerns
please contact us:**

312-626-9466

support@deervalleybath.com

SUGGESTED TOOLS AND MATERIALS

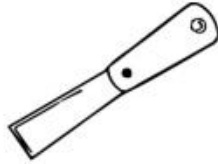

Putty Knife



Wrench



Tape Measure



Level



Water Supply Kit



Cross Screwdriver

PARTS LIST

- DeerValley One-Piece Toilet
- Wax Ring/Gasket
- Bolts Kit

The step-by-step guidelines in the installation instructions are a general reference for installing a DeerValley One-Piece Toilet. Should there be any discrepancies, DeerValley cannot be held liable. It is recommended to install all DeerValley products by hiring a licensed professional.



1. Read the complete instruction manual before beginning installation.



2. Confirm that your model will fit in intended location and plumbing fixtures are located where legally required before beginning installation.



3. Not all drawings on this manual are drawn to scale. Please refer to the model chart.

4. Two people are recommended to install and move this product.

5. Product is FRAGILE! To avoid breakage and possible injury handle with care.

NOTE: Specialized tools may be necessary to install DeerValley One-Piece Toilet, plumbing not included.

1. Remove Old Toilet

- Turn off the water supply.
- Flush the toilet to empty the tank. Remove any water left in the tank or bowl.
- Disconnect the supply line from the tank.
- Remove decorative caps. Unscrew nuts that attach the toilet to the floor.
- Remove toilet.
- Make sure the water supply valve is shut off before installation.
- Remove old closet bolts from closet flange. Clean any old wax, putty, etc. from base area.

IMPORTANT NOTE REGARDING WATER SUPPLY:

Before installation ensure that the shut-off valve is greater than 7/16" from the center of the drain to the center of the shut-off valve on either side.

NOTE: This is a true 12" rough-in toilet from finished wall to center of the drain (no less than 12"). Baseboard thickness may reduce rough-in dimension.

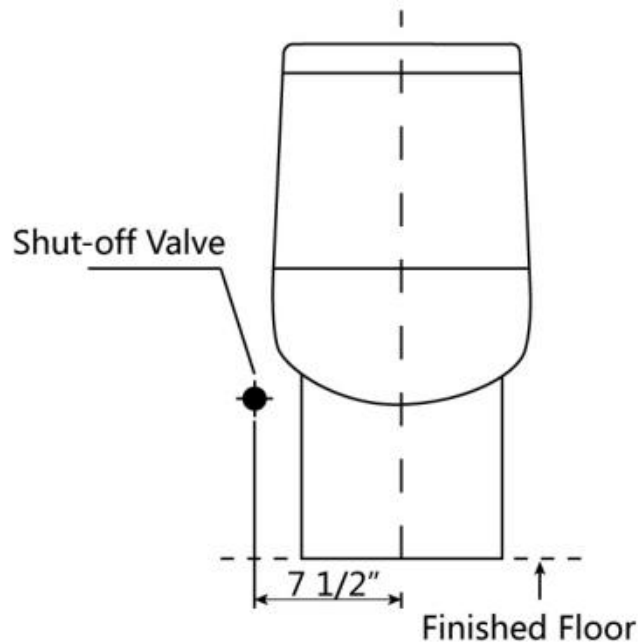

NOTE: Drawings may not exactly define contour of the product.

2. Install the Floor Bolts and L-bar

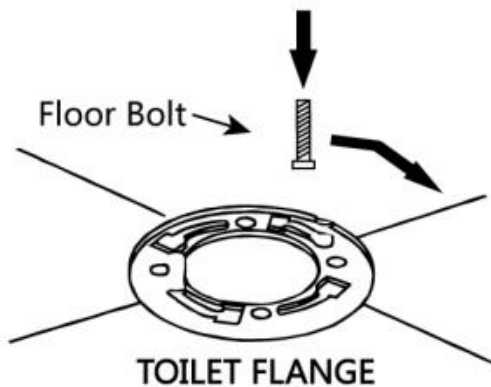

Note: The two screws and the center of the flange must be in a straight line.

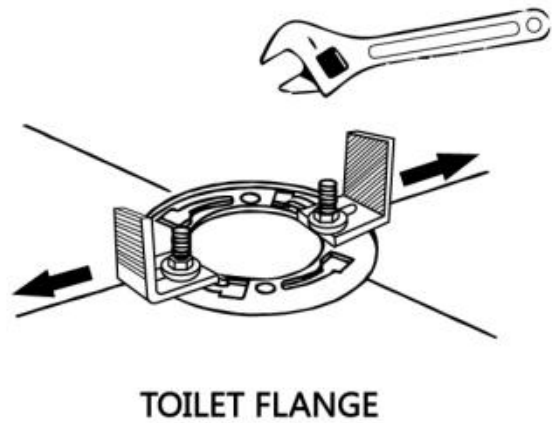
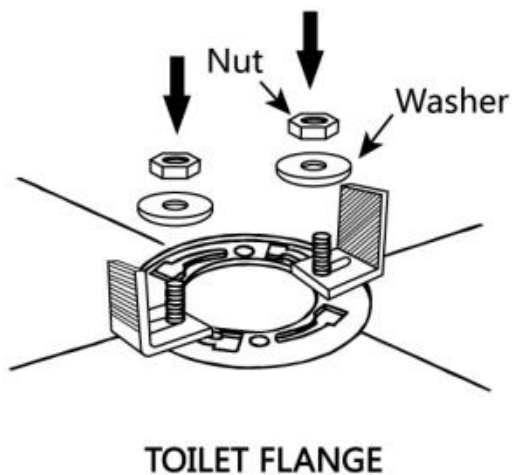

Pull the L-bar to max distance, then tighten the nuts.

3. Install Wax Ring

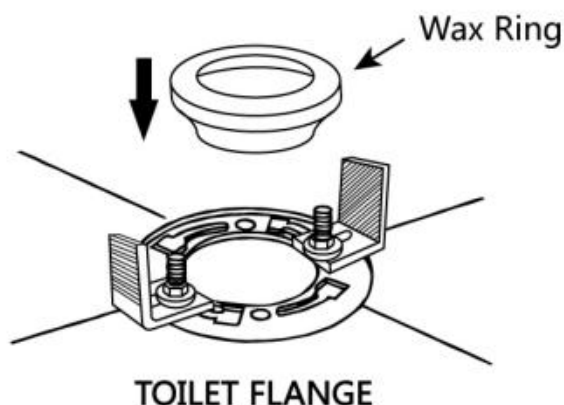

Install the wax ring and adjust the L-bar and fasten it. Please make sure the L-bar in a straight line.

NOTE: Drawings may not exactly define contour of the product.

4. Connect Supply Line

- Attach flexible water supply line to the inlet of the fill valve and hand tighten only. At this point, DO NOT connect to the water shut-off valve. Choose 1/2" or 7/8" supply line inlet hole according to your supply line size. The supply line inlet hose has an adapter, please screw off the adapter or not according to your supply line size.

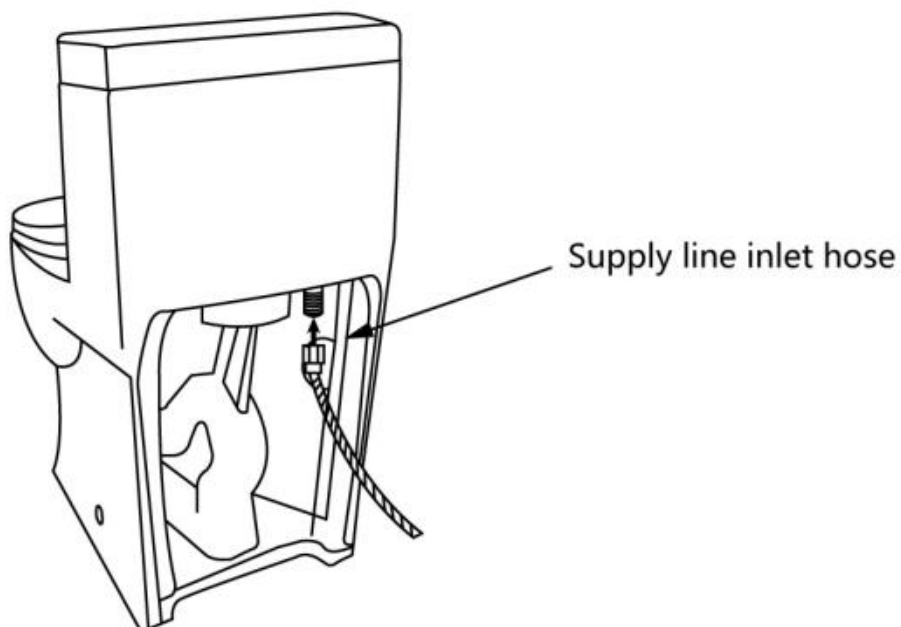

5. Install the Toilet

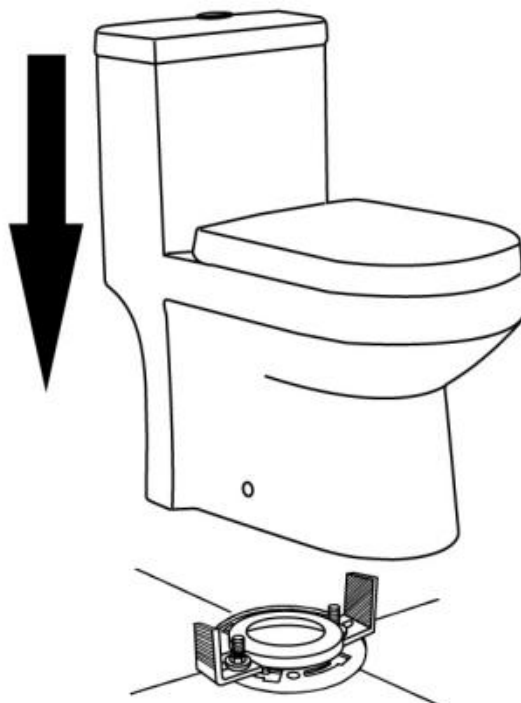

Put the toilet on the flange and push it tight.

NOTE: Drawings may not exactly define contour of the product.

6. Install Cover Cap

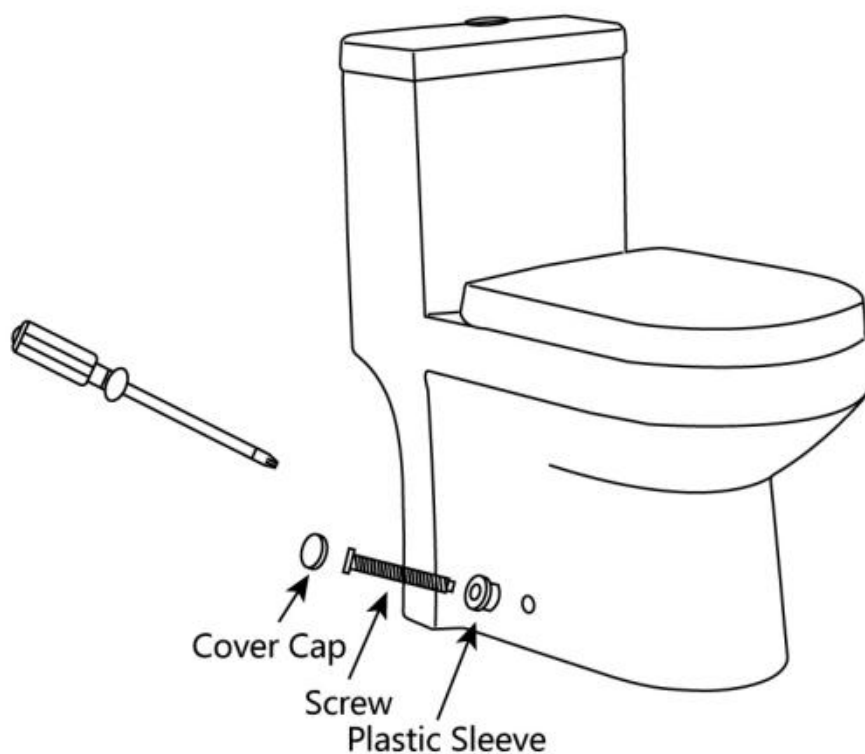

Install the screws from two small holes with Cross Screwdriver.

7. Tighten Supply Line to the Shut-off Valve

- Connect the flexible water supply line (not included) to the shut-off valve. Tighten coupling nut securely.

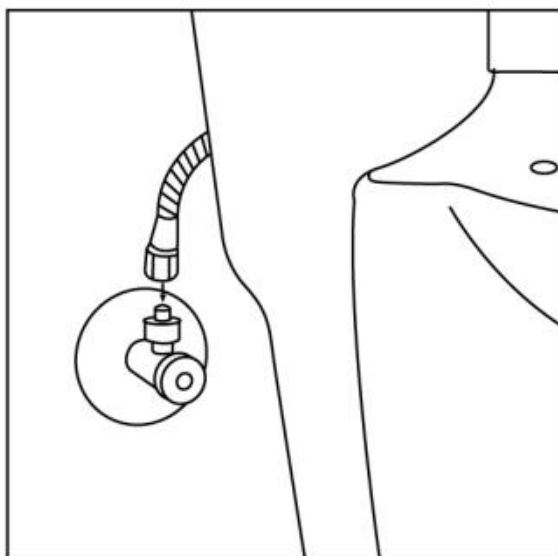

NOTE: Drawings may not exactly define contour of the product.

LIMITED WARRANTY COVERAGE

1 YEAR TOILET BOWL & TANK

DeerValley warrants its toilet bowl & Tank against fading /staining of the glaze as a result of a defect in materials and workmanship for a period of one (1) year from the purchase date. **SCRATCHES ARE NOT COVERED UNDER WARRANTY.**

1 YEAR TOILET SEAT • 1 YEAR FILL VALVE & FLUSH VALVE • 1 YEAR PLUMBING PARTS

DeerValley warrants factory installed plumbing parts and fittings, and electrical components to be free from defect in materials and workmanship for a period of one (1) year from the purchase date.

The manufacturer warrants this product to be free of manufacture defects during the above mentioned warranty time. Please keep a copy of the original invoice as proof of purchase.

DeerValley will, as its option,(1) repair or replace the defective part(s) or product(s) at no charge; (2) issue a refund of the original purchase price of the product(s) (Valid within 30 days from the date of purchase); or (3) issue a credit to be applied toward the purchase of a new DeerValley product Shipping /delivery charges may apply and are in DeerValley sole discretion.

DeerValley products must be installed by a fully insured and licensed plumber only. Installation of any our product by anyone other than fully insured and licensed plumber shall void limited warranty.

This limited warranty shall not apply to goods which have been subject to accident, negligence, improper installation, product abuse, product misuse, or use of cleaners containing abrasives, alcohol or other organic solvents, whether performed by a contractor, service company, or yourself, are excluded from this warranty.

DeerValley responsibility under this limited warranty is limited to only to replacement parts and no other costs. DeerValley will not be responsible for labor charges and/or damage incurred by installation, repair or replacement, nor for any indirect incidental or consequential damages, losses, injury or costs of any nature relating to this product Except as provided by law, this limited warranty is in lieu of and excludes all other warranties, conditions, and guarantees, whether expressed or implied, statutory or otherwise, including without restriction those merchantability of fitness for use.

RESPONSIBILITIES OF OTHERS

Inspecting the unit prior to installation is the responsibility of the installer or building contractor who acts on behalf of the user. They are responsible for ensuring the unit is free of defect or damage. Notices are placed on and in the unit and on the shipping carton advising the installer of this responsibility. In the event of a problem, the unit must not be installed. DeerValley is not responsible for failures or damage that could have been discovered, repaired, or avoided by proper inspection and testing prior to installation.

Damage occurring in transit is the responsibility of the carrier. The user or installer **MUST** open the crate and inspect the unit for damage when it is delivered. If damage is discovered, it must be reported immediately to the seller and the carrier in writing, and an inspection requested. Failure of the carrier to respond should be reported to the seller and the carrier. Your freight claims should be filed promptly thereafter.

LIMITATIONS AND EXCLUSIONS

This warranty does not cover any claim arising from abuse, misuse, negligence, accident, improper installation or operations on the part of the purchaser. This warranty is void if the DeerValley is subject to alteration, or if repairs are attempted by anyone other than an authorized agent of DeerValley. This warranty does not extend to plumbing or components installed by dealers, installers or by any party other DeerValley.

DeerValley will not be liable for loss of use of the DeerValley inconvenience, or any other incidental or consequential costs, expense or damages. Please note that some states do not allow the exclusion or limitation of incidental damages.

DISCLAIMER

Except as expressly provided, there shall be no warranty or obligation, express or implied, oral or statutory. No dealer or other person has the authority to make any warranties or representations concerning DeerValley or its products. In no event shall DeerValley be held responsible for any such warranties or representations.

WARRANTY SERVICE

NOTE: When requesting warranty, be sure to have the following:

- Copy of original invoice
- Date of installation
- Description and pictures of defect
- Model number or description of model

To obtain warranty service and replacement part, please contact DeerValley Customer Service. DeerValley will determine whether to repair or replace your product, issue a refund, or issue a credit.