

29 Doris

FMM 52

As seen in *The Farmer's Wife 1930s Sampler Quilt* book by Laurie Aaron Hird

From MARTI MICHELL Perfect Patchwork Templates Conversion Chart

For personal use in conjunction with the book and these From MARTI MICHELL Tools: Perfect Patchwork Template Set B #8252; Set D #8254. Optional: Multi-Size Peaky & Spike #8289



Doris Template	29A	29B	29C	29D, E	29F
is the same as FMM Set	D-28	Spike, 2" finished D-22 modified	D-29	Peaky, 2" finished D-23 modified	B-13

Observe grainline arrows on templates when cutting.

Cutting

Work on a small rotating mat if you have one.

- Place 2½" x 8" strips of fabrics 1 and 3 right sides together and cut 4 pairs of B-13 triangles. Do not separate; they are ready for chain piecing.

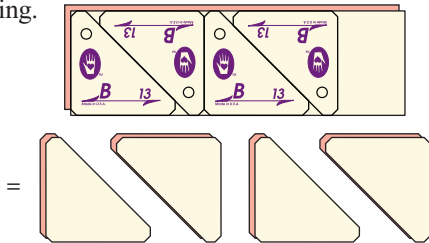

- Both the Peaky and Spike triangles are cut from strips cut on the crosswise grain. Cut out the paper patterns and tape them under D templates 22 and 23 so the long edges are aligned but use the acrylic template to rotary cut the triangle corners. Our engineered corners for Peaky require a strip ⅛" wider than you'd expect. (See page 2 for a full size explanation.) Don't worry—the pieces will fit together. Peaky triangles need to be cut with fabrics right sides together to get mirror image pieces.

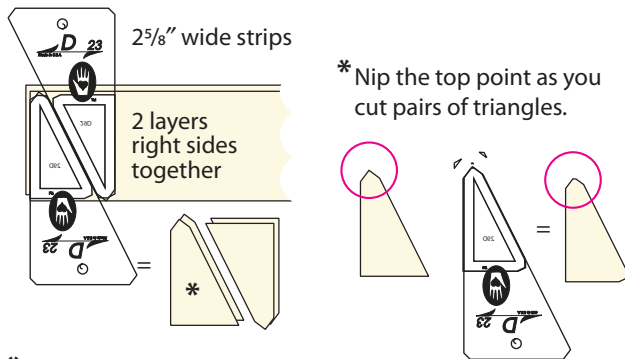

* Reposition the template and nip the remaining points before separating the pairs of triangles.

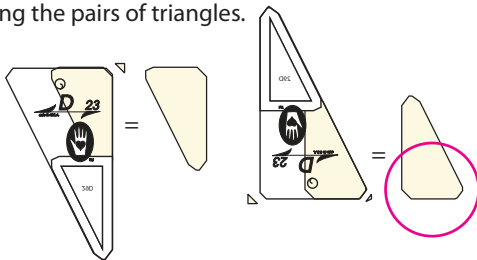

Our engineered corners for Spike also require a strip ⅛" wider than you'd expect. The paper 29B template is only being used to establish a straight baseline. Align D-22 at the top of the strip

and cut the triangle. (See page 2.) Don't worry—the pieces will fit together. To cut the next triangle, rotate the template and align the same way.

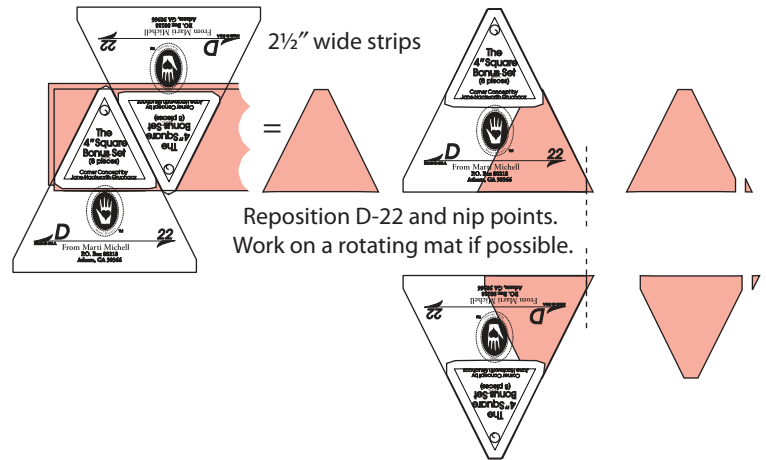

Making the Block

Join pieces into nine 2½" square (B-12) sub-units as shown in book.

- Add D-29 corners to opposite sides of D-28 center square to make the center Square Within a Square unit. Press toward the square. Then add remaining corners and press toward triangles. Make 1.

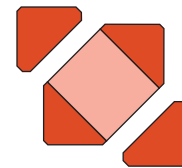

- Make the Peaky and Spike Units. Join small right triangle to center triangle. Press toward small triangle. Repeat on second side. Make 4.

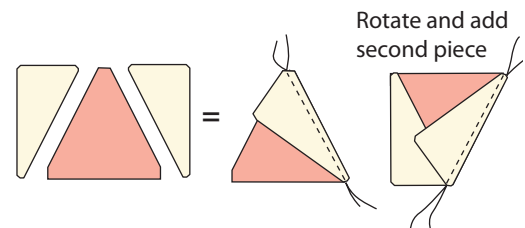

- Join B-13 triangles to make 4 half-square triangle units.
- Arrange and join into 3 rows. This is a block that does not have perfect pressing options. Press toward corners and center or press seams open. Join rows to complete the block.

From MARTI MICHELL corners are designed to align perfectly for sewing:

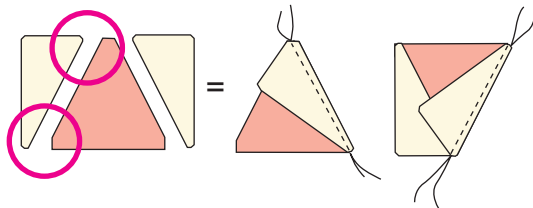

The top of the paper pattern will be approximately $\frac{1}{16}$ " below the edge of the $2\frac{5}{8}$ " wide strip.

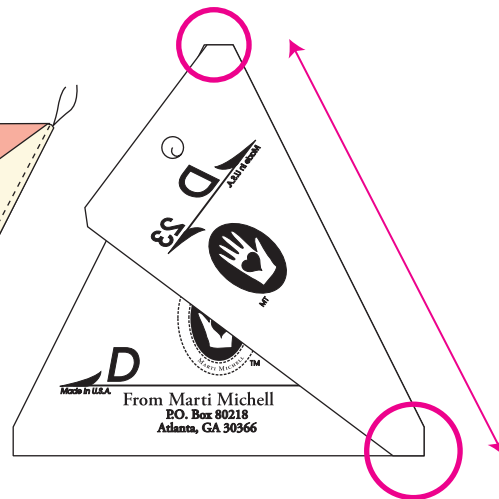

So template 23 is longer than template 22 and thus requires a wider strip than #22.

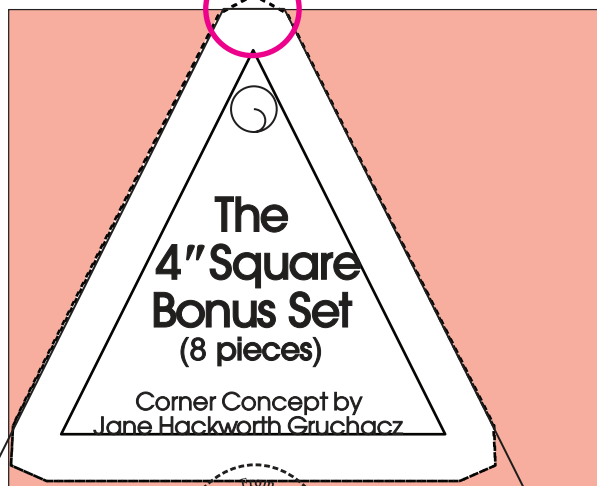
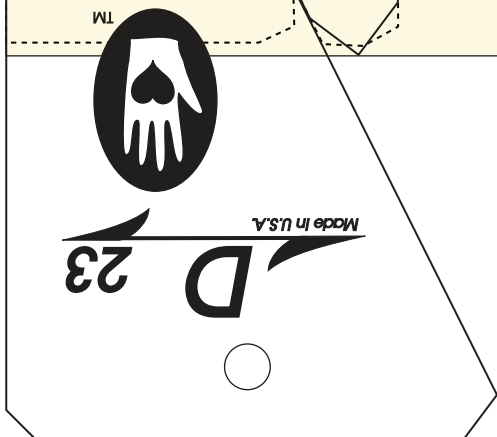
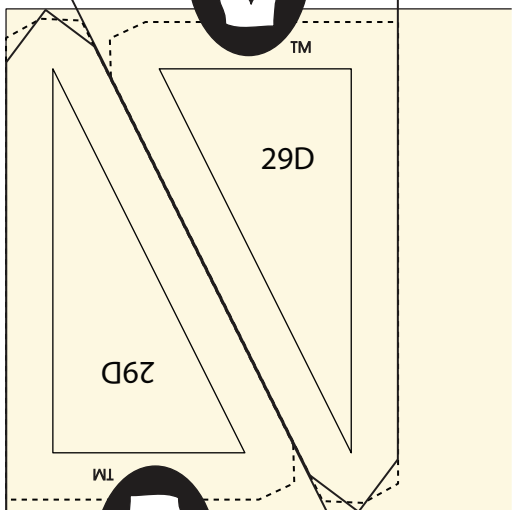
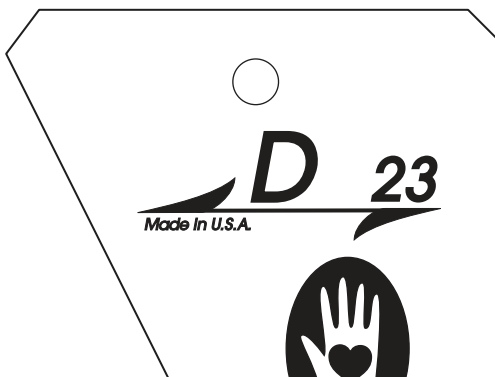
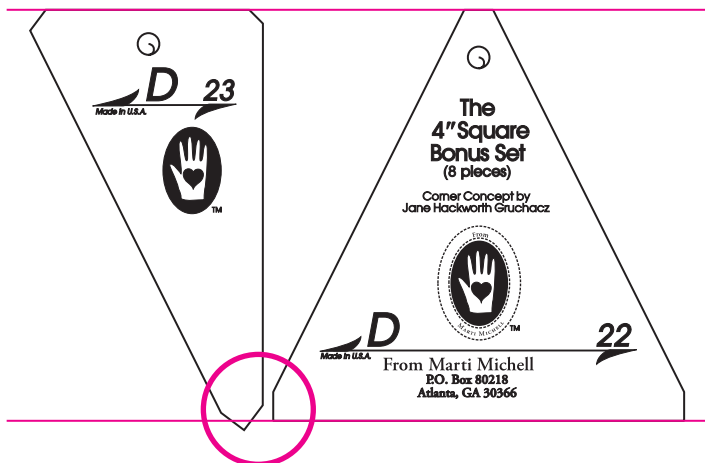

$2\frac{1}{2}$ " strip width is correct.

Align FMM D-22 at the top of the strip. This will leave a little extra fabric below the paper template, and that is correct. Do not trim the bottom of the fabric triangle. The paper template is being used only to indicate a straight line for alignment.

