

OVICX

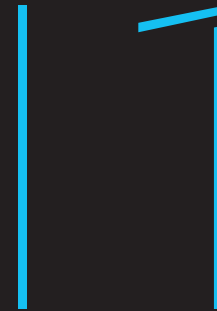

Treadmill instruction manual





CONTENTS

1.Product Brief Introduction	01
2.Safety Instruction	02
3.Parameter and Component	04
4.Installation Instruction	05
5.Button Instruction	07
5.1 Function Introduction	08
5.2 Error Code Display	09
6.Exercise Suggestion and Guideline	11
7.Maintenance Guidance and Instruction	13

About After-sales Service

We would love to hear from you, if you have any questions, do not hesitate to contact us

Email: support@qiaosports.com

1. Product Brief Introduction

Product Name: Treadmill

Product Model: OVICX-I1

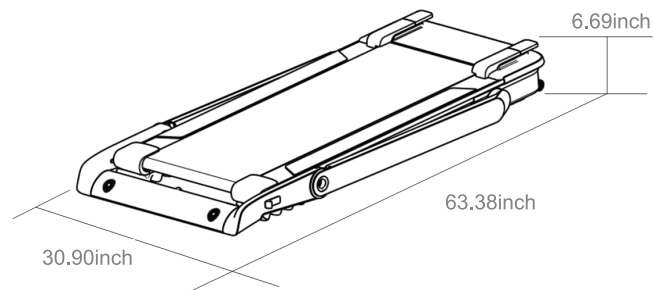
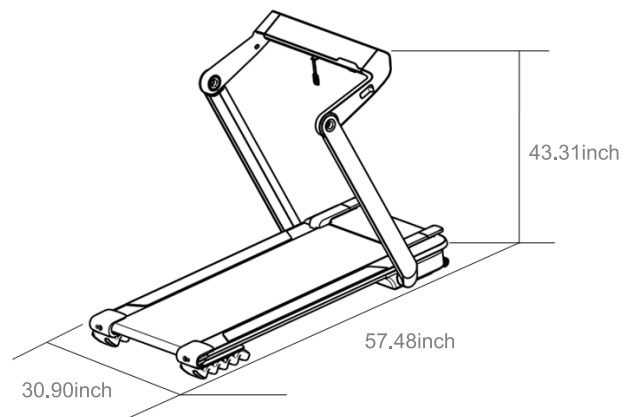

Thank you for choosing our product.

The correct use of treadmill is the guarantee for your safety and convenience.

Please read the following contents carefully before you use the treadmill.

1. Please make sure you have installed the treadmill correctly before powering it on. For an easy plugging in, be careful not to cover the socket on the wall when placing your treadmill please.
2. Please plug power cord into the socket connected to ground for safety. The plug of the treadmill is special, if the power cord got damaged, please keep it away from our distributor or contact us directly.
3. The treadmill is the indoor equipment, please do not use it outdoor. The place where to place the treadmill should be clean and flat. Please keep it away from moisture. Please do not put the treadmill on anything such as thick blanket which may influence the air circulation under the treadmill or influence balance of the user. The treadmill is special equipment, so please do not to change it for any other usages.
4. Do not wear too large or too loose clothes when doing exercise, in order to prevent accidents from your clothes hung to any parts of the treadmill. We recommend you wear sneakers and gym shoes with rubber bottom.
5. Please do not take off protection cover casually. If you do need to open it for maintenance, please plug off the power cord first.
6. If it is the first time for you to use the treadmill, please do remember to grab the handrails till you feel comfortable.
7. If the treadmill accelerates suddenly or increases its speed automatically caused by the problem of electronic meter system, please pull out the safety key to stop the equipment instantly.
8. Please plug off and lay power cord away when not using the treadmill.
9. To avoid any risk, you should not allow children close to the treadmill when it is on.
10. There should be adult accompanying when children use the treadmill.
11. Before exercise, please warm up for 3-5 minutes, such as exercising joint and jogging.
12. Turn on power on the bottom to start the treadmill. Press "on/off" button, and digital display shows "Start" and then the treadmill begins to work. The system shall choose speed "0.6mph" automatically, and the beginner could take this speed to warm up.
13. Grab the front ends of the handrails by two hands, step onto the treadmill and increase the speed to 0.9 to 1.2mph slowly. Keep your body straight, relax as much as possible, and walk with the running belt. After the beginner could take this speed to warm up.
14. After getting familiar with the treadmill functions, you can preset the exercise time and adjust it according to your own physique.
15. On the digital display, you can clearly see the speed, time and distance of your exercise. Also, it can show the calorie you consumed and your heart rate on the digital display. During running, your heart beat rate could be measured by grabbing the chips on the two handrails.

16. **Warning!** Equipped with a 2.29ft red magnetic safety thread (the red one, combined with safety lock together). If you find the treadmills abnormal or feel risk, please pull out this magnetic safety thread to stop the treadmill instantly in order to avoid accident occurrence.

17. While exercising, please clip the safety lock (red) thread on suitable position of your clothes, in order to pull it out to stop the treadmill immediately and ensure safety when accident occurs. When you do not use the treadmill, please well keep safety lock to avoid and third party to use it uncontrolled.

18. When finishing your exercise, please plug off and put away power cord well.

19. **Warning!** Touching any parts in motion is forbidden.

20. Heart rate sensor is not medical equipment. A lot of causes may lead to inaccurate test results, so the test results are only for reference.

21. **Warning!** If you feel any potential danger during the exercise, you should utilize the two side handrails to jump to ground or jump to two side foot boards urgently.

22. **Warning!** 78.74*39.37 inch safety spare area behind the treadmill is required, so that you can have enough space to jump off the working treadmill when any danger occurs.

23. During exercise, 78.74 (Length)*39.37 (Width)*88.58 (Height) inch free space is required for safe operation.

24. **Warning!** The treadmill is indoor equipment. Please do not use it outdoor. Exercising on the treadmill is aerobic exercise to strengthen the functions of your heart and lung. Muscle exercise is auxiliary.

25. **Warning!** Any adjustment devices that may interfere with the user's motion should not deviate from the design

Hints:

1. Beginners shall get familiar with the function buttons on the panel before using the treadmill.
2. In case of falling down, please stand on the EVA anti-skid plates on both sides first when starting the treadmill instead of standing on the running belt directly.
3. Before running, please put on your sportswear instead of jeans or leather shoes.
4. Please do not play with other people while using the treadmill. It is strictly forbidden to jump off the treadmill during the running process.

3.Product Technology Parameter and Component List

Technology Parameter

Product Model	OVICX-I1
Unfolded Size	57.48*30.90*43.31 inch
Speed	7.5mph
Rated Voltage	110V~
Rated Frequency	50/60Hz
Rated Power	1.25HP
Efficient Running Area	18.11*47.24 inch
Display	LED
Gross Weight	130.07lbs
Net Weight	112.44lbs
Dimensions	67.71*34.84*8.46 inch
Category and Level	HB
App Connectivity	✆
Safety Protection	1. Safety switch on the meter 2. Overcurrent fuse on the treadmill's internal control panel

Product executive standard:

- 1.GB17498.1-2008 general safety requirement and test method.
- 2.GB17498.6-2008 additional special safety requirement and test method of the treadmill.

We reserve the rights to improve or change the pictures and technology parameters of this product without prior notice. Please understand.

Component List

No.	Name	Qty	Remarks
1	Entire machine (base, main frame and electric meter)	1pc	
2	Spare parts box	1box	Hexagon wrench 1pc Lubricating silicone oil 1 bottle
3	Instruction manual, Warranty Card, Certificate After-sales service brief hints	1pc of each	

4.Installation Instruction

Simple installation in 4 steps

1. Open the package, take out the treadmill, spare parts box, power cord, instruction manual from the box

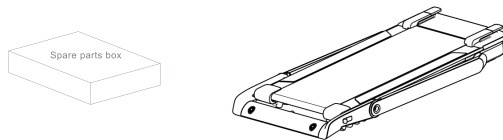

2.Treadmill unfolding

- 2.1 Unfold the handrails, shake them back and forth after unfolding. It indicates that the handrails are locked in place if the handrails are unmovable when shaking

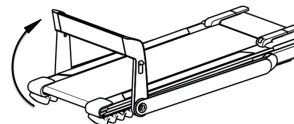

- 2.2 Unfold and shake the uprights. It indicates that the uprights are locked in place if uprights are unmovable when pressing hardly.

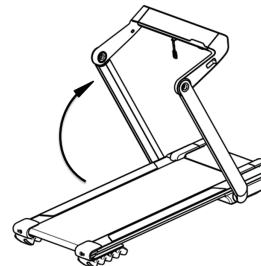

3.Treadmill Folding

- 3.1 Uprights unlocking. Step on the foot pedal on the bottom left, and then lay flat the uprights.

Note: If the foot pedal is stuck, please shake the uprights back and forth and try to unlock again. This phenomenon is a normal phenomenon caused by the principle of the locking mechanism, not a machine breakdown.

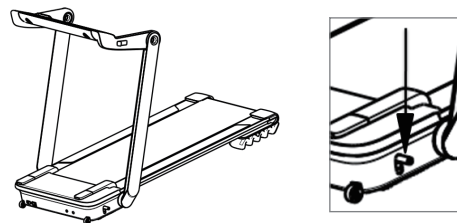

4. Installation Instruction

3.2 Pull up the support frame, hold tightly the two places shown in the picture, pull it as the picture shows.

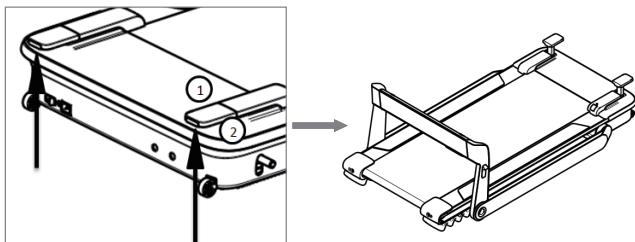

3.3 If fold uprightly is needed, hold the cross tube as shown in picture 1 with both hands and lift the treadmill up.

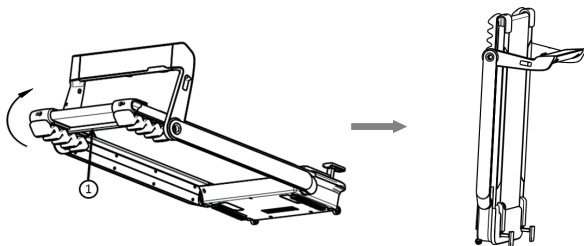

3.4 Unfold the handrails, pull forward as shown in the picture to unlock and straighten the armrests.

Note:

- 1) You need to push the unlock button on both sides at the same time.
- 2) The unlocking process should be applied slowly to prevent the treadmill from falling backwards.
- 3) The upright treadmill should be placed against the wall, away from the active area for children under 5 years of age.

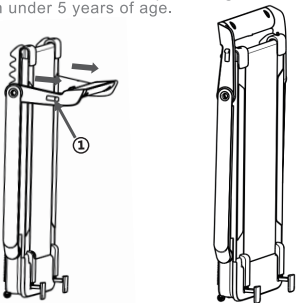

4. Check that the above installation is secure before starting the treadmill.

5. Button Instruction

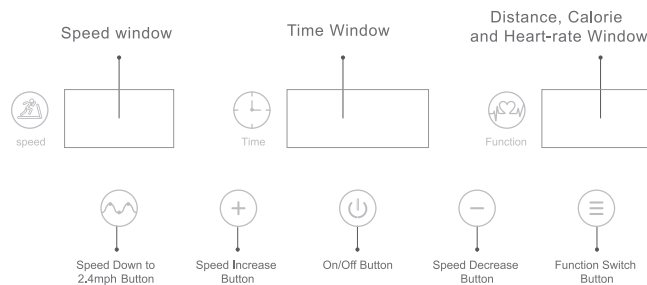

(1). Operation Window Display

1. Speed Window

It shows the current speed of running belt,
Unit: mph ; Accuracy: 0.1mph

2. Distance, Calorie and Heart-rate Window

2.1 When distance indicator light is on, it displays the total Distance from the start of the workout.

Unit: mile ; Accuracy: 0.01mile

2.2 When Calorie indicator light is on, it displays your total calorie

Expenditure from the start of the workout.

Unit: kcal; Accuracy: 0.01kcal

2.3 It shows your heart-rate once it gets the data of your hand pulse.

Unit: bpm, Accuracy: 1bpm

3. Time Window

3.1 It displays the running time. (Range:0-99:59)

3.2 It displays the error code when failure occurs

4. Indicator Light

4.1 Calorie Indicator Light: When the window displays calorie date, the calorie indicator light will be on.



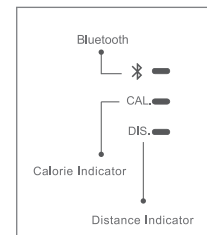

4.2 Distance Indicator Light: When the window displays distance data, the distance indicator light will be on

5. When the red safety key is released, regardless of the speed of the treadmill, the motor will stop running in the shortest time and the time window on the electronic meter will display ER1.



5.1 Button Instruction

(2). Button and function:

- 1  On/off: Press the button to start the treadmill
- 2  Switch button: Press this button to switch distance, calorie data in the display window.
- 3  Plus: Adjust the speed. Each press of the button, speed increases by 0.1
- 4  Minus: Adjust the speed. Each press of the button, speed decreases by 0.1
- 5  Speed down: Press this button when feeling tired, then the treadmill will switch into the walking state 2.4mph. And press this button again after a break, the running speed will automatically go back to the previous speed.

(3) USB charging function:

The device can be charged via the USB cable.

5.2 Error code display

A: Error information of control device and troubleshooting methods

Information Code	Possible reasons	Troubleshooting Guideline
ER 1	Safety key disconnected	1.1 Check whether the safety key is connected to the designated position. 1.2 Check whether the safety key is loosen or dropped 1.3 Check or replace the safety key
ER 2	Speed sensor failure	2.1 Check or replace the speed sensor.
ER 3 ER 4 ER 5	Problem on the controller	3.1 Check or replace the controller.
ER 6	Over current protection	4.1 Check if overloaded 4.2 Check if the mechanical running parts are jammed 4.3 Check if there is a lack of lubricant oil. When lack of lubricant oil, the friction between plate and belt would increase 4.4 Check if the running plate is badly worn 4.5 Check if the running belt is badly worn 4.6 Check if the motor is severely short-circuited 4.7 Check or replace the controller 4.8 Check or replace the motor
ER 7	Problem on the motor or Motor disconnected	5.1 Check if the motor cable is loose or dropped. 5.2 Check or replace the motor. 5.3 Check or replace the controller
ER 9	Overload protection	6.1 Check if overloaded 6.2 Check if the mechanical running parts are jammed 6.3 Check if there is a lack of lubricant oil. When lack of lubricant oil, the friction between plate and belt would increase 6.4 Check if the running plate is badly worn

Information Code	Possible reasons	Troubleshooting Guideline
ER 10	Overvoltage protection	7.1 Please check if the voltage on the power supply line is in the normal range. DC 110V~ 7.2 Check or replace the controller 7.3 Check or replace the motor
ER 11	Over current	8.1 Check or replace the motor
ER 12	electric motor short circuit	9.1 Check whether there is any foreign bodies at the output end of the controller causing short circuit 9.2 Check or replace the controller

Remark 3:

When it is detected that no one runs on the treadmill for more than 5 seconds, the data of time, distance and calorie on the display window would not increase while the treadmill will continue to run at the current speed.

If it is your first time to use electronic running machine, you need to read the below content:

Preparation

Before exercise, it is better to know your own health status in order to make an exercise plan based on it. It is recommended to consult a doctor or a professional to get multiplier effects.

Before first use of the running machine, please stand by it and learn how to control it, for example: start, stop, adjust speed and etc. After getting familiar with it, you can start to use the running machine. Stand on the plastic anti-slip plates on the two sides of the track and seize the handrails by two hands. Then, turn on the running machine and adjust the speed around 0.99-1.99mph (low speed). Keep your body straight and your eyes look forward. Step on the running belt carefully and relax yourself until you can gradually follow the speed. When you are comfortable, you may slowly increase the speed to 1.86-3.1mph. Keep this speed for about 10 minutes, and then slow down it until it stops. For your first time, please do not run at high speed to prevent from falling down.

Exercise

Walk about 0.62mile at a fixed pace and record the time it spent. It may take 15-25 minutes. When the speed is at 2.98mph, it shall take you about 20 minutes for a distance of 0.62mile. After you can easily do it for a few times, you can gradually increase the speed. Keep it for 30 minutes, and you can get a good exercise. Before you start to walk, please be patient and be aware that this exercise is good for your health during the whole life time. It is not a magic to change something overnight.

The Frequency of Exercise

Your target is to exercise 3-5 times every week, and each time exercise for 15-60 minutes. It is better to make an exercise schedule based on your body status, rather than do it according to your own preferences. You can control the intensity by adjusting the speed and exercise time.

Exercise Time

Shortcut: 15-20 minutes exercise is a good way to save time. Warm up for 5 minutes at 2.49-2.98mph, and then increase speed by 0.19mph increment per minute until you feel at a suitable speed, and keep running for about 45 minutes. You will fully enjoy this exercise.

The above content is for reference only. Please consult professionals for more details.

Wearing

The only thing you need is just a pair of good shoes, and we recommend you to wear running shoes or gym shoes during exercise. Meanwhile, please be careful that there is nothing stuck on the shoes in order to avoid from anything dropping into running machine and then damaging the running plate and belt. Clothes should be comfortable and suitable for sports, and we recommend you to wear the breathable sportswear made from cotton.

No matter how fast you walk, it is better to do stretch exercises first. Warm muscle is easier to stretch, so please spend 5-10 minute to warm up first. Then stop and use the below methods to do stretch exercises. Stretch for 5 times and at least 10 seconds for each leg in warm-up, and do it again after exercise.

1. Stretch down

Keep your knees slightly curved, and slowly bend your body forward. Relax your back and shoulder and touch your toes with your hands (see figure 1). Keep this for 10-15 seconds, and then relax. Repeat it for 3 times.

2. Foot tendon stretch

Sit on a clean cushion, stretch one leg out and adduct another leg to cling the inner side of the leg stretched-out, and then touch the toes by hand (see figure 2). Keep this gesture for 10-15 seconds and then relax. Repeat three times for each leg.

3. Foot and heel tendon stretch

Stand with your hands on the wall and separate your two legs forward and back. Lean toward the wall, and keep the back leg straight and put its heel to floor (see figure 3). Keep this gesture for 10-15 seconds and then relax. Repeat 3 times for each leg.

4. Quadriceps stretch

Hold wall or table by your left hand for balancing, extend your right hand backward to grasp your right ankle, slowly pull the heel toward your butt until you feel tightness of the front muscle on your thigh (see figure 4). Keep this gesture for 10-15 seconds and then relax. Repeat 3 times for each leg.

5. Sartorius muscle (inner muscle of thigh) stretch

Sit down with two soles facing each other and two knees outwards. Grasp the two feet and pull them towards your groin. Keep this gesture for 10-15 seconds, and then relax. Repeat 3 times.

Exercise safety measures

Please consult a professional before exercise. He can give you some suggestions about exercise frequency, intensity and duration according to your age and physical condition. During exercise, if you feel chest choking or chest pain, irregular heartbeat, breath difficulty, dizziness or any other discomfort, please stop immediately. And consult professionals before you resume the exercise.

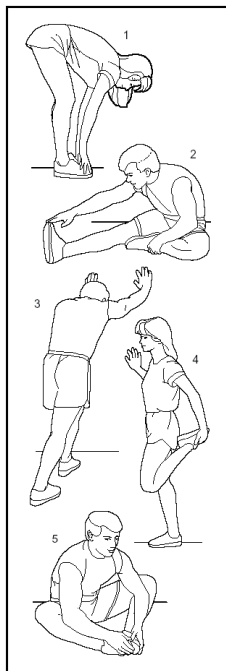

1. Maintenance guideline

WARNING: Be sure that the electric running machine is not plugged in before you clean or maintain the product.

Cleaning: A comprehensive cleaning shall significantly extend the product life.

Remove dust regularly to keep parts clean. It is necessary to clean the exposed parts on two sides out of the belt, and this shall decrease dust accumulation under the belt. Be sure your sports shoes are clean before exercise and this could avoid lint from dropping into the running machine and then damaging the running plate and belt. Scrub the belt surface by a wet cloth with soap, and be careful not to spill water on the electrical components or under the belt.

The running machine has been pre-coated with silicone oil between the running plate and belt. It is necessary to lubricate it by silicone oil regularly, because the friction between the running belt and plate has big impact on product life and performance. We recommend you to take regular inspection on the running plate. If the running plate is damaged, please contact our customer service center.

We recommend the user to inject the silicone oil between running belt and plate according to the following timetable:

Low frequency users (use time: less than 3 hours per week): inject silicone oil once every 6 months

Middle frequency users (use time: 3-5 hours per week): inject silicone oil once every 3 months

High frequency users (use time: more than 5 hours per week): inject silicone oil once every 1.5 months

We recommend you to buy silicone oil from your local distributor or contact us directly.

2. Maintenance instruction

In order to maintain your running machine better to extend product life, it is recommended to turn off the running machine after using it for 2 hours, and have a 10 min break before continue.

If the running belt is too loose, it could be slippery when you exercise; if too tight, it may decrease the motor performance and increase the abrasion of drum and running belt. You can check whether the running belt is fitting or not by raising the two sides of running belt horizontally by hands. The suitable distance between raised running belt and plate is 1.97-2.95 inch.

2.1 Running plate lubrication

We mentioned above that it is necessary to inject silicone oil on running plate at the right time. But please do not use excessive silicone oil as the lubricants are not the more the better. Remember: proper lubrication is an important factor in extending the product life of a running machine.

The method to check whether it is necessary to inject silicone oil
Raise the running belt and stretch your hand as far as possible to touch the central part of the back side of the running belt. If your hands can grab a little silicone oil (feel slightly moist), that means you do not need to inject silicone oil. If the running plate is dry and no silicone oil adhered to your hand, then you need to inject silicone oil.

The procedure to inject silicone oil on the running plate:

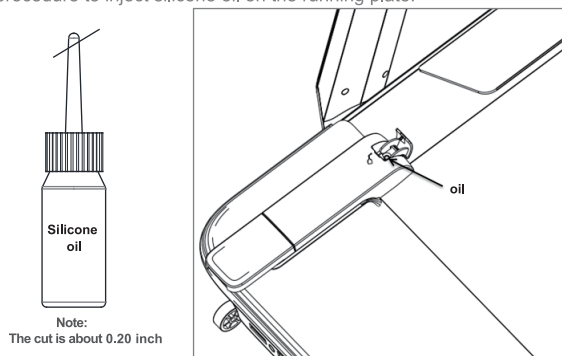

a) As shown in the picture, cut the oil bottle mouth, twist off the long mouth cover, tear the inner sealing paper, and then tighten the long mouth cover. In order to make a good connection with the oil hole, do not cut too long when cutting the mouth, about 0.20 inch or less, as long as the oil can flow out.

b) Turn on the treadmill and run it at the lowest speed (0.6mph), then lubricate the running belt as shown in the picture

c) **Align the oil bottle with the oil filler**, squeeze the oil bottle slowly to let the oil flow into the running belt through the oil pipe, and run the treadmill at a speed of 0.6mph to evenly apply the silicone oil, and lightly tap on the belt in the middle. In a few minutes, the silicone oil can be completely absorbed by the running belt.

2.2 Tautness adjustment of the running belt.

The running belt has been adjusted to a suitable tautness twice after the installation and before delivery. However, after use for a period of time, the running belt could be somehow loose. For example: the user may feel standstill or slippery during his running. When this phenomenon occurs, please adjust the tautness of the running belt by rotating the both left and right adjusting bolts clockwise with a half circle as a unit. (to tighten the running belt, please operate in an anticlockwise direction). If the running belt is too loose, the user will feel slippery when running; while it is also not good if the running belt is too tight, because it shall increase the motor load and damage the motor, running belt, the roller and etc.

2.3 Running belt centering

1. Place the running machine on even ground.
2. Start the running machine and set the speed at about 2.1mph.
3. If the running belt is tilted to the left side, rotate the adjustment bolt on the left side by 1/2 circle in the clockwise direction, and then rotate the adjustment bolt on the right side by 1/2 circle in an anticlockwise direction.
4. If the running belt is tilted to the right side, rotate the adjustment bolt on the right side by 1/2 circle in the clockwise direction, and then rotate the adjustment bolt on the left side by 1/2 circle in an anticlockwise direction.

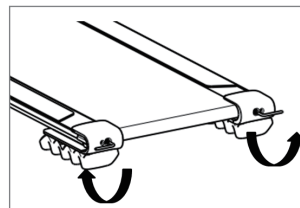

If the running belt is tilted to the left side, rotate the adjusting bolt on the left side clockwise or rotate the adjusting bolt on the right side counterclockwise

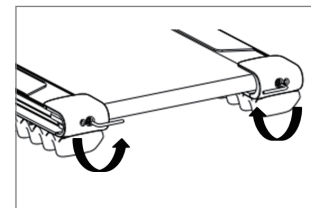

If the running belt is tilted to the right side, rotate the adjusting bolt on the right side clockwise or rotate the adjusting bolt on the left side counterclockwise

2.3 Running belt centering

1. Place the running machine on even ground.
2. Start the running machine and set the speed at about 2.1mph.
3. If the running belt is tilted to the left side, rotate the adjustment bolt on the left side by 1/2 circle in the clockwise direction, and then rotate the adjustment bolt on the right side by 1/2 circle in an anticlockwise direction.
4. If the running belt is tilted to the right side, rotate the adjustment bolt on the right side by 1/2 circle in the clockwise direction, and then rotate the adjustment bolt on the left side by 1/2 circle in an anticlockwise direction.

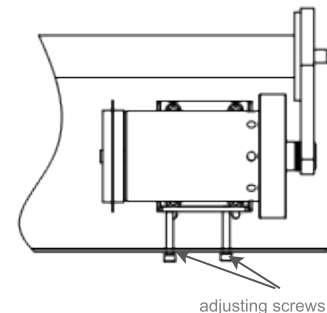

adjusting screws