

Pendant lamp / small

white Art. No. duc s p w

gray Art. No. duc s p g

Material - marble breakstone, Swarovski crystals

Light-bulb - 1 x max 30W E14

Voltage - 220-240 V - 50/60 Hz

Weight - ~ 2 kg

Suspension - steel

Ceiling cap - painted steel

Electrical cable - black textile lined

Environment - indoor



Packaging - 35 x 23 x 14 cm / weight - 3 kg

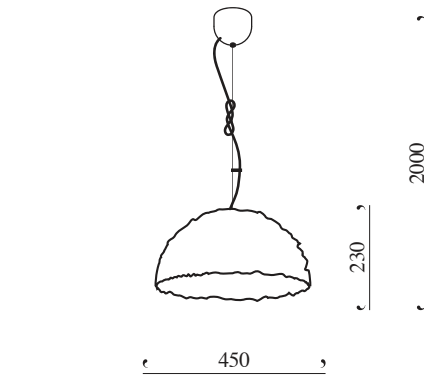

Pendant lamp / medium

white Art. No. duc m p w

gray Art. No. duc m p g

Material - marble breakstone, Swarovski crystals

Light-bulb - 1 x max 150W E27

Voltage - 220-240 V - 50/60 Hz

Weight - ~10 kg

Suspension - steel

Ceiling cap - painted steel

Electrical cable - black textile lined

Environment - indoor



Packaging - 53 x 53 x 33 cm / weight - 17 kg (wooden box)

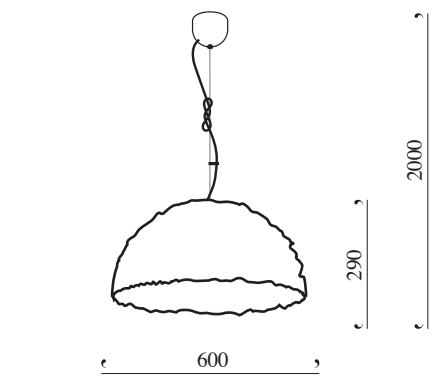

Pendant lamp / large

white Art. No. duc l p w

gray Art. No. duc l p g

Material - marble breakstone, Swarovski crystals

Light-bulb - 1 x max 150W E27

Voltage - 220-240 V - 50/60 Hz

Weight - ~21 kg

Suspension - steel

Ceiling cap - painted steel

Electrical cable - black textile lined

Environment - indoor



Packaging - 64 x 64 x 39 cm / weight - 24 kg (wooden box)

The Duchess undoubtedly possesses her own discrete charm. Her belonging to the highest circles is confirmed by her refined decoration, which is entirely handmade from Swarovski crystal.

The Duchess is characterized by an eternally classical semi-spherical form. However, the material from which it is formed is surprising - various manifestations of stone. In this lamp, the rougher face of stone - marble chips meets the elegant refinement of Swarovski crystal.

Both materials on the lamp's outer shell are masterfully combined, creating a unique texture. No two Duchess on earth are the same. Enjoy the Duchess' constantly changing and elusive shine!