



# DB001 Off Road Dirt Bike User Manual



Digital User Manual

[www.frptoys.com](http://www.frptoys.com)  
[csr@frptoys.com](mailto:csr@frptoys.com)  
833-970-3777 (Toll Free)  
M-F 8am-5pm PST

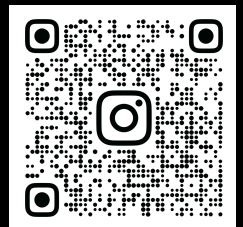



## CAUTION SAFE FOR USE

△ This mark notices a very important item for safety. Be sure to observe the notice.

1. Engine oil: Gasoline (1:50) is mixed in the oil tank. More than 92 gasoline or gasoline with 10% ethanol are applicable on this vehicle. For engine oil please use 2-stroke oil (JASO FC). When you supply engine oil and gasoline to vehicles, please turn off the engine to avoid fire or explosion danger.
2. Do not use 4-cycle engine oil. (Otherwise, it causes the plug to be degraded, the piston ring to seize or the muffler to be clogged.)



Failure to follow these  
**INSTRUCTIONS WILL VOID YOUR WARRANTY!**

This **PRODUCT IS NOT INTENDED FOR EXTREME** Use!

Please take care of your motorcycle.

**DO NOT JUMP or ABUSE THIS PRODUCT!**

**DO NOT RIDE IN WET/ICY CONDITIONS!**

Failure to follow these instructions properly or abusing your motorcycle will **VOID YOUR WARRANTY!**



## CAUTION PROHIBITED ITEMS

△ Do not allow anyone who does not understand this instruction manual to operate the bike.

△ Racing should use a mixture of unleaded gasoline and two-cycle engine oil. The volume ratio is 50:1. Do not use any degraded fuel (which smells sour) or fuel of the wrong mixture ratio. It will cause a poor start, insufficient output, or damage to the engine.

△ Do not use 4-cycle engine oil. (Otherwise, it causes the plug to be degraded, the piston ring to seize or the muffler to be clogged).

△ Do not run the engine in a room or poorly ventilated area. (The exhaust gas includes odorless but hazardous carbon monoxide.)

△ Do not put your hand or foot near any moving or rotating part of the engine.

△ Do not store, spill, or use any gasoline near a fire, stove, oven, boiler, or other instruments that use a pilot light or spark. (Otherwise, it may cause an explosion.)

△ Smoking is strictly prohibited while refilling the fuel.

△ While the engine is running or while it remains hot soon after stopping, do not remove the lid of the fuel tank or refill the fuel. (Before or refilling the fuel, stop the engine and cool it down for 2 minutes or more.)

△ If any gasoline split or smelled or any danger of explosion is felt, do not run the engine.

△ Do not stop the engine while the choke lever is in the closed position.

△ Do not aimlessly adjust the revolution speed setting of the engine.

△ Do not check any spark while keeping the spark plug removed.

△ Do not run the engine with the muffler or air cleaner cover removed.

△ Do not touch any hot, muffler or engine part (Otherwise, it may cause a burn).

△ When the engine runs, do not touch any spark plug cap or high-tension cord. (Otherwise, it may cause an electric shock and harm your body).

△ Do not run any engine as a single unit (Be sure to run with the racing).

**△ ALWAYS WEAR HELMET&SAFETY GEAR.**

**△ ALWAYS CHECK THE BRAKE INSTRUMENTS BEFORE RIDING.**

**△ DO NOT RIDE IN RAINING, SNOWING DAY, SLIPPERY SURFACE, OR UNSTABLE DUE GRAVEL, SAND, etc.**

**△ PREGNANT PERSONS SHOULD NOT USE THIS PRODUCT.**

**△ NEVER USE ALCOHOL OR DRUGS BEFORE OR WHILE OPERATING.**

**△ DO NOT STOP THE SCOOTER SUDDENLY** (Run slowly for 3-5 minutes after start-up or before stopping).

This bike is not intended for operation on pedestrians, streets, highways, and freeways.

Please check with your local Department of Motor Vehicles for regulations in your country.

# **IMPORTANT**



Please read before using this product.  
**READ THIS FIRST!**

## **WARNING**

This product does not conform to Federal Motor Vehicle Standards and is not intended for operation on public streets, roads, or highways. Serious injury can result from the unsafe operations of this product.

Operators can minimize these risks by using certain safety equipment such as safety helmets, goggles, gloves, elbow and kneepads, and appropriate footwear.

**DO NOT** operate this product in traffic, on wet, frozen, oily, or unpaved surfaces, or under the influence of drugs and/or alcohol. Avoid uneven surfaces, potholes, surface cracks, and obstacles.

**DO NOT** use a water hose to clean this product. See Product Handbook for more information.

This product is recommended for riders **13 YEARS OF AGE and older**.

## **SAFETY**

Persons without excellent vision, balance, coordination, reflexes, muscle and bone strength, and good decision-making capabilities should not use this product.

Minors without adult supervision should not use this product.

Persons unwilling or unable to take responsibility for their own actions should not use this product.

The user of this product assumes **ALL** risks associated with its use. To minimize these **RISKS**, the user must wear appropriate safety gear such as a helmet, goggles, gloves, elbow and kneepads, and appropriate footwear.

**Never** start the engine inside a closed room or building.

Breathing exhaust fumes can be fatal.



# QUICK REFERENCE SAFETY GUIDE

## Fuel Safety

Mix and pour fuel outdoors away from sparks or flames.

Only use a container approved for fuel.

Do not smoke or allow smoking near the motorcycle while working on the engine, or while the engine is running.

Wipe up and clean all fuel spills before starting the engine.

Move at least 10 feet away from where you fueled before starting the engine.

Stop the engine before removing the fuel cap.

It is recommended that you empty the fuel tank prior to shipping or storage to prevent fuel leaks.

Do not store your motorcycle near open flames, furnaces, electric motors, or switches.

## Maintenance

Maintain your motorcycle as recommended in this Product Handbook.

Disconnect the spark plug cap before performing any engine maintenance, except for carburetor adjustments.

Keep others away while making carburetor adjustments.

Use only quality replacement parts as recommended by the manufacturer.

## Transportation and Storage

Carry your motorcycle by the handlebar tube with the engine off and the muffler away from your body.

Allow the engine to cool, empty the fuel tank, and fold the motorcycle before carrying or storage.

It is recommended that you empty the fuel tank prior to shipping or storage to prevent fuel leaks.

Clean the motorcycle carefully and store it in a cool, dry place.

## Product Safety

Keep hands and feet away from moving parts.

Inspect the entire product prior to each use. Replace damaged parts.

Check for fuel leaks and make sure all fasteners are in place and securely fastened.

Replace all parts that are cracked, chipped, or damaged before use.

Use only parts and accessories that are recommended by the manufacturer.

If a situation arises that is not covered in the manual, proceed with caution and use good judgment.

Contact your dealer if you need further assistance.

# TABLE OF CONTENTS

<b>1 VEHICLE INTRODUCTION</b>	1
1.1 Technical Specification	1
1.2 Mini Parts Description	2
<b>2 BEFORE STARTING</b>	3
<b>3 FAST INSTALLATION</b>	4
3.1 Install Front Wheel	4
3.2 Install Handlebar	5
3.3 Install Rear Suspension	5
3.4 Install Number Plate	6
3.5 Install Front Fender	6
<b>4 PREPARING FOR USE</b>	7
4.1 Before Start-up	7
4.2 Before Riding	8
4.3 Starting the Dirt Bike	9
<b>5 OPERATION</b>	10
5.1 Operation and Running	10
5.2 Operating Procedures	10
<b>6 CONTROLS</b>	11
6.1 Braking	11
6.2 Braking System	11
6.3 Stopping	11
<b>7 ADJUSTMENT</b>	12
7.1 Carburetor Adjustment	12
7.2 Brake Adjustment	12
7.3 Chain Adjustment	13
<b>8 MAINTENANCE AND STORAGE</b>	14
8.1 Maintenance Schedule	14
8.2 Storage	14
<b>9 TROUBLE SHOOTING</b>	15



# VEHICLE INTRODUCTION

## 1.1 Technical Specification

**Engine type:** 49.4cc 2-stroke/EPA Approved

**Fuel:** Unleaded petrol & 2-cycle engine oil mixing

**Oil Mixing Ratio:** 50:1

**Start Mode:** Hand Pull Start

**Brake:** Rear disc brake

**Tire:** 12 1/2\*10, off-road tire

**Max Load:** 127.9 lbs(58kgs)

**Net Weight:** 48.5 lbs(22kgs)

**Fuel Capacity:** 0.26gal(1L)

**Driving Method:** T8F Chain

**Packing:** Carton

**Steering Bar Angle:** 45 °

**LxWxH:** 43"x26"x28"



# VEHICLE INTRODUCTION

## 1.1 Mini Parts Description





# BEFORE STARTING

Please unpack the contents of the box. Remove the foam separators that are intended to safeguard the components during transportation. Thoroughly examine the contents of the box for any signs of paint scratches, dents, or cables that may have been bent during shipping.

It is important to note that since the Dirt Bike is 95 percent assembled and carefully packaged at the factory, minor blemishes or dents on the box should not pose any concerns.

**Before getting started, it is crucial to ensure that the package encompasses all the necessary components.**



**Prior to performing any maintenance procedures, it is imperative to ensure that the kill switch is in the "OFF" position.**

Estimated installation time: 30 minutes for an adult.

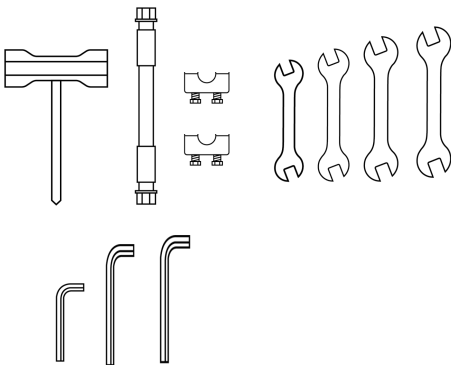

From left to right, they are:

- Spark Plug Socket
- Front wheel bearings
- Handlebar Presses
- 8-10mm Wrench
- 12-14mm Wrench
- 13-15mm Wrench
- 14-17mm Wrench
- 4mm Allen Wrench
- 5mm Allen Wrench
- 6mm Allen Wrench

# FAST INSTALLATION

## 3.1 Install Front Wheel

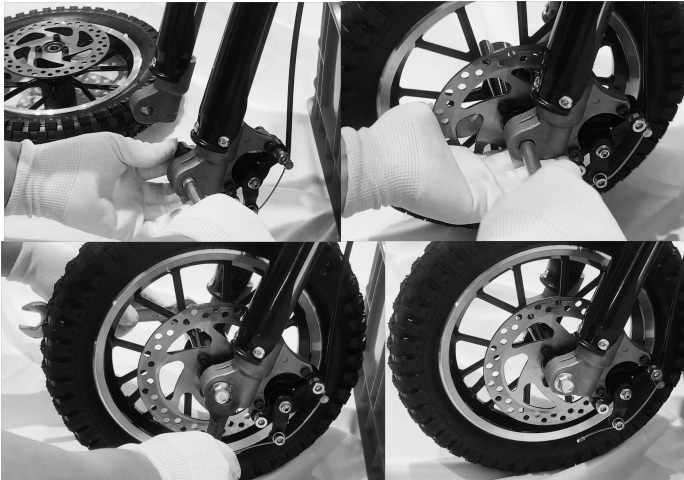

1. Place the vehicle in an upright position with the front fork approximately 20cm off the ground.
2. Locate the components as shown in the diagram.
3. Thread the axle through the left side of the frame and insert it into the spacer sleeve.
4. Align the side of the wheel with the brake rotor facing the spacer sleeve, then place the front wheel into the front fork.
5. Thread the axle through the front wheel and insert it into the spacer sleeve. Tighten the nut using the wrench.
6. Verify that the front wheel is installed properly, rotates freely, and exhibits no signs of looseness or instability.

# FAST INSTALLATION

## 3.2 Install Handlebar



1. Loosen the screws on the handlebar presses, then insert the entire handlebar press into the screw holes above the front fork.
2. Secure the handlebar press in place using a nut.
3. Tighten the handlebar presses using the wrenches.
4. Adjust the handlebar's angle to securely fasten the handlebar press in place.

## 3.3 Install Rear Suspension



1. Loosen the installation screws on the frame.
2. Position the shock absorber in the center of the mounting bracket.
3. Secure the shock absorber in place by tightening the screws.

# FAST INSTALLATION

## 3.4 Install Front Fender



1. Loosen the screws at the mounting position of the front fender on the front fork.
2. Place the front fender onto the front fork. Fasten the front fender in place with screws and tighten them.

3. Check the clearance between the front fender and the front wheel, ensuring sufficient space to prevent any rubbing or contact between the tire and the fender.

## 3.5 Install Number Plate



1. Loosen the screws at the mounting position of the number plate on the front fork.
2. Place the number plate onto the front fork. Fasten the number plate in place with screws and tighten them.

3. Check the clearance between the front fender and the number plate, ensuring sufficient space to prevent any rubbing or contact between the plate and the fender.

# PREPARING FOR USE

## 4.1 Before Start-up

### 1. Inspect equipment

Check all bolts & nuts, brakes, engine, etc.

### 2. Refuel

Use the mixture of the gasoline and the two-stroke engine oil. The volume ratio is **50:1**. Use a clean and special fuel glass and grasp cap to shake for more than 30 seconds. Don't use mixture oil for more than 1 month.

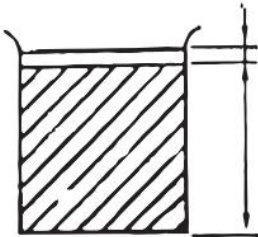

**50:1**

FC two-stroke engine oil: **90#** gasoline

### 3. Check and clean the air filter

The air filter must be often cleaned, or the polluted air filter will lower the output power of the engine. If the air filter is blocked by dust, use gasoline to clean the air filter, then dip in the oil, wring oil out, and put the air filter back.

# PREPARING FOR USE

## 4.2 Before Riding

1. Ensure all the exposed bolts and screws are tightened.
2. Raise the kickstand to its upright position.
3. When riding for the first time, wait 3-5 minutes after pulling the pull start to allow the engine to fully warm up before riding.
4. Make sure the engine is running.
5. Put one foot on the deck of the motorcycle. While pushing off with the other foot, gently rotate the THROTTLE toward the rider, on the right side of the handlebars. The bike will begin to move on its own power.
6. Control the speed by rotating the hand throttle either towards the rider or away.



# PREPARING FOR USE

## 4.3 Starting the Dirt Bike

1. Before starting, make sure to fill the fuel tank with the **recommended fuel grade**, maintaining a minimum fuel level of at least **two-thirds** of the tank's total capacity.
2. Depress the vent valve to release any residual air from the fuel line until **no air bubbles are visible in the fuel line**. Ensure the valve is filled with fuel, then depress it **3-5 times**. This valve is typically located below the carburetor.
3. Confirm that the kill switch is in the "ON" position.
4. Shift the choke lever to the "OFF/Cold Start" position.
5. Slowly pull the pull start to its maximum length about three times to establish the proper pull length. **Then, pull the pull start rapidly until the engine roars. The bike will automatically shut off.** Return the choke lever to the "ON/Warm Start" position and pull the pull start again. The engine will start. If it stalls, repeat steps 4-5 until the engine starts.
6. Once the engine starts, allow it to idle for **2-3 minutes** to ensure it reaches the optimal operating temperature.

### Important Note

- a. After prolonged operation under heavy load, the engine may shut down due to overheating. In such cases, park the vehicle and allow it to cool for at least 15 minutes before attempting to restart. When restarting, begin from step 2.
- b. When rapidly pulling the starter handle, be sure not to exceed the maximum pull length to prevent damage.
- c. During the vehicle startup process, avoid maintaining continuous maximum throttle, as it may hinder the starting process.



# OPERATION

## 5.1 Operation and Running

The bike is packed in a cardboard carton. After unpacking. Very smooth and perfect function of the Bowden cable throttle and both brakes. Fill the fuel tank with fuel. (**Gas-oil mix 50:1**).

Failure to use the proper oil mix ratio will result in Engine damage which you will be responsible for. Keep a low speed when turning otherwise it can cause losing control.

The bike is unsuitable for public road use. It does not comply with reasonable safety standards. Unsafe and careless use of a bike can result in serious injuries. The driver can minimize the potential risks by wearing safety equipment. The driver must wear a safety helmet, goggles, gloves, elbow pads, knee pads, and athletic footwear. The bike can't be used on wet, icy, or oily surfaces.

Avoid uneven surfaces and obstacles, Drive with two hands on the handlebars.

## 5.2 Operating Procedures

### **WARNING!**

Permanently shut the engine off before refueling.  
Slowly open the fuel tank, so that possible over-pressure disappears.

Before fueling, clean the tank cap area carefully, to ensure that no dirt falls into the tank. Make sure that the fuel is well-mixed by shaking the container.

Tighten the fuel cap carefully after fueling.  
Always move the unit at least 10 feet from the fueling area before starting.

# CONTROLS

## 6.1 Braking

1. To brake, release the hand throttle and depress the hand brake levers (on the left and right side of the handlebars).
2. Gradually decrease the engine speed to idle and turn off the kill switch on the handlebar. This will turn the engine OFF.

## 6.2 Braking System

The motorcycle uses a disc/caliper braking system activated by a hand brake lever on the left and right side of the handlebar.

Squeezing the hand brake lever with your left hand activates the rear brake. Make sure to release the **HAND THROTTLE GRIP** when engaging the brakes.

Practice braking on a smooth, dry surface to get used to the feel of the braking system. Braking distance is affected by wet conditions and loose and uneven riding surfaces.

## 6.3 Stopping

Stop the throttle handle or pull down the switch in an emergency. But in normal status, please operate as follows:

1. Reduce the gasoline engine to the lowest speed and run for 3-5 minutes.
2. Pull down the stop switch and stop the engine.

# ADJUSTMENT

## 7.1 Carburetor Adjustment



Never start the engine without the complete clutch cover assembled! Otherwise, the clutch can come loose and cause injuries.

When the engine is tested at the factory, the Carburetor is basically adjusted. Further adjustment may be required occasionally, depending on climate and altitude.



When the engine is idling, under no circumstance should your motorcycle be moving.

If the motorcycle continues to move after idle speed adjustment, contact the service center.

## 7.2 Brake Adjustment

The Brakes on the motorcycle should come fully adjusted from the factory. However, it may be necessary to change the brake from time to time.

1. With one hand, depress the brake caliper using your thumb and forefinger.
2. With the other hand, adjust the tension screw on the brake line.
  - a. Turn the tension screw clockwise to loosen the brake.
  - b. Turn the tension screw counterclockwise to tighten the brake.

### Squeaky Brakes

The brakes may squeak before they are broken in. This is normal and will not affect the function or performance of the brakes. With continued use, the squeak should go away.

# ADJUSTMENT

## 7.3 Chain Adjustment

The chains will come adjusted from the factory. However, it may be necessary to adjust the sprockets from time to time. **The chain must be well aligned with the sprockets otherwise they may start to rub and chafe. Which will result in a shortened chain life.**



### How tight should the chain be?

If the chain is skipping or jumping on the pulley teeth, it is too loose and may be harmful.

If the chain is making a humming sound when the wheel is turning, it is too tight and may cause the chain to snap.

The correct tension is achieved by adjusting the chain from its loose position to when it becomes lightly tense.

### To tighten the chains:

1. Slightly loose the two Axle bolts on both sides of the rear wheel. Then slowly adjust the two chains.
2. Occasionally rotate the rear wheel to make sure the chain is aligned.
3. Finally lock and tighten the rear axle bolts prior to riding.

# MAINTENANCE AND STORAGE

## 8.1 Maintenance Schedule

Proper care of your motorcycle will ensure optimal performance and a longer life span. The following are a few maintenance suggestions that will keep your motorcycle running in top condition:

### Daily Maintenance:

Perform each time you ride your motorcycle.  
Clean fuel leakage or air leakage.  
Check that all nuts and bolts are securely tightened.

### Weekly/ Monthly Maintenance:

Check the pull starter, especially the cord and return spring.  
Remove the spark plug and check the electrode gap.  
Adjust it to 0.6mm, or change the spark plug.  
Clean the cooling fins on the cylinder head and check that the air intake at the starter is not clogged.  
Clean the air filter.

## 8.2 Storage

If the bike hasn't used for a long time, it must be maintained as:

1. Remove the fuel in the tank and in the carburetor, close the chock totally, and draw the starter 3-5 times.
2. Take down the sparking plug, add certain engine oil from the spark plug hole into the cylinder, and draw the starter 2-3 times to move the piston to the top dead center, then install the spark plug.
3. Use the soft cloth with engine oil to clean the surface of the engine, smear wax on the frame, and put the engine in a dry and windy place for the next use.



# TROUBLE SHOOTING

## 1. Fail to start.

- 1) . Gasoline mixed with water, please replace it.
- 2) . The spark plug has accumulated carbon or has been broken through.
- 3) . Poor contact of the high-voltage wire with the spark plug.

## 2. The engine can start. But can't run speedily.

- 1) . The choke is open totally or not.
- 2) . The ratio of the engine oil and the gasoline normal or not.
- 3) Maybe there is water in the gasoline.

## 3. The gasoline engine can run but has not enough power.

- 1) Maybe the air filter is blocked by dust.
- 2) Maybe the cylinder exhaust and the muffler are blocked by accumulated carbon.
- 3) The piston, the piston rings, and the cylinder have been badly worn out.
- 4) Maybe the fuel strainer is blocked by dust.
- 5) The body or the top of the shaft has oil leakage and air leakage.

## 4. The gasoline engine stops suddenly when running.

- 1) Run out of gasoline.
- 2) The high-voltage wire drops.
- 3) The spark plug has accumulated carbon or has been broken through.
- 4) The fuel strainer is blocked by dust.
- 5) Maybe there is water in the gasoline.
- 6) The air hole of the tank lid is blocked by dust.

## 5. Can't stop the engine.

The stopping wire of the switch is an open circuit.

**Thank You for purchasing this motorcycle.**

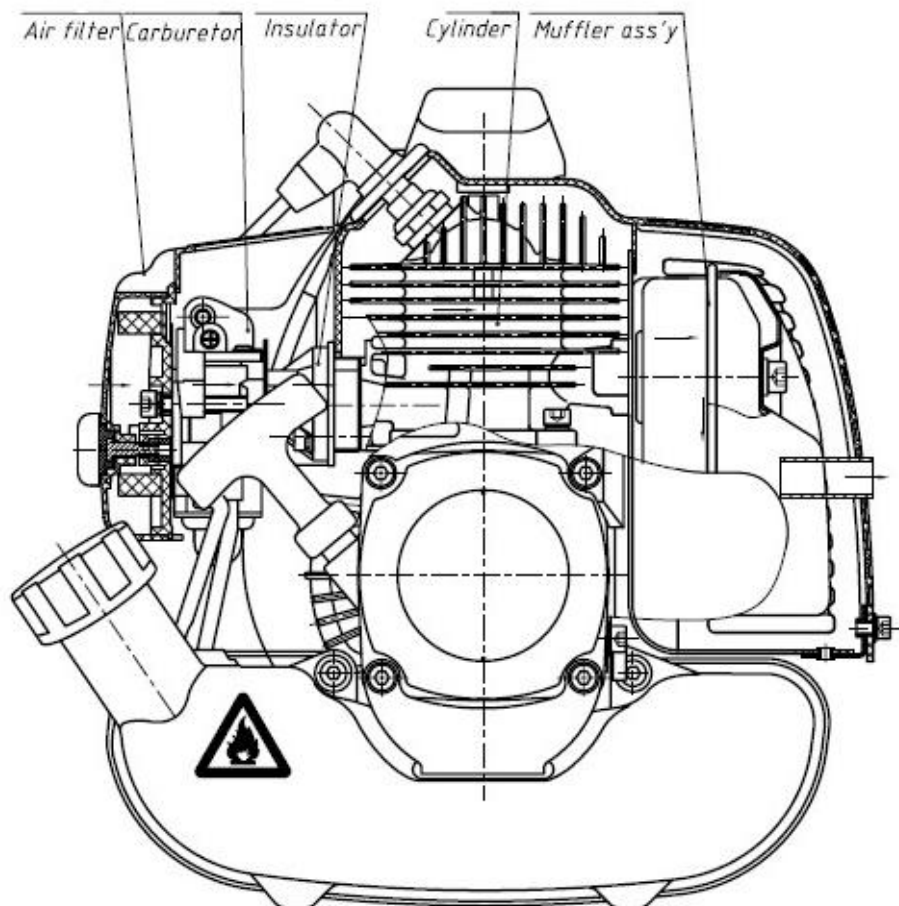
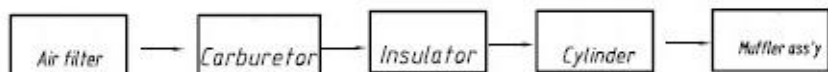

*The exhaust gas is discharged after the second combustion of the catalyst.*



To keep the performance good, the motorcycle should be checked and maintained at certain interval. The meanings of capital in following table are:

I: Inspection, including check, clean, lubricate, refuel, repair or replacing if necessary.

A: Adjusting

C: Cleaning

R: Replacing

T: Tightening

Items	Maintenance period	Odometer (km)						Everyday check before riding 每次骑车前进行日常检查
		750	3000	6000	9000	12000	15000	
**Spark Plug			I	R	I	R	I	
**Fuel System			I	I	I	I	I	
*Idle Speed			A	A	A	A	A	
*Engine Bolt			I	I	I	I	I	
*Gear Oil			R	R	R	R	R	
*Fuel Filter			R	R	R	R	R	
*Air Cleaner			C	R	C	R	C	
*Drive Chain			IL	IL	IL	IL	IL	
*Cooling System			I	I	I	I	I	
Engine Mount			I	I	I	I	I	
Fuel Line			I	I	I	I	I	
Throttle Operation			I	I	I	I	I	
Brake Shoes/Pad Wear			I	I	I	I	I	
Brake System			I	I	I	I	I	
Clutch			I	I	I	I	I	
Suspension			I	I	I	I	I	
Nuts, Bolts, Fasteners			I	I	I	I	I	
Wheel/Trye			I	I	I	I	I	
Steering System			I	I	I	I	I	
Governor			A	A	A	A	A	
Injector Lash			A	A	A	A	A	





## Warranty

### BKAA GROUP CORPORATION– EMISSION CONTROL SYSTEM WARRANTY

#### YOUR WARRANTY RIGHTS AND OBLIGATIONS

The emission control system warranty period for this vehicle begins on the date the vehicle is delivered to the ultimate purchaser and each subsequent purchaser other than an authorized dealer, or the date it is first used as a demonstrator, lease, or company vehicle, whichever comes first and continues for 5,000 km or 30 months, whichever comes first, provided there has been no abuse, neglect or improper maintenance of your vehicle. Where a warrantable condition exists, the dealer will repair your vehicle at no cost to you, including diagnosis, parts and labor. If an emission-related part on your vehicle is defective, the part will be repaired or replaced by the dealer. This is your emission control defects warranty.

#### OWNER' S WARRANTY RESPONSIBILITIES

As the vehicle owner, you are responsible for the performance of the required maintenance. You should maintain a record of all maintenance performed on your vehicle and retain all receipts covering maintenance on your vehicle. You may not be denied a warranty claim solely because of your failure to ensure the performance of all scheduled maintenance or lack of maintenance records or receipts. You are responsible for presenting your vehicle to an authorized dealer as soon as a problem exists. The warranty repairs should be completed in a reasonable amount of time, not to exceed 30 days. As the vehicle owner, you should be aware that you may be denied your warranty coverage if your vehicle or a part has failed due to abuse, neglect, improper maintenance, or unapproved modifications.

#### WARRANTY COVERAGE

The Importer warrants to the ultimate purchaser and each subsequent purchaser that the new 2024 vehicle, including all parts of its emission-control system, meets two conditions:

- It is designed, built, and equipped so as it conforms at the time of sale to the ultimate purchaser with the applicable requirements of the United States Environmental Protection Agency; and
- It is free from defects in material and workmanship that may keep it from meeting these requirements.

Your emission control system warranty covers components whose failure would increase an engine's emission, including electronic controls, fuel injection system, carburetor, the ignition system, catalytic converter, or any other system utilized in this vehicle to control emission if it is originally equipped. Also included may be hoses, connectors and other emission-related assemblies. Replacing or repairing other components (including parts, labor, and other costs) not covered by this emission control system warranty or the standard warranty is the responsibility of the owner.

Coverage of repairs under this warranty applies only when repairs are completed at an authorized dealer or repair facility. The importer will not cover repairs performed outside of an authorized dealer or repair facility, except in an emergency situation. The use of replacement parts not equivalent to the original parts may impair the effectiveness of your vehicle's emission control system. If such a replacement part is used and an authorized dealer determines it is defective or causes a failure of a warranted parts, your claim for repair to bring your vehicle into compliance with applicable standards may be denied.

If an emergency situation exists when a warranted part or a dealer is not reasonably available to the owner, repairs may be performed at any available service establishment, or by the owner, using any replacement parts. The importer shall reimburse the owner for the expenses, diagnostic charges, not to exceed the importer's suggested retail price for all warranted parts replaced and labor charges based on the importer's recommend time allowance for the warranty repair and the geographically appropriate hourly labor rate. The owner may reasonably be required to keep receipts and failed parts in order to receive compensation.

This Emission Control System Warranty is in addition to the standard Limited Warranty.



## LIST OF EMISSION RELATED PARTS

Part Name	Part Number	Part Manufacturer
<b>Emission Control System</b>		
Catalytic Converter	DP11181	Nanjing Depurate Catalys CO., Ltd.
<b>Fuel System</b>		
Fuel Tank	DC0.9-01 DC1.0-01 DC1.2-01 DC1.6-01 DC2.2-01	Zhejiang Boge Industry& Trade Co., Ltd.
Fuel Tank Cap	D02	Zhejiang Boge Industry& Trade Co., Ltd.
Fuel Tank Gasket	Gaskets has an exposed surface area of less than 1000mm square.	
Fuel Line	EPA-TY-115	Xiamen Typesom Rubber And Plastic Industrial Co., Ltd.
Carburetor Assembly	2619-4	Zhejiang Ruixing Carburetor Manufacturing CO., LTD.
<b>Ignition System</b>		
CDI	1E40F-E	Shandong Zhongci Power Machinery CO., LTD.
Coil	D05	Shandong Zhongci Power Machinery CO., LTD.
Spark Plug	L8RTC	Nanjing SW Automobile Electrical Appliance CO., LTD.
<b>Crankcase Emission Control System</b>		
Air Cleaner	D06	Linyi Woerma Machinery CO., LTD.

## EXCLUSIONS AND LIMITATIONS

This warranty does not cover the following:

- Failures or malfunctions of the emission control systems caused by abuse, alteration, accident, misuse, the use of leaded gasoline.
- Replacement of expendable maintenance items unless they are original equipment defective in material or workmanship under normal use, and the first required replacement interval for the item has not been reached. Expendable maintenance items include but not limited to spark plugs, filters, coolant, lubricants, gaskets, hoses and belts.
- Replacement of parts and other service and adjustments for required maintenance.
- Any vehicle equipped with an odometer or hour meter where the reading is altered so that actual mileage cannot be readily determined.
- Repairs or replacement as a result of:
  - Accident
  - Misuse
  - Use of replacement parts or accessories not conforming to the original specifications which adversely affect performance
- Physical damage, corrosion, or defects caused by fire, explosions or similar causes beyond the control of the importer
- Failures not caused by a defect in material or workmanship.

Use of the vehicle in any type of competitive racing or related events immediately and completely voids this and all other warranties.

## CONTACT

Modification of any emission related parts including but not limited to parts as indicated below, may void this Warranty and Manufacturer will not be responsible for any damage therefore incurred to the vehicle and Owner of the vehicle may be subject to civil penalty up to \$4619 for each engine or piece of equipment in violation per US EPA 42 USC 7522(a)(3)(A) and (B)1> Engine, and engine running idle speed;

- 1> Catalyst converter;
- 2> Carburetor (if applicable);
- 3> Speed limit-governing devise.

No dealer is authorized to modify this Emission-Related Warranty. If you have any questions regarding your warranty rights and responsibilities, you should contact BKAA GROUP CORPORATION at 909-510-0308 (or you can write to INFO@BKAA.LIFE).

## Important Notice

---

### **\*\*Contact Information\*\***

If you encounter any issues during use, please cease operation immediately and refer to the manual or contact our customer service team.

- Customer Service: 833-970-3777 (Toll Free)
- Email: [csr@frptoys.com](mailto:csr@frptoys.com)

Thank you for choosing our product. We wish you a delightful user experience!



**Disassembly and Assembly Video Instruction**