

# All the parts you need

5 panels →

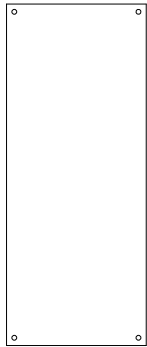

1 cushion →

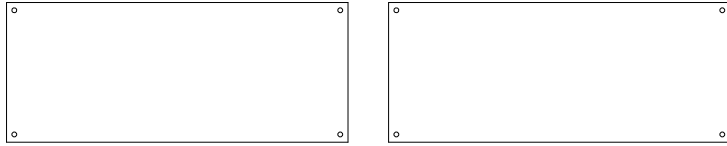
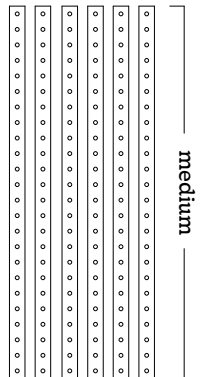
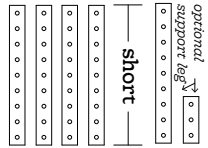
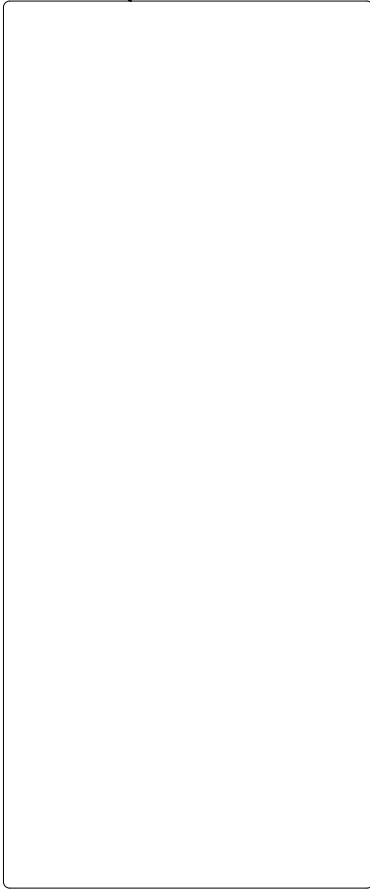

long

medium

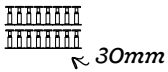
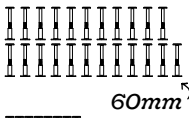
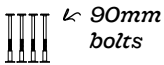

3 sizes of rails ↗



## Lorenza Daybed

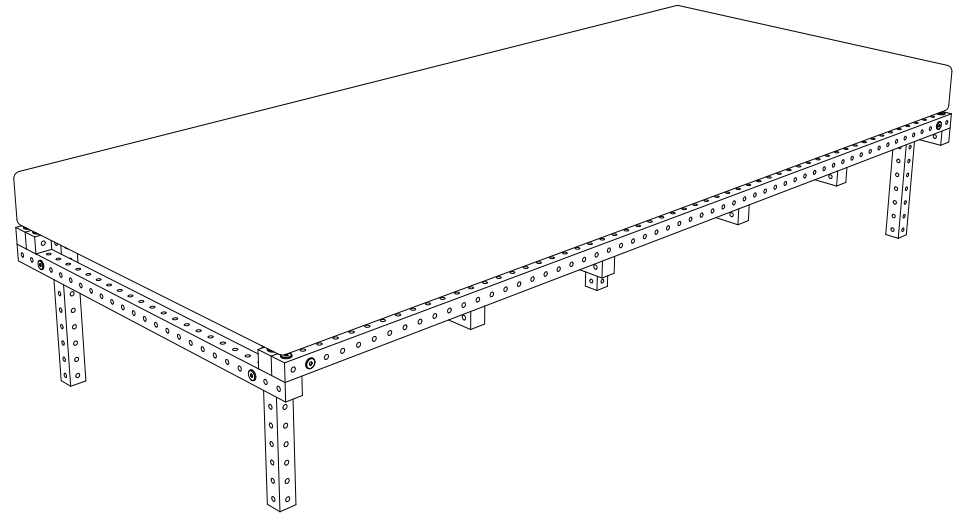

### Assembly Instructions

Assemble the Legs → Complete the Base → Add the Panels → Tighten Up



@loose\_parts  
assemble@loose\_parts  
www.loose\_parts

Let's start assembling!

### Step 1

Assemble the base

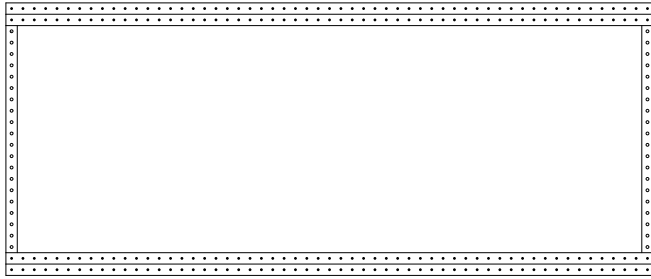

Grab the long rails and lay them side by side on top of the medium rails.

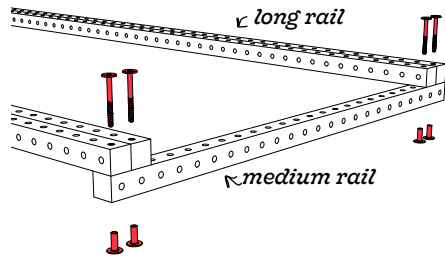

Attach using the 60mm bolts.\*

\*Don't tighten down the bolts too much, we'll go back and do that at the end.

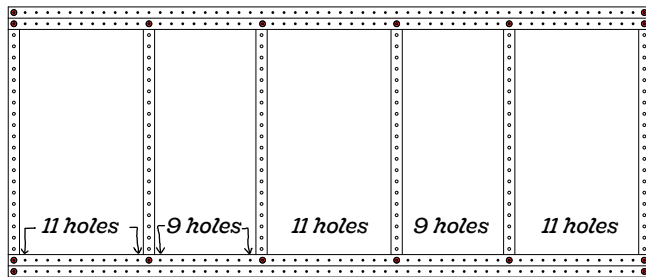

Attach the remaining medium rails to the inner long rail, counting the holes to determine the spacing between each rail.

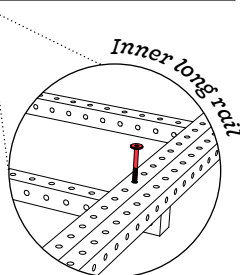

### Step 2

Attach the legs

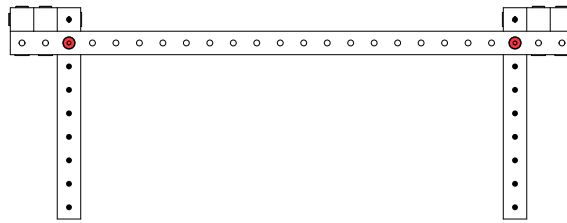

Attach the short rail to inside of medium rail with 60mm bolt

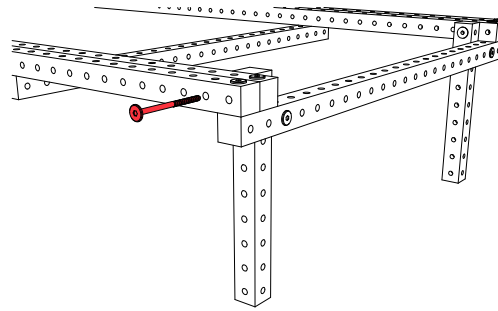

Use the 90mm bolt to secure the short rail to the two long rails.

Option to add a support leg to the center of the base for extra stability. Attach remaining short rail and support piece to medium rail, overlapping all 3 rails to create a tri-joint.

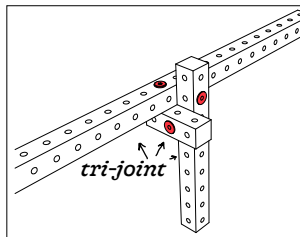
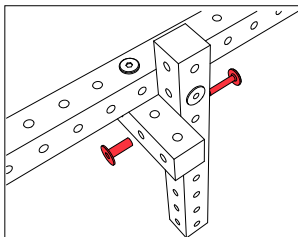
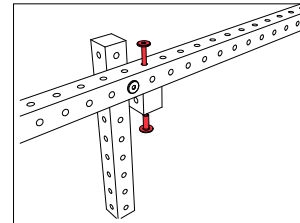
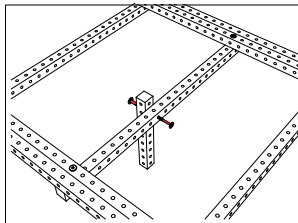

### Step 3

Add the Panels

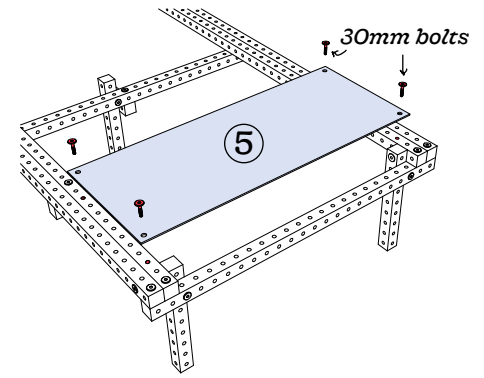

Attach panel 5 to the 3rd hole of inner long rail using the 30mm bolts. Repeat for panel 3 and 1.

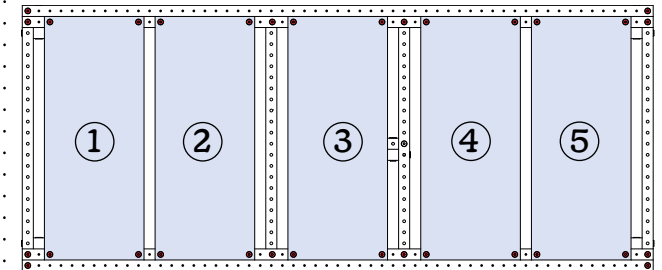

For panel 2 and 4 you will need to loosen the 60mm bolt used to attach the rail and pass it through the panel. Use the 30mm bolt for the other two holes.

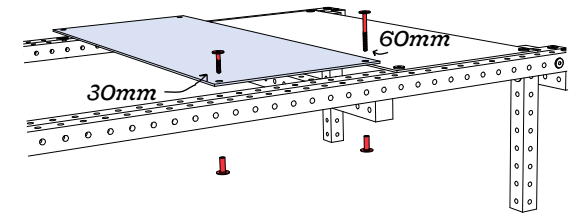

### Step 4

Tighten Up

Your bed is now complete. Go ahead, tighten down all the bolts and give yourself a high five!

