

# All the parts you need

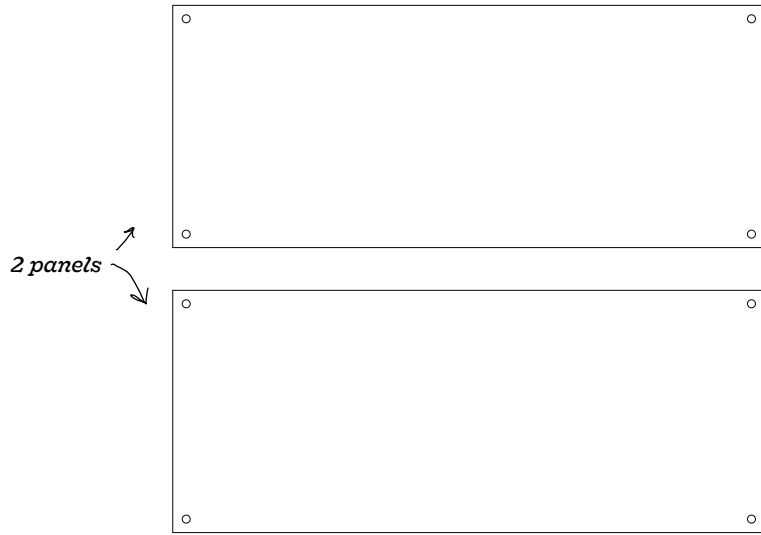

3 sizes of rails

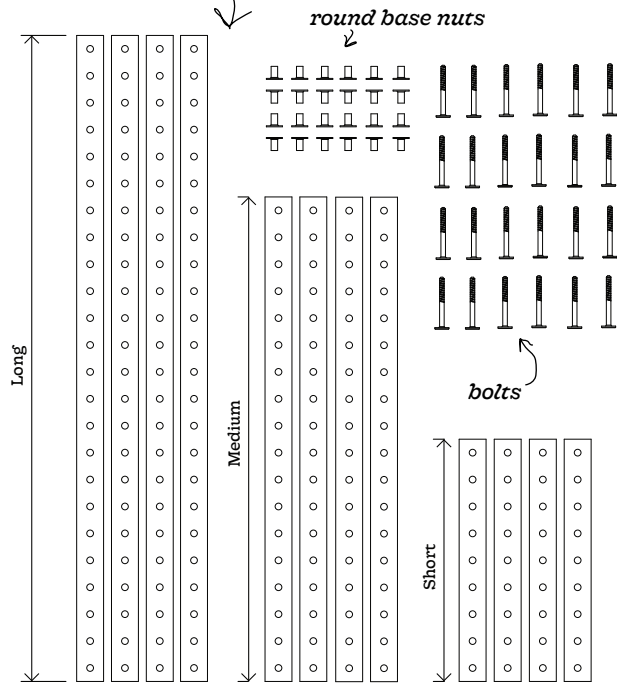

# Berta Bookcase

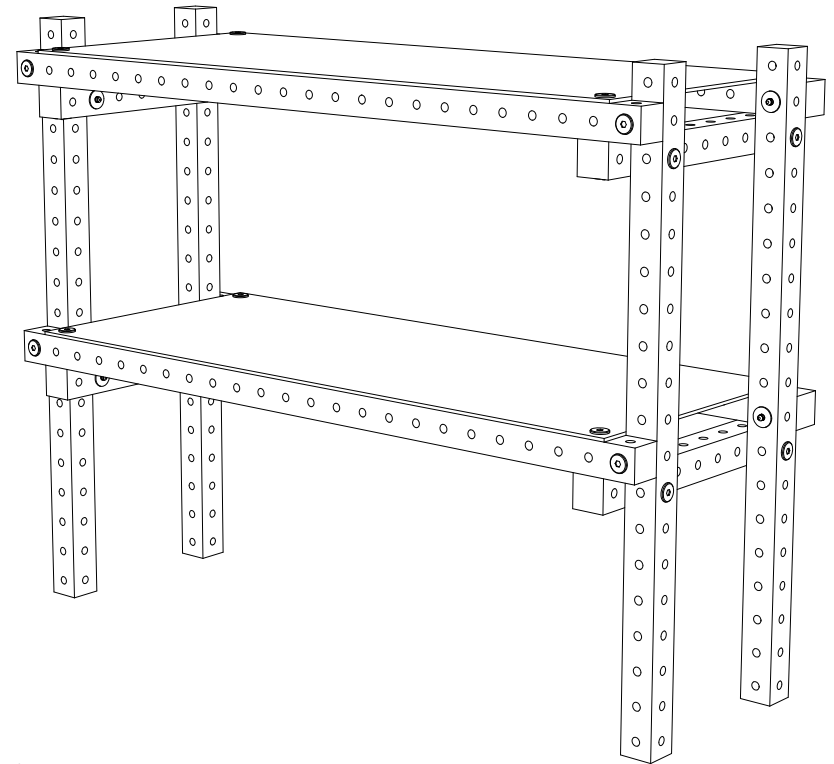

## Assembly Instructions

Assemble the Legs → Complete the Base → Add the Panels → Tighten Up



@loose\_parts  
assemble@loose.parts  
www.loose.parts

Let's start assembling!

### Step 1

Assemble the Legs

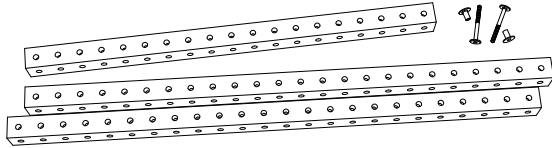

Grab the long and medium rails, bolts & nuts.

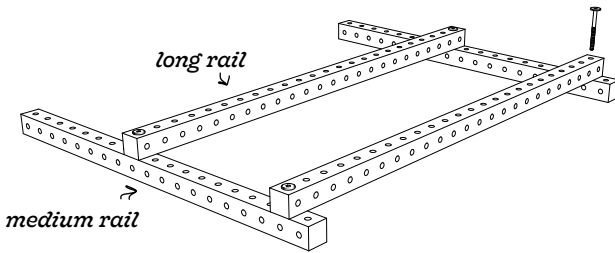

Attach the long rail to the medium rail according to desired shelf height.\* Repeat so you have a set of two legs.

\*Don't tighten down the bolts too much, we'll go back and do that at the end.

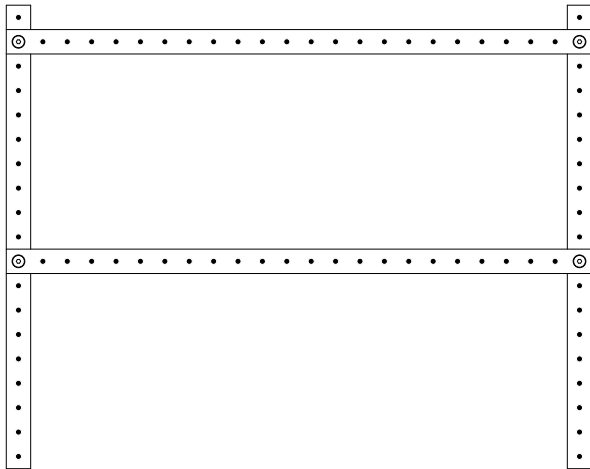

Counting the holes from the bottom helps ensure that you attach your shelves level.

Face legs towards each other, keeping the long rail on outside of both sides.

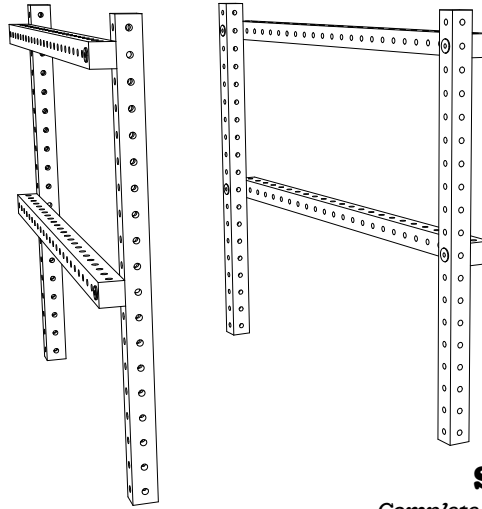

### Step 2

Complete the Base

Attach short rail to inside of the medium rail, overlapping all 3 rails to create a tri-joint. Repeat for second shelf and on other side.

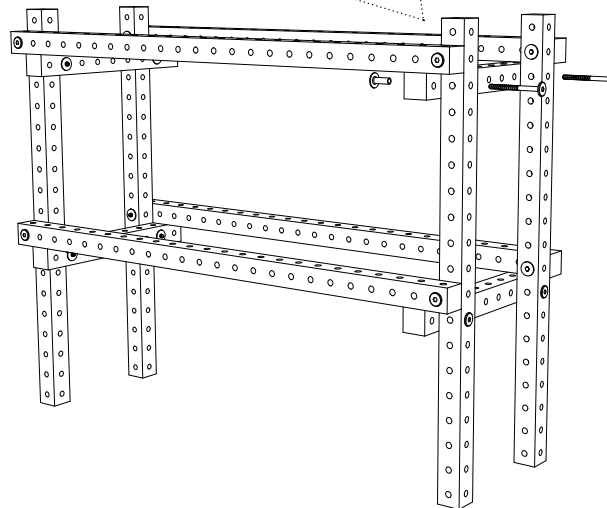
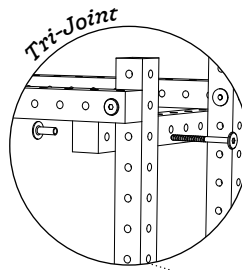

### Step 3

Add the Panels

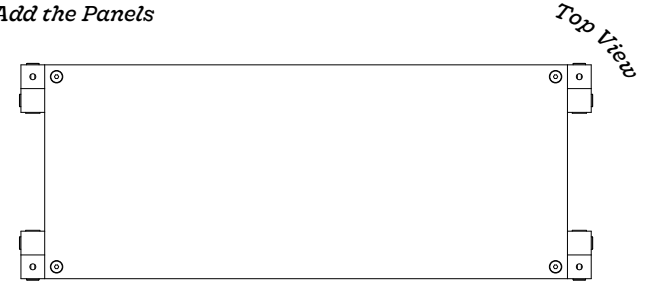

From the top, attach panel to long rail on all four sides. Repeat on second shelf.

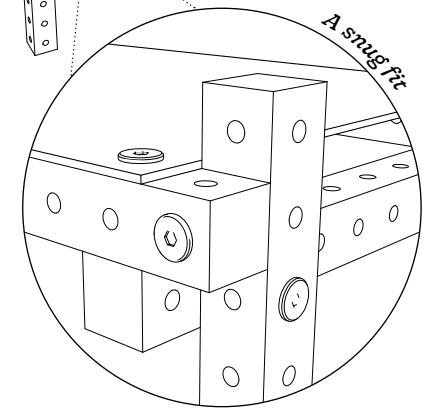
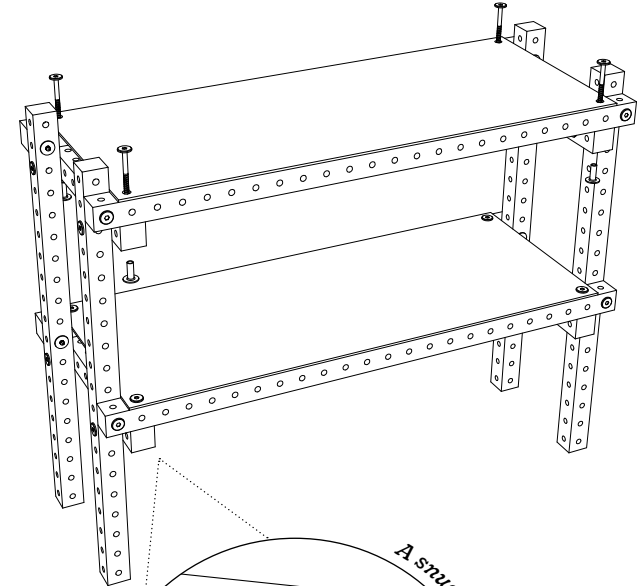

### Step 4

Tighten Up

Your table is now complete. Go ahead, tighten down all the bolts and give yourself a high five!