

## Assembly Instructions for OAK Table

### All the parts you need

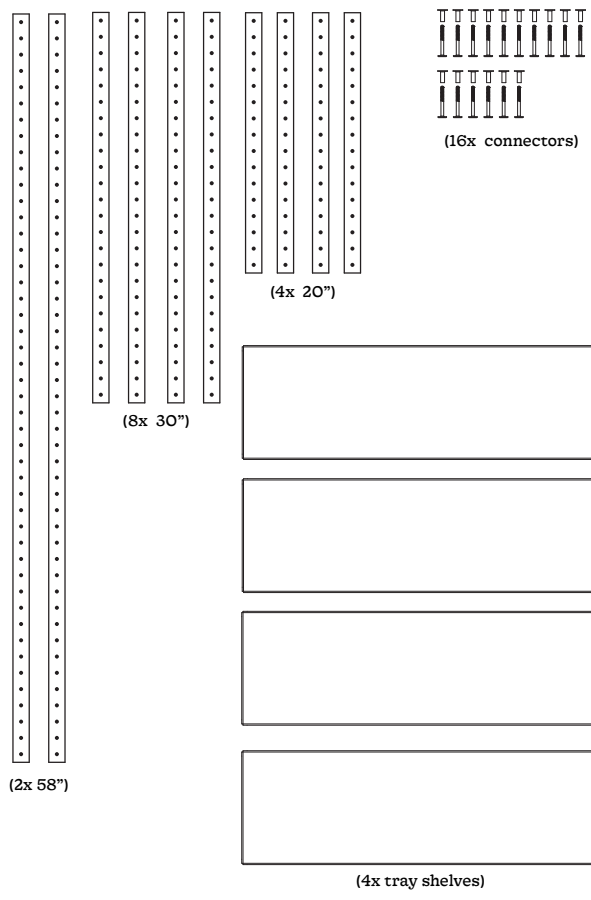

Attach one medium rail perpendicular to other two rails according to desired table height. \* Repeat so you have a set of two legs.

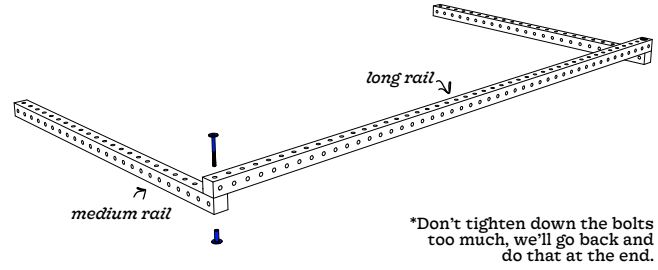

Face legs towards each other, keeping the medium rail on outside of both sides.

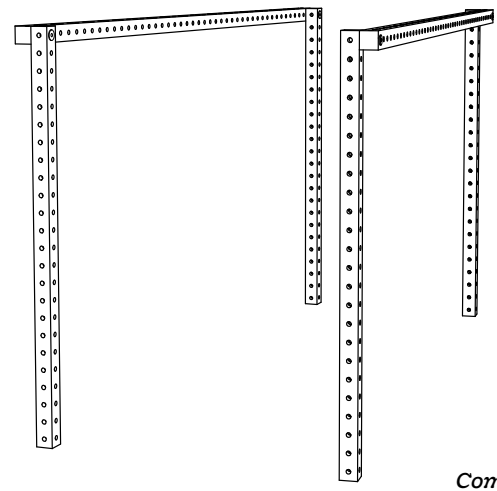

### Step 2 Complete the Base

Attach the 20" (short) rail to inside of medium rail. Repeat on other side of table.

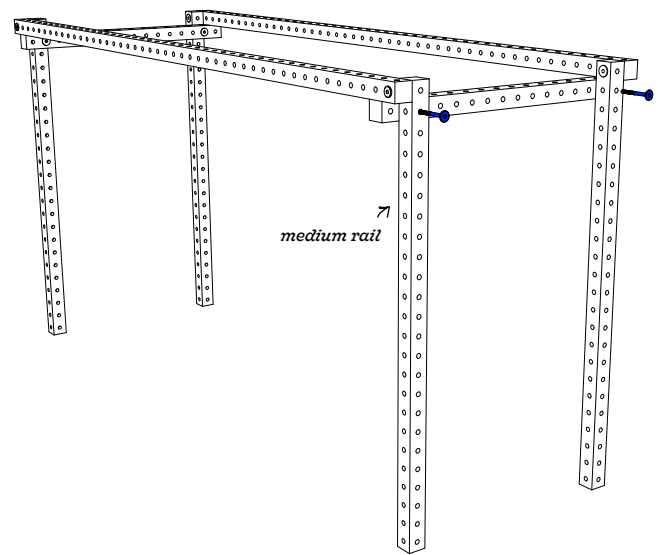

Attach medium rail to short rail, overlapping all 3 rails to create a tri-joint. Lastly, attach remaining short rails to center of table.

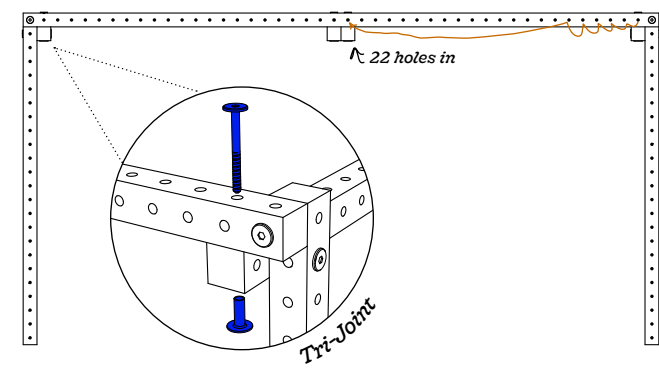

### Step 3 Add Panels

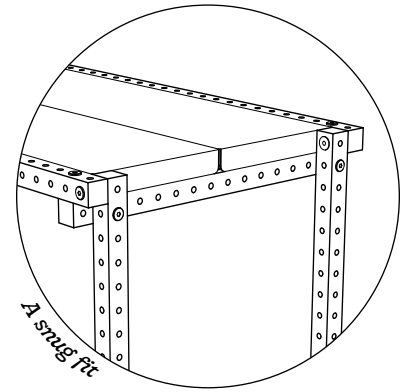
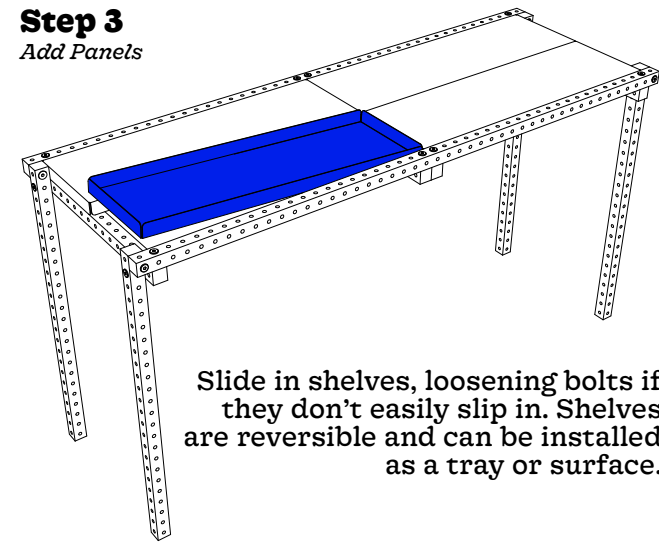

### Step 4 Tighten Up

Your Loose Parts is now complete. Go ahead, tighten down all the bolts and give yourself a high five!

Let's start assembling!

### Step 1 Assemble the Legs

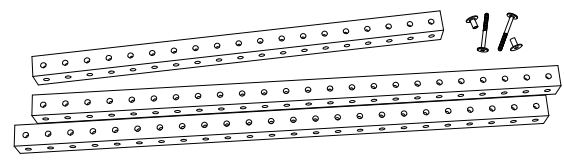

Grab the 58" (long) and 30" (medium) rails, bolts & nuts.

