

Assembly Instructions
for
OAK Small Table

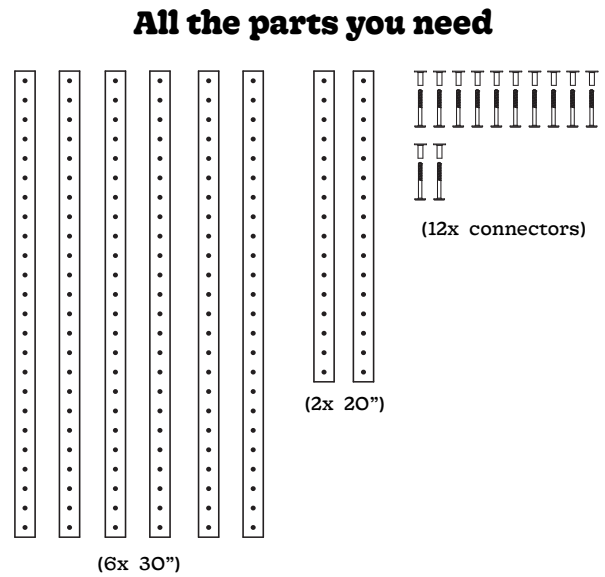

Attach one medium rail perpendicular to other two rails according to desired table height. * Repeat so you have a set of two legs.

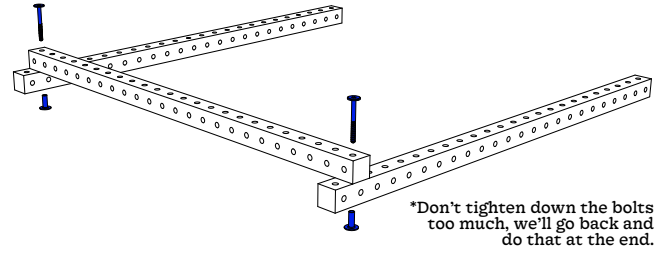

Face legs towards each other, keeping the perpendicular rail on outside of both sides.

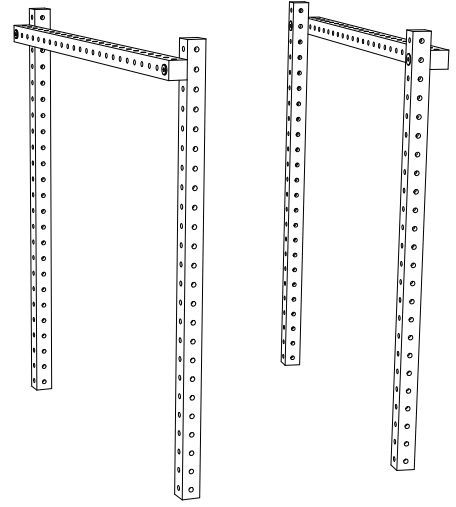

Step 2
Complete the Base

Attach the 20" (short) rail to inside of medium rail. Repeat on other side of table.

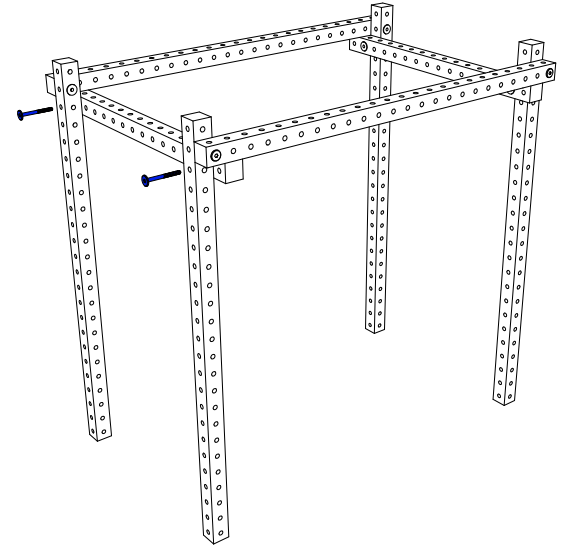

Attach medium rail to short rail, overlapping all 3 rails to create a tri-joint.

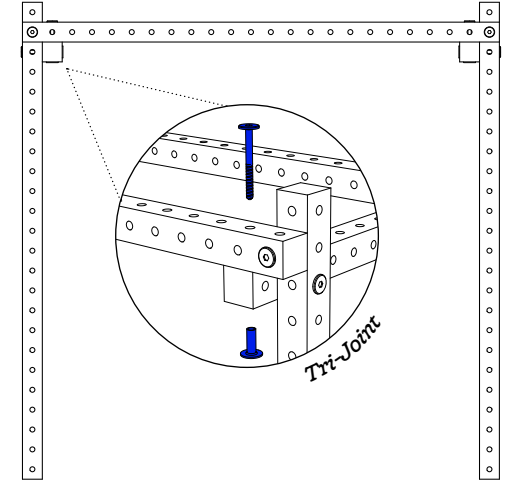

Step 3
Add Panels

Slide in shelves, loosening bolts if they don't easily slip in. Shelves are reversible and can be installed as a tray or surface.

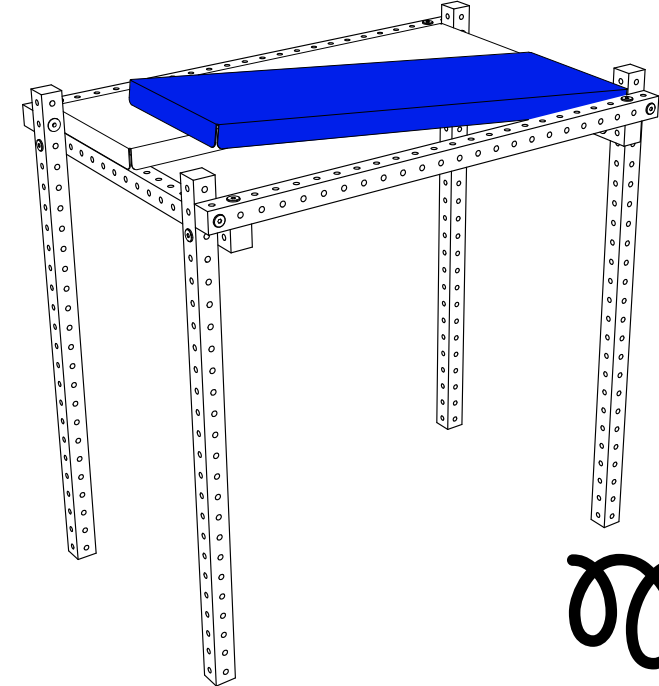

Step 4
Tighten Up

Your Loose Parts is now complete. Go ahead, tighten down all the bolts and give yourself a high five!

Let's start assembling!

Step 1
Assemble the Legs

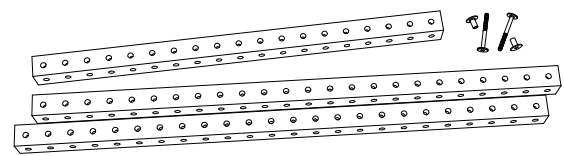

Grab the 30" (medium) rails, bolts & nuts.

