

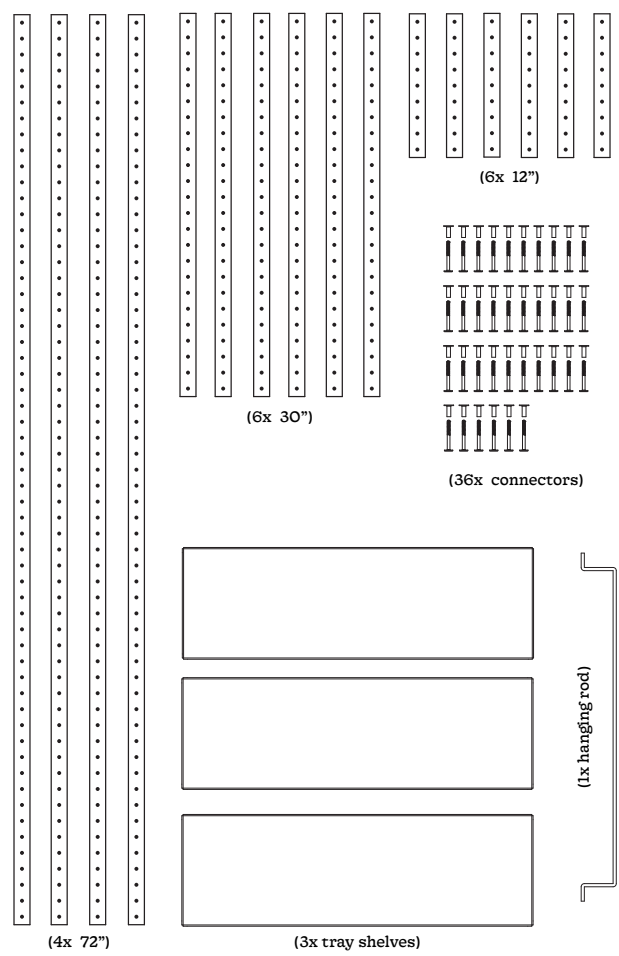

Assembly Instructions for **OAK Narrow Garment Rack**



All the parts you need



Let's start assembling!

Step 1
Assemble the Legs

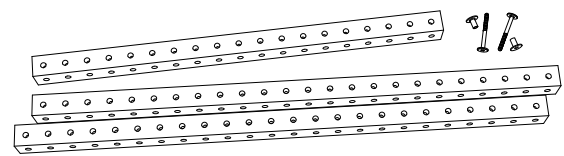

Grab the 72" (long) and 30" (medium) rails, bolts & nuts.

Attach the medium rail to the long rail according to desired shelf height.* Repeat so you have a set of two legs.

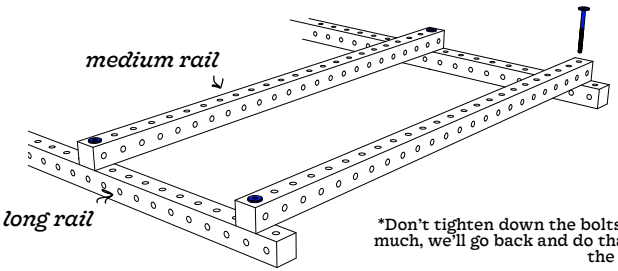

Face legs towards each other, keeping the medium rail on outside of both sides.

*Don't tighten down the bolts too much, we'll go back and do that at the end.

Step 2
Complete the Base

Attach the 12" (short) rail to inside of the long rail. Repeat for the rest of the shelves and on other leg.

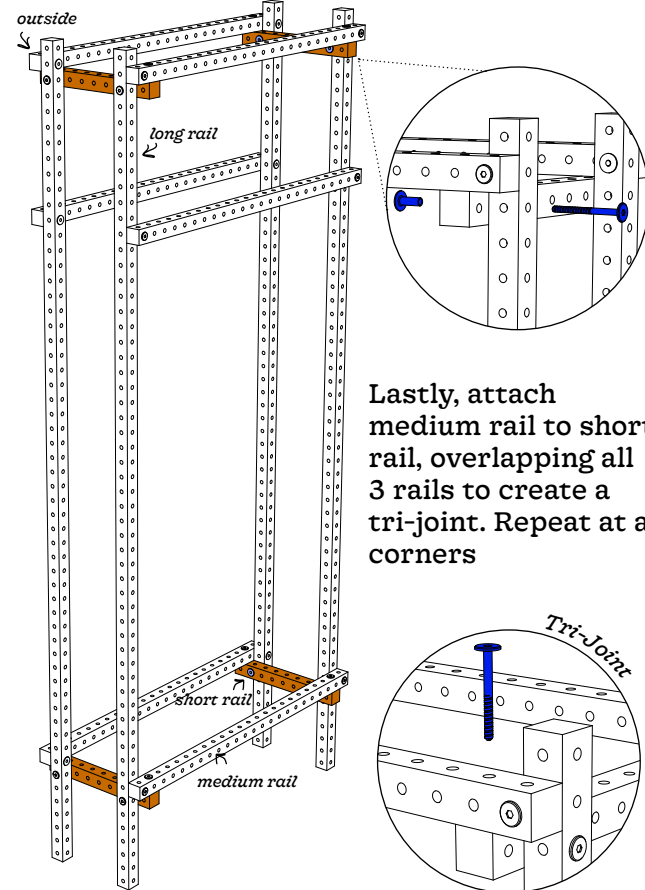

Lastly, attach medium rail to short rail, overlapping all 3 rails to create a tri-joint. Repeat at all corners

Step 3
Add Hanging Rod and Panels

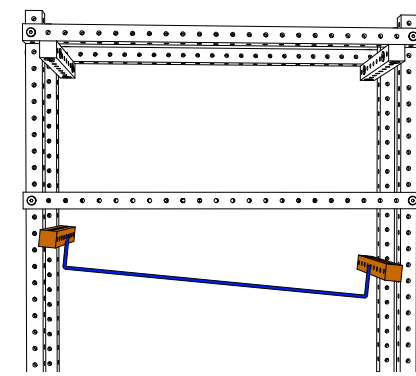

The hanging rod is sandwiched between the two remaining short rails before attaching to the rack.

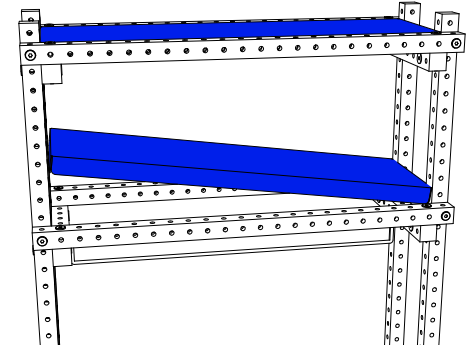

Slide in shelves, loosening bolts if they don't easily slip in. Shelves are reversible and can be installed as a tray or surface. Repeat for other shelves.

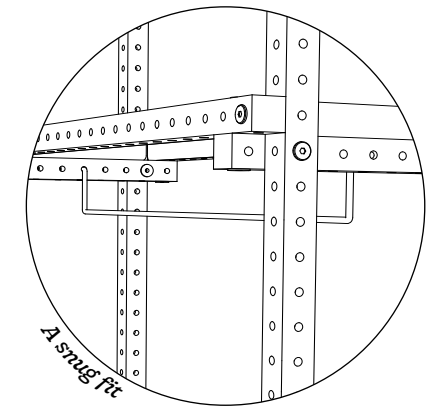

Step 4
Tighten Up

Your Loose Parts is now complete. Go ahead, tighten down all the bolts and give yourself a high five!