

All the parts you need

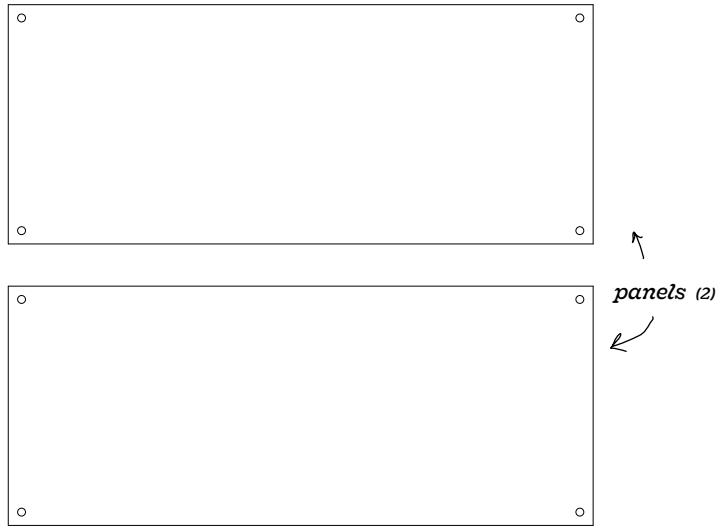

Mary Coffee Table

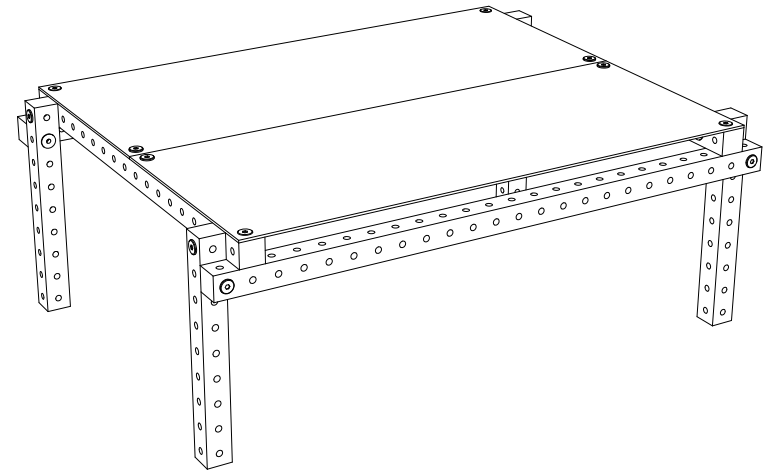
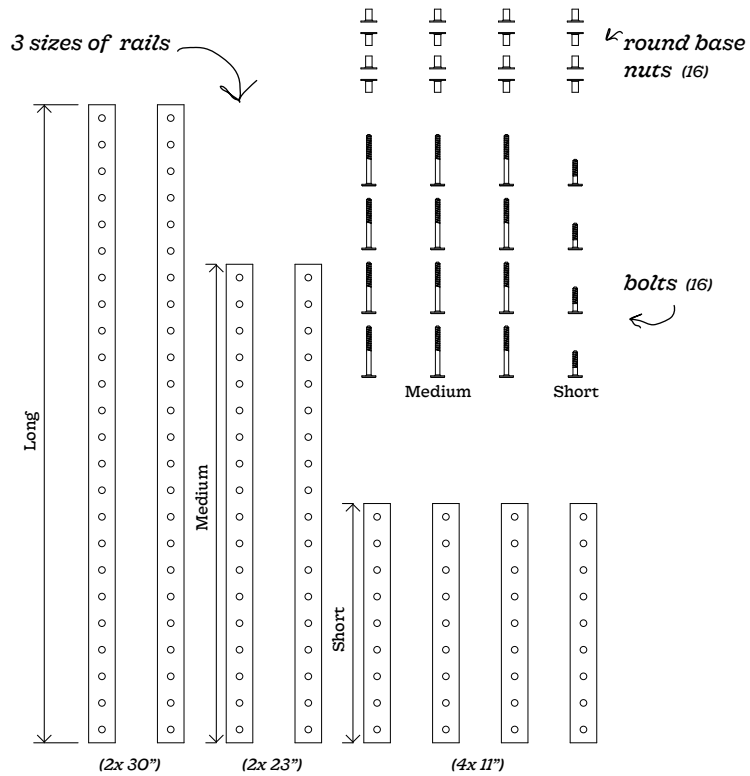

Assembly Instructions

Assemble the Legs → Complete the Base → Add the Panels → Tighten Up



Let's start assembling!

Step 1

Assemble the Legs

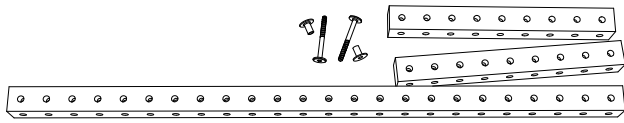

Grab the long and short rails, medium bolts & nuts.

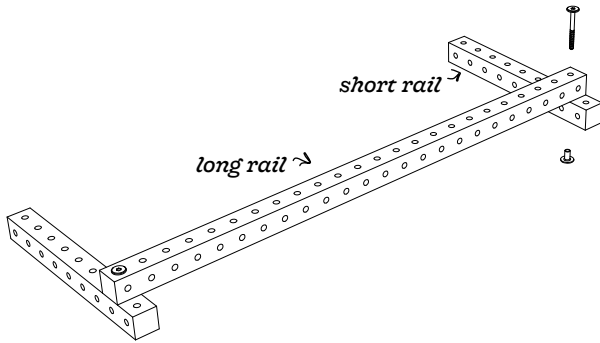

Attach the long rail to the short rail second hole down from the top. *

Repeat so you have a set of two legs.

*Don't tighten down the bolts too much, we'll go back and do that at the end.

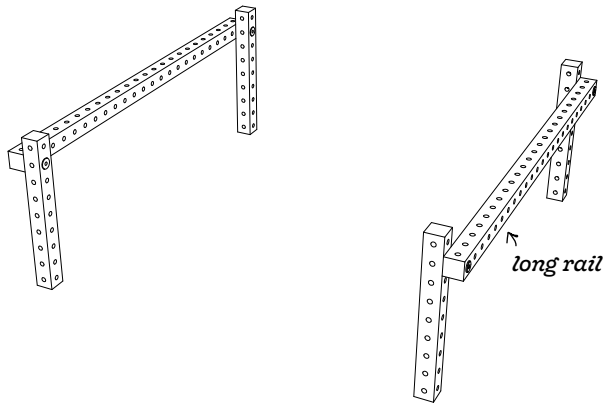

Face legs towards each other, keeping the long rail on the outside of both sides.

Step 2

Complete the Base

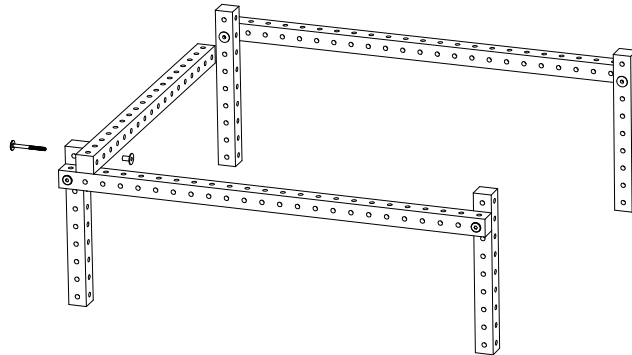

Stack the medium rail on top of the long rail, attaching to the inside of short rail so all three overlap creating a tri-joint.

Repeat on other side

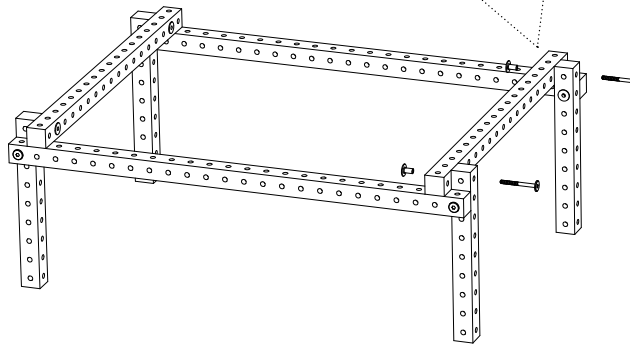
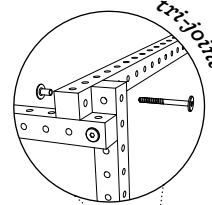

Step 3

Add the Panels

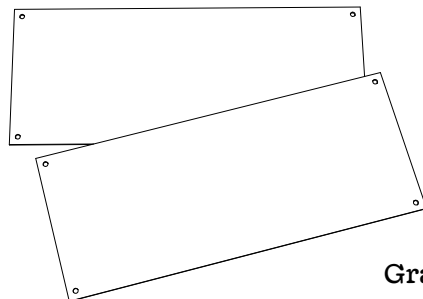

Grab your panels

bolt panel to outside corner

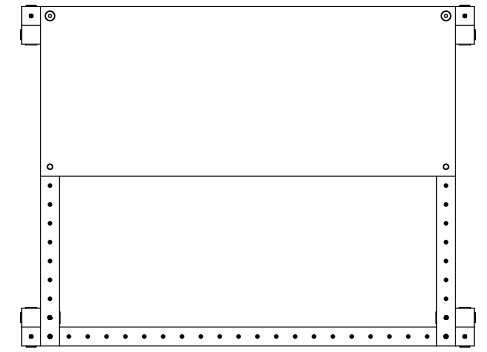

Secure panel to corners of rails by passing the bolt through the panel and rails below.

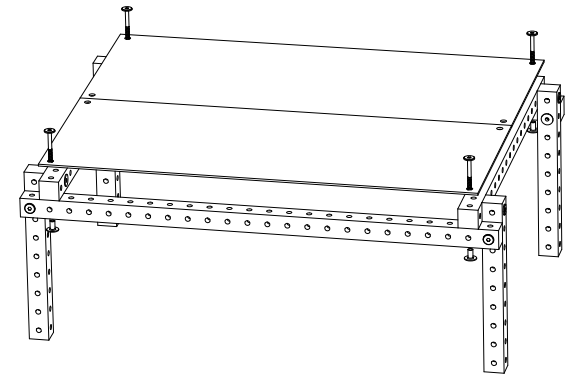

Finally, grab those short bolts and secure the inside corners to the rail below.

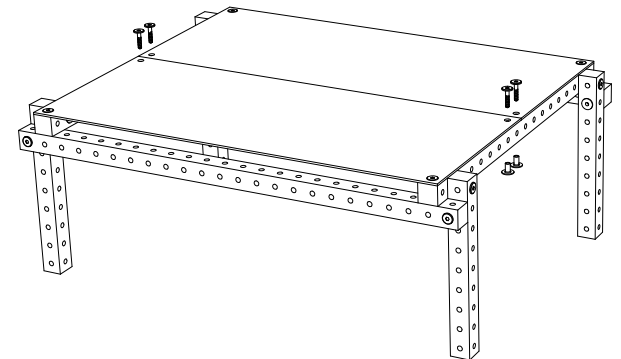

Step 4

Tighten Up

Your table is now complete. Go ahead, tighten down all the bolts and give yourself a high five!