

Laptop Tray Desk Mount

Instruction Manual

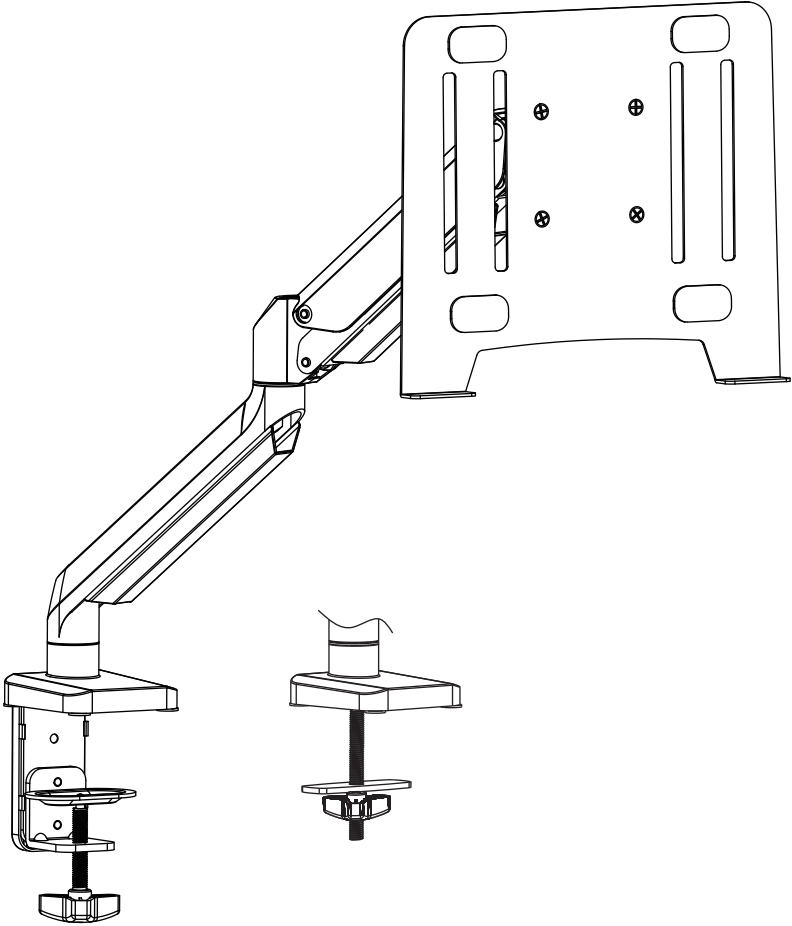

WARNING!

If you have any confusion or are not quite sure about the installation, please do not hesitate to ask for our help.

Before assembly, please check and make sure all necessary accessories are included and undamaged. Improper installation, such as using the product for monitors over its load capacity or for any purpose not explicitly specified, may cause damage or serious injury. We would not be liable for any damage or injury caused by improper mounting or inappropriate use.

The kit contains small items that could be choking hazards if swallowed. Please keep them OUT OF REACH OF CHILDREN UNDER 3 YEARS OLD. ADULT SUPERVISION IS REQUIRED.

PACKAGE CONTENTS

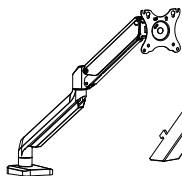

A (x1)
Monitor Stand



A1 (x1)
Cable Cover

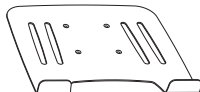

B (x1)
Laptop Tray

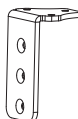

C (x1)
Clamp Base Support

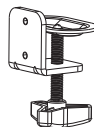

D (x1)
Clamp



E (x1)
Base Support Cover



F (x1)
Long Screw



G (x1)
Base Support



H (x1)
Support Plate



I (x1)
Wingnut



J (x5)
Bolts M6x12



K (x4)
Pad



L (x4)
Screw M5x10



M (x4)
Nut M5



N (x1)
Strap



O (x4)
Pad



P (x1)
4mm Allen Key



Q (x1)
6mm Allen Key

NOTE: Not all hardware included will be used.



DO NOT EXCEED WEIGHT CAPACITY.

ASSEMBLY STEPS

Warm Tips

You could also refer to the Video Guide about installation on our product page.

STEP 1: Choose a mounting option

OPTION A: Clamp Installation

Mount clamp base support (C) to monitor stand (A) with Bolts (J). Bolts could be tightened by the 4mm Allen Key (P), then Apply pads (O) to the monitor stand (A) bottom to avoid desk scratches.

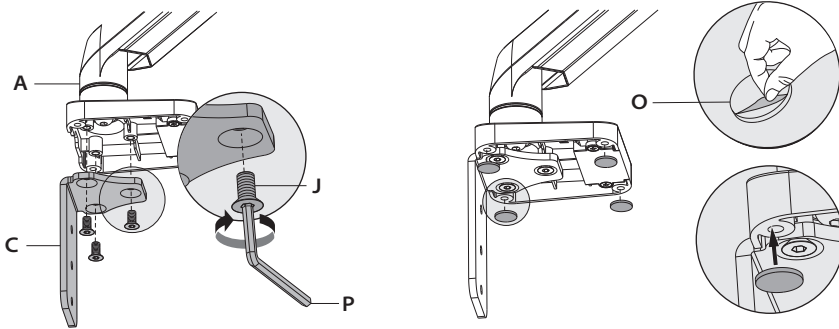

Attach Clamp (D) to clamp base support (C) with Bolts (J) and 4mm Allen Key (P).

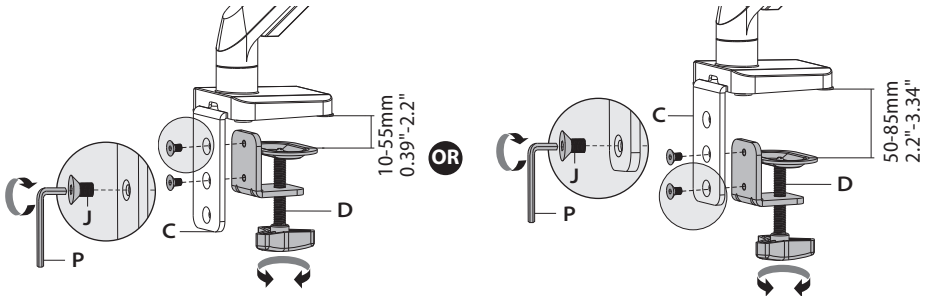

Adjust the Clamp width to fit with desk. Secure stand to desktop by tightening Clamp (D) or by Allen key (Q). Attach base support cover (E) to clamp base support (C).

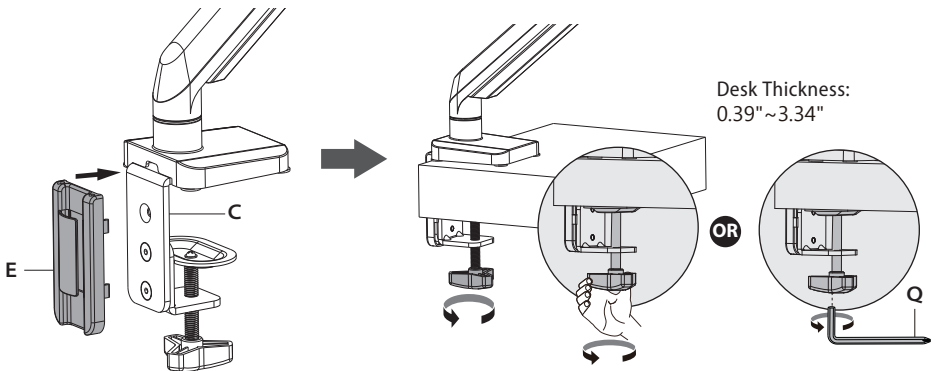

STEP 1: (Continued)

OPTION B: Grommet Base Installation

Place long screw (F) through the center of base support (G).

Mount grommet base to monitor stand (A) Bottom with Bolts (J) and tighten by 4mm Allen key (P).

Apply pads (O) to the monitor stand (A) bottom to avoid desk scratches.

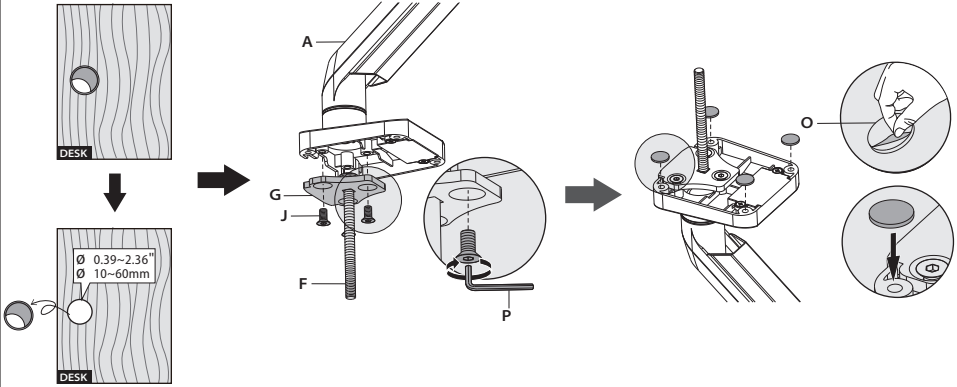

Run long screw (F) through grommet hole on desktop. Attach support plate (H) and wingnut (I).

Secure stand to desktop by tightening the Wingnut (I).

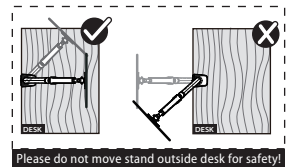
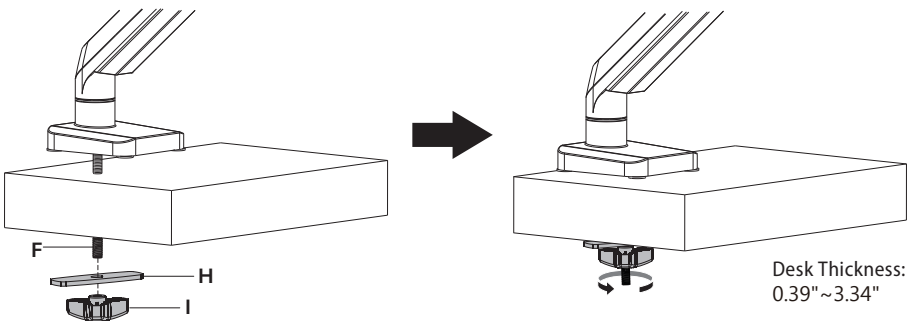

STEP 2: Attach the monitors to the arm

OPTION : Laptop Tray

Install the Monitor Stand (A) to the laptop tray (B) using 4pcs screws (L) and 4pcs nuts (M), tighten by 6mm Allen key (Q). Apply pads (K) to the laptop tray to avoid laptop scratches.

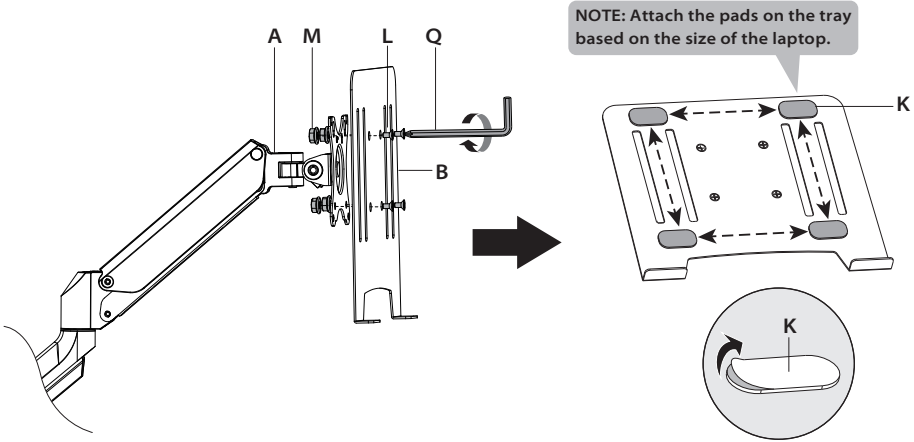

STEP 3: Secure the Laptop on the Laptop tray

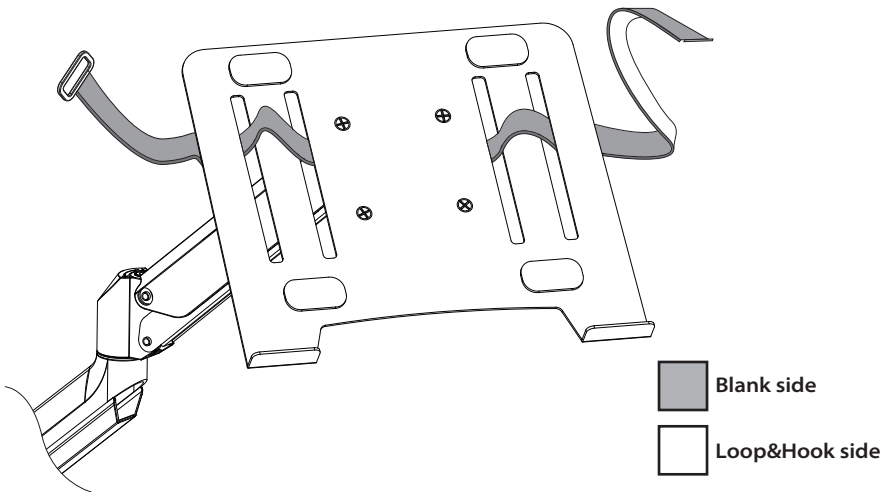

STEP 3: (Continued)

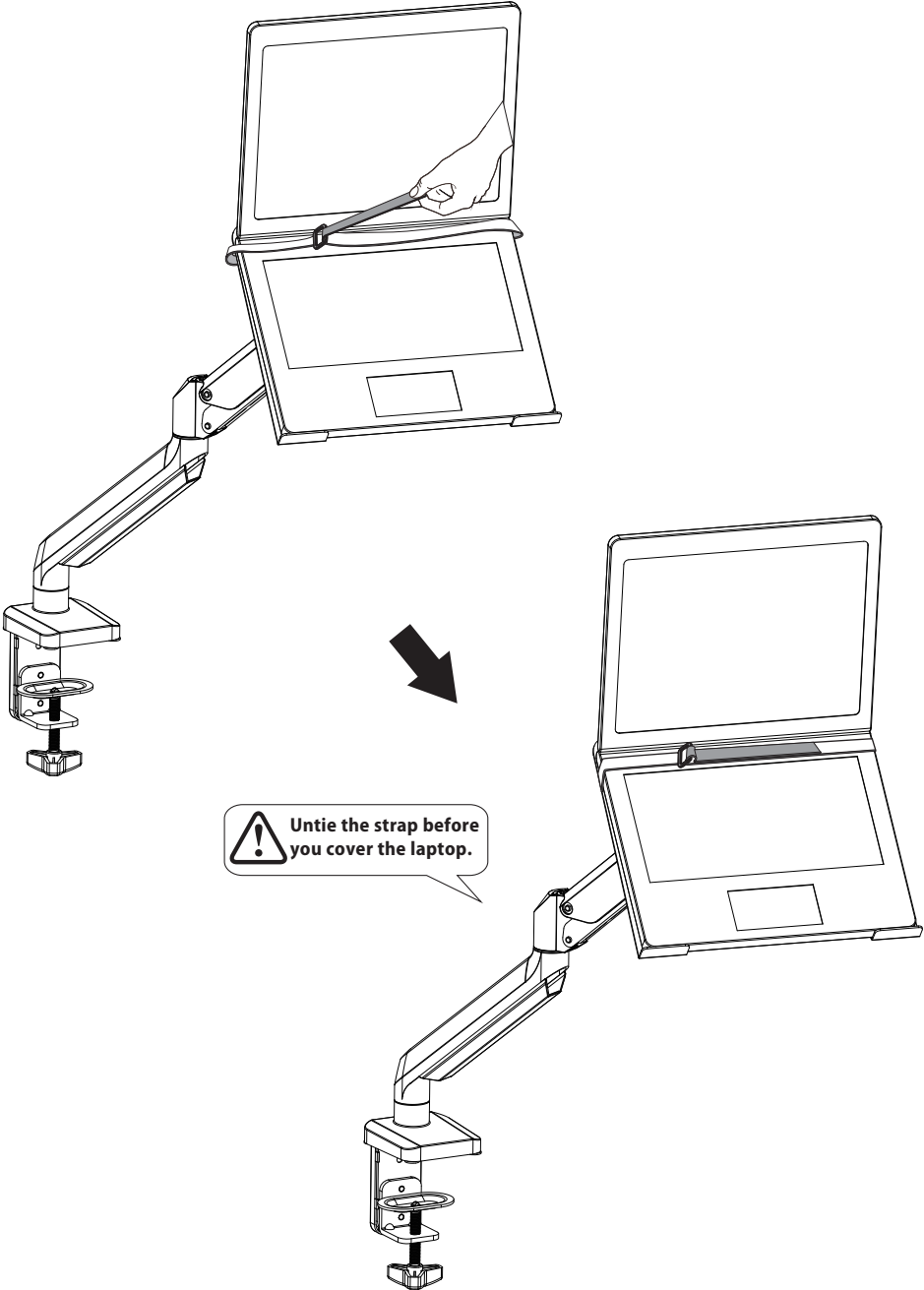

STEP 4: Tilt Adjustment

Problem:

If monitor face down

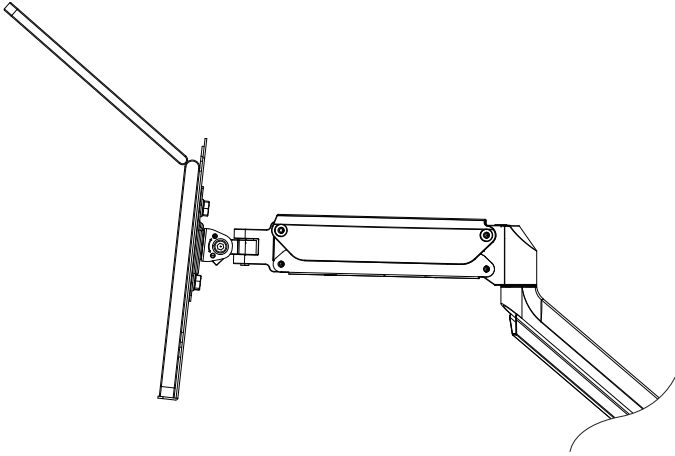

Solution:

1. Loosen the tilting bolt.
2. Hold the bottom of monitor with one hand and adjust to determine your desired tilt angle.
3. Retighten the tilting bolt towards "+" to fix the angle.

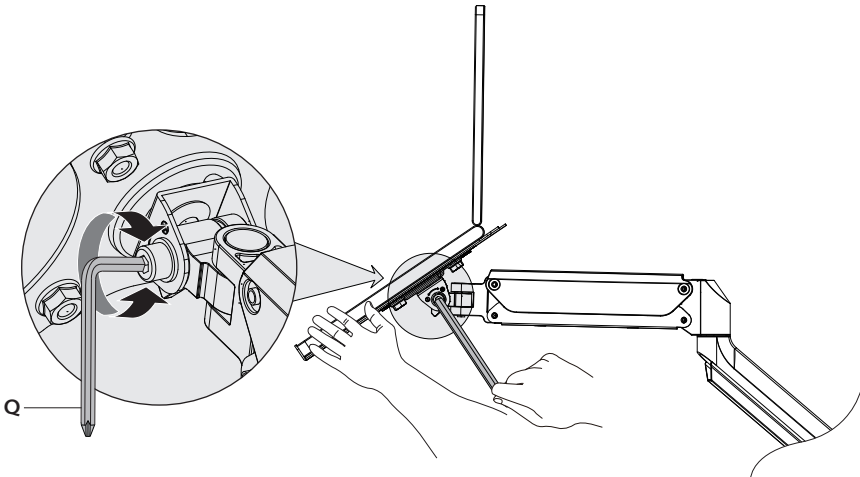

STEP 5: Adjust the tension

For proper functioning of this mount, depending on different weight of monitor you might need to adjust tension in upper arm by using a 6mm Allen key (Q).

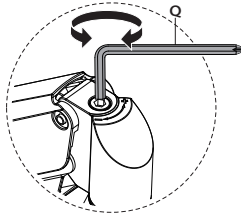
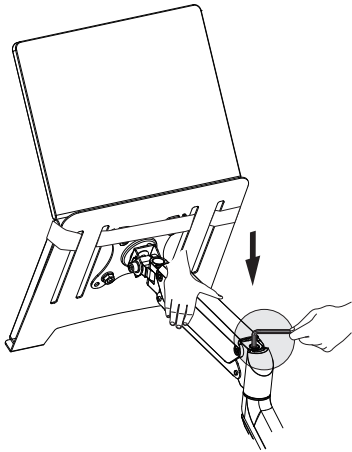

NOTE1:

If the bolt is covered over, please hold the upper arm and press it down to maintain a horizontal position, and then you can see the adjustment screw at the joint. Be sure to keep the arm in a horizontal position during adjustment.



Situation 1: Arm falls down

Upper Arm with monitor falls down and fails to stay where intended.

Solution:

Turn the inside screw counterclockwise(“+”direction) to increase gas spring tension until the arm can stay as intended.

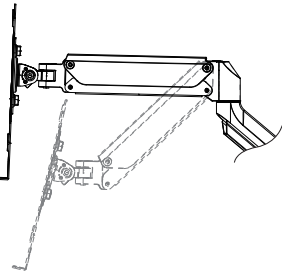

Situation 2: Arm rises up or can't press down

Upper Arm with monitor rises up and fails to stay where intended.

Solution:

Turn the inside screw clockwise(“-”direction) to decrease gas spring tension until the arm can stay as intended.

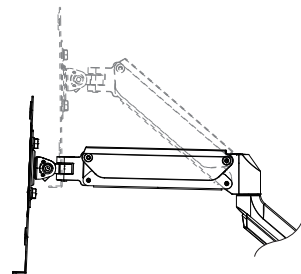

NOTE2:

As for how many circles the screw should be turned, the table below is for reference.

Monitor Weight	3.3lbs (1.5kg)	6.6lbs (3kg)	8.8lbs (4kg)	11lbs (5kg)	13.2lbs (6kg)	15.4lbs (7kg)	17.6lbs (8kg)
Circles(AT LEAST)	min	3	4	6	8	10	12

STEP 6: Cable Management

Remove Cable Cover

For both bottom and upper portion of the arm, just slide the cable cover up and away from the arm, do not need to take much effort to pull the ends of the cable cover away from the arm.

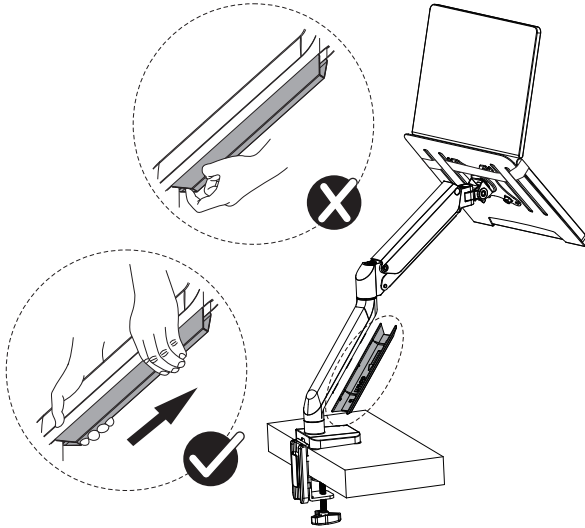

Attach Cable Cover

On the bottom portion of the arm, insert the cable and slide the cable cover down; On the upper portion of the arm, insert the cable and press the tabs on the inside of the cable cover slightly inward and slide down to reattach the cable cover.

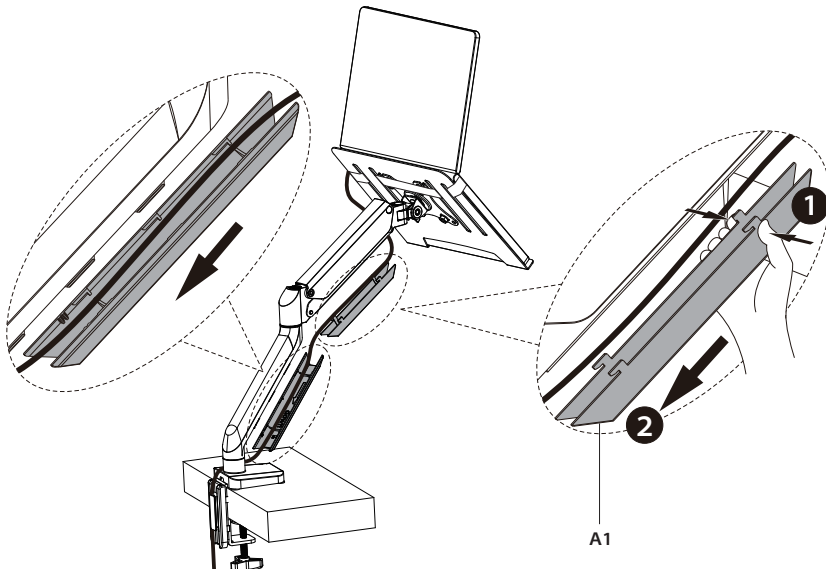

Adjust as Desired

Allen key (P,Q) can be stored in Base Support Cover(E) for next time using.

Note:

When tilted, if the monitor sags or does not stay, please fasten the tilting bolt on the mount until the monitor can be held at any angle as needed.

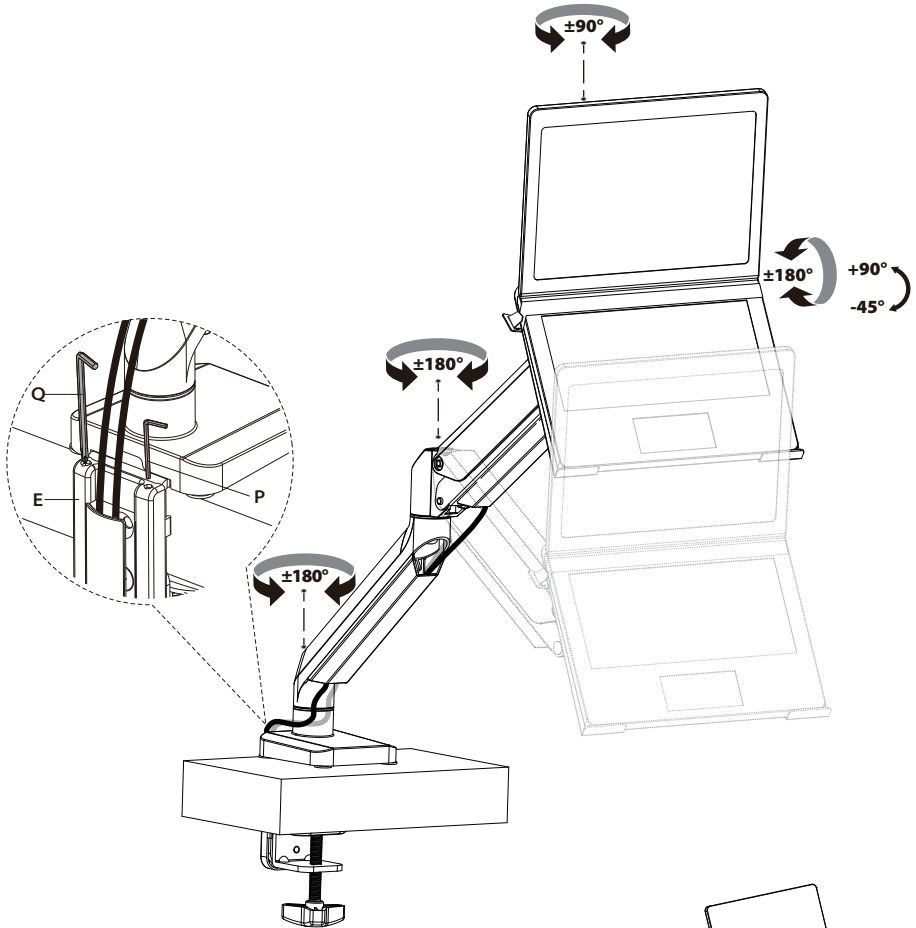

Note: To ensure stability, the tightness of the rotating axis has been preset, so it would be kind of difficult to rotate the VESA plate.

Suggestion: Please attach the monitor first, then hold the two sides of it with both hands, and rotate vigorously.

If that doesn't work out, please do not hesitate to ask for our help.

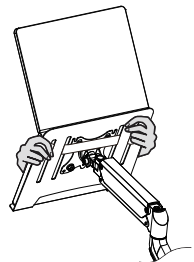

Product Dimensions

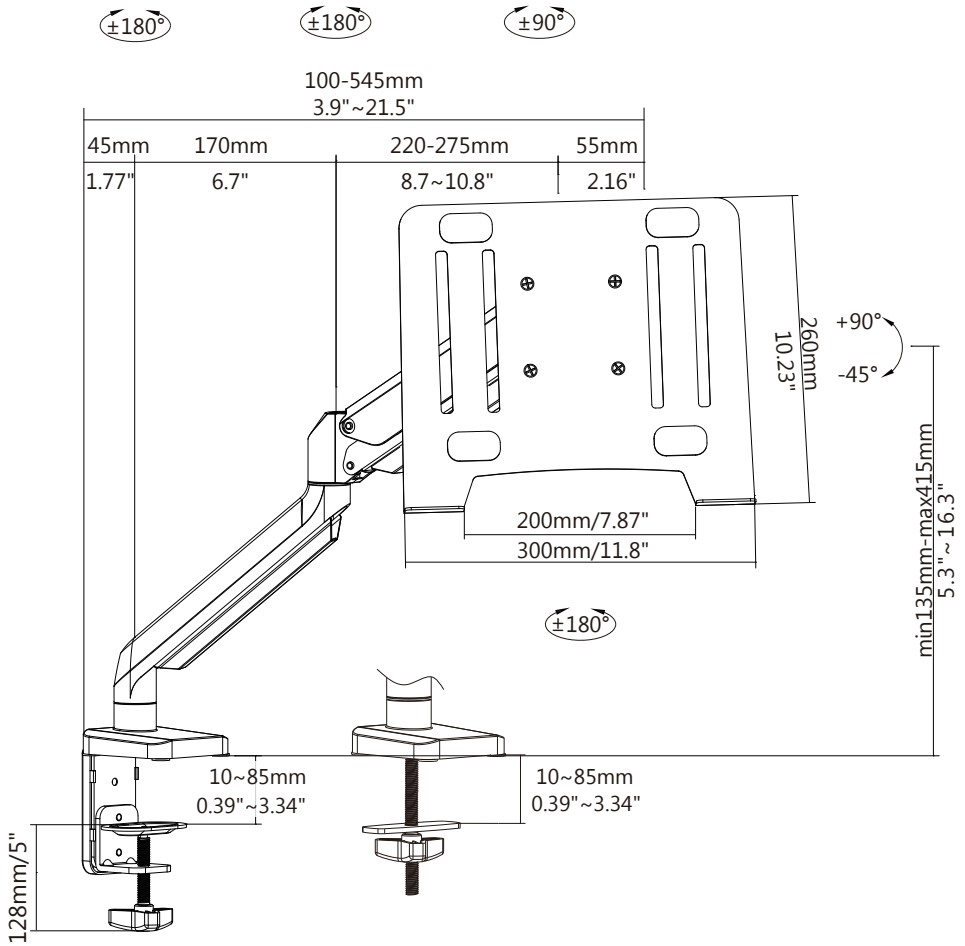

**CAUTION AND MAINTENANCE:**

- Never allow children to climb, stand, hang, or play on any part of monitor or stand.
- This product is intended for indoor use only. Using this product outdoors could lead to product failure and personal injury.
- Check that the bracket is secure and safe to use at regular intervals (at least every three months).