

Ethos 400 Stove

- Log Effect

- Live Fuel Effect Radiant Convector Stove



Installation and Users Instructions

These instructions should be read by the installer before installation and then should be handed to the end user when the installation is complete.

This is an official requirement and is the responsibility of the fitter of this appliance.

Having installed the appliance, the installer should take the necessary steps to ensure that the user fully understands how to operate the appliance and is also made aware of the fire's basic cleaning and maintenance requirements.



SECTION	PAGE
Notes for the Installer and End User	3
Installation Requirements	5
Installation Procedure	6
Installation - Class One Flue	7
Commissioning	8
Technical Data	10
Replacement Parts	10
Trouble Shooting (GAS SAFE Engineer Only)	10
Users Instructions	13
Cleaning and Maintenance	19
Log Layout Instructions	20
Trouble Shooting (User)	24
Guarantee	24

NOTES FOR THE INSTALLER AND END USER



This appliance has been designed, tested and manufactured to EN613 and **must** be installed by a qualified Gas Safe Registered Installer in accordance with the Gas Safety (Installation and use) regulations 1994 and all other relevant standards. This appliance is intended for use on a gas installation with a governed meter.

This appliance can be installed as a freestanding outset stove or into an inglenook type opening served by a Class I (7" or 175mm diameter) or a Class II (5" or 125mm diameter) chimney / flue of at least three metres in height.

Before installation, ensure that the local conditions, (identification of gas type and pressure) and the adjustment of the appliance are compatible. Never place combustible material directly in front of this appliance. Floor covering such as carpet, wood or laminate is suitable to use due to the low operating temperature of the stove.

Dimensions

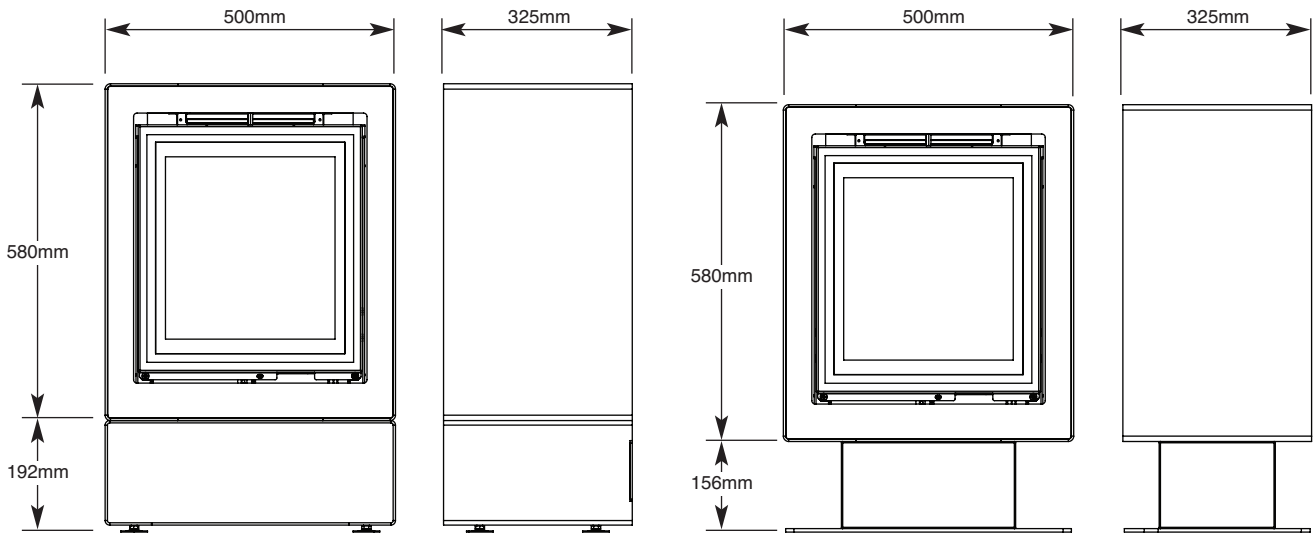

Minimum Inglenook Builder's Opening:
Height - 997mm (Log store) 961mm - (Plinth)
Width - 776mm
Depth - as required but 70mm at rear

Fig. 1

Minimum Clearances

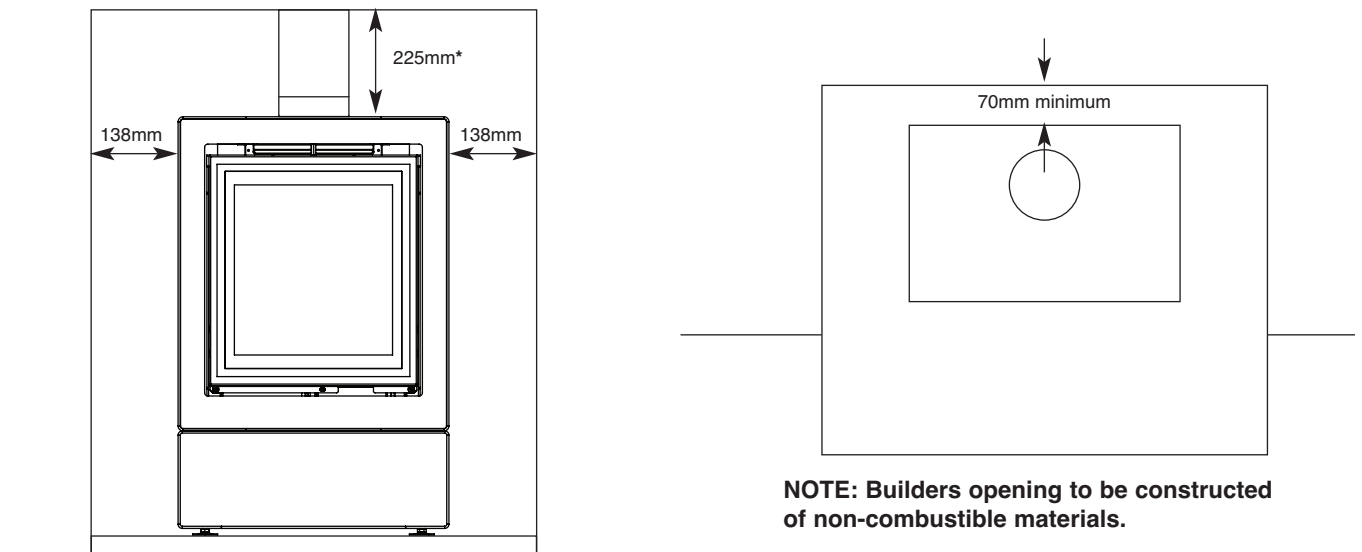

Fig. 1a

NOTE: Builders opening to be constructed of non-combustible materials.

* If using a wooden lintel, a minimum clearance of 225mm is required from the top of the stove to the underside of the lintel.



This fire is a very effective heating appliance and must be fitted against a wall of non-combustible material as classified in BS 476-4:1970 (2007).

All parts of the appliance become hot while running and should therefore be considered to be working surfaces.

An air vent is not required for this application. The appliances have been tested without the need for additional air requirements.

We recommend that if the chimney/flue has been used for solid fuel, it is swept prior to installation of this appliance and that any flue restrictor or damper plate should be removed.

The chimney/flue must always generate a positive up draught to ensure safe operation.

The installer must then establish that all the products of combustion are entering the flue within ten minutes of lighting from cold. This can be verified by inserting a lit smoke match into the central duct immediately above the door. It should NOT be inserted into the left and right convector ducts.

This operation should be carried out before fitting the trim so no staining occurs (see 'Spillage Test' page 5).

An isolation valve must be fitted adjacent to the appliance. When closed, this will allow the complete burner and control assembly to be disconnected for maintenance or repair in accordance with national regulations.

The gas supply should be provided by a semi rigid pipe with an 8mm diameter and should be no longer than 1.5 metres in length.

NOTE: When the gas supply pipe is passed through masonry or other brickwork always ensure that the end of the pipe is covered to avoid any debris passing through into the appliance controls.

The appliance is fitted with an Oxygen Depletion Sensor (ODS) that monitors the room for products of combustion. If products are detected, the ODS will automatically shut down the appliance. If this situation arises, re-light the appliance, referring to the user instructions (page 13).

If shut down re-occurs, a qualified person must be called to thoroughly check the appliance. The spillage monitoring system (ODS pilot) must not be put out of operation or be tampered with or adjusted by either the installer or the user. If the unit is found to be at fault it should be replaced with the manufacturers original replacement parts.



This appliance must only be installed in Great Britain or Ireland.

1. This fire is a natural gas appliance and has been designed for use with the following applications:

a) Class I - Conventional brick or stone chimney as used for a solid fuel fire with a cross sectional dimension of 225mm x 225mm (9" x 9"). This chimney should be lined with a 125mm (5") minimum dia flexible stainless steel liner from the appliance up to the terminal. Ref BS5871-2: 2005.

NOTE: The debris deflector panel (part No. LEG-DDP01) can be installed into an inglenook type fireplace if a flue liner is not a viable option. Ref BS5871-2: 2005.

Any permanent flue restrictions or variable dampers are to be removed or locked in the fully open position. The chimney should also be swept prior to installation.

b) Class II - An insulated flue (twin wall) having a minimum diameter of 125mm (5") and a minimum effective overall height of 3 metres (10').

NOTE: If the fire is to be used with an existing brick or stone chimney, a 125mm (5") minimum diameter flue liner conforming to BS715 may be used.

2. Care should be taken to prevent any damage being caused to surrounding soft furnishings or decoration, e.g. many embossed vinyl wall coverings may become discoloured if placed too close to the appliance.

3. A suitable proprietary fire surround with 100°C rating may be used with a minimum clearance from stove top to underside of shelf of 225mm, providing that the depth of shelf is 150mm or less. It is recommended that combustible materials are not placed directly above or adjacent to this appliance.

FLUE FLOW TEST

A flue flow test (smoke test) is carried out to check the effectiveness of the flue and to ensure that there is no leakage into another part of the premises (including any loft), or as appropriate other adjoining premises (this is particularly important where a number of chimneys combine into a multiple stack).

The flue flow test should be carried out using a suitable smoke pellet which the pellet manufacturer claims to generate 5m³ of smoke in 30 seconds burn time.

These gas fires should have the flue flow test carried out with the appliance in position but not connected to the gas supply so that the smoke test can be carried out with representative flue flow conditions.

A warm flue will be more effective than a cold flue. If the flue is reluctant to draw, which can be initially assessed by lighting a smoke match at the intended position of the appliance flue connection, introduce some heat into the flue for a minimum of 10 minutes using a blow torch or other means.

Other factors, such as weather conditions and a combination of materials used to construct the flue can all influence the flue draught. The pre-heating process may require as much as half an hour before the flue behaves satisfactory as a blow torch does not represent the volume of heat consistent with the normal appliance operation.

A Flue Flow Test should be checked as follows:

1. Carry out those visual checks as indicated previously, and continue only if satisfactory.
2. Establish that an adequate air supply is available for the combustion of the appliance
3. Close all doors and windows in the room that the appliance is to be installed.
4. Light a smoke pellet at the intended position for the appliance. Place the inset fire case into position.
5. The test is satisfactory if:
 - there is no significant escape of smoke from the appliance position.
 - there is no seepage of smoke over the length of the flue.
 - smoke is discharged only from the correct terminal.

VENTILATION

No special ventilation bricks or vents are required in the room containing the appliance, providing that normal adventitious room ventilation exists. The installer must determine this by carrying out a spillage test.

SPILLAGE TEST

To check for satisfactory clearance of products of combustion, close all doors and windows and leave the fire burning on high setting for a minimum of ten minutes. The left and right hand ducts are for convection only. The central duct above the glass door has a visible hexagonal post in the middle, this post indicates the approximate depth to place a lit smoke match. All the smoke must be drawn into the flue. If spillage occurs, allow a further ten minutes and repeat the test. Should spillage still occur turn the appliance off and seek expert advice. To continue the test: If an extractor fan is situated in the room the test should be repeated with the fan running. If there is a connecting room with an extractor fan the test should be repeated with all the doors to that room open and the extractor fan running.

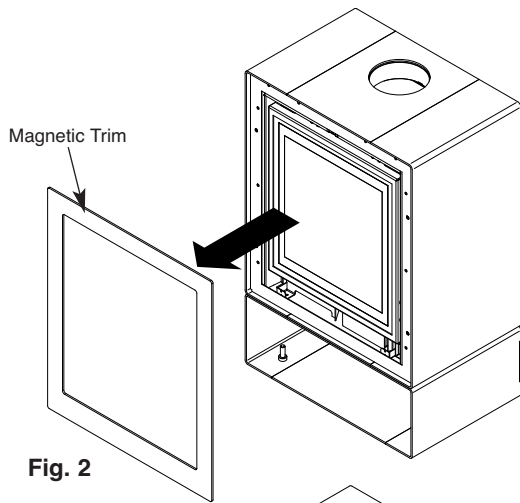

1. Remove the magnetic trim from the front of the stove (Fig. 2).

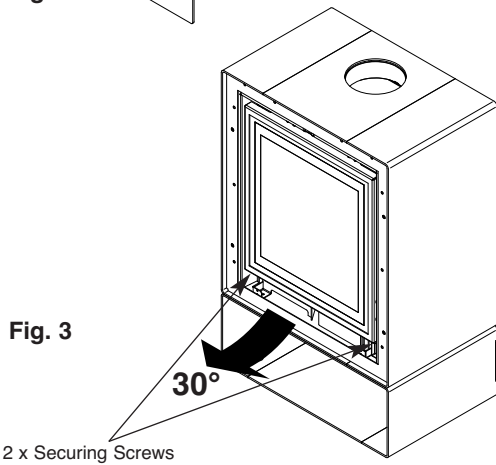

2. Remove the two screws at the bottom of the glass door panel (Fig. 3).

3. Hinge the door upwards by approximately 30° (Fig. 3).

4. Slide the door to the right by 10mm and remove the door from its hinges (Fig. 4).

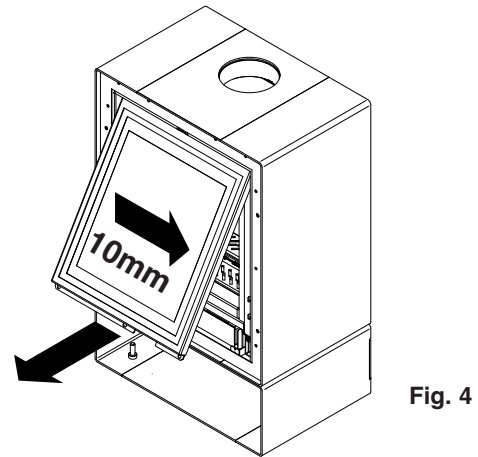

5. Withdraw the black internal top panel (Fig. 5).

6. Lift off the black burner grille. Note - pilot tab to be at the front on re-assembly (Fig. 6).

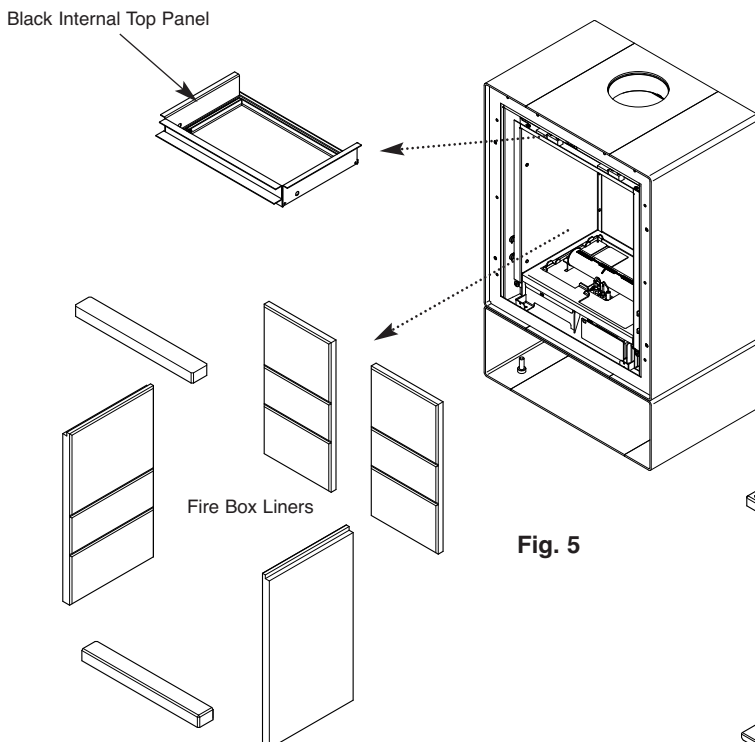

7. Carefully remove fire box liners to avoid damage during installation process (Fig. 5).

8. Remove the lower controls heat shield and gas connection cover panel (Fig. 6).

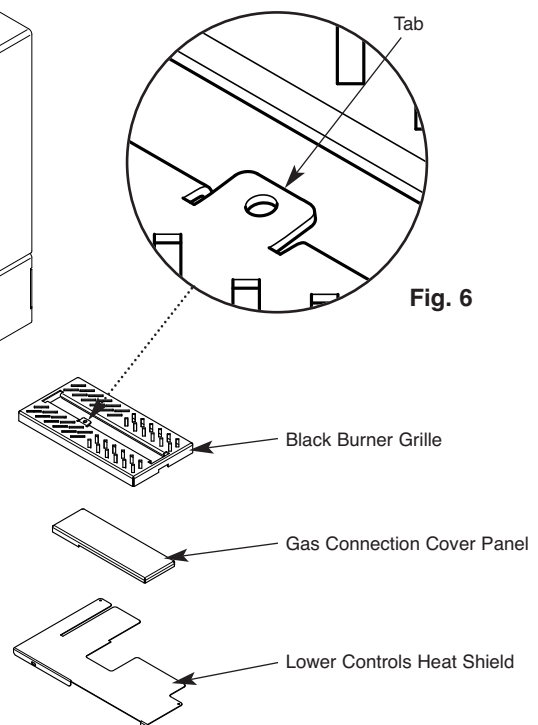

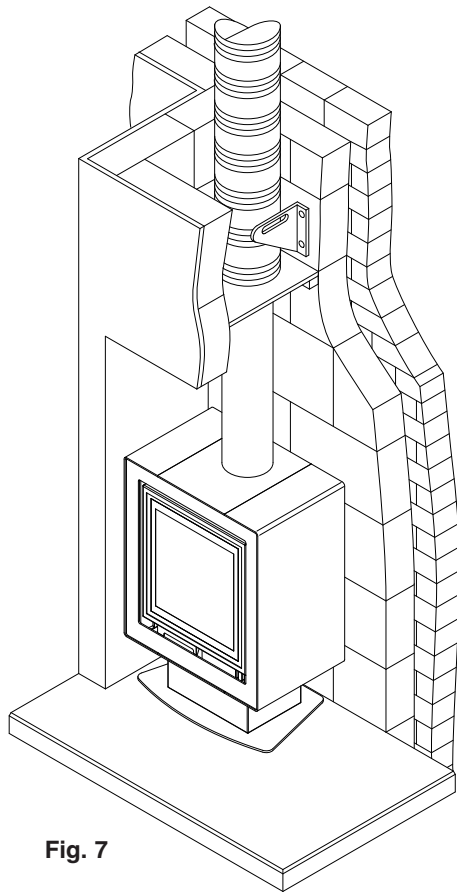

Fig. 7

This appliance should be installed in accordance with BS5871-2: 2005. A debris collection space is not required for a lined chimney. This liner has to be fitted to the top of the appliance via the stove pipe and extend all the way to the top of the chimney capping and terminated by a BS Gas Flue Terminal. If the debris deflector panel LEG-DDP01 is to be used, a catchment space has to be provided having a volume of not less than 12 litres and a depth of at least 150mm below the point where flue gases discharge into the chimney flue.

If the Debris Deflector Panel LEG-DDP01 is to be used, this must be installed into Class 1 brick constructed chimneys only and having a cross sectional area of not less than 52,258mm sq (9"x9").

The deflector panel should be fixed to a register plate of a minimum size of 776mm wide x 440mm deep. The height from the register plate up to the intersection with the flue should be not less than 150mm.

The cut-out size in register plate to accommodate the Debris Deflector Panel should be 360mm long x 215mm wide. The installer shall confirm that the chimney has been swept and is in good condition and has passed a flue performance test before the appliance can be installed with the flue kit.

The following warning attached to the deflector panel should also be observed:

WARNING: This appliance is installed to an unlined chimney. For examination of the debris void and condition of the chimney, refer to the appliance manufacturer's instructions or remove the whole firebox.

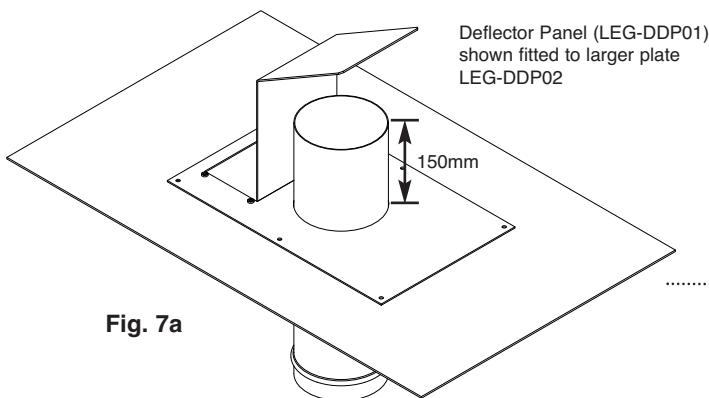

Fig. 7a

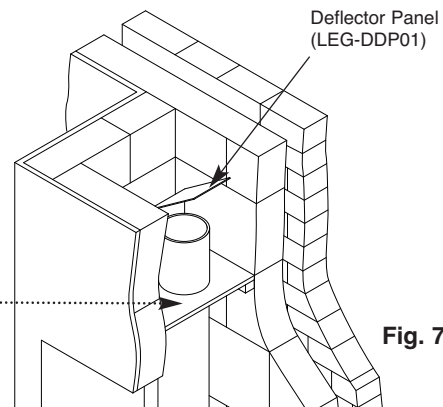

Fig. 7b

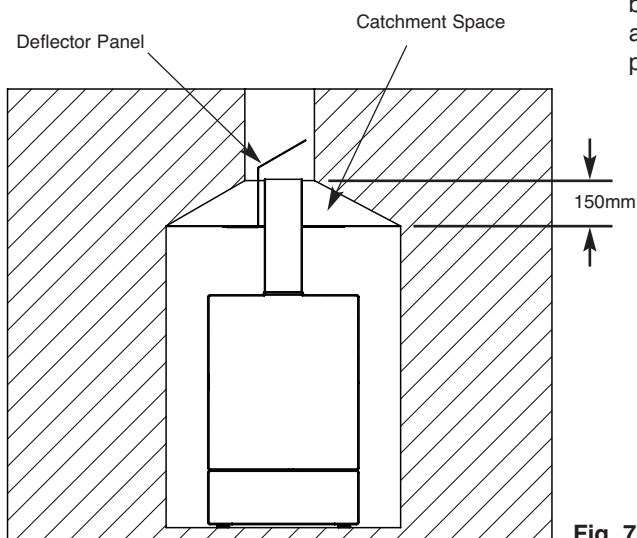

Fig. 7c

The second warning plate should be attached to the burner plate within the appliance, in the position shown adjacent to the data label and with the wing nut provided. See Fig. 7d.

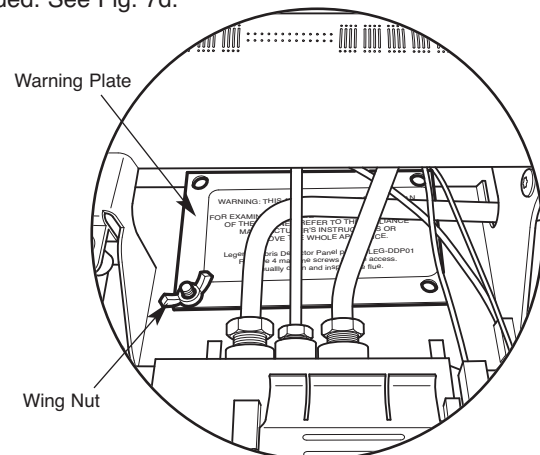

Fig. 7d

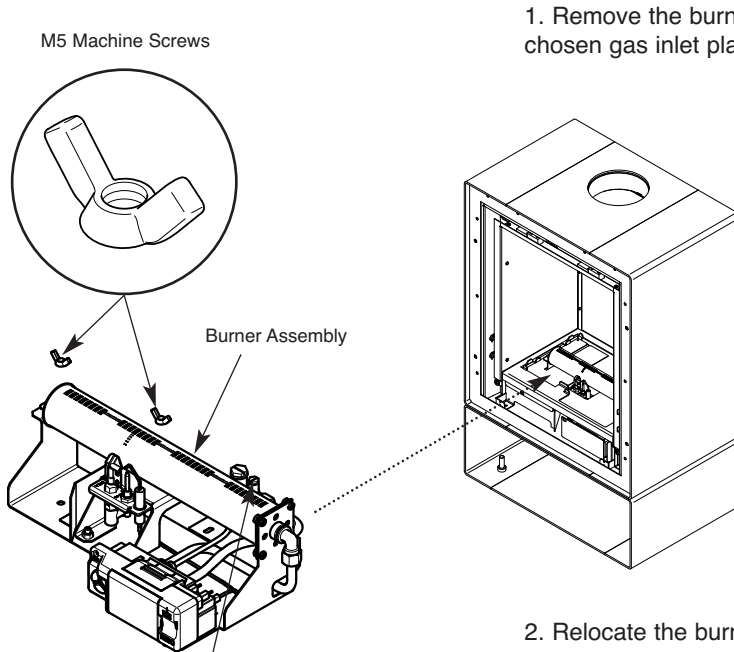

Fig. 8

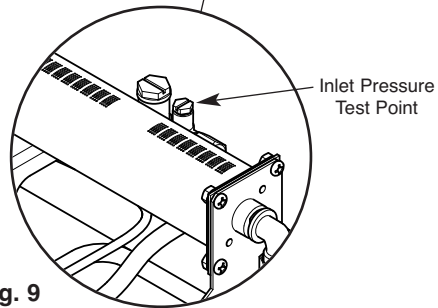

Fig. 9

1. Remove the burner assembly (2 x wing nuts) and chosen gas inlet plate (Fig. 8).

2. Relocate the burner assembly and mark/cut gas pipe to length, then secure burner assembly with the 2 x M5 machine screws and refit the gas inlet cover plate (Fig. 8).

3. Connect manometer to pressure test point on the brass pressure test elbow (Fig. 9) and ignite the burner to check working pressure and gas rate see (page 10). Note: the gas rate is factory set and is not adjustable without specialised Legend equipment.

4. Refit heat shield and ensure gas connection cover panel is fitted (Fig. 10).

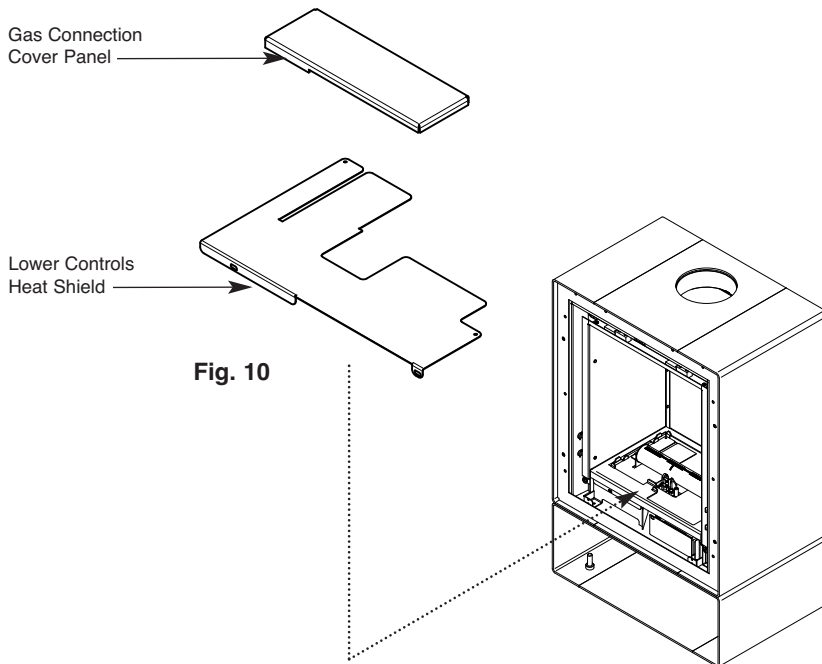

Fig. 10

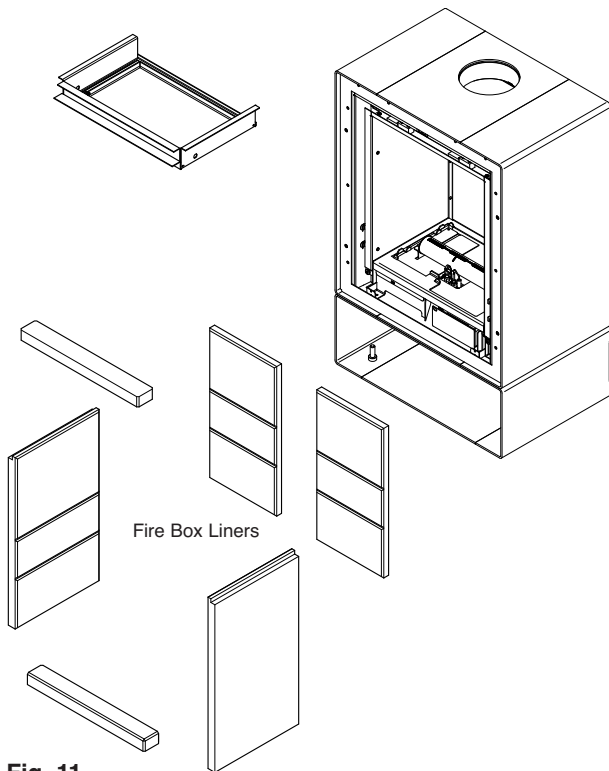

Fig. 11

5. Refit all the back and side liner components and slide black top panel back into position (Fig. 11).

6. At this stage locate the burner top grille on the tabs provided before slotting the remaining liner blocks into position.

Note: The pilot tab should be positioned at the front (Fig. 12).

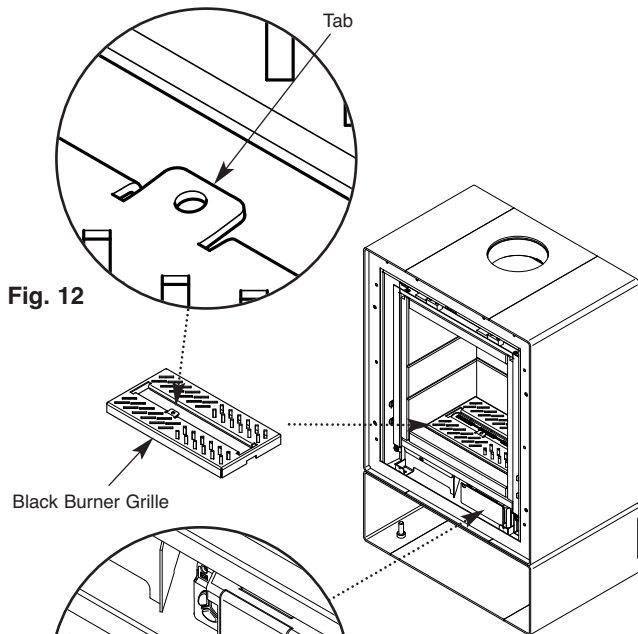

Fig. 12

7. Follow ceramic layout guide (pages 20-22) fitting rear log and bark chippings around the black grille and not on top of the burner skin.

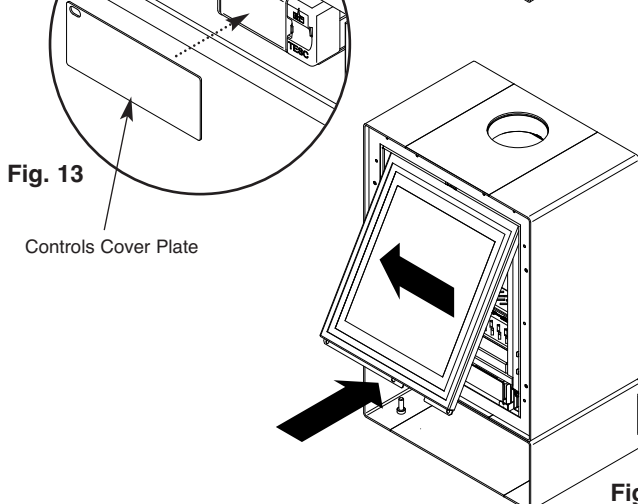

Fig. 13

8. Fit the controls cover plate over the Fire Control ensuring that the indicator light can be seen through the hole in the plate (Fig. 13).

9. Replace the glass door and secure with two 6mm machine screws (Fig. 14).

10. Switch on the appliance and carry out smoke testing as laid out on page 5.

Fig. 14



Model	Ethos 400 Stove	
Gas Type	Natural Gas	
Gas Category	I _{2H}	
Gas Type	G20	
Inlet Pressure (mbar)	20	
Countries of Destination	See table below	
Gas Valve	TESC-01 RF868-30	
Injector Size	Bray 82/360	
Oxypilot	ERTA PG-82-650	
Gas Rate	Full	Reduced
Nominal Heat Input (Gross, kW)	5.5	1.9
Nominal Gas Flow Rate (m ³ /h)	0.524	0.181
Efficiency (net)	80.9	
Efficiency Class	1	
NOx Class	3	
Weight (Kg)	43.8	
Countries of Destination	AT, BG, CH, CZ, DK, EE, ES, FI, GB, GR, HR, IE, IT, LT, LV, NO, PT, RO, SE, SI, SK, TR	

REPLACEMENT PARTS

- Log Set** - The ceramic logs supplied with this appliance can be replaced at service intervals depending on their condition. If the logs do require replacement, the consumer can do so provided that the Ceramic Component Layout Instructions (pages 20-22) are adhered to. Under no circumstances should additional/extra logs be added. Only genuine Legend replacement parts should be used. **Order Ref: ETHLOG01**
- Oxygen Depletion Sensing Pilot** - In the unlikely event of a pilot failure, the pilot assembly should only be replaced by a **Gas Safe Registered Engineer**. The user must not carry out this work. **Order Ref: ETH01**
- TESC Valve** - In the unlikely event of control valve failure, the assembly should only be replaced by a **Gas Safe Registered Engineer**. The user must not carry out this work. **Order Ref: ETH02**
- Glass Panel** - Should the glass become cracked or broken, the fire should not be used under any circumstance. **Order Ref: ETHGLAS01-02**
- Glass Rope Seal** - The integrity of the glass rope seal should be checked on service and replaced if necessary by a **Gas Safe Registered Engineer**. **Order Ref: ETHSEA01-02**
- Remote Control Display Handset** - **Order Ref: ETH04**

TROUBLE SHOOTING (GAS SAFE ENGINEER ONLY)

NOTE: The purpose of the Error code is to give some information as to the potential reason for the fire not starting rather than just no flame. The appearance of an error code does not mean there is necessary a fault with the control or the appliance, it could be external factors outside the control that could cause error codes to appear from time to time and they could just be a one off event , so please check and work through the suggested service actions below before considering changing the control box. These codes are there to help with a more certain and efficient servicing of the appliance. Changing the box without working through the guide could lead to an unnecessary and expensive service and probably a repeat visit to fix the real fault.

SERVICING MUST ONLY BE CARRIED OUT BY COMPETENT PERSONAL WHO HAVE CURRENT QUALIFICATIONS AND ACCREDITATION (I.E. GAS SAFE)

NOTE: After correcting fault, perform a restart to reset error display to normal standby mode. Also depending upon the repair, air will need to be bled out of the system and it may take several start attempts to do so. E00 may appear and need to be reset a few times during the purging process, depending upon the length of supply pipe. Bleeding the supply pipe via the isolation valve pressure test point will help speed up this process.

NOTE: Before undertaking any actions on the servicing as detailed below , replace the batteries in the control and handset (if applicable) with new and know to be good batteries. Faulty batteries will cause error codes. There is a difference between old and faulty batteries and they may give false errors if the batteries are faulty. **ALWAYS CHANGE ALL THE BATTERIES TOGETHER AND NOT JUST ONE OR TWO AND ALWAYS OF THE SAME MAKE AND TYPE (I.E MANUFACTURER AND MODEL TYPE).**

Generally : After replacing the batteries, to clear the error code perform a start cycle by pressing the start button as normal. Then press again in the same way to attempt a new start cycle. The error code must be cleared this way after every error code is displayed to start again.



Error Code E01

Meaning: This error is intended to indicate that possibly the content of CO is too high in ambient atmosphere. This error will usually be generated when there has been a good electronic flame signal, but the temperature of the couple was once hot enough but then become cooler.

Possible reasons:

- Problems with chimney or room air inlets (insufficient air circulation).
- Unstable pilot flame (i.e. wind, insufficient thermocouple couple position).
- Contaminated pilot, giving poor flame that heat thermocouple).
- Poor position of Ceramic parts (i.e. coals logs or matrix).
- Intermittent failure in Thermocouple (only when hot) Inner wire in head maybe making contact when cold but not when hot).

Error Code E02

Meaning: Ambient around Gas valve in the fire too hot (exceeded 72°C).

Note: This error protects the fireplace and the valve from excessive temperatures.

Possible reasons:

- Faulty installation of fire (not sealed in correctly in fire opening).
 - Problems with chimney (insufficient air circulation).
 - Poor position of Ceramic parts (i.e. coals logs or matrix).
- Note: Batteries do not tolerate well high ambient temperatures, eventually this could cause them to leak and damaging the valve and new valve will be required and is not covered by any warranty. Typically the maximum temperature for alkaline batteries is 50°C.

Error Code E03

Meaning: Thermocouple connection to valve issue. Incorrect reading from thermocouple.

Possible reasons:

- No Thermocouple connected.
- Thermocouple connection reversed / connected incorrectly (see fig xx for correct connection).
- Insulated thermocouple wire shorting to chassis earth (damaged insulation).
- Damaged or defective, worn out thermocouple.

Error Code E04

Meaning: Flame detected on pilot after valve has shutdown.

Possible reasons:

- Carbon or soapy / conductive contamination on spark electrode.
- Combustable material burning on pilot near electrode (Carbon deposits etc).
- If Easytest box used :- simulate flame switch not operated correctly.

Error Code E05

Meaning: Flame detected on pilot before valve has started.

Possible reasons:

- Carbon or soapy / conductive contamination on spark electrode.
- Combustable material burning on pilot near electrode (Carbon deposits etc).
- If Easytest box used :- simulate flame switch not operated correctly.

Error Code E06 & E07

Meaning: Occurs when supply voltage is too low to operate the valve.

Possible reasons:

- Batteries are completely flat (may display random error codes in this case not just E06 and 7).
- Damaged battery contacts (dirty, corroded, bent so not making strong contact with batteries).
- Short circuit in external wiring or connected accessories (i.e. wired control panel, cable shorting to chassis earth).
- Defective power plug power supply (if used) or damaged wiring to it.
- Contact problem of slide switch (moving on/off..on/off several time may clean contacts).
- Batteries not in correct way around.

Error Code E08, 09, 10 & 51

Meaning: Arises when a device connected to the TESC extension socket does not work correctly.

Possible reasons:

- If nothing connected: are the links missing, in wrong position or a bad contact.
- Failure in extension module connected to extension connector.

Error Code E11,12,13,18, 25, 28, 29, 30, 31, 33, 36, 44, 45, 63

Meaning: Not applicable - only should occur during valve manufacturing and reserved for future use.

**Error Code E14, 15, 16, 17**

Meaning: Occurs when buttons on valve (or wired control panel) do not work or are not wired correctly.

Possible reason:

- Buttons are sticking or blocked.
- Buttons are damaged.
- Cable damaged or short circuit to ground (wired control panel).

Note: disconnect wired panel (if applicable) and test again to determine the root cause.

Error Code E19, 20, 27, 50, 54, 57, 58, 59, 60, 61

Meaning: Occurs when internal CPU diagnostics runs self tests and returns invalid results.

Possible reason:

- EMC problems (in this case, twist ignition cable around thermocouple wire several times to quench radiated EMC emissions).
- Spark track out somewhere but not at electrode creating unusual interference.

Error Code E21,22

Reserved for later use.

Error Code E23

Meaning: Valve performed 40 000 start operations.

- End of life – raises when valve proceed more than 40.000 burner starts (40000 is over 15 years life based on 7 starts a day every day for 15 years).

Error Code E24

Meaning: Occurs when thermocouple does not reach its final temperature within 1 minute.

Possible reasons:

- Aged thermocouple.
- Thermocouple wire insulation damage and shorting to metal chassis.
- Problems with chimney or room air inlets (insufficient air circulation).
- Unstable pilot flame (i.e. wind, insufficient thermocouple position).
- Contaminated pilot, giving poor flame that heat thermocouple(see section on pilot).
- Poor position of Ceramic parts (i.e. coals logs or matrix).

Error Code E26

Meaning: Occurs when a power supply with wrong pinning is connected to the USB-socket.

Error Code E32, 43, 46, 47, 52, 53, 55, 56, 62

Meaning: Occurs when a self test procedure of the valve electronic fails.

Possible reasons:

- Completely flat batteries.
- Liquids inside electronic (i.e. after leakage test with soapy water).

Error Code E33, 34, 35, 37, 38, 39, 40, 41, 42

Meaning: Occurs when internal piston is having trouble moving.

Possible reasons:

- Contamination of valve in- outlets with debris from supply pipe or other.
- Mechanical damage of the valve.

Note: After cleaning etc, before resetting these error codes allow the fire to cool down. Upon starting the valve will reinitialise and perform a self recalibration and needs to be cold when doing this recalibration.

Note: If the valve needs replacing, check the pipework for contamination to avoid repeated problems.

Error Code E48

Meaning: Occurs when the control detects a short circuit of the couple.

Possible reasons:

Thermocouple connection reversed / connected incorrectly. Insulated thermocouple wire shorting to chassis earth (damaged insulation).

Damaged or defective , worn out thermocouple.

Weak connection of thermocouple to valve.

Error Code E49

Meaning: Occurs when the control senses a false flame signal on electrode.

Possible reasons:

- Contamination of the electrode with carbon deposits, conductive liquids(leak detection spray) or similar.
- Contamination of the rear of the valve where the thermocouple and ignition cable connect to the valve with conductive liquids(leak detection spray) or similar.

Note: It is critical to avoid leak detection fluid to contact any part of the valve other than the threads where the pipe connects. Leak detection fluids are highly corrosive and will damage any electronics they come into contact with. Other forms of leak detection should be used.



Warnings

All parts of the appliance become hot while running and should therefore be considered to be working surfaces.

A suitable guard may be required to take account of special hazards that exist in nurseries and other places where there are young children, aged or infirm persons.

Curtains are not to be placed directly above the appliance.

It is recommended that combustible materials are not placed directly above this appliance.

This appliance should not be used if the glass door has been removed, broken or is open.

Fire Control

This control is situated on your fire. The drawing shows the main features of the control.

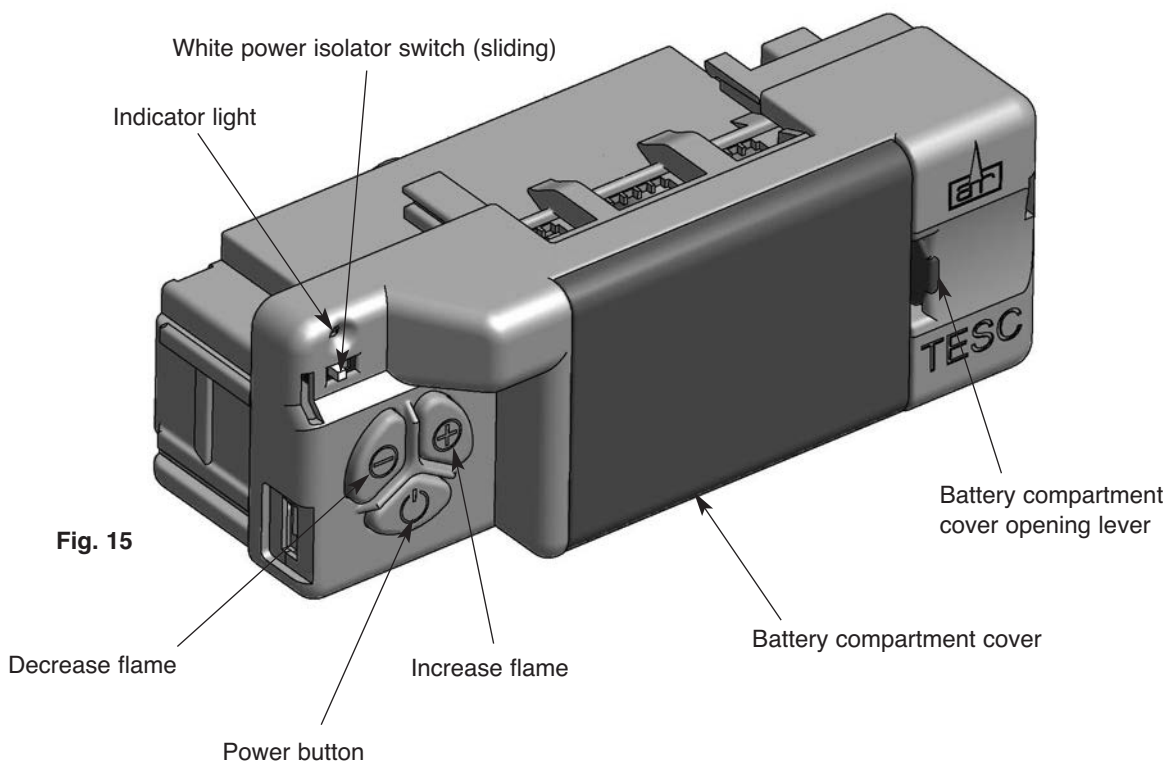

Check the power isolator switch is in the On position (I).

To start the fire, press the power button and hold for 1 second then release. The burner will light within around 1 to 10 seconds, adjust to the maximum power setting.

The power of the burner can be adjusted up and down by pressing the – and + buttons.

To stop the fire, simply press the power button again and the burner will stop.

If for any reason the fire should be switched off, either intentionally or unintentionally, no attempt should be made to re-light the gas until at least 3 minutes have elapsed.

If you are not intending to use the fire for a long period (i.e. over summer time months), the battery life can be extended even more by sliding the white isolator switch to the left (away from the On position to (O)).



Handset

Ensure the Power Isolator Switch on the front corner of Fire Control is in the on position (I).

Note: For safety reasons a button must be pressed and released for the command to be recognised. Keeping hold of the button when pressing (unless otherwise instructed) will not be recognised as a command press.

Grasp around the handset to unlock its functions. The green unlock light will illuminate to show when the handset is unlocked and ready to accept commands. (N.B. Keep a grip of handset to keep it unlocked, to continue to operate the command buttons.)

Mode - MAN (Manual), Zzz (Snooze), thermostat or timed.



Fig. 16

Power button – To start the fire, (after ensuring the fire control is turned on as described above), with one hand grasp around the rear of both sides of the button area control. The green unlock light will illuminate. Keep the handset held to keep the control unlocked, to enable operation of the buttons. Then with the other hand touch and hold a finger on the power button for about 3 seconds. A short beep and a flash of the unlock light will happen upon touching. When the word “pilot” appears at the bottom left hand corner of the display, immediately release the power button. The Fire should be lit within a few seconds.

(N.B. If power button is held for more than a few seconds after second flash/beep/word pilot appears, the command is ignored for safety reasons. Similarly if it is released too soon before the word “pilot” appears, the command would also be ignored).



Operating instruction (Detailed)

THE HANDSET AND CONTROLS SHOULD ALREADY BE PAIRED AND THE DAY AND TIME SET CORRECTLY.

SHOULD ANY ADJUSTMENTS BE NECESSARY SEE INSTRUCTIONS BELOW:

Setting the time

Following pressing “SET” at pairing above, the display will be as shown, as the time is not set yet and will progress automatically to the next screen shown below.

Note: the legend at the bottom shows the battery condition of both the batteries in the hand set and in the fire control alternately. RC = Remote Control handset and FC = Fire control. The control is designed to get the most out of the batteries but when eventually the display shows they are spent (when the battery legend is a empty area, we recommend you change the batteries in the handset before they are flat, to avoid having to re-program the time of day in again.

N.B. Pairing is not lost, even if the batteries are removed or flat.



Fig. 17

Setting the display for 12 or 24 Hour display

As always when pressing the remote control buttons keep the control held to keep the green light on and therefore handset safety feature, unlocked. The H indicates that it is time to set the timer to either 24 hour display or 12 Hour (AM or PM) display. Press the + or – button on the handset to toggle between the two settings. When you are ready to confirm the setting you want press the “SET” button to progress to setting the day of the week.



Fig. 18

Setting the day of the week

Press and release the + and – buttons until the correct day of the week is shown on the display. (Mo = Monday, Tu= Tuesday, We=Wednesday, Th=Thursday, Fr=Friday, Sa= Saturday and Su=Sunday).

Press “SET” to accept the day of the week and to progress to setting the Hour of the day.

Note: Whilst doing this setup pressing “SET” advances to the next display and pressing “MODE” will return you to the previous display setting.



Fig. 19

Setting the Hour

Press and release the + or – button to change the hour to the correct hour and press set to store and to move to setting the minute. Repeat this for setting the minutes.



Fig. 20

Setting the temperature display to Celsius or Fahrenheit.

Press and release the + or - button to toggle between C and F. When the display shows the desired symbol, press and release the “SET” button to store.

As the important settings above have now been done. Press and hold (not releasing straight away) the “SET” button for a few seconds and this will exit the setup menu.

The control is now ready for use with the Fire Control.



Fig. 21



Paging the handset

If you have misplaced the handset you can page it by pressing the + button only on the fire control for around 5 seconds. The handset will flash and make a noise to help you to locate it. Once you pick up the TESC it knows you hold it and so the sound stops. The flashing and sound will last for 60 seconds each time the handset is paged as described. If not found in 60 seconds, page again and so on.

NOTE: Press “+” button ONLY, NOT “+” and “-” together. This will break the handset pairing and have to reset handset to factory state and pair again.

Advanced settings Menu

In the event that you may want to change the other preset settings of the control features. Do not do a long press and hold above but a normal short press and release will take you into the advanced settings area.

Advanced settings options are:-

- Back light –
 - A = Automatic (default setting). The back light comes on in the dark but not in the light.
 - 0 = Light never comes on.
 - 1 = Light comes on when ever handset is unlocked.
- Display contrast – 8 levels from 0 to 7 (default level 4) .
- P = pairing with other devices other than the fire control. The hand set can pair with other modules to:-
 - L= Operate an electric light – which is the dimmable in 9 steps
 - F= operate an electric fan –which can have 9 speed levels
 - A= operate an auxiliary contact to operate another device.

Other Modes than Manual Mode

Depending upon the model of Fire your handset maybe enabled to have some automatic features, namely, Thermostat mode, timed thermostat mode and snooze mode. Snooze mode can be selected to work with in conjunction with either manual or thermostatic modes. You can switch between modes at any time with the handset unlocked by pressing and releasing mode button to toggle between modes.

Note: If at any time the power button is pressed during operation, this will stop the fire and exit any automatic mode and return the handset to manual (MAN) operation mode.

Factory Reset of Display Handset (to enable handset to be paired again)

To reset a handset to factory conditions to enable it to be paired with a new control. Hold the handset to unlock. Press and hold set until handset beeps and release the set button. PROG will be at the top left corner. Press and release the mode button until the word SETUP is flashing in the top right corner.

Press and release SET to enter the SETUP menu.

Press and release the set button around 9 times until you see CA0 on the display.

Press then release the + (or – button) to change the display to CA1 and press and release the SET button again.

The word TESC will appear in the window to show that this handset is now reset and ready to pair again.

Snooze mode in manual operation

Snooze mode is a time period you can set which will turn off the fire after a certain time period has elapsed.

The snooze time period can be set before or during manual operation of the fire. Hold the handset to unlock as described previously and press the mode button as many times as necessary until the word MAN and the Zzz symbols are flashing at the top of the display. Press and release the set button and this will put the control into Manual snooze mode.

The default time period for the snooze time period is 1:00 hour. Pressing the set button again will show you the snooze time period remaining. This can be adjusted by pressing the “+” or “-“ buttons. The timer period that can be set is from 1 minute to 4:00 hours.

After adjusting the time, press set again to enter the time setting required (or if left for a few seconds this time is now stored and used).

Once this countdown timer has reached zero the fire will turn off (as if you had pressed off manually, it does not recycle).



Snooze mode in Thermostatic mode

The same thing as above can be done before or during a thermostatic mode operation (see below).

Thermostatic mode only

The handset has within it a thermostat sensor and this can be set so the fire will heat the room to match the temperature set in the handset.

There are 3 temperature types that can be set:-

- Day mode temperature that has a sun symbol on the display – the default temperature is 24 °C
- Night temperature that has a half moon symbol on the display- the default temperature setting is 18 °C
- frost protection that has a snowflake symbol on the display – the default temperature setting is 5 °C

Hold handset and press and release the mode button several times as necessary until the display has a thermometer symbol flashing at the top of the display. Press the set button to enter this mode. Press the set button again to see the temperature setting that is set and the mode (the default is 24 C) and on the left of the display is a sun symbol showing it's the day temperature.

If a different set temperature is required, while the display is showing this set temperature , press the + and – buttons to alter the setting. When finished either press set or leave and after a few seconds the new setting will be accepted and the display will return to the time of day screen.

On the anniversary of the net minute of the clock, the set temperature will be compared to the actual temperature displayed on the handset(i.e. the room ambient temperature around the handset).

Note: If at any time the power button is operated during Thermostat mode, the control will cancel any thermostat operation and return the control to manual mode.

For ease of setting there are two other modes that can be selected as stated above. Night mode (moon symbol) and frost protection setting (a snow flake). These can be selected (and adjusted if necessary) by pressing set then mode while in thermostat mode. Pressing mode button toggles through from day to frost modes.

Note: As stated in an earlier section, snooze function can also be operated in conjunction with thermostat mode. The thermostat symbol and the Zzz symbol will be on together when in this mode.

Pairing the Handset to the Fire Control

Should the handset fail to operate the fire control, it may need to be re-paired with the system.

The handset must be within 1 metre (3 feet) of the fire when pairing.

After fitting the batteries as above (and with the power isolator slide switch on the TESC Fire control put in the on position), simultaneously press and hold the – and + buttons on the fire control (i.e. not the handset) until the handset makes a noise and the display shows the pattern as shown here.

Hold the handset in one hand so your fingers wrap around the back of the operating buttons area of the handset. A green unlock light will illuminate when the handset has detected your hand. The green light must be illuminated in this way for any of the command buttons to accept commands to operate the fire control.

While the display is as shown, and holding the handset as described, press the “SET” button with the other hand to finish off the pairing of the handset to the Fire Control and to enter the setup the time of day on the handset.

N.B. If the display returns to the one shown above with the word “TESC” shown, then too much time has passed before pressing “SET” and so the handset has not paired yet. Simply repeat pairing again.

N.B. Only ever press “+” and “-” buttons together when pairing handsets. If done afterwards this will break the pairing made and a factory reset of the handset will need to be performed, see Factory Reset of Display Handset later on in the instructions.



Fig. 22



24 Hour Day timer Snooze Timer

The display handset software has been updated in response to listening to customers and the need for a where possible to meet their needs. This section covers the 24 hour Day timer (also known as the snooze timer)

Note: The handset is backward compatible so it can operate all TESC valves that have been made to-date.

The 24 hour (snooze mode) timer can operate in both manual and Thermostatic Modes.

Snooze mode is a time period you can set which will turn off the fire after a certain time period has elapsed.

Snooze mode in “manual” operation

The snooze time period can be set before starting the fire manually or during manual operation of the fire.

Hold the handset to unlock the keypad and press and release the “mode” button once until the word MAN and the Zzz symbols are flashing at the top of the display.

Press and release the “set” button and this will put the control into Manual snooze mode. Pressing the set button again will show you the snooze time period remaining, 1:00 and co will appear in the display which signifies the count down time remaining is 1 hour (the default time period). To see the time remaining at any time do a short press and release of the mode button. To adjust the time use the “+” or “-” buttons.

The time period that can be set is from between 1 minute to 24:00 hours.

After adjusting the time, press set again to enter the time setting required (or if left for a few seconds this time is now stored and the display will return to the time of day.

Once this countdown timer has reached zero the fire will turn off (as if you had pressed off manually, it does not store the time period set previously, it will default to 1:00 when selected again). The control returns to off manual mode and snooze mode is disabled automatically at the end of the countdown.

Snooze mode in Thermostatic mode

Snooze mode in thermostatic mode can be set before the fire is started or after the fire is started. Note: Depending on your fire design, the thermostat may regulate between low and high on the main burner and never turn the fire off and restart itself while unattended. The snooze timer additional feature will always turn the fire off at the end of the countdown timer period and cancel any thermostat mode.

Hold the handset to unlock the keypad and press and release the “mode” button 3 times until the word thermostat symbol and the Zzz symbols are flashing at the top of the display.

Press and release the “set” button and this will put the control into Thermostatic snooze mode. Pressing the set button again will show you the snooze time period remaining, 1:00 and co will appear in the display which signifies the count down time remaining is 1 hour (the default time period). To see the time remaining at any time do a short press and release of the mode button. To adjust the time use the “+” or “-” buttons.

The time period that can be set is from between 1 minute to 24:00 hours.

After adjusting the time, press set again to enter the time setting required (or if left for a few seconds this time is now stored and the display will return to the time of day.

From the time of day screen, pressing the set button twice will show the set temperature of the thermostat. This can then be adjusted with the + and – buttons (the default temperature is 24 C).

The fire will continue to run and regulate thermostatically until the end of the set snooze time and at the same time cancel all thermostatic modes and return the handset to manual mode.



It is recommended that this appliance is serviced at regular 12 monthly intervals. The chimney or flue should also be checked regularly to ensure that all products of combustion are entering the flue and there is no excessive build up of soot.

It is the users responsibility to ensure that the appliance is kept in a clean serviceable condition.

To remove the glass door

1. Remove the magnetic trim from the front of the stove (Fig. 23).
2. Remove the two screws at the bottom of the glass door panel (Fig. 24).
3. Hinge the door upwards by approximately 30° (Fig. 24).
4. Slide the door to the right by 10mm and remove the door from it's hinges (Fig. 25).
5. Clean the glass with a damp cloth. For stubborn stains use a proprietary cream cleaner or ceramic hob cleaner.

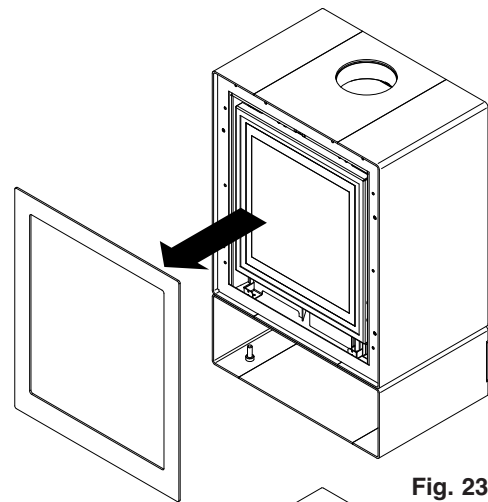

Fig. 23

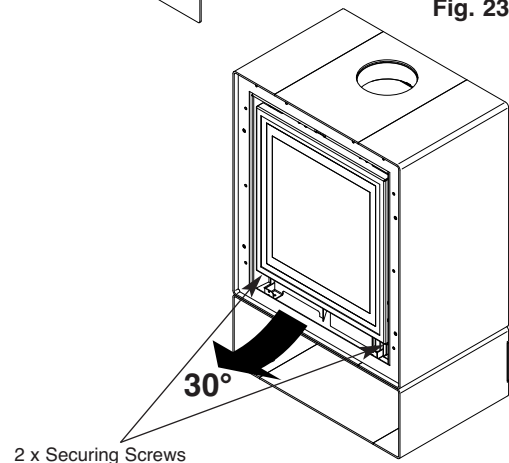

Fig. 24

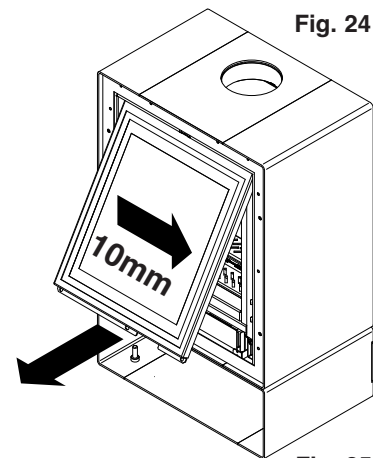

Fig. 25

Ceramic Components and Fuel Bed

Debris from any source should be removed with a soft brush. Please ensure that any debris including soot deposits are removed from the appliance and not left on the fuel bed.

It is recommended that the user should, on a regular quarterly basis, carefully remove all ceramic components and thoroughly clean the stainless steel burner and the pilot assembly.

Any build up of debris in this area could affect the operation of the appliance (Fig. 26).

NOTE: It is common to find surface cracks in the ceramic components. This is due to the expansion and contraction of the ceramic fibres caused by the intense heat that the burner generates. The cracks will not affect the safe operation of this appliance. However great care must be taken when handling the ceramic components as they will break if handled incorrectly. Do not use a vacuum cleaner to clean the ceramics.

Radiant Box Ceramic Liners - Use only a soft brush to remove any soot deposits from the ceramic liners during cleaning as this is the only method that can be used to remove deposits. The ceramic liners are very delicate and should be treated accordingly.

5. Reassemble in reverse order.

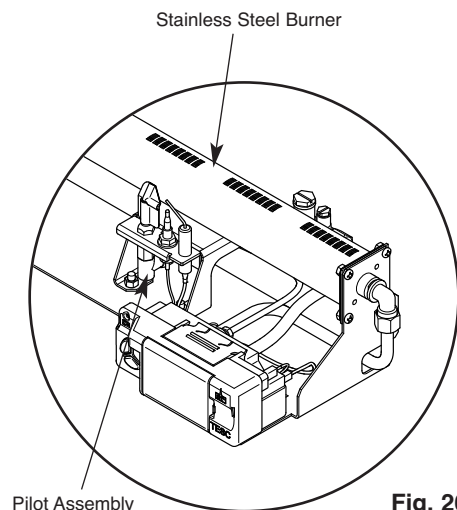

Fig. 26

LOG LAYOUT INSTRUCTIONS



CAUTION: The logs are extremely fragile and must be handled accordingly. Gloves should be worn and any inhalation of dust should be avoided. The logs must be kept away from children at all times. Never put additional logs on the fire. Never use logs other than those originally supplied, or genuine Legend Spare Parts.



1. Place the burner grille into position.



2. Place the front ceramic panel into position.



3. Arrange the slate ceramics onto the burner cover plate. ENSURE THAT THEY DO NOT COVER THE BURNER.



4. Place the rear log at the back of the burner grille.



5. Place the front log onto the front ceramic panel.



6. Place the small log on top of the rear log as shown.



9. Place the remaining logs as shown in the photographs below.



7.



8.



9.



10.



11.



12.

It is very important that all the logs are used and arranged as shown in order to achieve the desired flame picture. It may be necessary to remove some or all of the logs to clean them at some time. Cleaning must only be done using a soft brush.



Non Display handset with pilot burner

If the fire does not start at the first attempt it may retry several times to do so. At the end of trying if it cannot ignite the burner; it will show a RED light on the handset and on the fire control and stop the fire.

- If the fire does not light first time, allow fire to cool and then repeat lighting fire up to 10 times, as it may only be a temporary reason that will clear after a few attempts..
- Reset the fire control by pressing the handset as if you were doing a normal start. This will clear the red light and allow another subsequent restart attempt.
- If the fire does not light, replace all the batteries in the handset and the fire control, (5 x AA Alkaline in total, with batteries that do not leak) with new and known to be good batteries and repeat the above starting of the fire.
- While replacing the batteries, check that the battery contacts are not contaminated with anything that may have leaked out of the batteries that may have damaged the contacts.
- If the fire still fails to light check to see if the pilot flame on the pilot burner, is lighting during the starting sequence. If not then clean the pilot as described in Cleaning the pilot section of the booklet.
- Check to see if there is a spark appearing on the pilot spark plug and check to see if there is any contamination around it that might be preventing the ignition spark from happening.

Display handset with pilot burner

As above except instead of the red LED light on the handset there will be a letter E and a to digit number where the time is usually displayed. Do the same actions as above to try and resolve the reason for non ignition of the burner.

If you cannot resolve the problem, then call: 01254 695244.

GUARANTEE

Your appliance is guaranteed for one year from proof of purchase. Should the appliance prove defective within that period we agree to repair or replace (at our discretion) the component or appliance provided that:

1. The user can produce a receipt for proof of purchase/installation.
2. The appliance has been supplied by an authorised stockist and has been installed by a qualified installer, all installation and operating instructions have been strictly adhered to.
3. No alterations have been carried out on the appliance or component parts without our written consent.
4. The appliance has not been used for any purpose other than those intended.
5. The appliance has not been damaged accidentally or due to fair wear and tear.

Guarantee claims should be made through your appliance supplier. The Guarantee is restricted to UK Mainland and is additional to your statutory rights.

