

Containment systems for the prevention of pollution

*Secondary, tertiary and other measures
for industrial and commercial premises*





Who we are

Established in 1960, CIRIA is a highly regarded, industry-responsive, not for profit research and information association, which encompasses the construction and built environment industries.

CIRIA operates across a range of market sectors and disciplines, providing a platform for collaborative projects and dissemination by enhancing industry performance, and sharing knowledge and innovation across the built environment.

As an authoritative provider of good practice guidance, solutions and information, CIRIA operates as a knowledge-base for disseminating and delivering a comprehensive range of business improvement services and research products for public and private sector organisations, as well as academia.

How to get involved

CIRIA manage or actively participate in several topic-specific learning and business networks and clubs:

- **Core membership**
Allows your employees to assist with the development of and access to good practice guidance, formal networks, facilitation, conferences, workshops and training.
- **Associate membership**
Allows your employees to access CIRIA's services. Members are able to access exclusive content via the CIRIA website.
- **CIRIA Books Club**
Members can buy most CIRIA publications at half price and can attend a range of CIRIA conferences at reduced rates.
- **The CIRIA Network**
A member-based community where clients and professionals meet, develop and share knowledge about specific topics relevant to construction and the built environment.
- **Project funding**
Project funders influence the direction of the research and gain early access to the results.
- **CEEQUAL**
CIRIA co-manages this environmental award scheme, which promotes environmental quality in civil engineering and infrastructure projects.
- **LACL (Local Authority Contaminated Land Network)**
LACL helps local authorities address responsibilities under Part IIA of the Environmental Protection Act 1990.
- **EMSAGG (European Marine Sand and Gravel Group)**
CIRIA provides secretariat support to EMSAGG, including management of the Group's conferences, workshops and website and producing its newsletter.
- **LANDFoRM (Local Authority Network on Drainage and Flood Risk Management)**
A platform for sharing knowledge and expertise in flood risk management and sustainable drainage.
- **BRMF (Brownfield Risk Management Forum)**
Promoting sustainable and good practice in brownfield projects in the UK.

Where we are

Discover how your organisation can benefit from CIRIA's authoritative and practical guidance – contact us by:

Post	Griffin Court, 15 Long Lane, London, EC1A 9PN, UK
Telephone	+44 (0)20 7549 3300
Fax	+44 (0)20 7549 3349
Email	enquiries@ciria.org
Website	www.ciria.org (for details of membership, networks, events, collaborative projects and to access CIRIA publications through the bookshop)

Containment systems for the prevention of pollution

*Secondary, tertiary and other measures
for industrial and commercial premises*

I L W Walton SLR Consulting



Griffin Court, 15 Long Lane, London, EC1A 9PN

Tel: 020 7549 3300

Fax: 020 7549 3349

Email: enquiries@ciria.org

Website: www.ciria.org

Summary

This guidance has been developed to assist owners and operators of industrial and commercial facilities storing substances (inventories) that may be hazardous to the environment.

It provides guidance on identifying the hazards, assessing the risks and mitigating the potential consequences of a failure of the primary storage facility and/or the combustion of its contents. A three-tier risk assessment methodology is introduced with recommendations for different 'classes' of construction for each.

It is applicable to the containment of a wide range of inventories and to all sizes of site from small commercial premises with a single storage tank, through to large chemical or petrochemical sites. It also applies to warehouses storing hazardous inventories.

Guidance is provided on the design, and construction of new secondary containment systems and also the inspection, maintenance, repair, extension and upgrading of existing installations.

Containment systems for the prevention of pollution. Secondary, tertiary and other measures for industrial and commercial premises

Walton, I L W

CIRIA

C736

Con195

© CIRIA 2014

ISBN: 978-0-86017-740-1

British Library Cataloguing in Publication Data

A catalogue record is available for this book from the British Library

Keywords Pollution control, containment, COMAH, EPA, incident, fire, spill, risk, bund, lagoon, secondary containment, tertiary containment	
Reader interest Site operators, regulatory bodies, system designers, contractors, equipment suppliers, local authorities, fire service, insurers	Classification Availability Unrestricted Content Guidance based on current good practice Status Committee guided User Site operators, regulatory bodies, system designers, contractors, equipment suppliers, local authorities, fire service, insurers

Published by CIRIA, Griffin Court, 15 Long Lane, EC1A 9PN, UK

This publication is designed to provide accurate and authoritative information on the subject matter covered. It is sold and/or distributed with the understanding that neither the authors nor the publisher is thereby engaged in rendering a specific legal or any other professional service. While every effort has been made to ensure the accuracy and completeness of the publication, no warranty or fitness is provided or implied, and the authors and publisher shall have neither liability nor responsibility to any person or entity with respect to any loss or damage arising from its use.

All rights reserved. No part of this publication may be reproduced or transmitted in any form or by any means, including photocopying and recording, without the written permission of the copyright holder, application for which should be addressed to the publisher. Such written permission must also be obtained before any part of this publication is stored in a retrieval system of any nature.

If you would like to reproduce any of the figures, text or technical information from this or any other CIRIA publication for use in other documents or publications, please contact the Publishing Department for more details on copyright terms and charges at: publishing@ciria.org/Tel: 020 7549 3300.

Foreword

The original CIRIA R164 *Design of containment systems for the prevention of water pollution from industrial incidents* (Mason *et al*, 1997) was written primarily for new construction. However, many of the principles have been applied to good effect on existing sites.

The guide has been revised and updated to reflect changes in legislation, construction design and practice and lessons learned from recent incidents (particularly Buncefield), near misses and inspections. Analysis of this and other incidents identifies several causes, future occurrences of which can be avoided by following the guidance in this document.

In updating the guide, it became clear that the inspection, maintenance, repair, extension or upgrading of containment systems (particularly in cases of change of use) represents a large proportion of the work currently being undertaken. The revision therefore includes a new section covering these issues, such as actions to take on existing facilities, to ensure they continue to perform satisfactorily.

The revised guide also differs from the original by excluding the model design calculations and placing greater emphasis on the need for structures to be professionally designed and constructed.

Acknowledgements

This guide was originally published by CIRIA in 1997 as R164 *Design of containment systems for the prevention of water pollution from industrial incidents*. The authors were Paul Mason, Jim Amies, Phil Edwards, Gordon Rose and Gopal Sangarapillai.

Author

Ian Walton BSc (Hons) MSc DIC CEng MICE

Ian Walton is a technical director at SLR Consulting Limited. He is a chartered civil engineer with over 30 years broad environmental consultancy experience working for both public and private sector clients. He has been responsible for managing and directing a diverse range of commissions including those in the public health, waste management, infrastructure and general development sectors. Ian is also regularly called upon to provide expert evidence in relation to flooding and drainage issues.

Project steering group (PSG)

Following CIRIA's usual practice, the work was guided by a project steering group (PSG) comprising:

Irene Anders	Scottish Environmental Protection Agency
Jackie Coates	Chemical Industries Association
David Cole	Ecovalve
Michael Cooper	Chemical Business Association
Peter Davidson	UK Petroleum Industry Association
Chris Dickinson	Environment Agency
Ray Dickinson	MoD Defence Infrastructure Organisation
Martyn Emberson	Chief Fire Officer's Association
Nicola Fagin	Bureau Veritas
Owen Jenkins	CIRIA
Lee Kelly	CIRIA
Bruce McGlashan	Environment Agency
Mike Nicholas	Environment Agency
Peter Robery (chairman)	CH2M Hill
Barrie Salmon	Tank Storage Association
Mark Scanlon	Energy Institute
Roy Simpson	Basis Registration Ltd
Mike Summersgill	CIWEM
Ian Walton	SLR Consulting

Project funders

The project was funded by the Environment Agency and industry in-kind contributions.

CIRIA Project manager

Owen Jenkins

Corresponding members/technical consultees

Tony Brown	Federation of Petroleum Suppliers
John Davies	Sir Robert McAlpine
Stephen Gibson	Ramboll
Mark Maleham	Environment Agency
Guy Marlair	Ineris France

CIRIA thanks the individuals and organisations who provided photographs, case studies and other relevant information and to Lawrence Dowson, PPG Coatings and Graham Vaughan, Abbey Metal Finishing Ltd for hosting site visits.

Why you should read this guide

Following the good practice in this guide will help you minimise the pollution risks associated with your operations. However, it will also help with the management of risks and opportunities at corporate level that might include:

✓ **Penalties, liabilities and reputational issues**

Ineffective containment of pollutants can result not only in environmental harm but can also have a severe effect on the company concerned. In the past, fines imposed for pollution offences were trivial compared with the cost of installing protective measures. However fines have been increased significantly and in July 2010 five companies were fined a total of £9.5m for their part in the Buncefield catastrophe, a disaster that it is estimated had a total cost exceeding £1 billion.

✓ **Corporate governance**

Corporate governance demands that asset owners understand the value of their portfolio, including future maintenance and risks to operation. This is clearly applicable to the containment systems covered in this guidance.

✓ **Corporate social responsibility (CSR)**

While companies regard legal compliance as a major priority, leading organisations are now striving to improve their reputational image and are becoming more open in the publication of information relating to their environmental performance.

Lessons learned from past incidents and near misses have illustrated that many of the preventative measures are relatively straightforward to implement as illustrated on the following pages.

Lessons learned from incidents

This publication provides guidance on the measures that site operators can take to minimise the risk of pollution from leaking or burning substances stored on site. Many of these measures are relatively straightforward in terms of how sites are designed, operated and maintained. The examples from two key references shown in the following box illustrate some of the consequences that have arisen from not incorporating these measures.

Major accident to the environment (MATTE): UK case studies of incidents and near misses 1999–2010 (HSL, 2012)

- 1 Serious environmental harm is most frequently associated with release of liquids to ground and water, as opposed to aerial dispersion of pollutants.
- 2 There is a need to consider ... the quantities of firewater that are likely to be produced throughout the incident (not just first response), the rate at which runoff will be generated and how this will be successfully managed and retained.
- 3 Loss of liquid material to the environment via hitherto unknown pathways, or because of the availability of pathways due to a lack of impermeable barriers, was common to a number of cases:
 - a failings in oversight were underlying factors ... typically a failure to foresee and plan accordingly
 - b failure to adequately manage ageing plant continues to be highlighted as a significant underlying causal factor.

Buncefield: Why did it happen? The underlying causes of the explosion and fire at the Buncefield oil storage depot, Hemel Hempstead, Hertfordshire on 11 December 2005 (HSE, 2011)

- 1 The bunding at Buncefield had many flaws, which caused large volumes of fuel, foam and firefighting water to leak out of the bunds. Bunds were not impermeable and not fire resistant. The bunding was unable to handle the large volumes of firewater involved in the incident.
- 2 Generally, the concrete performed well in resisting the burning fuels but the bunds failed badly at the joints and walls where pipes penetrated them.
- 3 One of the bunds at Buncefield contained metal waterstops within joints. Even though this bund was exposed to a bund pool fire and tank fires, the joints performed well and did not leak significantly.
- 4 Other bunds had plastic waterstops with metal plates over the inside face of the joint. These joints also maintained their integrity as the plastic waterstop and other joint material was protected from thermal impact by the metal cover plate.
- 5 Three bunds performed particularly badly. The joints (floor and wall joints) did not contain waterstops. During the fire the sealant and other joint materials (which were not fire resistant) were badly damaged. Many of the joints leaked allowing fuel, foam and firewater to flow onto the site roadways.
- 6 One bund was constructed with tie bars penetrating through the bund and although they were plugged and grouted, they were unable to resist the impact of the fire. Holes opened up, which were further pathways for leakage of fuel, foam and firewater from the bund.
- 7 Many of the bunds had pipes penetrating through walls and floors, and failures at these points meant the bunds could no longer retain liquids. Broadly, there were three ways loss of integrity occurred:
 - i catastrophic failure of the walls at pipe penetrations, likely due to thermal expansion of the pipework
 - ii some of the product pipes leading from the tanks ruptured and leaked so that there was an escape of fuel via damaged pipes through the walls and out of pipes in unbunded areas
 - iii loss of seal between pipes and walls.
- 8 There was virtually no tertiary containment in place. Containment systems outside the bunding amounted only to the site's drainage systems, designed for rainwater and minor spills and losses of product, which would flow to interceptors and the site's effluent treatment plant. The drainage was not designed for any large-scale releases from bunds, such as those that occurred. Specific flaws included:
 - there was no kerbing or boundary wall/mound to keep liquids on site and direct them into drainage systems. Once released, liquids could flow anywhere
 - the capacity of the drains and the lagoon was too small
 - some of the drains were 'perforated' so that a 'back-up' of liquids would cause their release through underground perforations
 - the liner of the firewater lagoon was susceptible to fire damage and to damage from debris from the explosion
 - one lagoon was intended as a firewater supply, but was rendered useless as it received fuel draining from the site. It flooded the fire system pump house when it overflowed
 - there was a dependence on pumping liquids, which as a process is vulnerable to, for example:
 - inadequate pumping capacity
 - failure of pumps on loss of power
 - inability to use pumps following release of flammable vapour
 - some areas of unmade ground were not protected from liquids and one such area of the site included a soakaway
 - the effluent treatment plant included soakaways that were not identified in the safety reports or emergency plans.

Collectively these flaws allowed large volumes of fuel, foam and firewater to leave the site.

More information on the Buncefield incident can be found at: www.buncefieldinvestigation.gov.uk

Overview of this guidance

The guidance is divided into 12 chapters and grouped into three parts, summarised here:

Part	Chapter	Contents
1	1	Introduction
	2	Risk assessment and classification* of secondary and tertiary containment systems
	3	Containment options
	4	Containment system capacity
2	5	Existing installations
3	6	Introduction to bunds
	7	<i>In situ</i> reinforced concrete and masonry bunds
	8	Earth banked containment basins (lagoons), earth bunds and earth floors
	9	Containment tanks
	10	Transfer systems
	11	Sacrificial areas and temporary containment
	12	Repair and upgrading of existing containment facilities

* Note that the key recommendations contained in the guidance with respect to the 'class' of containment are indicated in the margin with the key icon: 

The **key plan** and accompanying text provides a summary of the contents of each chapter and gives examples of the scope of each chapter with reference to particular elements of an idealised facility. It is intended to be used as an aid to the reader in navigating the guidance.

Key plan

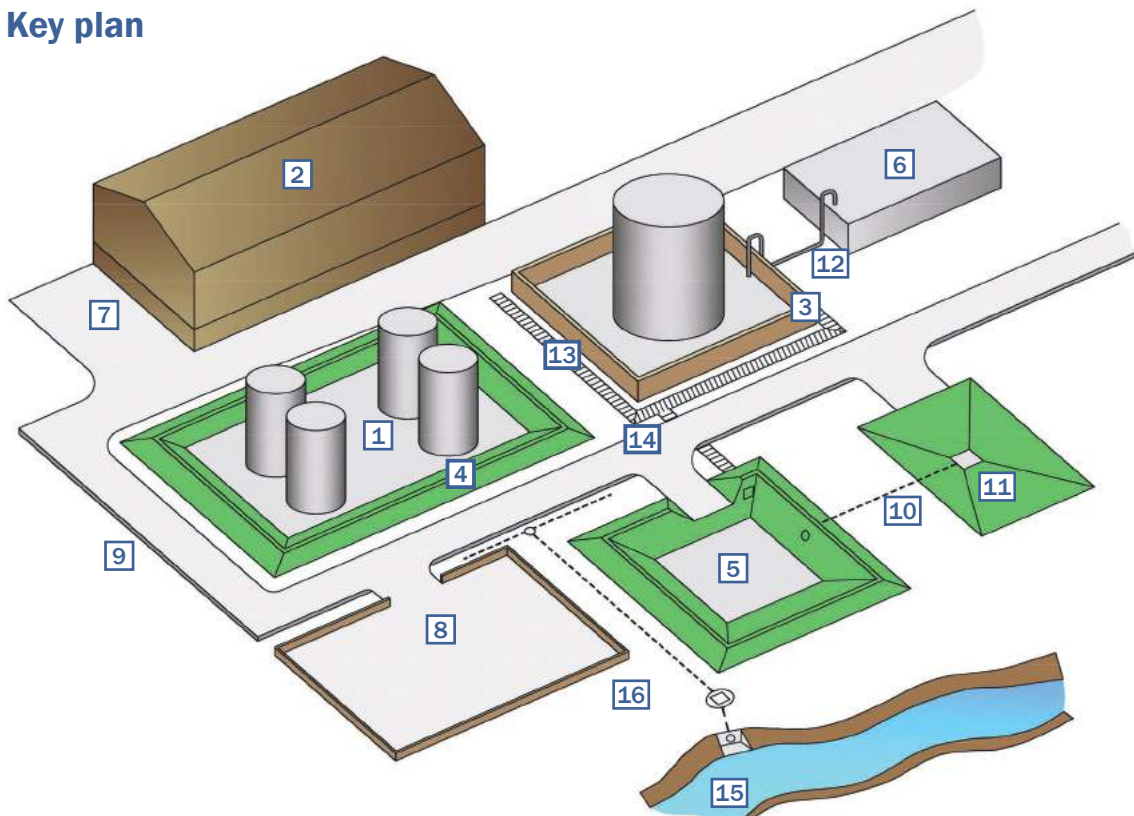

Key plan notes

Chapter 1: Introduction

The introduction sets out the scope of the guidance, provides an overview of the fundamental principles upon which it is based and includes a high-level summary of related guidance and legislation.

Chapter 2: Risk assessment and classification

At the core of the guidance is a risk assessment and classification methodology that determines the 'class' of containment required, ie class 1, 2 or 3. The class then determines the design and specification requirements for the secondary containment system.

Chapter 3: Containment options

This chapter defines primary, secondary and tertiary containment and a number of system types – local, remote and combined.

Examples:

- tanks, vessels and associated pipework [1] provide the primary containment. The primary containment may also be located within a warehouse [2]
- secondary containment can be provided by bunds constructed from reinforced concrete [3] or earth [4], by lagoons [5] or by tanks [6]. Warehouse walls can also be designed to provide secondary containment [7]
- tertiary containment can be provided by a number of means including lagoons [5], sacrificial areas such as car parks [8] and providing storage on the surface of roadways using containment kerbs [9]
- local containment is provided locally to the primary containment normally using a bund [4] [5]
- remote containment is provided away from the primary containment using, for example, a lagoon [5] or tank [6]. Transferring spilled inventory to the remote containment can be via a gravity drain [10] (as shown by the example of a loading bay [11]) or pumped
- combined containment uses both local containment and remote containment. The example shows a local containment (a bund [3]) with additional remote containment (a tank [6]) connected via a pumping main [12].

Chapter 4: System capacity

This chapter describes the process for determining the secondary and site-wide capacity of containment systems based on a combination of the inventory, an allowance for accumulated rainfall and, where appropriate, firefighting and/or cooling water.

Examples:

- secondary containment capacity requirement differs depending if a single tank in a bund [3] or multiple tanks in a bund [4]
- total site-wide capacity is a combination of all the containment capacity including bunds [3] [4], lagoons [5], tanks [6] and other sacrificial and temporary storage areas [8] [9].

Chapter 5: Assessment of existing installations

This guidance recommends that an operator is able to demonstrate that the 'class' of the installation is appropriate to the use to which it is being put. This part of the document provides advice on the classification, inspection, maintenance and modification of existing installations.

Chapter 6: Introduction to bunds

This chapter defines 'bunds' and for each class of containment provides a performance specification and recommendations and guidance on their design and construction.

Example:

- bunds include those constructed in concrete [3] and as earth embankments [4].

Chapter 7: In situ reinforced concrete and blockwork bunds

In situ built reinforced concrete and blockwork walls [3] are probably the most common form of bund construction. This chapter provides advice on the design and specification of this form of construction appropriate to each class of containment with emphasis is on the formation of joints and detailing of pipe penetrations where these cannot be avoided.

Chapter 8: Earth banked containment basins (lagoons) and earth bunds

Where the site topography and the ground and soil conditions are suitable, earth embankments can provide a cost effective means of providing both local secondary containment (earth bunds [4]) and remote secondary containment basins (lagoons [5]).

This chapter provides advice on assessing the suitability of a site, a performance specification and recommendations and guidance on their design and construction appropriate to the class of containment.

Chapter 9: Secondary containment tanks

Secondary containment tanks [6] usually form part of a remote containment system with, depending on the site topography, either a gravity or pumped [4] connection from a sump local to the primary containment, or from a local secondary containment system. The chapter discusses the factors that should be considered in specifying a secondary containment tank and reviews a number of tank types.

Chapter 10: Transfer systems

Transfer systems are the means for collecting and conveying spillage and contaminated water from the primary containment to a remote secondary and/or tertiary containment facility. The transfer system comprises the catchment area local to the primary containment and the conveyance system (pipes networks, culverts, open channels, pumps and pumping mains and even site roads) discharging to the remote secondary containment.

The chapter provides the performance requirements that components of a transfer system should meet to satisfy the overall system classification.

Examples:

- gravity system [10] draining a loading bay (catchment area) [4] to a remote secondary lagoon
- channel drainage [13] draining inventory overtopping (or due to failure of) failure secondary local containment [3] to a lagoon [5] providing (in this example) tertiary containment
- tertiary containment provided by pumping [12] inventory from secondary containment [3] to a tank [6]
- road [14] with high containment kerbs [9] draining inventory overtopping (or due to failure of) secondary containment [3] [4] [7] to a lagoon [5] or sacrificial storage area [8] providing tertiary containment
- during an incident, runoff from drained areas [14] must be prevented from reaching the outfall to river [15] via the surface water drainage system [16] by closing a pollution control valve [17].

Chapter 11: Sacrificial areas and temporary containment

The sacrificial areas are designed to soak up the contaminants by containing the spill within a depth of permeable soil or porous media. The method relies on interception of spills at the source and conveying the contaminated runoff to a remote area. Sites that may be designated for this purpose include car parks, landscaped areas, sports fields etc.

Temporary containment areas provide preventative measures for dealing with exceptional events that cannot be dealt with by the permanent facility and may form part of a site's emergency response procedures.

This chapter provides advice on the design of sacrificial areas and temporary containment.

Examples:

- spills drained by the roadway [16] to a sacrificial area provided by a car park [16]
- roadway [16] with high containment kerb [16] provides temporary storage. Spills prevent from reaching the river [16] via the surface water drainage system [16] by a pollution control valve [16].

Chapter 12: Repair and upgrading of existing installations

This chapter will provide advice on the repair and upgrading of existing installations with reference to other chapters in Part 3 as appropriate. Upgrading of an existing installation may be required following an assessment described by Chapter 5.

Contents

Summary	ii
Foreword	iii
Acknowledgements	iv
Why you should read this guide	vi
Lessons learned from incidents	vii
Overview of this guidance	viii
Glossary	xiii
Abbreviations and acronyms	xix
Key plan	xx
1 Introduction	1
1.1 Objectives	1
1.2 Exclusions	2
1.3 Regulatory context	2
1.3.1 Range of sites	2
1.3.2 Risk	3
1.3.3 Existing sites	3
1.4 Other drivers	3
1.4.1 Penalties, liabilities and reputation issues	4
1.4.2 Corporate governance	5
1.4.3 Corporate social responsibility	5
1.5 UK and EU legislation, international guidance and publications relevant to containment	5
1.5.1 Introduction	5
1.5.2 Control of Major Accident Hazards Regulations (COMAH)	6
1.5.3 EPR (England and Wales) 2010, PPC (Northern Ireland) 2003 and PPC (Scotland) 2012	7
1.5.4 The Control of Pollution (Oil Storage) (England) Regulations (OSR) 2001	8
1.5.5 The European Water Framework Directive (WFD)	8
1.5.6 Other legislation and guidance	9
1.6 Assessing the risk	9
2 Risk assessment and classification of secondary and tertiary containment systems	11
2.1 Introduction	11
2.2 Framework for classification of secondary and tertiary containment	13
2.3 Key elements for determining the site hazard rating	15
2.3.1 Source	15
2.3.2 Pathway	18
2.3.3 Receptors	21
2.4 Overall site hazard rating	24
2.5 Site risk rating	26
2.6 Containment classification system	28
2.6.1 Hazard and risk assessment and design classification	28
3 Secondary and tertiary containment options	31
3.1 Introduction	31
3.2 Containment system types	31
3.3 Local containment systems	31
3.4 Remote containment systems	32
3.5 Combined containment systems	33

3.6	System selection	33
3.7	Site zoning	35
3.8	System reliability	35
4	Containment system capacity	37
4.1	Introduction	37
4.2	Current industry practice	37
4.2.1	The '110 per cent' and '25 per cent' rules	38
4.2.2	The Control of Pollution (Oil Storage) (England) Regulations (OSR) 2001	39
4.2.3	Health and Safety Executive (HSE)	39
4.2.4	Pollution prevention guidelines (PPG)	41
4.2.5	Environmental Permitting Regulations (England and Wales) (EPR) 2010	41
4.2.6	Energy Institute (EI)	41
4.2.7	BASIS recommendations	41
4.2.8	Summary	42
4.3	Method for assessing containment capacity	42
4.3.1	Introduction	42
4.3.2	Volume of inventory	43
4.3.3	Rainfall	43
4.3.4	Firefighting water and firefighting agents	46
4.3.4.1	Introduction	46
4.3.4.2	Allowance for firefighting water in the design of remote and combined systems	47
4.3.4.3	Delivery rates	48
4.3.4.4	ISO/TR 26368:2012 Environmental damage limitation from fire-fighting water runoff	48
4.3.4.5	Fixed firefighting systems	51
4.3.4.6	National guidance document on the provision of water for firefighting	52
4.3.4.7	Conclusions on forecasting firefighting water	52
4.4	Freeboard in bunds and dynamic effects	53
4.5	Summary of retention capacity recommendations	55
5	Existing installations	57
5.1	Introduction	57
5.1.1	Asset management of existing facilities	57
5.1.2	Overview of chapter	57
5.2	Maintenance plans	58
5.3	Risk assessment and classification of containment systems	61
5.4	Baseline survey	62
5.4.2	Volumes of primary, secondary and tertiary containment	64
5.4.3	Nature of material being stored and compatibility with form of construction	66
5.4.4	Potential pathways to sensitive receptors	66
5.5	Assessment of specific construction types	67
5.5.1	Introduction	67
5.5.2	Competence	68
5.5.4	Blockwork/brickwork	68
5.5.5	Reinforced concrete walls (with and without concrete bases)	69
5.5.6	Earth bunds (including earth bases with reinforced concrete and blockwork walls) and liners	73
5.5.7	Remote secondary containment tanks	73
5.6	Integrity of containment systems	73
5.6.1	Joints	73
5.6.2	Penetrations through the containment	75
5.7	In-service performance	76
5.7.1	Details of any linings/coating to the containment	76
5.7.2	<i>In situ</i> load testing	77

5.7.3	Watertightness	77
5.7.4	Containment tanks	77
5.7.5	Leak detection systems (if installed)	77
5.8	Gap analysis	78
5.9	Key recommendations	78
6	Introduction to bunds	80
6.1	Definition of bund	80
6.2	Overview of design and performance requirements	81
6.3	Design considerations	84
6.3.1	General arrangement	84
6.3.2	Drainage and leakage detection	87
6.3.3	Pipework and associated equipment	88
6.3.4	Capacity	89
6.3.5	Retention period	89
6.3.6	Impermeability	89
6.3.7	Testing for leakage	90
6.3.8	Strength	90
6.3.9	Durability	93
6.3.10	Structural independence	94
6.3.11	Accessibility	94
6.4	Summary of general arrangement recommendations	94
7	<i>In situ</i> reinforced concrete and masonry bunds	96
7.1	Introduction	96
7.2	<i>In situ</i> reinforced concrete bunds	96
7.2.1	Introduction	96
7.2.2	Design approach	97
7.2.3	Crack control	97
7.2.4	Joint detailing	97
7.2.5	Penetrations	99
7.2.6	Joint sealants	100
7.2.7	Surface protection systems	100
7.2.8	Concrete production	100
7.2.9	Shuttering and formwork	101
7.2.10	Reinforcement fixing	101
7.2.11	Slip membrane	101
7.2.12	Waterstops and joints	102
7.2.13	Concrete placing and compaction	102
7.2.14	Concrete finishing	103
7.2.15	Concrete curing	103
7.2.16	Typical reinforced concrete bund details	103
7.3	Reinforced masonry bunds	103
7.3.1	Introduction	103
7.3.2	Forms of construction	104
7.4	Prefabricated bunds	104
7.4.1	Introduction	104
7.4.2	General description	105
7.4.3	Specification and procurement	105
7.5	Installation	105
7.5.1	Testing	106
7.5.2	Maintenance	106
8	Earth banked containment basins (lagoons), earth bunds and earth floors	107
8.1	Introduction	107
8.2	Design criteria for lagoons and earth bunds	108
8.2.1	Soil permeability limits	108

8.2.2	Stability	109
8.2.3	Durability	109
8.3	Classification of containment	110
8.4	Capacity	111
8.5	Location of lagoons in relation to receptors	111
8.6	Ground investigation	111
8.6.1	Desk study	111
8.6.2	Site reconnaissance	111
8.6.3	Soils investigation	112
8.7	Soil permeability	112
8.7.1	Permeability assessment	112
8.7.2	Effect of soil consolidation	113
8.8	Design and construction	113
8.8.1	Design	113
8.8.2	Construction	113
8.9	Embankment and lagoon linings	114
8.10	Anchorage and protection	118
8.11	Pipe entries through embankments	119
8.12	Leakage detection for class 3 lagoons and bunds	120
8.13	Post-construction	120
8.14	Maintenance	120
9	Containment tanks	122
9.1	Introduction	122
9.1.1	Capacity	123
9.1.2	Freeboard	123
9.1.3	Leak detection	123
9.1.4	Inspection	123
9.1.5	Firefighting water reservoirs	123
9.2	Tanks constructed above ground	123
9.2.1	Suitable tank systems	123
9.2.2	Buildings and structures for agriculture – storage tanks and reception pits	125
9.2.3	Pressed steel sectional rectangular tanks	125
9.2.4	Site built, vertical cylindrical, flat bottomed, above ground, welded steel tanks	126
9.2.5	Oil storage tanks to BS 799-5:2010	126
9.2.6	Glass reinforced plastic (GRP) tanks and vessels for above ground	127
9.2.7	<i>In situ</i> reinforced concrete tanks	127
9.2.8	Precast concrete tanks	127
9.2.9	Reinforced masonry tanks	128
9.3	Tanks constructed below ground level	128
9.3.1	Introduction	128
9.3.2	Tank systems for use below ground	129
9.3.3	<i>In situ</i> reinforced concrete below-ground tanks	129
9.3.4	Deep shaft tanks	129
9.3.5	Tanks formed with embedded walls of steel sheet piling	129
10	Transfer systems	131
10.1	Introduction	131
10.2	Categorising catchment areas	132
10.2.1	Categories of waste	132
10.2.2	Site zoning	133
10.3	Gravity and pumped transfer systems	133
10.3.1	Gravity systems	134
10.3.2	Pumped systems	134
10.4	Transfer system classification	134
10.5	Catchment area design	135

10.6	Design flow	137
10.6.1	Failure of the primary storage vessel	137
10.6.2	Tanker offloading and loading facilities	138
10.6.3	Attenuation	138
10.7	Open channel design	138
10.8	Pipework for transfer systems	139
10.9	Flame arrestors	143
10.10	System testing	143
11	Sacrificial areas and temporary containment	144
11.1	Introduction	144
11.2	Examples of sacrificial areas	144
11.2.1	Car parks, sports fields and other landscaped areas	144
11.2.2	Areas surrounded by vertical cut-off walls	145
11.3	Emergency plans for sacrificial areas	146
11.4	Emergency and temporary containment measures	146
11.4.1	Introduction	146
11.4.2	Temporary containment measures and emergency materials and equipment	147
12	Repair and upgrading of existing containment facilities	150
12.1	Introduction	150
12.2	General maintenance and repair of concrete bund walls	150
12.2.1	Defects	150
12.2.2	Repair techniques	153
12.2.3	Surface protection	155
12.3	General maintenance and repair of earth banked containment basins, earth bunds and earth floors	156
12.3.1	Defects	156
12.3.2	Repair techniques	156
12.4	Modifications to existing bund walls	157
12.5	Drainage and transfer systems	157
12.6	Joints	158
12.7	Pipe penetrations	159
12.7.1	Introduction	159
12.7.2	Straight through	160
12.7.3	Sleeved	161
12.8	Warehouses	161
	References	163
	Statutes	168
	Useful websites	171
	Appendices	173
A1	Summary of UK and European legislation and international guidance relevant to containment	174
A2	List of hazardous substances	182
A3	Undertank leak detection systems	184
A4	Surface protection systems for concrete	186
A5	Expansion and contraction joints	188
A6	Typical details for an <i>in situ</i> reinforced concrete wall	189
A7	Typical detail for a reinforced blockwork/brickwork wall	191
A8	Typical details for earthwork lagoons and bunds	192
A9	Hydraulic pipe design	193
A10	Concrete repair techniques	194
	Boxes	
Box 1.1	Description of containment levels	2
Box 1.2	Definition of a water discharge activity	7

Box 1.2	Examples of directors imprisoned for waste management offences	4
Box 1.3	Definition of a groundwater activity	8
Box 2.3	Suggested combinations of hazard ratings to give overall site hazard rating	25
Box 2.5	Overall site risk rating as defined by combining ratings of site hazard and probability of containment failure	27
Box 3.1	Combined containment systems	33
Box 4.1	Various methods for determining the total volume of water used to fight a fire	50
Box 4.2	What to ask the Fire and Rescue Services	52
Box 4.3	Fire duration	52
Box 4.5	Summary of research on overtopping of bunds	53
Box 5.1	Summary of high level framework for process safety management	60
Box 5.1	Summary of high level framework for process safety management	60
Box 5.2	Suggested inspection and maintenance regime based on advice contained in environmental guidelines for petroleum distribution installations	60
Box 5.3	Suggested scope of baseline asset survey	62
Box 5.4	History of reinforced concrete design codes	70
Box 5.5	Reinforced concrete and liquid retaining codes	71
Box 6.1	Method for calculating bund geometry to prevent jetting	86
Box 6.2	Leakage detection guidance	88
Box 6.3	Impermeability test calculation	90
Box 6.4	Hydrodynamic forces	91
Box 6.5	Calculation of hydrodynamic loads on bund walls	92
Box A2.1	WFD priority substances	182
Box A2.2	Indicative list of the main pollutants	183
Box A2.3	Broad classes of materials with the potential to pollute water	183

Case studies

Case study 3.1	Example of process resulting in selection of remote secondary containment, West Yorkshire, UK	34
Case study 3.1	Example of process resulting in selection of remote secondary containment, West Yorkshire, UK	34
Case study 4.1	Example of managing potential effects of overtopping, Plymouth, UK	54
Case study 5.1	Example of inadequate secondary containment and drainage, Huddersfield UK	65
Case study 5.2	A baseline study: compliance and options assessment – bulk fuel tanks and bunds, UK	78
Case study 10.1	Example of the use of a pollution control valve, Shropshire, UK	136
Case study 12.1	Adaption of an existing warehouse, UK	162

Figures

Figure 2.1	A framework for environmental management	12
Figure 2.2	Source–pathway–receptor model	13
Figure 2.3	Concept of the source–pathway–receptor model	13
Figure 2.4	Relationship between risk, environmental impact and frequency	14
Figure 2.5	Risk assessment framework	15
Figure 2.6	Relationship between material quantities, toxicity and hazard	17
Figure 2.7	Establishment risk threshold frequencies (per receptor)	28
Figure 2.8	Containment system classification	30
Figure 3.1	Typical storage of IBCs in a warehouse	32
Figure 4.1	Definition of tank capacities	43
Figure 4.2	Average rainfall depths	45
Figure 4.3	Process for estimating containment capacity	56
Figure 5.1	Assessing and classifying existing structures	59
Figure 5.2	Arrow shows leaking crack in a bund wall	63
Figure 5.3	Spalling of concrete over corroding reinforced bar, where cover is reduced by groove feature	63
Figure 5.4	Rust staining that may indicate corroding reinforcement	63
Figure 5.5	Slumping of earth embankment	64

Figure 5.6	Interpretation of the 110% capacity rule	64
Figure 5.7	CCTV survey equipment and of a defect in a pipe	67
Figure 5.8	Investigation of a wall joint	67
Figure 5.9	A cover meter survey	68
Figure 5.10	A metal waterstop in a wall joint.	69
Figure 6.1	A bunded tank farm	80
Figure 6.2	Collar bunds	81
Figure 6.3	A compartmentalised bund	85
Figure 6.4	Example of installation vulnerable to jetting of fuels over the bund wall	87
Figure 6.5	Bund overflow arrangements to inhibit spread of fire.	89
Figure 7.1	Stainless steel waterstop joint detail.	98
Figure 7.2	Example of a puddle flange penetration	99
Figure 7.3	Example wall penetration	100
Figure 7.4	A 'leave in place' flanged tie bar.	101
Figure 7.5	Waterstop tied into reinforcement cage at the kicker and rear face waterstops at the planned slab joints.	102
Figure 7.6	Plastic shrinkage cracks	103
Figure 7.7	Composite masonry and concrete wall construction	104
Figure 8.1	Large earth embankment bund (in service)	107
Figure 8.2	Earth banked lagoons for 'local' containment	107
Figure 8.3	Earth banked lagoons for 'remote' containment	108
Figure 8.4	Classification of lagoons	110
Figure 8.5	Typical arrangements for protecting and anchoring a membrane liner	118
Figure 8.6	Typical arrangements for anchoring liner to concrete bund wall	119
Figure 8.7	Detail for earth bund wall penetration	119
Figure 8.8	Arrangement for sealing pipe penetrating a geomembrane liner	120
Figure 9.1	Typical arrangements for above ground tank systems.	122
Figure 9.2	A pressed steel sectional rectangular tank.	125
Figure 9.4	A precast concrete segmental tank construction (vertically multi-straked tank)	127
Figure 9.5	Use of multiple deep shaft tanks to provide containment adjacent to the source	130
Figure 11.1	Section through a typical surface area using sacrificial media for containment.	145
Figure 11.2	Section through barrier wall containment system	145
Figure 11.3	Sacrificial car park area showing temporary bunds and drain seals.	147
Figure 12.1	Common deterioration processes that affect concrete and reinforced concrete structures	153
Figure 12.2	Tying into existing earthworks.	157
Figure 12.3	Wall plate joint detail	158
Figure 12.4	Typical bund penetrations.	159
Figure 12.5	Steel split fire protection plate	160
Figure 12.6	Sealed sleeve upgrade option	160
Figure A3.1	Concrete ringwall with undertank leak detection at the tank perimeter	184
Figure A3.2	Crushed stone ringwall with undertank leak detection at the tank perimeter.	184
Figure A3.3	Earthen foundation with undertank leak detection at the tank perimeter.	184
Figure A3.4	Reinforced concrete slab with undertank leak detection at the perimeter	185
Figure A3.5	Reinforced concrete slab with radial grooves for leak detection.	185
Figure A4.1	Common deterioration processes that affect concrete and reinforced concrete structures	186
Figure A5.1	Typical details for expansion and contraction joints for the walls and bases of <i>in situ</i> reinforced concrete walls and bases	188
Figure A6.1	Typical arrangement of joints	189
Figure A6.2	Typical <i>in situ</i> reinforced concrete wall detail	190
Figure A7.1	Typical detail for a reinforced blockwork/brickwork wall	191
Figure A8.1	Foundation detail for <i>in situ</i> reinforced concrete or blockwork/brickwork bund wall with earth floor	192
Figure A8.2	Typical earthwork or lagoon bund wall detail for liner anchorage and protection details and pipe penetration details).	192

Figure A9.1	Discharge capacities of drains conveying water running full	193
Figure A10.1	Concrete repair using resin injection	194
Figure A10.2	Patch repair to concrete	194
Figure A10.3	Thin surface bonded repair to concrete.	195
Figure A10.4	Thin surface bonded repair to concrete.	196

Tables

Table 2.1	The four components of a risk assessment	12
Table 2.2	Sources of information for environmental receptors	22
Table 2.3	Frequency of loss of containment	27
Table 3.1	System selection	34
Table 3.2	Reliability of containment systems.	36
Table 4.1	List of approaches, regulations and guidelines.	38
Table 4.2	Summary of secondary containment requirements in regulations, policies, schemes and publications	42
Table 4.3	Typical water delivery rates for hydrants, hoses and fire tenders	48
Table 4.4	Forecast of firefighting water needed to tackle major chemical plant fires	50
Table 4.5	A summary of the methods presented in ISO/TR 26368:2012	51
Table 4.6	Factors that might limit delivery rates and volumes of firefighting and cooling water.	53
Table 4.7	Surge allowance (in the absence of detailed analysis).	54
Table 4.8	Summary of retention capacity recommendations.	55
Table 5.1	Key recommendations.	79
Table 6.1	Forms of bund construction	82
Table 6.2	Summary of key design recommendations	83
Table 6.3	Freeboard allowances	85
Table 6.4	Performance criteria for bunds.	94
Table 6.5	Summary of key performance recommendations by class	95
Table 7.1	Forms of masonry wall construction (for class 1 only unless otherwise stated)	104
Table 8.1	Permeability of soils by broad category	109
Table 8.2	Lining system options	116
Table 9.1	Design standards for common forms of above ground tank construction	124
Table 9.2	Performance comparison for tanks constructed above ground	128
Table 10.1	Performance requirements for transfer system components	135
Table 10.2	Summary of common forms of catchment area construction	137
Table 10.3	Pipework materials, properties and application	140
Table 10.4	Chemical resistance of pipework materials.	142
Table 10.5	Performance comparison for pipework materials.	143
Table 12.1	Possible reasons for using surface protection on cementitious surfaces	152
Table 12.1	Upgrade options for joints.	159
Table A1.1	UK and European legislation relevant to containment.	175
Table A1.2	International guidance and publications relevant to containment	178
Table A4.1	Principles and methods for protection and repair of concrete structures	186

Glossary

Absorption	A process in which one substance, usually a liquid or gas, permeates into, or is dissolved by, a liquid or solid.
Acid	A chemical substance that, in an aqueous solution, undergoes dissociation with the formation of hydrogen ions. An acidic solution has a pH below 7.0.
Alkali	A chemical substance that, in an aqueous solution, undergoes dissociation with the formation of hydroxide ions. An alkali solution has a pH of greater 7.0.
Annual exceedance probability	The probability of a flood event occurring in any year. The probability is expressed as a percentage. For example, a large flood, which may be calculated to have a one per cent chance to occur in any one year, is described as one per cent AEP.
Aquiclude	A saturated geologic unit that is incapable of transmitting significant quantities of water under ordinary hydraulic gradients.
As low as reasonably practicable (ALARP)	In the UK, a process of weighing a health, safety or environmental risk against the trouble, time and money needed to control the risk. It describes the level to which risks should be controlled. Practically, it calls for the same set of tests to be applied as with SFAIRP, however, the terms are not always interchangeable because of how the terms are cited in the relevant legislation (based on HSE ALARP 'at a glance', see <i>Useful websites</i> section).
Baseline survey	A study that looks at the characteristics of the subject at a particular time or under a particular set of conditions to establish a 'baseline'.
Benchmarking	Evaluate (something) by comparison with a standard.
Bioaccumulation	Accumulation of substances, such as pesticides, or other organic chemicals in an organism. Bioaccumulation occurs when an organism absorbs a toxic substance at a rate greater than that at which the substance is lost.
Biodegradation	The chemical dissolution of materials by bacteria or other biological means.
Biomagnification	The increase in concentration of a substance that occurs in a food chain as a consequence of persistence (cannot be broken down by environmental processes), accumulation through the food chain or the low (or non-existent) rate of internal degradation/excretion of the substance.
Biochemical oxygen demand	The amount of dissolved oxygen needed by aerobic biological organisms in a body of water to break down organic material present in a given water sample at certain temperature over a specific time period.
Borehole	The generalised term for any narrow shaft bored in the ground, either vertically or horizontally.
Bund	A facility (including walls and a base) built around an area where potentially polluting materials are handled, processed or stored. This is for the purposes of containing any unintended escape of material from that area until such time as remedial action can be taken. Bunds are usually structurally independent from the primary containment tank.
Characteristic value	Soil properties vary spatially. In the absence of a detailed soils investigation EC7 adopts the concept of a characteristic value, ie "a cautious estimate of the value", which is used for geotechnical design.
Combined sewer	A sewer that accepts both foul and surface water drainage.

Combustible	A substance that ignites and burns readily.
Competent authority	Body or bodies responsible for enforcing health, safety and environmental legislation.
Competent person/ personnel	A person who is appropriately qualified, trained and experienced for the task involved. They should also be authorised to undertake the task, for example, issued with the necessary permit to work.
Construction joints (in concrete)	A joint in concrete construction formed when placement of the concrete is interrupted for some reason. It may be the end of a day's work, or it may be that some other work needs to be completed before resuming the placement. Results in a 'surface' between freshly placed and (partly) cured concrete.
Contraction or shrinkage joints (in concrete)	Allows only for contraction or shrinkage of a slab or wall, as can be anticipated during the curing process.
Cost-benefit analysis	A defined methodology for valuing costs and benefits that enables consistent and transparent comparisons to be made between risk reduction measures to support the decision making process.
Cover-meter survey	A survey to locate reinforcement in a concrete structure and measure the depth to the reinforcement from the concrete surface.
Crack control joints	A partially-formed contraction joint, which aims to ensure that when the concrete does crack, it cracks in a predictable manner at a precise location.
Daywork joints	See <i>Construction joints</i> .
De-bonded dowels	Sleeved dowel bars placed in a movement joint to permit movement with adjacent bay without inducing stress in the structure.
Desiccation	The state of extreme dryness, or the process of extreme drying.
Design life	The time period over which a product or structure is expected to be in service and continue to function effectively.
Differential settlement	The unequal settling of a building or structures foundation (normally due to uneven settlement of the ground).
Dowelled joint	Dowels placed across a joint. A movement to permit loads to be transferred across the joint and prevent differential settlement of adjacent slabs.
Duty holder	Persons with specific duties under a specific set of regulations.
Ecotoxicological	The effects of toxic chemicals on biological organisms.
Effluent	Liquid waste or sewage.
Emulsify	The mixing of two or more liquids that are normally immiscible (non-mixable or un-blendable).
Evaporation	Vaporisation of a liquid that occurs from the surface of a liquid into a gaseous phase.
Evapotranspiration	The sum of evaporation and plant transpiration to the atmosphere.
Event effluent	The combination of inventory and any firefighting water and/or foam and rainwater arising from an event.
Expansion joints (in concrete)	Allow expansion and contraction of a concrete slab or wall without generating potentially damaging forces within the slab itself or the surrounding structures. Expansion joints are usually a complete 'gap' between adjacent bays, ie there is a definite break in the concrete and any reinforcing steel that may be present. Where adjacent bays are 'tied' together by means of dowel bars, these dowels are sleeved in one of the bays to allow expansion to take place without generating stresses within the slab.

Fire resistance	Intrinsic properties or added protection to resist the effects of fire (usually open flames, rather than high temperature alone).
Firefighting water	Water used to cool, extinguish or prevent the spread of fire during an incident. It is likely to become contaminated with product and firefighting foam as a consequence of its use in firefighting activities. Water that is used solely to cool storage tanks water sprays or deluge systems (often described as cooling water) is less likely to become contaminated with product.
Firefighting agents	Includes water-based firefighting agents such as foam. These agents are used to form an aqueous film over the inventory to prevent the escape of flammable vapours with the foam layer excluding oxygen and provides a cooling effect.
Flammable	A combustible substance (solid, liquid, gas or vapour), which is easily ignited in air. The term non-flammable refers to substances that are not easily ignited but does not necessarily indicate that they are non-combustible.
Foul drainage	Drainage system that conveys domestic sewerage.
Freeboard	An allowance in the form of increased height of a containment wall for additional capacity over and above the minimum design requirement.
Gap analysis	Determining and documenting the variance between a particular standard or requirement and the current status (see <i>Benchmarking</i> and <i>Baseline survey</i>).
Geomembrane	Typically a plastic sheet, designed for use in civil engineering/construction to prevent the movement of water or other fluids.
Geotextile	A thin sheet designed for use in civil engineering/construction to add strength or cohesion and/or maintain separation within constructed earthworks.
Good practice	In the context of this guidance the generic term for those standards for controlling risk which have been judged and recognised as satisfying the law.
Groundwater	The water beneath the earth's surface contained in soil pore spaces and in the fractures of rock formations.
Groundwater body	The principal reporting units for distinct volumes of groundwater within an aquifer or aquifers defined by the Water Framework Directive.
Gullies	In the context of this guidance a small chamber used to collecting runoff from a drained surface.
Hardstanding	Ground surfaced with a hard material for parking vehicles or storing materials.
Health and Safety Executive	UK government sponsored body responsible for implementing health and safety legislation at most installations subject to the requirements of this guidance.
Heave	Swelling of the sub-soils due to removal of overburden, increases in the water content of the soil or due to frost action.
Hydromorphology	The physical character of rivers shaped by the movement of water through the catchment.
Hypochlorite	An ion composed of chlorine and oxygen. Their primary applications are as bleaching, disinfection and water treatment agents but are also used for chlorination and oxidation reactions.
Ignition protected	An electrical component that is capable of operating in an explosive environment without igniting that environment.
Immiscible	Not capable of being mixed.
Interceptor	A device installed normally in a surface water drainage system to remove hydrocarbons and fats, and from runoff.

Inventory	In the context of this guide a generic term to describe the contents of the primary containment substances that may be flammable or hazardous to the environment.
ISO tanks	An ISO tank (or tank container) is a pressure vessel held within a 20-foot ISO frame that is used for the transportation and storage of bulk liquids. The 20-foot ISO frame ensures that tank containers can be transported using most modern inter-modal transportation options, including container ships, trucks and rail. A tank container built to the ISO standard making it suitable for different modes of transportation.
Kerb	Edge where a raised pavement meets an un-raised street or other roadway.
Kicker joints	A small upstand cast as part of a concrete base to allow the securing of wall shutters.
Lagoon	An excavated area able to retain liquids as a consequence of the excavated area being below the level of the surrounding area, rather than being retained within a raised area.
Leaching	The removal of soluble or other constituents from a substance by the action of a percolating liquid.
Limpet dam	A dam that affixes to a surface.
Liner	A designed, additional layer or layers that provide separation and liquid impermeability to a bunded area or structure.
Local containment	A form of secondary or tertiary containment designed to contain locally to the source, product or firewater from a loss of containment, eg a bund.
Major accident to the environment	Harm or damage to the environment above defined thresholds.
Maximum capacity	The maximum volume of liquid a storage tank can hold without loss of containment (from overflow or overflow), or damage to the tank structure (due to collision between an internal floating roof and other structures within the tank, or for some fluids, overstressing due to hydrostatic loading). This capacity is greater than the normal capacity and tank-rated capacity.
Multi-straked tanks	Tanks formed with precast or prestressed reinforced concrete wall panels restrained with an external hoop (post-tensioned). This is a common form of construction used to create slurry stores and filter beds at wastewater treatment works.
Non-destructive testing	Testing that does not require the destruction of the material/structure being tested (as opposed to destructive testing that does).
Normal capacity	Level to which a storage tank should be intentionally filled under routine process control. See <i>Maximum capacity</i> and <i>Tank-rated capacity</i> .
Organic compounds	Any member of a large class of gaseous, liquid, or solid chemical compounds whose molecules contain carbon.
Organochlorine solvents	An organic compound containing chlorine. Many derivatives are controversial because of the effects of these compounds on the environment and on human and animal health.
Overflow level	See <i>Maximum capacity</i> .
Overtopping	Flow of liquid over a structure within its path.
Penetration	Pipe or other duct or structure that passes through the wall or floor of a bunded or lined area.
Intumescent	A substance that swells as a result of heat exposure, increasing in volume and decreasing in density. Intumescent are typically used in passive fire protection.

Permeability	Measure of the movement of a fluid (liquid or gas) through a solid material applied to barriers (such as liners or bund walls) or bulk solids (such as soil). Typically measured in metres per second.
Pesticides	Substances used for preventing, destroying or mitigating any pest. They are a class of biocide, a chemical substance or microorganism that can deter, render harmless, or exert a controlling effect on any harmful organism by chemical or biological means.
pH	A measure of the acidity or alkalinity of a solution, numerically equal to 7 for neutral solutions, increasing with increasing alkalinity and decreasing with increasing acidity.
Photolysis	Chemical reaction in which a chemical compound is broken down by photons (light).
Primary containment	The most important means of preventing major incidents involving loss of inventory. It is achieved by the equipment that has direct contact with the inventory stored or transferred such as storage tanks, IBCs, drums, pipework, valves, pumps and associated management and control systems. It also includes equipment that prevents the loss of primary containment under abnormal conditions, such as high-level alarms linked to shut down systems.
Reinforcement	Commonly steel rods incorporated into concrete structures to enable them to withstand tensile and shear forces.
Remote containment	Form of secondary or tertiary containment that is distant from the area of the primary containment.
Risk	Product of likelihood and consequences of environmental impact, adverse human health, business interruption etc from a hazard. Also, may refer to a stated period of time.
Risk assessment	Process to determine the level of risk posed by a hazard.
Runoff	Movement of liquid over the surface of land in accordance with the topography.
Secondary containment	Minimises the consequences of a failure of the primary storage by preventing the uncontrolled spread of the inventory. Secondary containment is achieved by equipment that is external to and structurally independent of the primary storage, for example concrete or earth bunds around storage tanks, or the walls of a warehouse storing drums. Secondary containment may also provide storage capacity for firefighting and cooling water.
Settlement	Consolidation of a soil that results in a decrease in soil volume.
Sewage effluent	Liquid sewerage.
Slumping	A segment of a cliff, slope or embankment moving down-slope along a saturated shear-plane.
So far as is reasonably practicable (SFAIRP)	In the UK, a process of weighing a health, safety or environmental risk against the trouble, time and money needed to control the risk. It describes the level to which risks should be controlled. Practically, it calls for the same set of tests to be applied as with ALARP, however, the terms are not always interchangeable because of how they are cited in the relevant legislation.
Soakaway	A chamber or other below ground structure that aids the infiltration of runoff into the ground.
Source-pathway-receptor assessment	Risk assessment methodology where impacts to the environment are assessed on whether there is a source (eg a released product), a receptor (eg groundwater), and a pathway (eg a drain leading to a river) by which the source material could reach the receptor. See <i>Risk assessment</i> .

palling	The process of surface failure in which spall (flakes of a material that are broken off a larger solid body by a variety of mechanisms including corrosion and weathering) is shed.
Strake/straked tank	A section of a cylindrical tank. In a straked tank, strakes may be joined by welding or sealed to adjacent strakes with or without additional circumferential tension hoops.
Shell	The cylindrical section of the tank or vessel formed by 1 or more 'strakes'
Stormwater drainage	Drainage system that conveys runoff resulting from rainfall.
Subsidence	The motion of a surface as it moves downward relative to a datum.
Tank rated capacity	Theoretical fill level in a storage tank that is far enough below the maximum capacity to allow time to respond to final warning alarms and still prevent loss of containment.
Tertiary containment	Minimises the consequences of a failure in the primary and secondary containment systems. This is done by providing an additional level of protection preventing the uncontrolled spread of the inventory such as site drainage and sumps, diversion tanks and lagoons, containment kerbing to roadways and parking areas and impervious liners and/or flexible booms. Tertiary containment will be used when there is an event that causes the escape of liquids from the secondary containment through failure or overflow (eg bund joint failure, or firewater overflowing from a bund or escaping from building/warehouse during a prolonged fire).
Trade effluent	Any liquid waste, other than surface water and domestic sewage that is discharged from premises being used for a business, trade or industry.
Underdrains	An underground drain or trench with openings through which the water may percolate from the soil or ground above.
Waterbars	Preformed strip of durable impermeable material that is wholly or partially embedded in concrete bund walls and floors during construction or remediation. The strip is located across joints in the structure to provide a permanent liquid-tight seal during the whole range of joint movements.
Waterstops	See <i>Waterbars</i> .

Abbreviations and acronyms

ALARP	As low as reasonably practicable
AMN	All measures necessary
BAT	Best available techniques
BOD	Biochemical oxygen demand
CA	Competent Authority
CBA	Cost-benefit analysis
FMEA	Failure, mode and effect analysis
FTA	Fault tree analysis
FWMA	Flood and Water Management Act 2010
GHS	Globally harmonised system
HAZOP	Hazard and operability studies
HSE	Health and Safety Executive
IBCs	Intermediate bulk containers
MATTE	Major accident to the environment
NGOs	Non-government organisations
PPG(s)	Pollution prevention guidelines
QSRMC	Quality Scheme for Ready Mix Concrete
SDS	Safety data sheet
SFAIRP	So far as is reasonably practicable
TifALARP	Tolerable if as low as reasonably practicable
WFD	Water Framework Directive
WwTW	Wastewater treatment works

1 Introduction

This chapter provides:

- An introduction to this guide, its scope, and the issues excluded from the scope (Sections 1.1 and 1.2)
- The regulatory context for the guidance (Sections 1.3 and 1.4)
- A number of other drivers for producing the guidance (Section 1.5)
- A brief summary of key regulations and existing guidance (Section 1.6)
- Information on risk assessments (Section 1.7)

1.1 OBJECTIVES

This guidance has been developed to assist owners and operators of industrial and commercial facilities to identify and manage the risks associated with storing substances that may be flammable/combustible or hazardous to the environment. Throughout the remainder of this guidance these are referred to as 'inventory' for brevity.

It is applicable to the containment of a wide range of inventories with the potential to pollute land and water and to all sizes of site from small commercial premises, which may contain a single tank, through to large chemical or petrochemical sites. Experience has shown that many incidents occur in warehouses and other storage facilities, which are also covered here.

It advocates a risk-based approach to managing the storage of inventory. However, it is important to ensure that the risk assessment methodology used is appropriate to the regulatory regime within which a site or facility is operating and there will be instances where there are statutory requirements for containment, which must be complied with irrespective of the risk (eg The Control of Pollution (Oil Storage) (England) Regulations (OSR) 2001).

Guidance is also provided on the inspection, maintenance, repair, extension or, in cases of change of use, upgrading of existing containment systems.

The guidance deals principally with managing the potential consequences of a failure of the storage tank or vessel (the primary containment) and/or the combustion of its contents. **Secondary** containment is provided to prevent:

- the inventory,
- firefighting agents, and
- rainfall runoff that has come into contact with the inventory

reaching the wider environment.

As will be discussed in Chapter 4, where flammable inventory is stored, it is often impractical to provide sufficient secondary containment local to the primary containment to cater for the firefighting and cooling water that might be applied during an incident. **Tertiary** containment provides a further level of protection should the secondary containment be overwhelmed by firefighting and cooling water, or fail.

Primary, secondary and tertiary containment are more fully described in Box 1.1.

Primary containment or storage is the most important means of preventing major incidents involving loss of inventory. It is achieved by the equipment used to store or transfer it such as storage tanks, intermediate bulk containers (IBCs), drums, pipework, valves, pumps and associated management and control systems. It also includes equipment that prevents the loss of primary containment under abnormal conditions, such as high-level alarms linked to shut-down systems. While this guide does not cover primary storage, a summary of other documents providing this is given in Chapter 9.

Secondary containment minimises the consequences of a failure of the primary storage by preventing the uncontrolled spread of the inventory. Secondary containment is achieved by equipment that is external to and structurally independent of the primary storage, for example concrete or earth bunds around storage tanks, or the walls of a warehouse storing drums. Secondary containment may also provide storage capacity for firefighting and cooling water. The options for providing secondary containment are discussed in Part 3 of this guidance.

Tertiary containment minimises the consequences of a failure in the primary and secondary containment systems by providing an additional level of protection preventing the uncontrolled spread of the inventory. These include purpose built structures such as diversion tanks and lagoons, but can also use other measures such as containment kerbing to roadways and parking areas and impervious liners and/or flexible booms. Tertiary containment will be used when there is an event that causes the escape of liquids from the secondary containment through failure or overflow (eg bund joint failure, or firewater overflowing from a bund or escaping from building/warehouse during a prolonged fire).

1.2 EXCLUSIONS

The following issues are not covered in this guide:

Issue	Commentary
Primary containment	<ul style="list-style-type: none"> ■ details of the management and maintenance of primary containment systems (although the need for good management practices and the role of protective and warning devices to prevent or detect spillages is included) ■ good practice guidance for the design, manufacture, installation, operation, inspection and maintenance of chemical storage tank systems can be found in Cassie and Seale (2003).
Types of installation	<ul style="list-style-type: none"> ■ underground storage tanks ■ buried/mounded tank/vessels ■ off-shore installations.
Off-site activities	<ul style="list-style-type: none"> ■ the transportation of materials off site by road, rail, sea or air ■ spills from pipelines between industrial premises.
Stored inventory	<ul style="list-style-type: none"> ■ above ground tanks/vessels for the storage of liquid petroleum gas (LPG), and liquefied natural gas(LNG) and other cryogenic substances etc ■ above ground tanks/vessels for the storage of natural gas ■ radioactive substances, hazardous biological organisms or chemicals used in small quantities such as in research laboratories ■ sewage and sewage effluents, farm wastes and related materials.
Source/cause of pollution	<ul style="list-style-type: none"> ■ gradual or continuing pollution, eg leaching from contaminated land ■ abandoned sites ■ pollution as a consequence of atmospheric emissions.
Post-incident clean-up	<ul style="list-style-type: none"> ■ the recovery, recycling or disposal of contaminated chemicals, wash waters, effluents, contaminated fire waters etc (unless this affects the containment system design/selection) ■ monitoring, clean-up or treatment after the occurrence of an incident.

1.3 REGULATORY CONTEXT

1.3.1 Range of sites

This guidance reflects current good practice for the design and maintenance of containment systems for the prevention of pollution. It is intended for use by site managers, design engineers, contractors, regulators and others. Following these guidelines will help businesses manage their environmental responsibilities to prevent pollution and comply with the law.

The guide covers a range of commercial and industry sectors. While most of the principles of this guide can be applied across these sectors, each sector will operate under a specific set of regulatory regimes (see Section 1.5 – some being risk-based and others setting absolute requirements. It is recognised that this guide will be used in a wide variety of applications, which include the hundreds of sites falling under the Control of Major Accident Hazards Regulations (COMAH) 1999, the thousands of sites falling under the Environmental Permitting (England and Wales) Regulations (EPR) 2010 and related regulatory regimes and the tens of thousands of other sites that exist across the UK. The guide does not specify regulatory practice such as the approach to inspection and/or the focus on particular sectors or sites.

Where current policies and guidance are already in place, and are either more or less onerous or differ from the guidance provided here, this publication should be seen as providing supplementary information, rather than additional requirements, on design, inspection and maintenance of containment measures.

1.3.2 Risk

A key feature of this guide is a risk assessment framework and a three-tier classification system, referred to as **classes**, upon which different standards of containment construction or levels of performance are required in accordance with the three levels of risk. This three-tier approach has been applied on many COMAH, EPR and equivalent regulated sites and other unregulated sites. It is acknowledged that other approaches are available and can be used, however the operator should be able to demonstrate an equivalent approach to that set out here.

1.3.3 Existing sites

The guide provides owners and operators of existing sites with ways of identifying and mitigating any pollution risk inherent in their installations and how the adequacy of any newly acquired site may be assessed. Any gaps between the recommendations presented here (or other specific codes etc agreed between regulators and industry) and the situation at a specific site should be dealt with in a manner that satisfies the relevant legal requirements (including risk and cost-benefit factors in deciding whether to upgrade).

The application of this guidance to existing facilities should be based on risk, and any upgrades completed to reduce risk sufficiently to satisfy the law and to be in accordance with guidance under the relevant legislative regime. Upgrades may be subject to as low as reasonably practicable (ALARP) and/or best available techniques (BAT) 'tests' and supporting cost-benefit analyses (CBA) depending on the legislative regime (COMAH, EPR etc). It is, however, recognised that the costs of upgrading existing facilities might outweigh the environmental benefits, and therefore not be viable, or that other equally effective risk reduction measures to those suggested in this guidance may be implemented. Guidance on how to make such decisions is available for differing legislative regimes and can also be clarified by discussion with the regulators.

With the exception of sites where changes in use or extensions are proposed, existing requirements in terms of frequency of inspections, risk assessment updates stipulated by current regulations (or agreed in previous industry regulator negotiations) are not expected to change. However, existing sites may need to improve their records and their inspection and risk assessments if they are not currently adopting good practice. It is not anticipated that regulators will significantly alter their inspection strategies as a direct result of this revision, however the guide will be referred to as providing good practice and may influence the content of future inspection campaigns.

1.4 OTHER DRIVERS

The earlier section *Why read this guide* introduced a number of drivers for ensuring good practice and the consequences on the organisation, which include:

- penalties, liabilities and reputational issues

- corporate governance
- corporate social responsibility (CSR).

These are each considered briefly in Sections 1.4.1 to 1.4.3.

1.4.1 Penalties, liabilities and reputation issues

Ineffective containment of pollutants can result not only in environmental harm but can also have a severe effect on the company concerned. In the past, fines imposed for pollution offences were trivial compared with the cost of installing protective measures. However fines have been increased significantly and in July 2010 five companies were fined a total of £9.5m for their part in the Buncefield catastrophe, a disaster that it is estimated had a total cost exceeding £1 billion.

Environmental legislation also empowers courts to imprison directors and managers of companies if pollution is proved to have resulted from their negligence. Several cases of imprisonment have been imposed for waste management offences (see Box 1.2) and this trend may spread into other areas of environmental management.

Box 1.2 *Examples of directors imprisoned for waste management offences*

Prison sentences handed out for leakage and dangerous storage of composting leachate, February 2014

Three directors of a South Wales company prosecuted – one received a 12 month prison sentence, 250 hours of unpaid work, five year ban from being a director; another received 32 week imprisonment, 150 hours unpaid work and three year ban director ban. The third received a 16 week prison sentence and a two year director ban. A financial investigation is under way. Clean up costs estimated at £1.6m so the company are likely to get a very large fine. In the past it had received a £35 000 fine for breaching permit conditions.

For more information go to:
<http://resource.co/business/article/wormtech-directors-sentenced-jail>
http://resource.co/article/Waste_Law/WormTech_closes_following_environment_permit_loss-2350

Custodial sentence and £330 000 penalty for illegal wood waste operations, January 2014

The company owner was sentenced at Sheffield Crown Court (7 January) over four charges relating to the operation of illegal wood waste facilities in Mansfield and Sheffield without an environmental permit.

The 49 year old was given a nine month custodial sentence, ordered to pay £250 000 in confiscation under the Proceeds of Crime Act 2002, ordered to pay £80 000 in investigation and costs, along with a £120 victim surcharge.

For more information go to: www.ciwm-journal.co.uk/archives/5596

Websites accessed 29 May 2014

In addition to prosecution for criminal acts, there is an increasing trend for companies, individuals and the statutory authorities to use civil proceedings for the recovery of costs incurred in cleaning up after pollution incidents. These costs can be extremely high, particularly in cases where the clean-up of contaminated land or groundwater is involved.

It is difficult to assess all the liabilities and resulting financial implications arising from the contamination caused by loss of containment. The widely reported case of Cambridge Water Company versus Eastern Counties Leather (BAILII, 1993) in which spillages of a chlorinated solvent migrated into an aquifer, and then to a borehole used for potable water supply, had a profound effect on the insurance industry.

Given the uncertainties, it may be difficult, or perhaps impossible to obtain insurance cover for all the potential liabilities, in particular for fines and authority investigation costs. Provisional statistics compiled by the HSE indicate that the average fine per conviction resulting from enforcement actions over the 2012/2013 fiscal year was circa £29 000 for the manufacturing sector. Insurance premiums are likely to rise for companies that cause major or highly publicised incidents. One way that companies can protect themselves against future liabilities is by providing high integrity containment systems for materials known to endanger the environment. The rate of increase in premiums may be lower for those with good facilities and management systems.

1.4.2 Corporate governance

Corporate governance demands that asset owners are aware of the value of their portfolio, including future maintenance liabilities and risks to operation. This is clearly applicable to the containment systems covered in this guidance.

Hooper *et al* (2009) provide advice on asset management.

1.4.3 Corporate social responsibility

While companies regard legal compliance as a major priority, leading organisations are acutely aware of their reputational image and are becoming more open to the publication of information relating to their environmental performance.

Corporate responsibility or corporate social responsibility (CSR) has become a part of business risk management. Historically, businesses have had to address some of their key risks such as their health, safety and environmental issues through legislative drivers. Failure to comply results in fines and poor press coverage can have a direct impact on the financial performance and future of the business.

Increasingly, poor performance in these areas has been deemed unacceptable and most organisations now recognise the financial, reputational and business continuity risks of not being in control of their health, safety and environmental activities. This has resulted in businesses taking greater responsibility in identifying, managing and mitigating their health, safety and environmental risks. They now are reporting regularly to risk management committees, audit committees and their company Board and presenting key data in annual financial reports and accounts for shareholder evaluation.

As the business environment has evolved, so have the risk profiles, challenges and pressures faced by business. Stakeholders in particular (including investors, staff, non-government organisations (NGOs), local communities, suppliers, the media and customers) are demanding good corporate conduct that includes but also extends beyond health, safety and environmental compliance to address other business impacts such as social and ethical matters. Corporate responsibility has arisen from the pressure for business to be responsible and to be held accountable for its wider impacts such as:

- pollution prevention
- supply chain
- human rights
- bribery and corruption
- biodiversity
- workplace diversity
- ethics.

1.5 UK AND EU LEGISLATION, INTERNATIONAL GUIDANCE AND PUBLICATIONS RELEVANT TO CONTAINMENT

1.5.1 Introduction

Details of the legislative framework and guidance relevant to containment within the UK are presented in Appendix A1 (see Tables A1.1 and Table A1.2).

In the UK various government agencies enforce UK regulations relevant to containment and pollution prevention, these include:

- Environment Agency (EA) for England
- Natural Resources Wales/Cyfoeth Naturiol Cymru (NRW) for Wales
- Environment and Heritage Service (EHS) for Northern Ireland

- Scottish Environment Protection Agency (SEPA) for Scotland
- Competent Authority (CA) for COMAH sites
- Health and Safety Executive (HSE).

Those UK organisations generally responsible for environmental regulation, ie the EA, NRW, EHS and SEPA, are collectively referred to as the ‘regulator’ throughout this guide.

In the UK business owners are responsible for checking the legal requirements that apply to their business activities. Online business advice and support, which help identify regulations that are applicable to various types of business or activities are provided on regulators'/government websites:

- For England and Wales: www.environment-agency.gov.uk/business/default.aspx
- For Northern Ireland and Scotland: www.netregs.gov.uk

In addition, there is much good advice contained in the series of pollution prevention guidelines (PPGs) published jointly by the EA, NIEA and SEPA at (see *Websites* box at the end of the chapter).

Many sites will be covered by regulations whose focus is considerably wider than water and ground pollution. This may include air pollution and risk to humans. A brief summary of the key regulations are set out below, with reference to Appendix A1 for further details.

1.5.2 Control of Major Accident Hazards Regulations (COMAH)

COMAH implement the Seveso II Directive (Council Directive 96/82/EC), except for land use planning requirements, which are implemented by changes to planning legislation. Their main aim is to prevent and mitigate the effects of those major accidents involving dangerous substances that can cause serious damage/harm to people and/or the environment. COMAH regard risks to the environment as serious as those to people.

COMAH apply mainly to the chemical and petrochemical industries. Other businesses to which they apply include those storing fuels or alcoholic spirits, having large warehouses or distribution facilities, or manufacturing and storing explosives. They apply where threshold quantities of dangerous substances identified in the regulations are kept or used. There are two thresholds known as COMAH lower tier and top tier. To determine whether these Regulations apply, it is necessary to determine if there are sufficient dangerous substances to exceed the lower threshold quantities defined in the regulations.

The regulations are enforced by a COMAH Competent Authority (CA) comprising HSE and the EA in England, HSE and NRW in Wales, and HSE and SEPA in Scotland. Operators will generally receive a single response from the CA on all matters to do with COMAH.

COMAH ensure that businesses and duty holders:

- take all measures necessary (AMN) to prevent major accidents involving dangerous substances
- limit the consequences to people and the environment of any major accidents that do occur.

AMN have to be in place so far as is reasonably practicable (SFAIRP) to prevent environmental harm and in particular a major accident to the environment (MATTE). AMN are interpreted to require use of good practice for pollution prevention and the CA considers these to be in place when the risks are demonstrated to be either ‘broadly acceptable’ or ALARP. As this is an important concept, the HSE’s definition of ALARP is repeated here verbatim:

“ALARP, ‘as low as reasonably practicable’, enables the regulator to set goals for duty-holders, rather than being prescriptive. This flexibility is a great advantage but it has its drawbacks too. Deciding whether a risk is ALARP can be challenging because it requires operators and regulators to exercise judgement. In essence, making sure a risk has been reduced ALARP is about weighing the risk against the sacrifice needed to further reduce it. The decision is weighted in favour of safety because the presumption is that the duty-holder should implement the risk reduction measure. To avoid having to make this sacrifice, the duty-holder must be

able to show that it would be grossly disproportionate to the benefits of risk reduction that would be achieved. Thus, the process is not one of balancing the costs and benefits of measures but, rather, of adopting measures except where they are ruled out because they involve grossly disproportionate sacrifices.”

The HSE provides a suite of ALARP related documents on their website (see *Websites* box).

Further guidance on the CA's position on AMN relating to prevention and mitigation of environmental aspects of major accidents can be found in HSE (2012 and on MATTE in CDOIF (2011).

Note

It is anticipated that the Seveso II Directive (Council Directive 96/82/EC) will be replaced in 2015 by the Seveso III Directive (Directive 2012/18/EU). It is understood that the major change will be the use of the globally harmonised system (GHS) for classification of chemicals to determine whether they are within the scope of the Directive. When the new Directive is implemented, there is the potential for sites to change their COMAH status (top tier, lower tier or non-COMAH), depending on the substances and quantities held.

1.5.3 EPR (England and Wales) 2010, PPC (Northern Ireland) 2003 and PPC (Scotland) 2012

The Environment Permitting Regulations (England and Wales) (EPR) 2010, the Pollution Prevention and Control Regulations (Northern Ireland) (PPC) 2003 and the Pollution Prevention and Control (Scotland) Regulations (PPC) 2012 implement Industrial Emissions Directive (IED) (Council Directive 2010/75/EU). These require installations to be operated in a way that provides a high level of protection to the environment as a whole and, in particular, soil and groundwater.

It is the primary operating environmental permit regime in use in the UK for which core guidance is given in Defra (2013).

It is an offence to discharge without authorisation, or exceed the conditions stated on an environmental permit. In particular, Schedule 38 of the EPR 2010 makes it an offence to cause or knowingly permit a 'water discharge activity' or 'groundwater activity' unless authorised by an environmental permit. Similar regulation applies in Scotland and Northern Ireland.

The definitions of a 'water discharge activity' and 'groundwater activity' are set out in Boxes 1.2 and 1.3. In Scotland the regulations are broader and, in respect of discharges, apply to activities likely to cause pollution of the water environment and any other activity that directly or indirectly has or is likely to have a significant adverse effect on the water environment.

Box 1.2 Definition of a water discharge activity (from EPR, 2010)

Schedule 21 (3)

A "water discharge activity" means any of the following—

- (a) the discharge or entry to inland freshwaters, coastal waters or relevant territorial waters of any
 - (i) poisonous, noxious or polluting matter,
 - (ii) waste matter, or
 - (iii) trade effluent or sewage effluent;
- (b) the discharge from land through a pipe into the sea outside the seaward limits of relevant territorial waters of any trade effluent or sewage effluent;
- (c) the removal from any part of the bottom, channel or bed of any inland freshwaters of a deposit accumulated by reason of any dam, weir or sluice holding back the waters, by causing it to be carried away in suspension in the waters, unless the activity is carried on in the exercise of a power conferred by or under any enactment relating to land drainage, flood prevention or navigation;
- (d) the cutting or uprooting of a substantial amount of vegetation in any inland freshwaters or so near to any such waters that it falls into them and failure to take reasonable steps to remove the vegetation from these waters;
- (e) an activity in respect of which a notice under paragraph 4 or 5 has been served and has taken effect.

Schedule 22 (3)

A “groundwater activity” means any of the following—

- (a) the discharge of a pollutant that results in the direct input of that pollutant to groundwater;
- (b) the discharge of a pollutant in circumstances that might lead to an indirect input of that pollutant to groundwater;
- (c) any other discharge that might lead to the direct or indirect input of a pollutant to groundwater;
- (d) an activity in respect of which a notice under paragraph 10 has been served and has taken effect;
- (e) an activity that might lead to a discharge mentioned in paragraph (a), (b) or (c), where that activity is carried on as part of the operation of a regulated facility of another class

A discharge or an activity that might lead to a discharge is not a “groundwater activity” if the discharge is—

- (a) made, or authorised to be made, by or under any prescribed statutory provision; or
- (b) of trade effluent or sewage effluent from a vessel.

The regulator may determine that a discharge, or an activity that might lead to a discharge, is not a groundwater activity if the input of the pollutant-

- (a) is the consequence of an accident or exceptional circumstances of natural cause that could not reasonably have been foreseen, avoided or mitigated;
- (b) is or would be of a quantity and concentration so small as to obviate any present or future danger of deterioration in the quality of the receiving groundwater; or
- (c) is or would be incapable, for technical reasons, of being prevented or limited without using—
 - (i) measures that would increase risks to human health or to the quality of the environment as a whole, or
 - (ii) disproportionately costly measures to remove quantities of pollutants from, or otherwise control their percolation in, contaminated ground or subsoil.

Note

The EPR require operators of installations to use best available technique (BAT). Where such installations covered in Schedule 1 have bulk storage of hazardous materials, guidance on what represents BAT is given in the BREF document for emission storage (European Commission, 2006).

BAT takes into account the balance between the costs and environmental benefits and in a similar manner to AMN under COMAH, are interpreted to require use of ‘good practice’ for pollution prevention. Further guidance on BAT in relation to particular industry sectors can be found on the EA’s website (see *Websites* box).

1.5.4 The Control of Pollution (Oil Storage) (England) Regulations (OSR) 2001

The Oil Storage Regulations (OSR) apply where more than 200 litres of oil is to be stored. With the exception of those situations set out in paragraph 2.(2) of the Regulations, secure containment facilities must be provided for tanks, drums, IBCs and mobile bowsers to prevent oil escaping into the environment.

It should be noted that there are differing requirements for each UK country and reference should be made to the primary legislation and to Appendix A1.

1.5.5 The European Water Framework Directive (WFD)

The European Water Framework Directive (WFD) (Directive 2000/60/EC) was transposed into UK law in December 2003 and requires that all inland (including groundwater bodies) and coastal waters achieve at least ‘good’ status. The status of a water body is essentially determined from its biological, hydromorphological and physio-chemical properties. The WFD has established river basin districts for which river basin management plans have been developed by the CA that detail the actions (a programme of measures) required to meet these objectives.

Any activities, such as new development that potentially could lead to deterioration in the status of a waterbody, or would render proposed improvement measures ineffective, would be contrary to the Directive. Details of the WFD classification assessment can be found on the EA’s website (see *Websites* box).

1.5.6 Other legislation and guidance

Flood and Water Management Act 2010

The largest of bunds/lagoons might fall in scope of reservoirs safety legislation as part of the Flood and Water Management Act (FWMA) 2010. Where a structure is currently capable of holding more than 25 000 m³ of water above the natural level of any part of the surrounding land it falls within the scope of the Act and must be registered.

The regulator interprets capacity to hold water to include any capacity intended for rainwater or firewater or other site drainage water. A chemicals bund would not therefore be in scope if the foreseeable volumes of water that could be in the bund do not exceed the threshold.

Note

Primarily reservoir safety in England, Wales and Scotland comes under the Reservoirs Act 1975. There is currently no reservoir safety legislation in Northern Ireland. This applies to any raised reservoir storing 25 000 m³ or more of water above natural ground level. The FWMA 2010 modifies sections of the Reservoirs Act in England and Wales and is likely to include measures to bring any reservoirs stored to 10 000 m³ within the scope of the Act. However at the time of writing there is currently no timetable for when this might be enacted through secondary legislation. The Reservoirs (Scotland) Act 2011 applies in Scotland and will repeal the Reservoirs Act 1975 in Scotland, when implemented (possibly 2015). This will include a volume threshold of 10 000 m³.

BASIS Registration Scheme

The BASIS Registration Scheme (see *Websites* box) has been established to develop standards for the safe storage and transport of agricultural, horticultural and forestry pesticides. Registered stores are audited annually to ensure that the store, the people who operate it and the staff who provide advice on professional pesticides meet their legal obligations and are taking all reasonable precautions to protect people and the environment.

Safety data sheets

Specific advice on the management of inventory is also available from its specific safety data sheet (SDS) (see *Websites* box). SDS should be provided by the inventory suppliers, or can be obtained from a number of readily available sources on the internet.

1.6 ASSESSING THE RISK

Fire is the most common cause of serious pollution incidents. A relatively small proportion of incidents stem directly from the catastrophic failure of tanks or vessels. On-site traffic movements and loading movements are also a regular cause of incidents involving rupture of tanks, drums, vessels, bunds or pipework. For smaller sites vandalism is of increasing concern.

A risk assessment provides a transparent and objective means of assessing the likelihood and consequences of a loss of containment based on the source–pathway–receptor model (see Chapter 2). The outcome of the assessment will aid the development of an holistic containment strategy based on the hazard posed by the inventory to be stored or moved within the site, and the sensitivity of potential receptors should a spillage occur. While this strategy may include a combination of prevention (containment) and mitigation measures, the former are considered preferable.

The starting point of any proposal to modify or extend an existing facility, or construct a new facility should be a risk assessment. The risk assessment will assist in informing the design, development of an appropriate inspection and maintenance regime or, where resources are limited, to prioritise risk reduction measures.

Risk assessments are covered in detail in Chapter 2, however, the principal role of the containment systems associated with this guidance is to break the pathway between the source, (the inventory in the primary container), and any potential receptors, eg watercourses, groundwaters, habitats.

Websites

Pollution prevention advice and guidance (PPG):

<https://www.gov.uk/government/collections/pollution-prevention-guidance-ppg>

ALARP: www.hse.gov.uk/risk/theory/alarp.htm

BAT: <http://tinyurl.com/p5ejk5q>

BASIS Registration Scheme: www.basis-reg.com/default.aspx

Safety Data Sheets (SDS):

<http://echa.europa.eu/en/regulations/reach/safety-data-sheets;jsessionid=DBF175C3E30F71B7939CE3F89E727CA5.live1>

Water Framework Directive classification (2013 update):

<https://www.gov.uk/government/publications/water-framework-directive-classification-2013-progress-update>

Accessed 29 May 2014

2 Risk assessment and classification of secondary and tertiary containment systems

This chapter provides:

- A brief introduction to environmental risk assessments (Section 2.1)
- A framework around which hazards and risks may be assessed in the context of containment design (Sections 2.2 to 2.5)
- An approach to containment design based on these ratings (Sections 2.6)

2.1 INTRODUCTION

This chapter provides a risk assessment methodology to support a three-tier risk-based classification system for secondary and tertiary containment. This classification system recommends different standards of construction, or levels of performance in accordance with each of the three levels of risk. It provides guidance on completing an assessment of the risks posed (principally to the water environment and soils) should there be a release of the inventory stored in the primary containment. The results of the assessment are then used to set standards for specifying mitigation measures appropriate to the risk.

As stated in Chapter 1, the duty holder may take a different approach to determining an appropriate level of performance and standard of construction for their facility than the one described in this chapter. However, regulators may expect the duty holder to reconcile their proposed approach with that set out in this guide.

This guidance will use the following definitions, which are consistent with European law:

- **hazard** is the intrinsic property of a dangerous substance or physical situation, with a potential for creating damage to human health and/or the environment
- **risk** is the likelihood of a specific effect occurring within a specified period or in specified circumstances.

Risk is therefore a combination of **consequence** and the **likelihood** (or probability of occurrence) of that consequence. Consequence can be further defined in terms of the **extent** of harm and the **severity** of harm. In addition to extent and severity, consequence is also a function of duration of harm (both environmental harm index (EHI) and CDOIF (2013a) benchmark this against timescale for natural recovery).

It is a requirement under health and safety and environmental legislation that a duty holder manages potential hazards to comply with the law. Discharging this responsibility generally includes a requirement to apply good practice in the management of risk.

It is unlikely to be economic to provide the primary storage such that it is 100 per cent safe, ie it can be guaranteed not to permit the escape of inventory in every conceivable circumstance. No matter how much care is taken there is always a finite risk that, for example, a particular hazard has not been recognised, structural elements or materials do not behave as predicted or an error in the design or construction was made. Additional risks and uncertainties can be introduced throughout the service life of a primary containment system if it is poorly maintained, it is put to a different use not considered by the original design, or is modified or extended in an inappropriate manner.

Generally following this guidance will assist duty holders to demonstrate that they have managed these risks to comply with the law, specifically through the provision of secondary and potentially tertiary containment.

Defra (2011) provides generic guidelines for the assessment and management of environmental risks. While the guidelines focus on generic principles, the framework presented underpins the specific risk assessment methodology set out in this guide and identifies four main components of risk assessment (see Table 2.1).

Table 2.1 The four components of a risk assessment

Task	Chapter
Formulating the problem	Chapter 2
Carrying out an assessment of the risk	
Identifying and appraising the management options available	Chapters 3 and 4
Addressing the risk with the chosen risk management strategy	Chapters 6 to 11

The guidelines emphasise that environmental risk management is not a single, one-off exercise, but a dynamic process as illustrated by Figure 2.1.

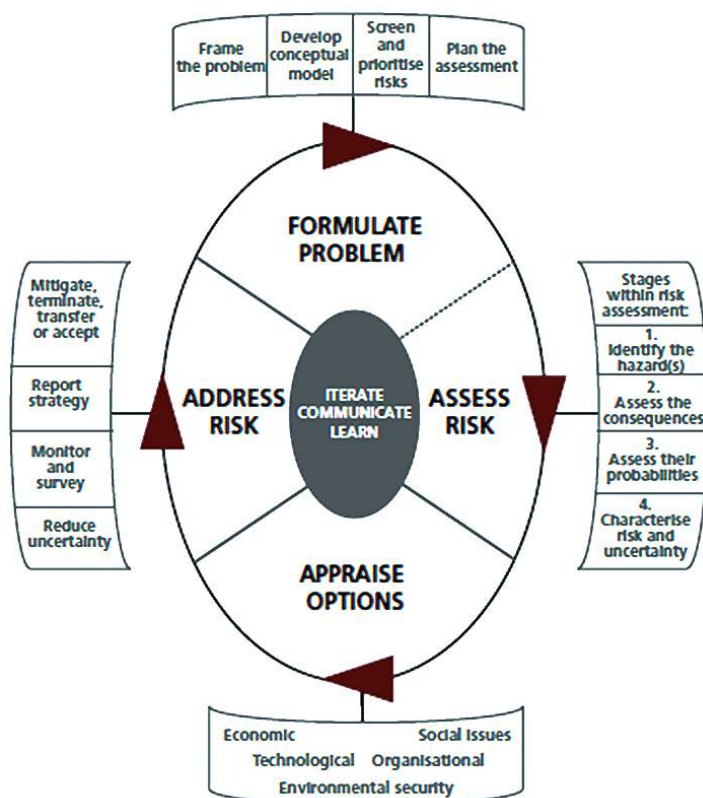

Figure 2.1 A framework for environmental management (from Defra, 2011)

This cyclical approach is particularly relevant to containment systems, and it is good practice to regularly review risk assessments for existing sites (recommendations for existing sites are provided in Section 5.3).

More sector-specific guidance is given in PPG28. The principal focus of PPG28 is on when and how to use a controlled burn as part of a firefighting strategy to prevent or reduce damage to the environment. However, the guidance is underpinned by a risk assessment methodology the principles of which are broadly followed here.

In common with many other environmental risk assessment methodologies, PPG28 uses the source–pathway–receptor model. So, for a risk to exist, all three elements have to be in place. This is illustrated

by Figure 2.2. The aim of a containment system in the context of this guide is to break the pathway between a source such as an oil tank and a receptor such as an adjacent river. The likelihood that a containment system will fail to break the pathway will depend on several factors associated with the way it has been designed, built, operated and maintained.



Figure 2.2 Source–pathway–receptor model

The concept of the source–pathway–receptor model is illustrated in Figure 2.3.

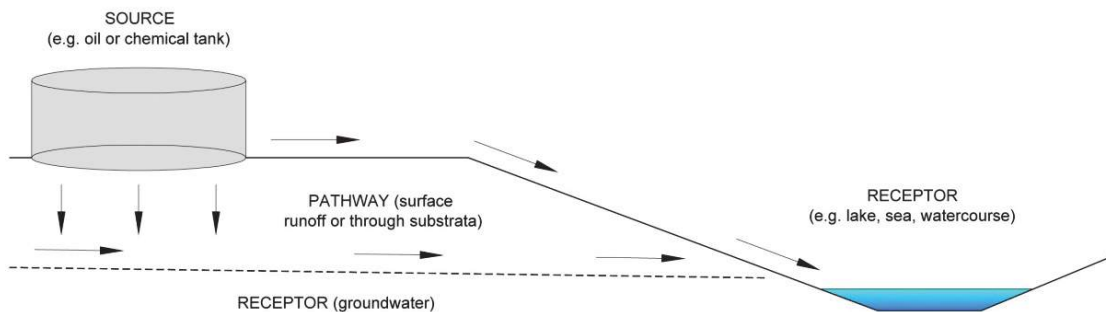

Figure 2.3 Concept of the source–pathway–receptor model

Note that where a site falls within a particular regulatory regime, ie COMAH or EPR/PPC, there are specific risk assessment methodologies that should be followed. However, there is much cross-cutting guidance prepared by the CA for COMAH and the regulator for EPR/PPC that is relevant to the methodology set out in this chapter. This, together with work by industry bodies such as the Energy Institute (EI) and the CDOIF on risk assessment, will be referenced as appropriate.

It is beyond the scope of this guide to provide advice on completing detailed risk assessments, however, the EA provide information on preparing a risk assessment to support an environmental permit (see *Websites* box at the end of this chapter). Guidance is also available in CDOIF (2013a).

CA (2012) provides advice on the selection of an appropriate risk assessment methodology such that it is proportionate to the risks involved.

In addition to extent and severity, consequence is also a function of duration of harm (both EHI and CDOIF (2013a) benchmark this against timescale for natural recovery).

2.2 FRAMEWORK FOR CLASSIFICATION OF SECONDARY AND TERTIARY CONTAINMENT

This section introduces the risk assessment framework that underpins the three-tiered classification system for secondary and tertiary containment facilities set out in this guide. The purpose of a risk assessment is to ensure that the measures put in place to manage or mitigate risk are proportionate.

It has been developed specifically to inform the design and performance of containment systems that are appropriate to the risk associated with inventory and the environmental setting. To this extent, it is

deliberately restricted in context and scope. Class 1 containment systems are provided where the risk of pollution arising from the storage of the inventory is relatively low, whereas class 3 containment systems are provided where this risk is relatively high. Part 3 gives advice on standards of design and detailing appropriate to each class for a number of forms of containment construction.



As noted in Sections 1.3 and 1.4, using a class appropriate to the risk as determined by this guide will not guarantee legal compliance and the final containment solution will ultimately depend on regime specific requirements and risk assessment methodologies. For example, if the output of the risk assessment determines that class 1 (the lowest risk) is appropriate there might still be requirements in law that requires a higher standard of containment.

An operator seeking to develop or extend a site storing inventory where no secondary or tertiary containment is proposed would have to supply clear justification to the regulators as to why it would not be necessary. The information in this chapter is not appropriate to develop any such case.

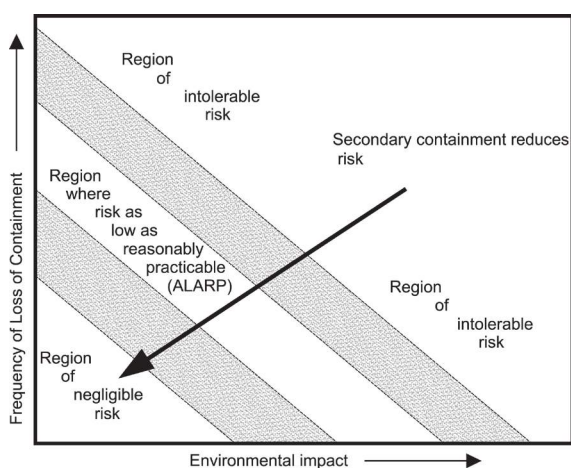

Figure 2.4 Relationship between risk, environmental impact and frequency

The relationship between risk, environmental impact and likelihood of loss of containment is shown in Figure 2.4 where different levels of risk are indicated by different regions of the chart. The overall purpose of containment is to reduce the likelihood of the escape of inventory and/or the resulting environmental impact.

It should be stressed that this diagram necessarily simplifies what is a complex set of relationships. In particular, the boundaries (represented by the shaded areas) between the regions separating the three risk levels are not in practice clearly defined.

Managing risk to be ‘tolerable if ALARP’ (TifALARP) implies that the measures to be put in place should be proportionate. This guide

therefore provides a risk assessment framework to advise on standards of design and construction for containment systems that are proportionate to the risk.

The general framework for the risk assessment is illustrated by Figure 2.5 and provides a three-step approach:

- **Step 1** applies the source–pathway–receptor model to the site to assess the hazard presented by the inventory to the surrounding environment. Chapter 2 provides guidance on how to undertake this assessment from first principles. The assessment of the source–pathway–receptor is combined in Section 2.4 to provide a **site hazard rating**. However, in many cases the nature and quantity of the inventory and knowledge of nearby sensitive receptors such as water bodies or designated habitats may be sufficient to determine that there is negligible (low site hazard rating) or, conversely, a high (high site hazard rating) risk.
- **Step 2** considers the likelihood of a loss of containment. This will depend on several factors such as the reliability of the operations and inspections undertaken on site, the conditions of the primary storage vessels and the degree they are protected from impact damage etc. Security will also be a consideration (see Section 3.7). The likelihood of a loss of containment is combined with the site hazard rating in Section 2.5 to provide a **site risk rating**.
- **Step 3** the site risk rating leads to a recommendation for an appropriate class of containment as defined in this guide.

The three classes are defined by increasing requirements in terms of design and construction integrity, the recommendations for which are set out in Part 3.

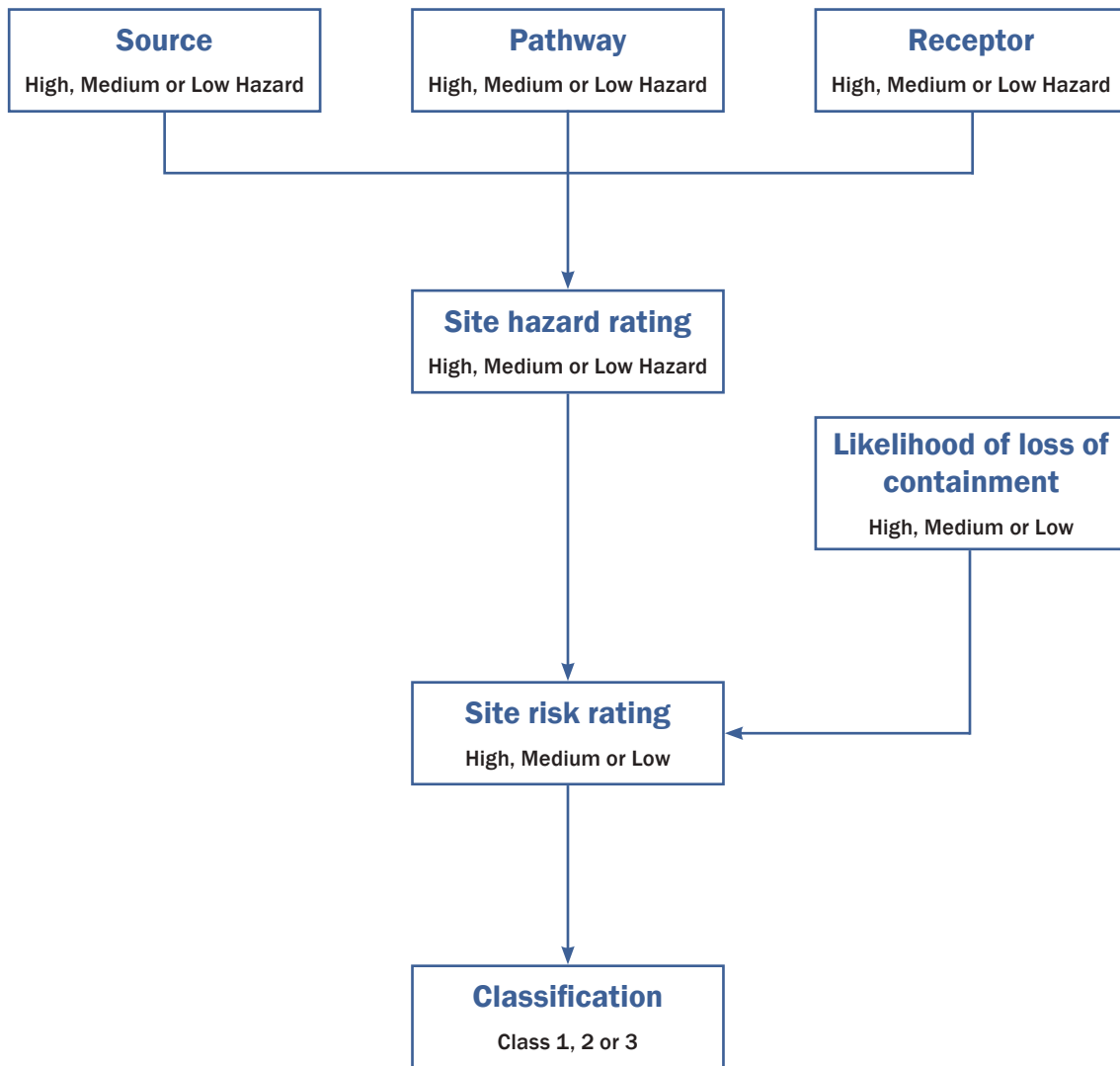

Figure 2.5 Risk assessment framework

2.3 KEY ELEMENTS FOR DETERMINING THE SITE HAZARD RATING

2.3.1 Source

Source	Pathway	Receptor
--------	---------	----------

Introduction

In the context of assessing hazard, the **source** refers to:

- the inventory
- rainwater or surface water runoff contaminated by the inventory
- firefighting agents that are harmful to the environment in their own right and/or are contaminated by the inventory
- firefighting and cooling water contaminated by the inventory.

Nature and quantity of potential pollutants

The potential pollutants present on industrial sites will comprise a range of raw materials, products, fuels and wastes. The quantity and nature of these materials should be assessed in relation to their polluting potential, the extent to which their presence may trigger or exacerbate an incident (eg highly flammable substances) and any physical or chemical properties that may call for special containment measures (eg corrosive materials that may damage concrete). In addition the potential duration of the release should be considered.

In relation to pollution potential, a wide range of characteristics of the inventory and any material used to suppress the fire should be taken into account including:

- physical properties (eg density and viscosity)
- chemical and biochemical properties (eg BOD and pH)
- ecotoxicological properties
- bioaccumulation, biomagnification or persistence potential
- by-products of fire/unwanted reactions
- contaminated firewater.

The first stage is to assess whether the individual chemicals present on site, or any combination of them, will pose a hazard to potential environmental receptors if released. The SDS will provide all relevant environmental data.

Environmental harm index (EHI)

The potential harm caused by a particular substance is a function of the sensitivity of the receptor to that substance. The **severity** of the impact is in turn a function of the potential **extent** over which spillage might occur and **duration** of the harm, ie how persistent the substance is in the particular environment. One method of quantifying the potential harm is the development of an environmental harm index (EHI) as proposed by DETR (1998) There are also a number of other work streams in this area under development that include CDOIF (2013a).

The degree of susceptibility to different substances is likely to vary from receptor to receptor. So, if more than one substance is stored on site and these are not similar, where there is a pathway it will be necessary to repeat the assessment for each substance and against each receptor as necessary.

The quantity of hazardous material present on a site is an important factor to be taken into account when considering containment capacity. There are 'threshold' quantities below which the escape to soils or controlled waters may not have a significant environmental impact. These are provided by 'chemical standards', chemical concentrations in an environmental medium such as water, air or soil that are not expected to cause harm to environmental organisms or human health, provided they are not exceeded. It should be noted that the same chemical may have several standards for different environmental receptors, and for different protection goals. Details of these standards are listed in Appendix A1.

There are a number of statutory and non-statutory standards that are set in legislation and by various organisations respectively. It should be noted that these standards may prohibit any concentrations of a substance in the environment. Information on chemical standards and statutory and non-statutory standards may be found on the EA's website (see *Websites* box).

Toxicity and hazard

An alternative method to the EHI and the work of the CA and CDOIF in classifying the source hazard is based on the toxicity and quantity of the stored substance. The toxicity is based on Regulation (EC) No 1272/2008. This Regulation makes reference to the H-Phrase of a substance defined in the Globally Harmonized System of Classification and Labelling of Chemicals (GHS) (United Nations, 2005). H-Phrases are intended to form a set of standardised phrases about the hazards of chemical substances and mixtures that can be translated into different languages (OChemOnline, 2011).

Some substances classified under the CLP, which are very toxic for the aquatic environment, have a 'multiplying factor' (M-factor) applied to give an increased weight. More information can be obtained from the HSE (see *Websites* box).

Many materials may also have LD50 and LC50 toxicity ratings. These refer to the concentration of the material that kills 50 per cent of an exposed population of test animals and the concentration in water that kills 50 per cent of the aquatic organisms within a given time period respectively. These ratings have been used to relate toxicity, quantity and hazard (see Figure 2.6).

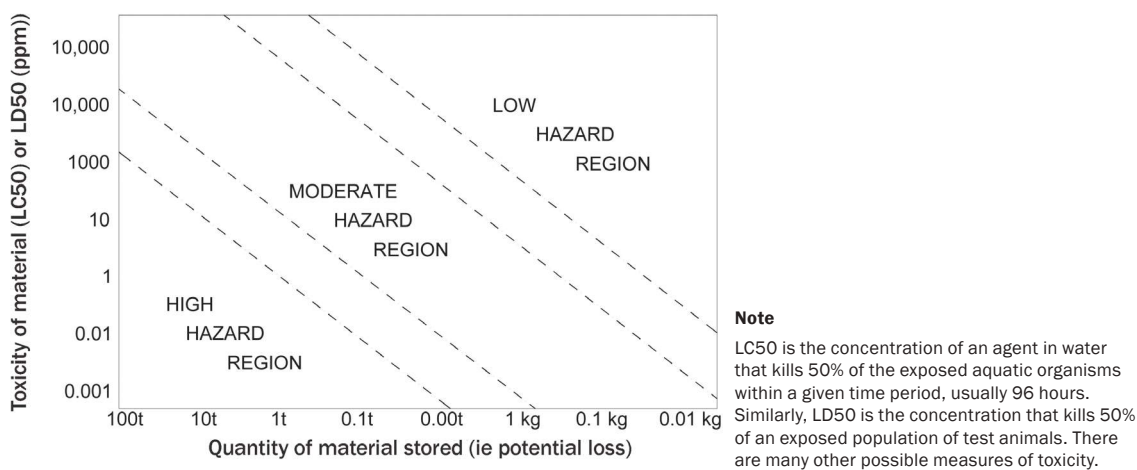

Figure 2.6 Relationship between material quantities, toxicity and hazard

Examples of inventory that, if present on site, would suggest a high source hazard irrespective of the quantity stored are listed in Appendix A2.

It is important that the polluting effects of all the possible cocktails of materials that may arise during an incident are taken into account. This is a particularly important consideration in warehouse situations and across large sites where many different materials may be stored together and there is a risk that they could be released simultaneously into the environment.

Effects of fires and firefighting water

On many industrial sites, one of the most significant hazards is fire. The potential effects of a fire can alter the assessment of source hazard in a number of ways, including physical or chemical modification of the materials on site and damage to other primary containers, which could result in further materials being released.

By far the most important effect of fire, in the context of considering **sources**, is the introduction of potentially very large volumes of water used to extinguish fires and to cool adjacent containment (collectively termed firefighting water in this guide) and, to a lesser extent, foams. Firefighting water will become contaminated on contact with the inventory and so it is just as important to control its release to the environment as it is with the inventory itself. Sites where flammable inventory is present should be considered as a high source hazard rating. Methods for estimating volumes of cooling and firefighting water and foam are presented in Section 4.3.3.

2.3.2 Pathway

Source	Pathway	Receptor
--------	---------	----------

This section provides:

Guidance on how to identify and assess the potential pathways between the source and the receptor and how to assess the hazard rating of the different pathways. It considers:

- proximity of receptors
- firefighting water
- site layout and drainage
- treatment plants
- topography, geology and hydrogeology
- mitigating effects
- climatic conditions
- factors affecting transport potential.

Introduction

Pathways are the means by which a hazardous substance would reach a **receptor**. The area of search for potential receptors is governed by the potential pathways and these might include:

- simple overland flow following the local topography
- existing pipes, sewers, drains or other underground features that could lead to a receptor such as a watercourse
- permeable sub-soils and strata underling a site that could provide a pathway to groundwater or a watercourse.

Multiple combinations of pathways may exist and should be considered.

In considering the hazard rating of potential pathways the following should be considered:

- 1 The distance between the source and the various potential receptors.
- 2 Site layout (including topography), and the position and effectiveness of drains and other internal and external pathways.
- 3 Geographical, geological and hydrogeological features that could either impede or facilitate escape of inventory from the site. In addition building foundations may impede or alter sub-surface drainage paths.
- 4 Climatic conditions and expected variability.
- 5 The direct effects of fire and the introduction of firefighting water, or foam.
- 6 The presence of treatment plants (on or off site).
- 7 Modification of the inventory during passage through the pathway such as the cooling of a liquid.
- 8 Inventory that is not particularly mobile in ambient conditions may be soluble in water.
- 9 The scale of potential incidents (larger incidents and firewater generally have greater potential for mobilisation in the environment than smaller spills).

The time it would take for an inventory to reach a receptor is an important factor. The potential for the substance to harm the environment is higher if it reaches the receptor quickly since:

- there will be less opportunity to contain the inventory (either on site or off site) and prevent escape to the wider environment
- mitigation of the effects of the substance by such factors as evaporation or dilution will be reduced
- there will be less time to warn other organisations and individuals likely to be affected, eg the regulator, downstream landowners and water users, and sewage treatment plant operators.

In cases where the escape of inventory goes undetected, particularly over a long period of time, there will be no opportunity to put mitigation measures in place in a timely manner. The presence of leak detection systems should therefore be taken into account when assessing the hazard rating for pathways.

However, if the time it takes for the inventory to reach a sensitive receptor and cause harm is long, then a planned and tested mitigation strategy may well reduce the impact or prevent damage to the receptor.

By taking into account the factors outlined above it is possible to derive a hazard rating for the pathway. In the same manner as the source hazard, ie this is designated a high, moderate or low according to the particular characteristics of the pathways.

Proximity of receptors

It is important first to identify all of the possible receptors and their locations in relation to the source to be able to assess the relevant pathways. However, judgement will be required in the first instance to make an assessment of credible pathways to set reasonable limits on the area of search for potential receptors.

Potential pathways for overland flow will be determined by the local topography and to an extent the permeability of the near surface soils. Where permeable soils are present, the interaction with groundwater should be considered, which in itself is both a potential pathway and receptor.

Sewers, culverts and drains all have the potential to convey inventory rapidly away from a site and to release them into the environment many kilometres from the site boundary. Even where the sewers, culverts and drains are sealed, the bedding and surround may act as pathway for rapid off site migration.

Permeable substrata can also convey inventory over large distances where they can affect ground and surface water resources. Potential sources of information on groundwater are given in Box 2.2 and the regulator should also be consulted.

Site layout and drainage

The layout of the plant, buildings, roadways, hardstandings and other features, and the surface finish and permeability of the surfaces over which the hazardous substance may flow in the event of an escape, are all relevant factors in deriving hazard rating.

The following issues will tend to increase the hazard rating for pathways:

- 1 Hardstandings around the primary containment sloping towards a surface receptor.
- 2 Primary containment installations surrounded by flat or slightly sloping permeable ground permitting infiltration to groundwaters.
- 3 On-site effluent drainage systems that provide pathways to trade effluent outfalls, to public sewers, or to on- or off-site public treatment works.
- 4 The presence of below-ground features such as services, ducts, pipelines, filled ground, tunnels, tanks or sumps.
- 5 Other man-made pathways such as old mine workings, storm drains and gullies, culverted watercourses and land drains located close to the source or potential pathway.

Rainwater soakaways are a common feature on many sites. The proximity of soakaways to sources of inventory, their location with respect to physical pathways, the possibility of their contamination in the event of an incident, and even their use in principle, need to be carefully reviewed.

Where soakaways are provided as means of rainwater disposal, the potential pathways via infiltration and groundwater as a potential receptor should be fully assessed.

Topography, geology and hydrogeology

The topography of the site and the permeability of the ground will have an effect on the transport of inventory to surface waters and infiltration to groundwaters. On large sites there may be a considerable variation in landform, soil type and geology across the site, which will influence runoff and infiltration.

With the exception of some small sites where the ground conditions are well known, geotechnical and hydrogeological surveys should be carried out on sites where inventory is to be stored.

This will be particularly important where the ground is to be used as part of the containment system, ie earth embankment bunds and lagoons.

Topographic survey data may also be required to confirm potential overland flow paths.

Climatic conditions

Climatic conditions, including precipitation and temperature, can affect ground conditions and permeability, vegetation and evapotranspiration, each of which can affect the pathway. Frozen or saturated ground will increase the tendency for rapid runoff from areas where, at other times, runoff may be very much slower or absent altogether. Surface cracks and fissures in dry conditions will increase infiltration and may provide direct pathways to permeable substrata and groundwater.

The consequences of the failure of a containment system during a period of heavy rain need to be taken into consideration. One possible beneficial effect may be that the rain will dilute the inventory before it reaches the receiving water. However, the higher runoff volume may increase the possibility of it reaching the receptor.

Areas that are susceptible to persistent and/or widespread flooding can also provide a pathway for hazardous substances released from the primary containment. Information on areas potentially at risk of flooding from surface water runoff, rivers and the sea is available from the EA, SEPA and DARDNI (see *Websites* box).

A particular issue is operation of combined sewer overflows (CSO) during periods of heavy rainfall. A combined sewer caters for both foul (including, where consented, trade effluent) and surface flows. CSOs were constructed to reduce the risk of sewer surcharge, flooding or overwhelming the wastewater treatment works (WwTW) during periods of heavy rainfall that discharge to a local watercourse. These CSOs therefore have the potential to provide a direct pathway to a receptor by bypassing the WwTW.

Firefighting water

Firefighting water has the potential to dilute very significantly any hazardous substance released from the primary containment. However, in the same way as heavy rain, it may also affect the pathway. If the flow of firefighting water is greater than the capacity of the site drains, the contaminated firefighting water will find other pathways from the site. Forecasting the pathway of the inventory, taking into account the effects of heavy rain or firefighting water, or even both together, is a key factor in assessing pathways.

Another important consideration is the effect that fire may have on the flow properties of the hazardous substance, particularly in the site drainage system. Fire and heat may cause increases in viscosity or surface crusting so that flow through the system is slowed down or even stopped completely. Conversely, fire may melt or destroy site features that under normal circumstances would divert flows elsewhere. Drains may also become blocked through debris flushed into them by the firefighting water.

Treatment plants

Pathways may lead to, and include, effluent treatment works on the site, or WwTW off site. The unplanned entry of highly polluting effluent into a treatment plant at a level that exceeds the treatment or containment capacity of the works may cause major damage, which effectively puts the plant out of action. The damage may be long-term. The resulting discharge from the damaged works may result in more serious pollution than would have resulted from a direct discharge of the primary pollutant.

WwTW, and particularly those catering for combined sewers, are often provided with storm tanks to balance the load through the works. If the duty holder notifies the works as soon as the incident occurs,

these storm tanks, if provided, may contain any spillage from the primary containment that enters the upstream drainage network potentially interrupting a significant pathway.

Mitigating and exacerbating effects

When inventory escapes from the primary containment, it may be subject to a number of factors that alter its environmental impact potential, either by modifying its properties or its volume.

In assessing possible mitigating effects, the factors that should be taken into account include:

- likelihood of dilution in the drains
- possible dilution and treatment at on-site or off-site treatment plant (note that such plant could be severely affected by the pollutant and to that extent can equally be regarded as a receptor)
- chemical reactions (eg materials may be highly reactive with water)
- application of neutralising agents that might dilute the escaped inventory
- evaporation (eg volatile solvents)
- absorption (some materials may be absorbed by soil or other solids)
- settling (some materials may settle in drains, interceptors or lagoons)
- existing retention capacity on the site.

Note that simply diluting escaped inventory as part of spill management is not considered good practice.

Exacerbating factors might include:

- larger volumes tend to spread further
- greater slopes result in faster runoff and less time to act to intercept
- inventory spread over large areas at shallow depth may be more difficult to recover
- adverse chemical reactions between differing inventories released during an incident.

Factors affecting transport potential

Examples of pathways where the hazard rating is considered to be high might include:

- short runoff time between source and receptor
- direct drainage links between source and receptor (or treatment plant where this could be considered a receptor)
- absence of holding capacity in drains and sewers
- highly permeable strata between source and groundwater receptor
- absence of treatment facilities
- little to mitigate the effects of the released hazardous substance
- flooding.

2.3.3 Receptors

Source	Pathway	Receptor
--------	---------	----------

This section provides:

Guidance on how to identify the various receptors and their susceptibility to harm from the sources and via the pathways identified. It considers:

- environmental sensitivity
- other factors
- uncertainties
- nature and classification of receiving waters
- wastewater treatment works
- dilution and mixing.

Introduction

A receptor includes humans, animals, fish, plants and biota, watercourse or body, groundwater or soils that would be affected (directly or indirectly) by the escape of the inventory. A receptor could also be a downstream process such as a WwTW.

To assess the impact of a hazardous substance release on receptors, it is first necessary to identify any that could be affected. The hazard rating completed for pathways should be used to inform the area of search. Useful information on the presence and nature of environmental receptors in the vicinity of the site may be obtained via site inspection and the study of local maps. Additional information may be held by local authorities, countryside and heritage commissions, and the various regulators. Other potential web-based sources are listed in Table 2.2.

Table 2.2 Sources of information for environmental receptors (accessed 29 May 2014)

Source	Website link	Information
Environment Agency <i>What's in your backyard?</i>	http://tinyurl.com/ntx7agd	This site provides information on flood risk, groundwater vulnerability, aquifers, nitrate vulnerable zones and river water quality for sites in England and Wales. No similar information is currently available for Scotland
British Geological Survey Geology of Britain maps	http://tinyurl.com/6ssf79p	Maps provide descriptions of the solid and superficial geological deposits. While the potential permeability of the soils, and the likelihood that pollutants could affect groundwaters, is not always clear from the descriptions, of particularly high potential risk would be sands and gravels and chalk
Natural England <i>Sites of Special Scientific Interest</i>	http://tinyurl.com/c637z6	Provides information on Sites of Scientific Interest (SSSI) and Special Protection Areas (SPAs) in England
Countryside Council for Wales <i>Special landscapes and sites</i>	http://tinyurl.com/oqjvq4x	Provides information on designated sites in Wales (note that this information may be ported to the Natural Resources Wales (NRW) website in due course)
Scottish Government <i>Where are SSSIs found?</i>	http://tinyurl.com/ntsvk2t	Provides information SSSI and SPAs in Scotland
Defra <i>Special Areas of Conservation</i>	http://tinyurl.com/opthzqn	A listing of SACs in the UK
Joint Nature Conservancy Council Ramsar sites in the UK, its overseas territories and Crown dependences	http://tinyurl.com/ph6r3pr	Information on Ramsar (bird protection) sites
Ancient Monuments	www.ancientmonuments.info	Information on the designation of Scheduled Monuments in the whole of the UK
MAGIC <i>Interactive mapping</i>	http://tinyurl.com/nso8tb7	Is a web-based interactive map provided by Defra that brings together information on key environmental schemes and designations in one place, including some of the sources listed above

The presence and nature of the receptor can generally be thought of as a fixed point in any hazard or risk assessment. However, in areas at risk of flooding, there may be circumstances where the location of the receptor may change, ie where the flood waters themselves would be considered a receptor. Although the site operator is able to modify sources and, to some extent perhaps, on-site pathways, altering the location of the receptor is more difficult.

WFD objectives should be noted when assessing the sensitivity of the receptor as it should be taken as its future potential rather than current condition.

As with source and pathway, a receptor is assigned a hazard rating according to its sensitivity to the hazardous substance, ie high, moderate or low.

Environmental sensitivity

Potential receptors should be discussed with the regulator and agreement reached on which of them are sensitive to harm from the hazardous substance(s) stored on the site. As noted in Section 2.4, if there are several different inventories stored at a site then each of these could affect each receptor in a different way.

Other factors

There are other factors that may reduce or increase the severity of the environmental impact. Mitigating factors include:

- biodegradation (eg compounds broken down by microbes)
- evaporation
- photolysis (eg compounds broken down by sunlight)
- hydrolysis (eg compounds broken in water)
- absorption (compounds absorbed by another substance, for example the deployment of chemical spill kit).

Aggravating factors include:

- bioaccumulation (eg in fish)
- biomagnification (eg along a food chain)
- biodegradation (eg discharge of inventory with a high biological oxygen demand).

The rate at which these effects mitigate or aggravate environmental impacts depends on a variety of interacting circumstances, but in some cases it is quantifiable.

Analysis of these mitigating and aggravating factors is a complex task. If these are likely to be significant factors in determining a hazard rating for a receptor, ie high, moderate or low, the advice of a competent person should be sought.

Uncertainties

There are considerable gaps in the knowledge when it comes to quantifying the effects of inventory on receptors. In particular, toxicity effects on man and ecotoxicity effects on ecosystems are only readily available for those substances commonly used in industrial and manufacturing processes.

The hazardous substance may not be a single chemical, but may be, for example, a complex mixture of hydrocarbons as in fuels or oils. In such cases it will be necessary to consider whether to assess all individual chemicals separately, or to treat the mixture as a single substance using available whole product data.

Nature and classification of receiving waters

The EA (2013a) uses aquifer designations that are consistent with the WFD. These designations reflect the importance of aquifers not only in terms of groundwater bodies as a resource (drinking water supply) but also their role in supporting surface water flows and wetland ecosystems. Geological units are broadly divided into principal aquifers, secondary aquifers and non-productive strata. Further information on aquifer designations may be found on the EA's website for England and Wales, and on SEPA's website for sites in Scotland (see *Websites* box).

Wastewater treatment works

On-site effluent treatment plant and off-site WwTW may be considered as receptors. The normal functions of the plant could be impaired for a long period by the entry of materials incompatible with normal treatment processes. For example, all biological treatment plants depend on the activity of bacteria to break down complex organic compounds. The uncontrolled discharge of substances such as pesticides, hypochlorite, metals, organochlorine solvents and acids and alkalis is likely to kill the bacteria

and halt biodegradation processes. Equally, overloading the plant with non-hazardous but high BOD substances can disrupt performance. It could take a treatment plant many weeks to return to its previous level of biological activity. In this period, the plant could not carry out its normal function and sewage and trade effluents would have to be removed off-site for treatment elsewhere.

The effects of pollutants on WwTW need to be considered in the hazard assessment. Tolerable levels and loads of inventory should be established in collaboration with the treatment plant operators particularly in respect of their trade effluent consents. In some situations it is possible that a treatment plant will be the critical receptor.

Dilution and mixing

Receptors may be located many kilometres away from the point at which the inventory is released into the environment. Where the pathway includes surface or groundwaters (receptors in their own right) dilution and dispersion takes place that can mitigate the potential impact. However, in general, regulators would not condone dilution and dispersion in the water environment as a means of mitigation, except as an authorised discharge.

If there is a risk of inventory entering the water environment, regulators would expect to see AMN/BAT applied to reduce that risk. Modelling may, however, be used to demonstrate the effect of residual risk following installation of AMN/BAT, or for assessing impact of a major accident of low frequency. There are a number of dispersion models available ranging from the simple to the extremely complex and the appropriate choice of which will be governed by the potential risk to the receptor. Depending on the complexity of the model to be used, the following information is likely to be required:

- duration and mode of release
- flow of the receiving water and dilution potential. This should also consider periods of low flow where the dilution potential may be limited
- background levels of the inventory
- tidal influences (if any)
- mixing characteristics, stratification, turbulence etc
- density and solubility of the inventory (is it miscible with water, will it float or sink?)
- climatic conditions and the impact of climate change.

Dispersion modelling is a complex process and should be completed by a competent person. The scope of any such model should be agreed in advance with the regulator.

2.4 OVERALL SITE HAZARD RATING

The preceding sections provide an approach to determining a hazard rating for the source, pathway and receptor. The three factors are now combined to obtain an overall site hazard rating designated as **high**, **moderate** or **low**.

There are a number of ways in which the individual factors can be combined, particularly if a different weighting is given to each factor, as may be appropriate in some circumstances. However, assessing the combined effects has to be a judgement based on knowledge, experience and the degree of confidence in the information available. Where there is uncertainty about the correct categorisation of any of the individual source, pathway or receptor hazard ratings, it may be appropriate to move the overall site hazard rating to the next higher rating, ie from medium to high.

It should be stressed that it is likely to be necessary to consider multiple source, pathway and receptor scenarios. For example, there may be one pathway to groundwater and another to surface water, each of which needs to be considered separately. Similarly it may be necessary to consider a number of receptors, since it may not be clear initially which of these is the most environmentally sensitive. The site hazard rating adopted should represent the highest of the individual scenarios considered.

A further issue is a large site where multiple sources of inventory are stored but share secondary containment facilities. As the site hazard rating is used to inform the class of the secondary containment, it is the highest site hazard rating for the combination of source, pathway and receptor estimated for the sources within the particular facility that should be used.

The only exception to this may be where multiple sources are stored in separate secondary containment facilities, ie the site is 'zoned' (see Section 3.7) in which case the site hazard rating should be applied on a zone by zone basis.

If the analysis indicates that the hazard rating of any one element in a combination of source, pathway and receptor is negligible, then the site hazard rating for this particular combination is also considered to be negligible.

Typically, if the three factors are given equal weighting, they may be combined in the way illustrated in Box 2.1 to give an overall site hazard rating.

Box 2.1 Suggested combinations of hazard ratings to give overall site hazard rating

Environmental hazard ratings		
H = High rating		
M = Moderate rating		
L = Low rating		
Source	Pathway	Receptor
(hazard rating)	(transport potential)	(damage potential)
May be H, M or L	May be H, M or L	May be H, M or L
Possible combination of ratings:		Suggested consequent overall site hazard rating:
HHH or HHM or HMM		HIGH
HHL or MMM or HML		MODERATE
MML or HLL or MILL or LLL		LOW

As a general guide it can be anticipated that regulators' initial expectations in terms of the components of the site hazard rating will be as follows:

Source hazard

- Main inventory at COMAH establishments likely to be high.
- EPR establishments likely to be **high/medium**.
- EPR exempt establishments likely to be **medium/low** (though some could be **high**, eg certain large storage facilities otherwise exempt from COMAH/EPR).

Receptor hazard

- Nationally designated sites (SSSIs/SPAs/SACs) and drinking water sources (source protection zones) are likely to be **high**.
- Locally designated sites, surface or groundwater bodies defined as such by the WFD are likely to be **medium**.
- Non-designated sites and other water and groundwaters are likely to be **low**.

When considering the overall site hazard rating regulators would normally refer to the Compliance Classification Scheme (CCS) and the Common Incident Classification Scheme (CICS) (see *Websites* box), which defines a scale of incident impacts and informs their enforcement stance. Therefore, it would be anticipated that overall site hazard rating would be:

- **High** for potential for CICS category 1 (or MATTE) incidents.

- **Medium** for potential for CICS category 2 incidents.
- **Low** for potential for CICS category 3 incidents.

In consultation with the regulators, the assessment may be ended at this stage if it is concluded that decisions regarding containment can be made based on the site hazard rating. It should be noted that the regulators are likely to require containment provisions for sites with a high hazard rating.

Alternatively, the assessment may be developed further to combine the site hazard rating with the likelihood of all events, which could lead to loss of containment and quantifying their impact on the environment.

2.5 SITE RISK RATING

The preceding sections are concerned specifically with hazard assessment. To assess the risk it is necessary to consider the events that may lead to the release of inventory from the primary containment and the likelihood that this would occur, ie:

- 1 Identification of all the events that are capable of causing loss of containment.
- 2 Assessment of the likelihood of occurrence of each event.

The potential failures and the reasons for failure include:

- operational failures, such as failure of plant, or human failure by operators
- shortfalls in design – lack of alarms and fail-safe devices
- structural failure – materials, components, detailing, corrosion or when exposed to heat and flame
- abuse – inappropriate change of use or other misuse
- impact, eg from a vehicle
- vandalism, terrorism, force majeure etc
- flood, fire or explosion
- geological factors -subsidence etc
- ageing or deteriorating assets/sub-components.

Where the need has been identified, a detailed investigation of the reasons for the potential failure of plant and equipment may be carried out with the help of a variety of techniques including hazard and operability (HAZOP) studies, fault tree analysis (FTA) or failure, mode and effect analysis (FMEA). These studies are normally carried out by teams led by engineers specialising in the safety and reliability of processes working with maintenance and operating practitioners.

The effects of changes in the nature, size or frequency of potential releases as a result of actions taken may be modelled using risk assessment techniques. It is also the case that general risk management procedures can assist with avoiding potential releases of inventory and that incident management can include measures other than the provision of containment.

Where company or plant specific failure rate data are not available, reference to the data provided in Appendix 1 of CA (2012) should be made. This provides data on the risk of tank and associated infrastructure failure, tank and bund fires and warehouse fires drawn from a literature review of historic information.

By analysing the events and circumstances that may affect a site it is possible to arrive at an assessment of the probability of a loss of containment and release of inventory expressed a low, medium or high. It is unlikely to be possible to precisely estimate the probability of a failure of the primary containment and/or secondary containment due to the inherent uncertainties involved. It is therefore advised that any such estimates that are made to inform the classification and of the design processes are discussed with the regulator.

However, as a general guide, the following typical probabilities might be considered appropriate for use in establishing the site risk rating.

Table 2.3 Frequency of loss of containment

Risk of loss of containment	Annual probability of loss of containment per site
High	Greater than 1% (1 in 100)
Medium	Between 1% (1 in 100) and 0.001% (1 in 1 million)
Low	Less than 0.001% (1 in 1 million)

Typical examples of incidents that could lead to a loss of containment (listed in order of reducing probability) might include:

- small spills
- pipe failures
- single IBC incident
- localised flooding
- site-wide fires
- whole vessel failures
- major flooding
- vandalism
- subsidence
- terrorism
- plane crash
- earthquake.

It will also be necessary to consider multiple credible potential failure scenarios.

The combination of site hazard rating, with the frequency of loss of containment, provides an assessment of the overall site risk. The ways in which the ratings for hazard and risk can be combined to provide an overall site risk are shown in Box 2.2 where the hazard and the probability are given equal weighting.

Box 2.2 Overall site risk rating as defined by combining ratings of site hazard and probability of containment failure

Site hazard ratings	
May be high (H), moderate (M) or low (L) (see Box 2.1)	
Frequency of loss of containment	
May be high (H), moderate (M) or low (L)	
Possible combination of ratings:	Suggested consequent overall site hazard rating:
HH or HM or MH	HIGH
MM or HL or LH	MODERATE
LL or ML or LM	LOW

Where the risk assessment indicates that an event could result in significant environmental damage at an intolerable frequency, the operator or designer would need to consider one or more of the following risk reduction measures:

- change to less hazardous or reduce inventory
- change or relocate the process or activity to a less environmentally sensitive location
- install new, or improve existing, containment systems (the subject of this guide)
- provide smaller storage units
- modify the on-site pathways to minimise the likelihood of escape of pollutant
- change or relocate the process or activity
- change operational and/or management practices.

As with the classification of hazards, there are many uncertainties and gaps in current information. Combining ratings for hazard and frequency of loss of containment as described previously calls for skill, experience and judgement if sensible and useful conclusions are to be drawn. There are likely to be some distinctly high risk or low risk situations that are relatively easy to define and classify but the majority of

situations will necessarily require some subjective judgements to be made. Key stakeholders including plant operators, regulatory bodies and designers should be consulted throughout the risk assessment and design process.

The hazard and likelihood rating combinations HL and LH in Box 2.5 are perhaps the most difficult to classify in terms of overall site risk, although the recommendation is that they are given a moderate rating. There are likely to be many situations where the hazard rating is high but where the probability of an event causing loss of containment is low. Views on how this situation should be treated may differ and there should be full consultation with the regulator at the start of the process.

Sites scoring a low risk rating are not likely to require further assessment, subject to all site conditions remaining the same. However, when any of the source, pathways or receptors are assessed as a high hazard then a detailed risk assessment should be undertaken by a competent person.

An alternative framework for determining the overall site risk is presented in the CA (2012) based on the EHI. This is combined with likelihood of occurrence (frequency) graphically (see Figure 2.7) and provides three zones, an 'area of concern', 'need to demonstrate risks are ALARP' and 'broadly acceptable'.

Figure 2.7 indicates how the low, medium and high overall site risk relates to the three zones.

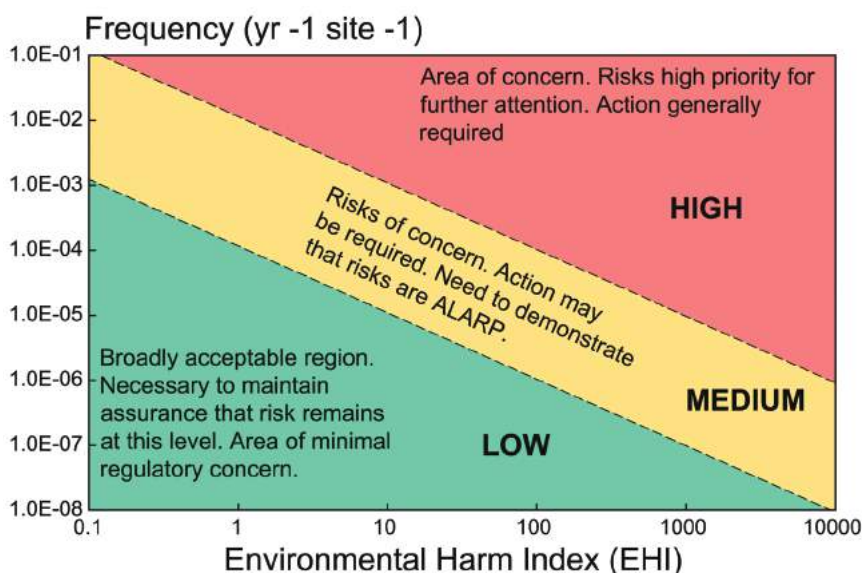

Figure 2.7 Establishment risk threshold frequencies (per receptor) (from DETR, 1998)

2.6 CONTAINMENT CLASSIFICATION SYSTEM

2.6.1 Hazard and risk assessment and design classification

This guidance sets out a classification of containment systems based on three categories (classes 1, 2 and 3) each representing a different level of integrity to match the different requirements of high, moderate and low overall site risks. However, it should be noted that legal requirements for containment systems such as the OSR would have priority above any advice contained in this guidance.

Although there is no direct quantifiable link between the site hazard or site risk and the design of the containment system the following simple relationship is considered appropriate in most circumstances:

- low overall site risk containment type **class 1**, ie base level of integrity
- moderate overall site risk containment type **class 2**, ie intermediate degree of integrity
- high overall site risk containment type **class 3**, ie highest degree of integrity.

The difference in performance between the three classes of containment can be expressed in terms of:

- system safeguards (eg whether or not fail-safe alarms form part of the system)
- system and component redundancies (eg whether there are back-up collection and storage facilities in the event of the failure of containment)
- structural integrity and quality of construction (eg increasing design requirements)
- operation and maintenance (eg enhanced inspection and maintenance regimes).

A suggested approach to the system design for a secondary containment system is outlined by the flowchart in Figure 2.8.

The detailed design guidance presented in Part 3 of this guide is based on these three classifications.

Websites

Horizontal guidance for preparing risk assessments:

<https://www.gov.uk/government/collections/horizontal-guidance-environmental-permitting>

Chemical standards: <http://evidence.environment-agency.gov.uk/ChemicalStandards/home.aspx>

Seveso Directive: www.hse.gov.uk/seveso/index.htm

Compliance Classification Scheme (CCS) and the Common Incident Classification Scheme (CICS): <http://tinyurl.com/nbc2mby>

Flood risk:

Department of Agriculture and Development (Northern Ireland) Flood risk:

www.dardni.gov.uk/index/rivers/strategic-flood-map-ni.htm

Flood risk: <https://www.gov.uk/browse/environment-countryside/flooding-extreme-weather>

SEPA: <http://map.sepa.org.uk/floodmap/map.htm>

Aquifers

Environment Agency: <http://apps.environment-agency.gov.uk/wiyby/117020.aspx>

SEPA: Water body classifications: www.sepa.org.uk/water/monitoring_and_classification/classification.aspx

Accessed 29 May 2014

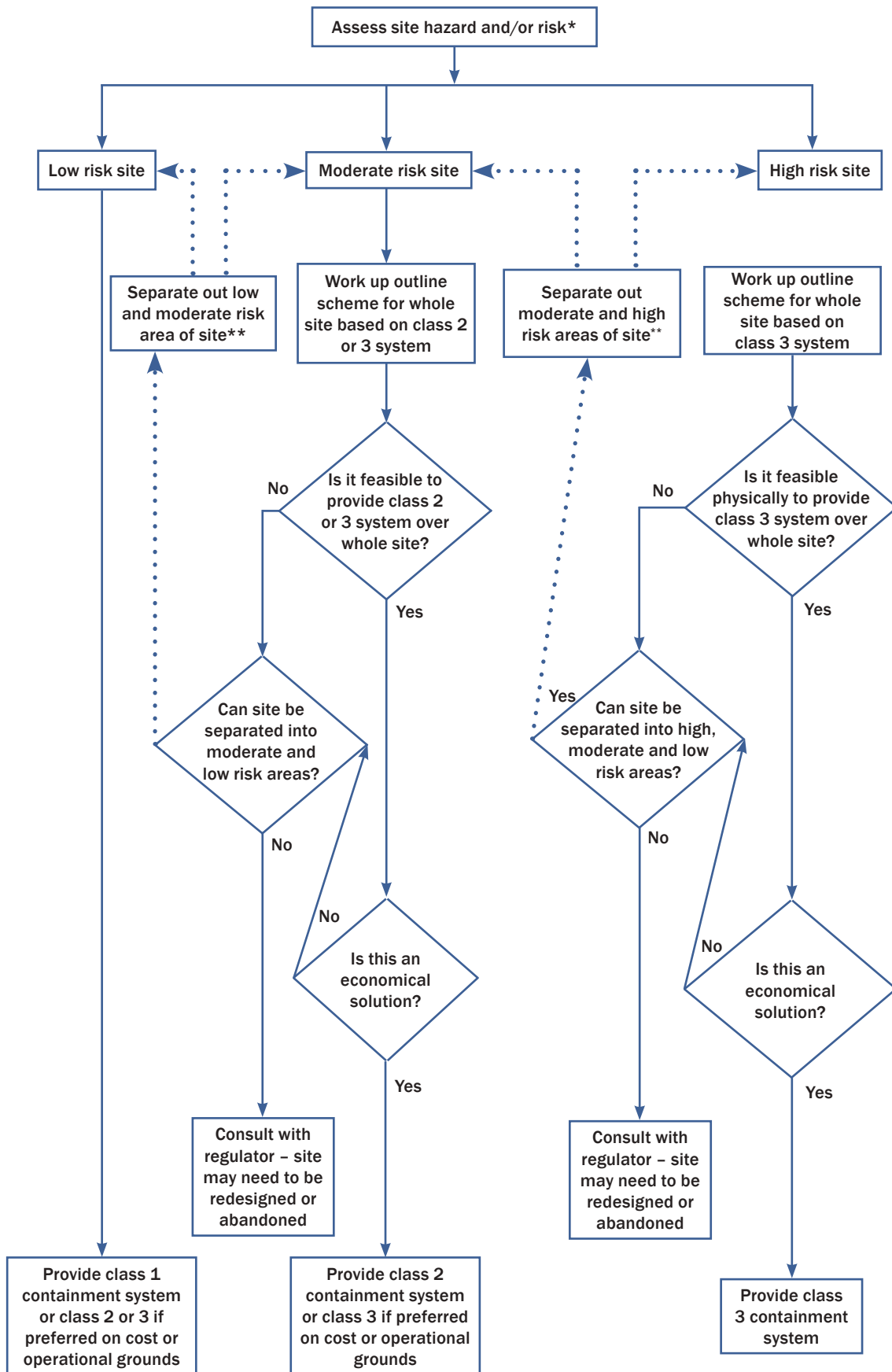

Notes

* The expression 'hazard and/or risk' is abbreviated to 'risk' in the flowchart.

** Beyond these points in the iteration, for 'site' and 'whole site' read 'area' and 'whole area' respectively.

Figure 2.8 Containment system classification

3 Secondary and tertiary containment options

This chapter provides:

- An introduction to containment system selection (Section 3.1)
- Details of containment options (Sections 3.2 to 3.5)
- Recommendations for system selection and site zoning (Section 3.6)
- Advice on considering overall system reliability (Section 3.7)

3.1 INTRODUCTION

System selection is an important first step in the design process and should be informed by the site risk rating, which is the outcome of the risk assessment process described in Chapter 2.

System selection may also be influenced by the required containment volume, which is estimated by following the guidance provided in Chapter 4.

Additional considerations to selecting an appropriate containment occur where the site falls within the scope of the COMAH Regulations, the OSR, the EPR and equivalent regulations, or the reservoir safety legislation included as part of the FWMA. However, in the absence of regime specific requirements, this guidance reflects current good practice for the design and maintenance of containment systems for the prevention of pollution. Following these guidelines will help businesses manage their environmental responsibilities to prevent pollution and comply with the law.

If the system is inappropriate for the site, then no matter how much care is taken over the detailed design and construction of the components, the result is likely to be unsatisfactory either in terms of performance, or cost, or both.

3.2 CONTAINMENT SYSTEM TYPES

Containment systems may be categorised broadly as either local (eg bunds), remote or combined (combined local and remote).

The differences between the three methods of providing containment, the situations in which they may be suitable and the protection that they can afford are described in the following sections. The examples given in this chapter refer to bunds although there are other options for providing containment such as earth embankments and for remote containment, tanks and lagoons.

There is no universally recognised definition of the term ‘bund’, however, in the context of this guidance, a bund is defined as (Mason *et al*, 1997):

“a facility (including walls and a base) built around an area where potentially polluting materials are handled, processed or stored, for the purposes of containing any unintended escape of material from that area until such time as remedial action can be taken. Bunds are usually structurally independent from the primary containment tank”

3.3 LOCAL CONTAINMENT SYSTEMS

Bunds provide a container designed to prevent the spread of any inventory that escapes from the primary containment. They contain the material at source, hence the term local containment.

Storage tanks, IBC/drum stores or other areas used for storing or handling inventory may be banded individually or in groups. However, bunds may also be built inside buildings, eg warehouses used for storing chemicals, that may be specially built or modified so that the structure itself provides an effective bund.



Figure 3.1 Typical storage of IBCs in a warehouse (courtesy Feedwater Ltd)

Bunds can also be used in linear form to protect against leaks from pipework. For pipework laid below ground the bund normally takes the form of a covered channel or culvert, although below-ground pipework should be avoided where possible. However, as these linear bunds will usually have only a small capacity and the volume of potential leakage from pipework can be large, it is good practice to arrange them to drain or overflow into larger local or remote secondary and/or tertiary containment areas.

3.4 REMOTE CONTAINMENT SYSTEMS

Remote containment systems retain escaped inventory at a location that is not local to the primary container. These systems would rarely provide any significant containment at the source of failure and so they rely principally on the capacity of the transfer system to convey spillages at a rate no less than the potential flow that would be generated by a sudden (catastrophic) loss of primary containment. Guidance on transfer systems is provided in Chapter 10.

A clear advantage of a remote containment is that a single facility can be designed to serve a number of primary containment areas. However, the design of such a 'shared' facility has to cater for the most hazardous of the substances stored on site as well as considering the potential cocktail of substances that might be retained during a site-wide incident as well as simultaneous or 'domino' events.

It is not always possible to make a clear distinction between a remote secondary containment facility and tertiary containment where the tertiary containment is provided in the form of a permanent facility such as a lagoon. However, following guidance on system capacity provided in Chapter 4:

- **Secondary containment** includes the volume of the inventory stored in the primary containment, plus the allowance made for rainwater, cooling water and firefighting agents (foam) but not necessarily firefighting water.
- **Tertiary containment** would include anything beyond this including an allowance for firefighting water. However, tertiary containment is also a line of defence for failure of secondary containment.

Additional guidance on tertiary containment can be found in EI (2013).

Transfer to tertiary containment may be through a drainage system (above or below ground), or over the surface of appropriately graded areas of hardstanding or formations and, as such, remote systems are best suited to sloping sites where the transfer system can work under gravity.

However, if the transfer system has to rely on pumping, additional measures should be provided for class 2 and 3 sites and these might have a bearing on the design of the secondary containment (see Section 10.3).



The integrity and capacity of the transfer systems clearly influences the level of protection that remote containment systems provide. While a gravity transfer system is preferable as it is 'passive', where this would require below-ground pipework, the integrity of the pipework can be difficult to monitor compared to an above ground pumped system. These are factors that should be considered in the risk assessment when determining an appropriate containment strategy for a site.

Another, less common, method of providing containment is to surround part, or all, of a site with diaphragm or sheet piling cut-off walls, which extend down to an impermeable stratum. The impermeable stratum acts as an impermeable floor and in the event of an incident pollution is restricted to the ground contained by the cut-off walls. A major disadvantage to this approach is that it may result in a large quantity of contaminated soil for which, ultimately, treatment or disposal arrangements would need to be made and paid for. Also, it is not possible to monitor the integrity of the containment. So, cut-off walls should only be used to provide tertiary protection where other types of secondary containment described in this section are already in place. Further guidance on sacrificial areas and temporary containment is given in Chapter 11.

3.5 COMBINED CONTAINMENT SYSTEMS

A combination of both local and remote systems can be provided on a site incorporating a variety of transfer systems as illustrated by the key plan in the overview of this publication.

Combined containment systems have both local and remote elements and are designed to contain some of the escaped inventory close to the source, as in local containment, and to transfer by gravity, or by pumping, to a further secondary containment facility at a remote location.

For combined systems, the distinctions between secondary and tertiary storage can sometimes blur as shown in Box 3.1.

Box 3.1 Combined containment systems

A combined containment system may provide only limited local containment, in which case it becomes, in effect, a remote system as described above. At the other end of the scale, a combined system may include full secondary containment at source, in which case the additional facility to transfer to remote secondary containment can provide an extra degree of environmental protection. Secondary containment in this situation is therefore tertiary containment.

Transfer arrangements

The release of material from the local bund to the remote containment should be controlled manually (for example, by operatives opening a valve when the bund appears to be in danger of overflowing), however, this introduces vulnerability to human failure as it requires competent staff to be available 24/7 to correctly detect, diagnose and act. Alternatively, an overflow weir may be incorporated into the bund design so that no intervention is required to relieve overfilling. Where the capacity of the bund is less than the recommended capacity for a local system, it is essential that the transfer control mechanism operates reliably and preferably incorporates back-up or fail-safe devices. Failure of the control mechanism, or inadequate capacity of the transfer system, could cause a bund with a limited capacity to overflow.

3.6 SYSTEM SELECTION

The assessment of which type of system (or combination of systems) would be most effective and provide best value for money in a particular situation involves consideration of a wide range of factors. These are summarised in Table 3.1.

Table 3.1 System selection

Issue	Factors to consider
Storage of inventory	<ul style="list-style-type: none"> ■ inventory quantity, rainwater, firefighting agents (foam) plus an allowance for firefighting water if required (see Chapter 4) ■ nature of inventory and any 'cocktails' that may result from an incident where remote secondary containment is shared by a number of different inventories (incompatible substances, water-miscible and water-immiscible substances etc) ■ the nature of the primary system, for example whether single tank, tank farm, process plant, warehouse, pipeline, loading point or drum store.
Receptors	<ul style="list-style-type: none"> ■ the proximity and sensitivity of receptors ■ the level of unmitigated risk to the receptors.
Site constraints	<ul style="list-style-type: none"> ■ space available for containment works ■ the potential for using or adapting existing containment facilities, for example interceptors, lagoons and bunds, and on-site or external treatment plant facilities which may have spare storage or treatment capacity ■ the potential for sharing containment facilities across different process areas of a site where a range of different inventories may be present ■ site topography ■ the type of drainage system, including the method of disposal of trade effluents, sewage and stormwater, and how the drains interconnect ■ future development plans for the site, either physical changes in layout, plant or buildings, or in the processes to be carried out.
Financial	<ul style="list-style-type: none"> ■ cost constraints.

Case study 3.1
Example of process resulting in selection of remote secondary containment, West Yorkshire, UK

PPG Architectural Coatings UK Ltd are a manufacturer of paints with a high inventory of chemicals and finished goods stored on their site at Batley, West Yorkshire. With a change to the CHIP regulations, the site became a top tier CoMAH site after many years of being considered a 'normal' manufacturing establishment and therefore required preparation of a CoMAH safety report to evaluate the offsite potential for pollution in the event of a fire and/or spill.

The potential environmental impact from the fire water runoff to an adjacent stream was assessed as a significant MATTE, so the site had to consider how to mitigate impact.

An initial scheme considered effectively containing the entire sloping site within a bund wall. However, this was discounted on cost grounds and a more economically viable option was developed focusing on the control of runoff via the drainage system to the stream.

Surface water (and potentially firewater) runoff from the former Victorian mill complex drains directly to the stream. However, details of the drainage and potential overland flow paths were unknown and had to be established by a detailed site topographic survey. The initial phase of works installed automatic drain closing penstocks on all the outfalls to the stream. These are triggered by the sound of the site fire alarm and by push-button to allow manual closure. They are powered by the mains with a solar battery back-up.

The topographic survey and assessment of firefighting water volumes confirmed that additional containment volume would be required within the site during an incident. This was achieved by lowering an existing car park adjacent to the stream by some two metres to create a lagoon that was designed to fill via backing up of the site drainage once the outfall had closed.

The walls and base of the lagoon, still retained as a car park, were designed following the original CIRIA R164 guidance to be liquid retaining and hold contaminated firefighting water and surface water runoff until it could be remove for offsite disposal. Part of the site's emergency response plan includes a 24/7/365 contract to provide tankers to remove firefighting water from the lagoon should its capacity be fully used during an incident.



3.7 SITE ZONING

As stated in Chapter 2, where a range of inventories are to be stored on a site, the site hazard rating for each inventory should be considered individually. Where such analysis results in differing ratings for each, or groups of, inventory, it may be appropriate to consider 'zoning' the site as differing classes of containment may be required.

Such an approach is likely to be governed by site (space) and economic constraints.

3.8 SYSTEM RELIABILITY

It is not intended that the reliability of the overall containment strategy discussed in this section should influence the class of the containment system. However, overall system reliability is a matter that should be considered as part of the design of the containment facilities.

If properly designed and constructed, a local, remote or combined system is capable of providing effective secondary and/or tertiary containment. However, the degree of environmental protection provided by each system depends upon its reliability to respond to an incident in the way intended. This level of reliability of a system depends, on a number of factors including:

- complexity – the more there is to go wrong, the greater the risk
- whether intervention (manual or automatic) is necessary for the system to work
- ease of maintenance
- ease with which containment condition or integrity may be monitored and any defects or failures dealt with
- site management (arrangements for ongoing assurance, staffing competence, safety culture etc).

It is important to stress that this reliability rating is a relative measure of the likelihood that the containment system will perform as it was designed to, throughout the whole of its life, when called into action.

It is evident that system reliability is dependent not only on the intrinsic characteristics of the system but also on the circumstances in which it is used. It should be stressed that Table 3.2 necessarily simplifies what is a complex design process and there may be site factors or particular characteristics of the operation that would lead to different conclusions regarding relative reliability.

The design of secondary containment systems should therefore balance the advantages and disadvantages of particular features and characteristics of a system. This will require a full and thorough understanding of the site and operations likely to be carried out on it

Table 3.2 Reliability of containment systems

Type of system	Summary of system characteristics				Suggested relative reliability
	Complexity	Intervention	Maintenance	Monitoring	
Local	<ul style="list-style-type: none"> simplest system fully passive does not rely on operation of valves, transfer systems etc. 	<ul style="list-style-type: none"> no intervention required in response to an incident intervention necessary only to ensure bund kept free from accumulated rainwater and to empty following incident. 	<ul style="list-style-type: none"> relatively easy all parts accessible no valves, pumps, transfer systems etc to maintain. 	<ul style="list-style-type: none"> relatively easy major defects obvious leakage from primary containment into bund easy to detect. 	High
Remote	<ul style="list-style-type: none"> system has more components, ie local catchment area, transfer system and remote containment additional components with pumped transfer system. 	<ul style="list-style-type: none"> none required with gravity transfer system non-automatic pumped transfer systems require intervention at start of incident intervention necessary only to ensure bund kept free from accumulated rainwater and to empty following incident, or during incident to reduce level if capacity to be exceeded (eg by transferring our firewater). 	<ul style="list-style-type: none"> relatively difficult systems more 'extensive', likely to include inaccessible transfer system on pumped system, valves, pumps etc require maintenance. 	<ul style="list-style-type: none"> less easy since three potential leakage areas to monitor: catchment area, transfer system and remote containment transfer system particularly difficult. 	Low: except where transfer system gravity operated, or pumped above ground system, in which case medium
Combined	<ul style="list-style-type: none"> same as remote system. 	<ul style="list-style-type: none"> same as remote system but need also to ensure any banded area free from accumulated rainwater. 	<ul style="list-style-type: none"> same as remote. 	<ul style="list-style-type: none"> same as remote. 	Low or medium, with same caveats as remote systems

4 Containment system capacity

This chapter provides:

- An introduction to determining containment capacity (Section 4.1)
- A review of current industry practice (Section 4.2)
- A method for assessing containment capacity (Section 4.3)
- A review of research into the freeboard in bunds to allow for dynamic effects (Section 4.4)
- A summary of retention capacity recommendations (Section 4.5)

4.1 INTRODUCTION

Determining the correct capacity for a containment system is one of the most important parts of the design process. If the capacity of a system is too large, resources that might have been invested in other ways may have been wasted, whereas if a system is too small and is incapable of providing effective protection in the event of an incident, the cost of installation may equally have been wasted.

The assessment of capacity raises a number of issues, such as:

- how much firefighting water would be likely to be used in the event of a major fire
- the impact of any 'burn strategies' that may be in place
- whether firefighting water can be recirculated.

It is important to consult widely with the regulatory authorities and in particular the Fire and Rescue Service, to ensure that the containment system is designed based on credible scenarios.

The method in this guidance is applicable to all types and sizes of containment system from the storage of IBCs in a warehouse to large tank farm sites. However, it is important to note that for the storage of certain materials, there are specific regulations that apply and these must be adhered to. These are referred to in Section 1.7.

As a general point, where containment capacity could potentially be exceeded, operators should have a clear understanding of what would happen to the inventory, ie where it will go, and have contingencies in place to minimise the risks. This will have been established by the assessment of the pathways completed as part of the site risk rating described in Chapter 2.

4.2 CURRENT INDUSTRY PRACTICE

Table 4.1 lists the current approaches, regulations and guidelines for estimating secondary containment volumes and are reviewed in the sections that follow. They are also summarised in Table 4.2.

Table 4.1 List of approaches, regulations and guidelines

Guidance	Section
The '110%' and '25%' rules	4.2.1
The Control of Pollution (Oil Storage) (England) Regulations (OSR) 2001	4.2.2
Health and Safety Executive guidance: <ul style="list-style-type: none"> ■ HSG51 (1998a) <i>The storage of flammable liquids in containers</i> ■ HSG176 (1998b) <i>The storage of flammable liquids in tanks</i> ■ HSG71 (2009b) <i>Chemical warehousing, the storage of packaged dangerous substances</i> ■ HSE (2009a) <i>Safety and environmental standards for fuel storage sites, Process Safety Leadership Group (PSLG), Final report</i> ■ The Control of Major Accident Hazard (COMAH) Regulations 1999 ■ COMAH (2008) <i>Competent Authority policy on containment of bulk hazardous liquids at COMAH establishments</i> 	4.2.3
Pollution prevention guidelines (PPG) <ul style="list-style-type: none"> ■ PPG18 (2000) <i>Managing fire water and major spillages</i> ■ PPG26 (2004) <i>Storage and handling of drums and intermediate bulk containers</i> 	4.2.4
Environmental Permitting Regulations (England and Wales) 2010 (ERP)	4.2.5
Energy Institute (EI) <ul style="list-style-type: none"> ■ EI (2012) <i>Model code of safe practice. Part 19: Fire precautions at petroleum refineries and bulk storage installations</i> ■ EI (2013) <i>Model code of safe practice. Part 2: Design, construction and operation of petroleum distribution installations</i> 	4.2.6
BASIS Registration Scheme	4.2.7
Summary of the requirements of each of the regulations or guides listed here	4.2.8

4.2.1 The '110 per cent' and '25 per cent' rules

The basis for much industry practice in the past has been the 110 per cent and 25 per cent rule. Although not following the risk-based approach recommended in this guide, this practice has been in use for many years.

Where a single bulk liquid tank is banded, the recommended minimum bund capacity is 110 per cent of the capacity of the tank.

Where two or more tanks are installed within the same bund, the recommended capacity of the bund is the greater of:

- 1 110 per cent of the capacity of the largest tank within the bund.
- 2 25 per cent of the total capacity of all of the tanks within the bund, except where tanks are hydraulically linked in which case they should be treated as if they were a single tank

The existing 110 per cent recommendation for single tanks and hydraulically linked multi-tank installations implies a margin of 10 per cent, which is discussed as follows. The recommendation for other multi-tank installations, the 25 per cent rule, is based on the assumption that it is unlikely that more than one tank will fail at any one time. This may be reasonable in circumstances where the contents escape from a primary tank as a result of, for example, tank corrosion or operator error, which is likely to affect only one tank at any one time. However, there may be credible scenarios such as fire or explosion or acts of vandalism that could affect all of the tanks within a banded area.

The 10 per cent margin has been interpreted by industry and regulators to cover a range of factors including:

- prevention of overtopping of the bund in the event of a surge of liquid caused by the catastrophic failure of the primary tank
- prevention of overtopping, which may be caused by wind-induced wave action during the time that the bund is full following failure of a primary tank

- an allowance for firefighting agents, including a foam blanket on the surface or firefighting water
- protection against overfilling
- an allowance for rain that might collect in the bund and reduce its net capacity, or for rain that might fall in coincident with, or immediately following, the failure of the primary containment.

The method set out in this guidance (Section 4.3) provides a quantitative assessment of these assumptions, rather than relying on an arbitrary allowance of 10 per cent of the primary capacity or 25 per cent of the primary capacity for multiple tanks within a common secondary containment. See Sections 4.3 and 4.4 which cover credible scenarios.

It should be noted that the 110 per cent and 25 per cent rules apply as the recommended minimum volume for IBC/drum stores as set out in PPG26, although recent guidance is moving towards the requirement to size IBC/drum stores (and associated combined containment system) based on containment of complete inventory plus rainfall and firefighting water, eg in accordance with HSE (2009b) and EI (2013). The guidance contained in HSE (2009b) and PPG26 is discussed in Sections 4.2.3 and 4.2.4 respectively.

4.2.2 The Control of Pollution (Oil Storage) (England) Regulations (OSR) 2001

The OSR apply to the storage of oil in containers in quantities of greater than 200 litres except where it is stored within a building, is at a private dwelling (where the limit is increased to 3500 litres) or is on a premise use for refining oil or for the onward distribution of oil to other places.

Section 3(2) of the OSR requires that secondary containment is provided with a minimum of 110 per cent of the container's capacity for a single container or where there is more than one container, not less than 110 per cent of the largest container or 25 per cent of their aggregate capacity, whichever is the greater.

Further advice on the interpretation of the OSR is provided by EA *et al* (2011a).

4.2.3 Health and Safety Executive (HSE)

HSG51 The storage of flammable liquids in containers

HSG51 applies to containers with a volume of less than 1000 litres and recommends that secondary containment equivalent to 110 per cent of the largest containers is provided for both indoor and outdoor storage of flammable materials.

HSG71 Chemical warehousing, the storage of packaged dangerous substances

HSG71 recommends that spillage control in outdoor areas should comprise a containment area with a volume that is at least 110 per cent of the capacity of the largest single container except in the case of oil storage where 25 per cent of the total volume should be provided. The guidance also makes reference to CIRIA R164 and PPG18 for further advice on containment capacities.

HSG176 The storage of flammable liquids in tanks

HSG176 applies to above and below-ground bulk fixed bulk storage tanks and to portable, or skid mounted, vessels with a capacity greater than 1000 litres. Smaller containers are covered by HSG51.

The guidance recommends that the secondary containment should have sufficient capacity to contain the largest predictable spillage and that a bund capacity of 110 per cent of the capacity of the largest storage vessel located within the bund will normally be sufficient. It also advises that smaller capacity bunds may be acceptable where liquid can be directed to a remote or tertiary containment area.

It is stated that individual bunding is to be preferred to common bunding, particularly for large tanks,

but where several tanks are contained in one bunded area, intermediate lower bund walls should be provided to divide tanks into groups to contain small spillages and to minimise the surface area of any spillage. The total capacity of tanks in a bund should not exceed 60 000 m³ (120 000 m³ for floating-roof tanks).

Where there is no risk of pollution or of hazard to the public the guidance advised that the containment volume can be reduced to no less than 75 per cent of the largest vessel located within the bund.

COMAH Competent Authority policy on containment of bulk hazardous liquids at COMAH establishments. Control of Major Accident Hazard (COMAH) Regulations 1999

If the quantity of dangerous substances on site exceeds the qualifying inventory for COMAH, operators of such sites are required to take all measures necessary to prevent major accidents based on the principle of reducing risk to ALARP.

CA (2008a) requires that secondary containment shall:

“...have sufficient capacity to allow for tank failure and firewater management. This will normally be a minimum capacity of either 110 per cent of the capacity of the largest tank, or 25 per cent of the total capacity of all the tanks within the bund, whichever is the greater”

and at Part C 11 states that:

“The installation shall have sufficient capacity to hold safely the anticipated or foreseeable volume of hazardous liquids, including firewater, compatible with the intended operational characteristics.”

Safety and environmental standards for fuel storage sites, Process Safety Leadership Group (PSLG), final report

The final report was published to translate the lessons learnt following the catastrophic Buncefield incident into effective and practical guidance for the industry. Part 4 of the report provides guidance on engineering against the loss of containment principally from large gasoline tanks and states that:

“The bund should be sized for 110% of the ‘tank rated capacity’ (TRC) as a minimum. This assumes that the minimum standards for overfill protection systems of control are in place relating to:

- *tank levels and capacities are determined in accordance with Appendix 3 Guidance on defining tank capacity (to the PSLG Final report);*
- *position and type of level gauges and high level detectors;*
- *how are these monitored and the required response;*
- *response times to shutdown inflow*

Unless multiple tanks sharing the same bund are hydraulically linked, simultaneous overfill of independent tanks can be discounted as a realistic hazard. Therefore, the 25% criteria would not apply to the Overfill level. For the bund capacity calculation based on 25% of the total capacity of all the tanks, the normal fill levels of all the tanks within the bund should be used.

The 25% criterion applies to the risk of loss of containment of more than one tank and provision for firewater management. This provides a buffer to deal with the incident and informs risk assessment as to the degree of tertiary containment that may be required to deal with subsequent failure of secondary containment in a severe and prolonged event. The actual sizing for multi-tank bunds will be determined by the hazard and the risk – including the modifying factors stated above.”

4.2.4 Pollution prevention guidelines (PPG)

PPG18 Managing fire water and major spillages

PPG18 (EA, NIEA, SEPA, 2000) provides advice on managing firewater and major spillages. For advice on local secondary containment capacity, PPG2 (EA, NIEA, SEPA, 2011a) is referred to, ie the '110 per cent' and '25 per cent' rules. However, for remote containment the advice mirrors that in this guidance with no distinction made between secondary and tertiary containment.

PPG26 Storage and handling of drums and intermediate bulk containers

PPG26 (EA, NIEA, SEPA, 2004) applies to IBCs of not more than 1000 litres capacity that are not directly connected to a part of a process or other point of use, irrespective of the number of containers stored.

The guidance states that the capacity of secondary containment facilities should take account of the maximum volume of product that could be stored at any one time. If a fixed firefighting system is in place, additional provision will be required for the quantity of firefighting media (eg foam) likely to be used.

For multiple container storage, containment facilities should have sufficient capacity to contain at least 25 per cent of the total volume of the containers being stored, or 110 per cent of the largest container, whichever is the greater.

With large external stores, 25 per cent containment capacity may result in low containment walls, which are quickly overwhelmed by rainfall or firefighting agents. An additional 100 mm height on the walls, known as freeboard, should be provided.

Where containers are stored inside a building, containment facilities should be proportionate to the risk, however, the risk may be substantial. For example, in the case of agricultural stores (see Section 4.2.7) the capacity should be between 110 per cent and 185 per cent of the maximum storage capacity.

4.2.5 Environmental Permitting Regulations (England and Wales) (EPR) 2010

The EPR recognises the potential harm that can be caused by accidental releases from tanks, sumps and containers and a condition of the permit will be the provision of secondary containment or other appropriate measures to prevent or minimise leakage from the primary container.

No specific recommendation are made on containment capacities, however, where there is potential for significant pollution to occur an emissions management plan is required informed by an environmental risk assessment. The outcome of the risk assessment determines the containment or other measures that may be required.

4.2.6 Energy Institute (EI)

EI (2013) and EI (2012b) refer to the CA containment policy for COMAH sites for advice on the provision of secondary containment (CA, 2008b).

4.2.7 BASIS recommendations

Defra (1998) recommends that stores should be capable of containing 110 per cent of the total amount of pesticides to be stored at any one time. However, this should be increased to 185 per cent in "pollution risk or environmentally sensitive areas".

4.2.8 Summary

Table 4.2 Summary of secondary containment requirements in regulations, policies, schemes and publications

Regulations/guidance	Containment requirements	Scope	Typical inventory
OSR 2001 PPG2	110% of the capacity for a single container or, where there is more than one container, not less than 110% of the largest container or 25% of their aggregate capacity, whichever is the greater.	Greater than 200 litres or 3500 litres when stored on residential premises or within a building.	Oil
COMAH	Take all measures necessary to prevent major accidents based on the principle of reducing risk to ALARP.	Qualifying inventory for COMAH.	Dangerous substances
CA containment policy for fuels	Sufficient capacity to allow for tank failure and firewater management. This will normally be a minimum capacity of either 110% of the capacity of the largest tank, or 25% of the total capacity of all the tanks within the bund, whichever is the greater.		
HSE (2009a)	110% of the 'tank rated capacity' (TRC) as a minimum provide that minimum standards for overfill protection systems of control are in place. For the bund capacity calculation based on 25% of the total capacity of all the tanks, the normal fill levels of all the tanks within the bund should be used.		
HSE (1998a)	110% of the largest containers are provided for both indoor and outdoor storage.	Less than 1000 litres.	Flammable liquids in containers
HSE (1998b)	Should contain the largest predictable spillage and that 110% of the capacity of the largest storage vessel located within the bund will normally be sufficient. Advises that smaller capacity bunds may be acceptable where liquid can be directed to a remote or tertiary containment area.	Greater than 1000 litres.	Flammable liquids in tanks
HSE (2009b) PPG26	In outdoor areas at least 110% of the capacity of the largest single. For multiple container storage at least 25% of the total volume of the containers being stored, or 110% of the largest container, whichever is the greater. Allowance for firefighting waters should be made. Containment should be based on risk assessment.		Packaged dangerous substances
EI (2012b)	Refers to CA containment policy for advice on appropriate secondary containment volumes.		Petroleum
BASIS Registration Scheme	110% of the total amount of pesticides to be stored at any one time. However, increased to 185% in "pollution risk or environmentally sensitive areas".		Pesticides for use in agriculture, horticulture and forestry

4.3 METHOD FOR ASSESSING CONTAINMENT CAPACITY

4.3.1 Introduction

This section sets out a method for assessing the required site-wide capacity for containment. This refers to and draws on experience in using a range of the current approaches discussed in Section 4.2.

The method is based on the principle that the containment should be capable of retaining:

- the total volume of inventory that could be released during a credible incident (see Section 4.3.2)
- the maximum rainfall that would be likely to accumulate within the containment before, during and/or after an incident (see Section 4.3.3)
- firefighting agents (water and/or foam), including cooling water (see Sections 4.3.4).

A summary of recommendations from these approaches is provided in Section 4.5 and Table 4.6.

4.3.2 Volume of inventory

The volume of inventory should be taken as the capacity of the primary containment.

For above ground storage tanks, the brimful capacity of the primary containment should normally be adopted as advised in the environmental permit. However, where the tank is fitted with a physical overflow, the capacity at which the tanks would overflow may be taken.

In some cases, and subject to a risk assessment, it may be appropriate to use the nominal capacity, or TRC. This should be discussed and agreed with regulators at an early stage in the design process and would normally only be allowable if a high integrity overfill protection system is in place.

The relationship between capacities is shown in Figure 4.1.

In determining containment requirements, the volume of substance should be based on the loss from a credible scenario and this need not necessarily involve the entire site inventory. This should also be discussed and agreed with regulators at an early stage in the design process.

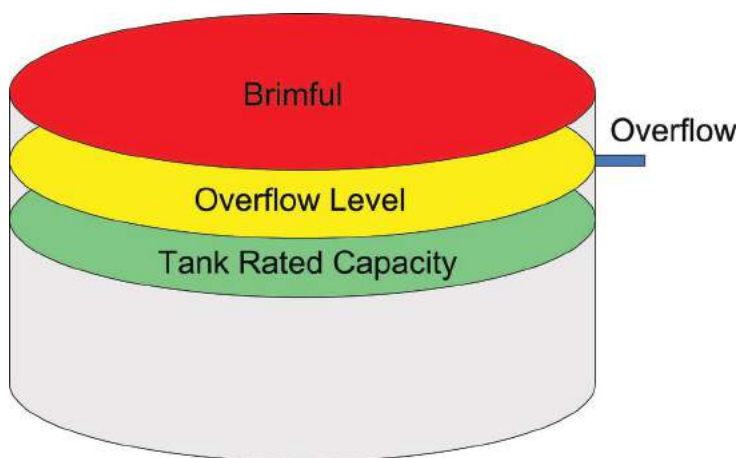

Figure 4.1 Definition of tank capacities

4.3.3 Rainfall

The following recommendation is based on the assumption that secondary containment is regularly inspected and that any rainwater that has collected is removed regularly. If this is not the case, capacity should be increased to allow for the accumulation of rainwater between inspections and/or the time between its periodic removal.

If the containment is covered, or located within a building, then it is less important to account for accumulated rainfall when determining the containment capacity although collapse of the roof during the incident is a possibility.

The allowance for accumulated rainfall should be based on an event (storm) with an annual exceedance probability (AEP) of 10 per cent (1 in 10). This is commonly referred to as the 1 in 10 year return period event.

The containment capacity should allow for rain falling over the containment area immediately preceding an incident (ie before it could be removed as part of routine operations) and immediately after an incident (ie before a substance, which had escaped from the primary, could be removed from the bund).

The containment volume should include an allowance for the total volume of accumulated rainfall in response to a 10 per cent AEP event for:

- a 24-hour period preceding an incident
- the duration of the incident (advice on the duration should be sought from the Fire and Rescue Service)
- an eight day period following an incident or other time period as dictated by site specific assessment.

The preferred method of estimating the rainfall depths is to use the depth-duration-frequency rainfall model contained on the *Flood Estimation Handbook* (FEH) CD-ROM (CEH, 2000), which provides location specific rainfall totals for given durations and return periods.

However, as a first estimate, it may be appropriate to refer to Figure 4.2, which provides average annual rainfall depths and those for the 24-hour and eight day 10 per cent AEP events.

Care should be taken to include any additional areas that might drain into the containment system (local, remote or combined) when making an allowance for rainfall depth in the capacity assessment.

Where rainfall, or the management of rainfall, is likely to present a significant problem, providing a roof over the containment should be considered.

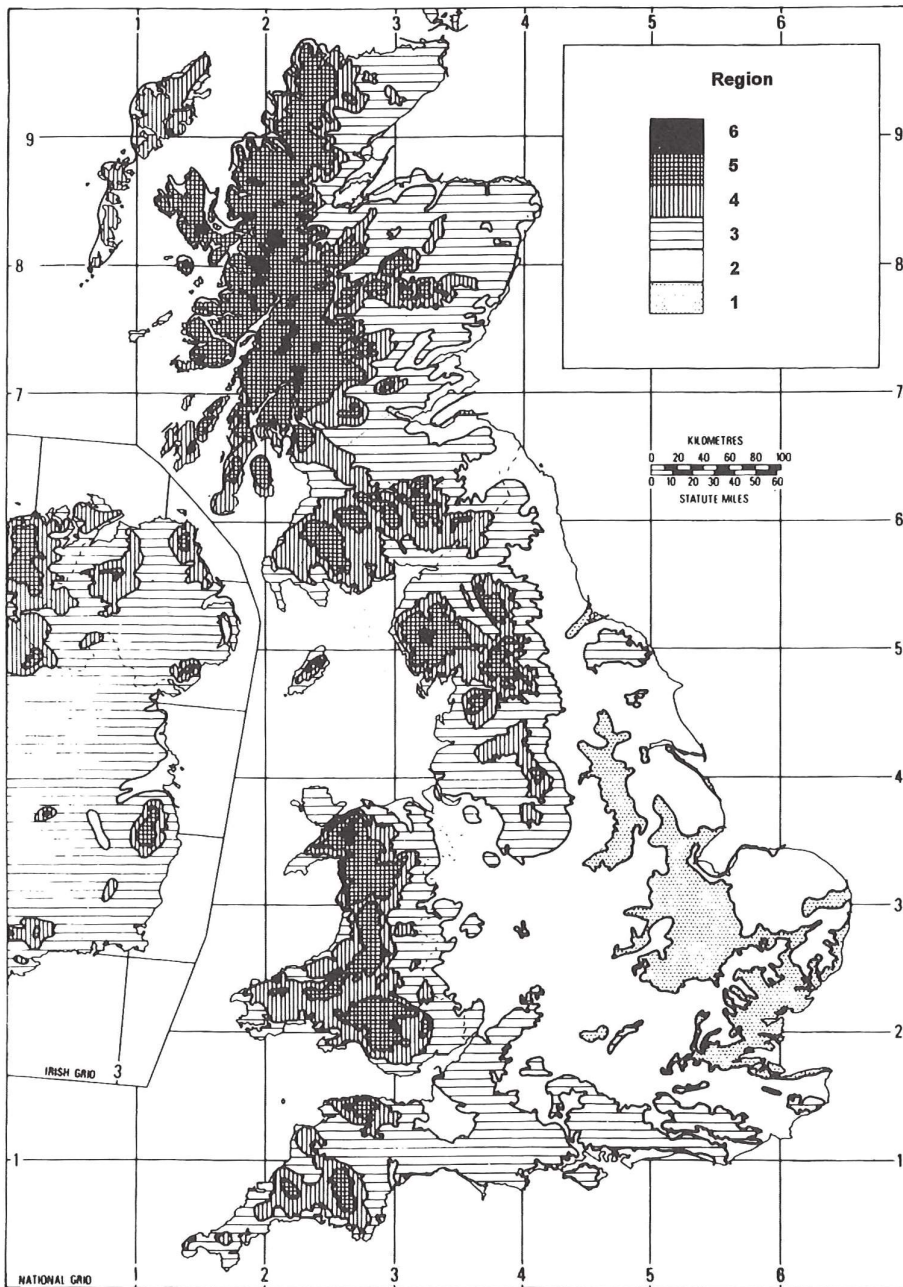

Region	Standard annual average rainfall (mm)	Rainfall depth (mm) 10-year return period	
		24-hr duration	8-day duration
1	<600	29	54
2	600-800	32	65
3	800-1200	41	95
4	1200-1600	52	120
5	1600-3200	88	231
6	3200	106	288

Notes

It should be stressed that Figure 4.2 should only be used to derive a first estimate for considering containment volumes. This is for two reasons:

- 1 The figure is based on *Flood studies report* (Institute of Hydrology, 1975) data produced up to 1986.
- 2 Climate change effects since the publication of HR Wallingford (1986) will have resulted in different annual rainfall figures. Detailed design should therefore be based on the output of the FEH rainfall.

Figure 4.2 Average rainfall depths (from HR Wallingford, 1986)

4.3.4 Firefighting water and firefighting agents

This section provides:

- An introduction to firefighting water and firefighting agents (Section 4.3.4.1)
- Advice on the allowance to be made for firefighting water in the design of remote and combined systems (Section 4.3.4.2)
- Advice on delivery rates (Section 4.3.4.3)
- A review of ISO/TR 26368:2012 (Section 4.3.4.4)
- Advice on fixed firefighting systems (sprinklers) (Section 4.3.4.5)
- Reviews guidance by Local Government Association and Water UK (2007) (Section 4.3.4.6)
- Methodology for forecasting the volume of firefighting water (Section 4.3.4.7)

4.3.4.1 Introduction

It is difficult to provide general recommendations for capacity allowance for firefighting water as much depends on the nature of the site and the manner of response to an incident. However, since many incidents are likely to involve fire, and almost all 'worst case' scenarios involve fire, making adequate provision for retention or recycling of firefighting and cooling water is of critical importance.

Firefighting agents, including water-based foams, are accounted for in the estimation of containment capacity by making an adequate allowance in the design of the height of the wall (freeboard). The amount of freeboard required for firefighting foam should be agreed with the Fire and Rescue Service or occupational fire brigades but the amount should be no less than 100 mm.

In making recommendations, a distinction has to be made between local (bund) and remote or combined containment in terms of what is practicable.

It would normally be impracticable to design the local containment with sufficient capacity to contain the quantities of firefighting and cooling water that would be used in a major fire.

In practice, in the event of a major fire, cooling water would be sprayed on to any threatened primary container, either through hoses, monitors, or a fixed sprinkler or deluge system, or both. As a consequence, the bund could be partly or totally filled with cooling water leaving insufficient or no residual capacity to cope with any release of substance if the primary containment subsequently failed. In this situation the Fire and Rescue Service should be consulted and one of the following options agreed:

- procedures for recycling cooling water so that there would be no build-up in the bund. This would require the incorporation in the design of suitable facilities such as the provision of suitable pick-up sumps/transfer systems. (It should be noted that some stored inventories, eg fatty acid methyl esters (FAME) and ethanol, dissolve and emulsify in water and may not be suitable for recirculation as firewater).
- the maximum amount of cooling water that would be likely to be used in the worst case scenario, and increasing the capacity of the bund accordingly. Where cooling water is supplied through fixed installations, the maximum possible application will equal the capacity of the supply reservoir (although it may be replenished during an incident). Such installations are normally designed for a water delivery rate in the range of 2 to 20 l min⁻¹m². Where cooling water is applied by hose, perhaps to supplement the fixed installation, assessment of the volume should necessarily rely on assumptions about application rate and duration. As discussed above, in many situations it may be impracticable to provide the additional capacity.

In many cases this latter option would require the local containment to be several times larger than that required simply by the capacity of the primary containment. On most sites this could translate into very much higher bund walls that could then cause construction, operational and safety problems, and hinder the ability to fight fires.

In many instances, where fire is a credible scenario, local containment of firewater is unlikely to be a feasible option and therefore either tertiary containment, or for larger sites, remote secondary containment will be necessary. For local containment, other than the freeboard to retain a blanket of foam, no separate allowance above the height of the bund wall to contain the volume of substance (see Section 3.3.1) and the accumulated rainwater (see Section 3.3.2) will be required.

4.3.4.2 Allowance for firefighting water in the design of remote and combined systems

Remote and combined systems should have sufficient capacity to manage such firefighting and cooling water as could reasonably be expected to be used in a major fire. It is essential to consult fully with the Fire and Rescue Service to arrive at a reasonable volume estimate, taking into account the following:

- 1 The size and layout of the plant.
- 2 The nature of the materials present and the processes carried out.
- 3 The fire detection and response systems (eg fixed sprinkler installations, on-site firefighting capability) on (or proposed for) the site.
- 4 The Fire and Rescue Service's contingency strategy for dealing with an incident.
- 5 The Fire and Rescue Service's own delivery capability including the number and type of appliances that could respond to an incident.

It should be stressed that a credible scenario should be considered where perhaps the fixed sprinklers fail and the incident is dealt with by mobile deployment. It will therefore be important to discuss with the Fire and Rescue Service what their actual response might be to an incident over and above their planned first response. Regulators are increasingly asking COMAH establishments to produce firefighting plans as part of their emergency response measures. The failure to manage the firefighting water was one of the causes of the environmental harm that resulted from the Buncefield incident.

Based on these factors, and in consultation with the regulators and the plant operators, an appropriate capacity of containment can be determined.

On high or medium hazard rating sites (see Chapter 2) sufficient capacity should be provided to contain and/or manage all of the firefighting and cooling water that could reasonably result from a credible worst case scenario fire.



Where this would not be possible because of physical constraints, or where it would be difficult operationally, it will be necessary to review with the Fire and Rescue Service ways of reducing the anticipated quantities of firefighting and cooling water to a level that could be contained. This may involve, for example, one or a combination of the following measures:

- reduce the volume of the primary containment
- install or provided additional fixed fire sprinklers, monitors and detection systems
- compartmentalising the plant or site to limit the propagation of a fire
- recycling the firewater where this would not be hazardous (ie FAME, ethanol etc)
- using additional temporary pollution prevention measures deployed as part of an incident response plan (IRP) agreed in advance with the regulators. Advice on preparing an IRP and appropriate temporary pollution prevention measures are given in PPG21 (EA, NIEA, SEPA, 2009) and PPG18 (EA, NIEA, SEPA, 2000) respectively
- gaining the agreement of the Fire and Rescue Service, the regulators and the operators to a 'controlled burn' response strategy. Controlled burns are used to prevent or reduce water and air pollution from firefighting activities at industrial and commercial sites. However, these are only appropriate in very specific cases. Advice on controlled burn strategies is provided in PPG28 (EA, NIEA, SEPA, 2007)
- providing a means of removing contaminated firefighting water during an incident such as discharge to the foul sewer (with appropriate consent) or transporting to a suitable reception facility by road tanker.

For sites with a low hazard or risk rating it will be harder to justify the costs of full containment for firefighting and cooling water and in consultation with the Fire and Rescue Service, the regulators and the site operators, a balance should be struck between protection and cost. However, there are some facilities, for example those that fall within the scope of the OSR, for which a prescribed minimum containment volume is mandatory.

The volume of firefighting and cooling water released at a site during an incident may be limited by one or all of:

- the capacity of the fixed water delivery installations on the site (eg sprinklers, deluge systems, ring mains supplied by on-site storage tanks)
- the delivery capability of the fire brigade using tendered or pumped-in water
- the maximum quantity that can be delivered by fixed installations (ie the capacity of the delivery storage tanks or reservoirs, with due allowance for replenishment rate through, for example, water company mains).

By contrast, the delivery capability through fire brigade hoses if connected to the water company mains, or extracting from a watercourse, may be effectively unlimited so that the quantity of firefighting and cooling water delivered would depend solely on the demands of the incident.

4.3.4.3 Delivery rates

Table 4.3 provides an indication of water delivery rates from fire hydrants and fire tenders. To estimate the quantity of firefighting and/or cooling water that might be used during an incident, an inventory of fire hydrants on, or in vicinity of the site, should be completed that includes the potential delivery rates and supply capacity (ie it is connected to a public mains supply (or supplies), or fed from a storage tank with a fixed capacity).

There are a number of high hazard installations located on estuaries and in Port Authority areas. The Port Authorities have a responsibility to have equipment available for timely use in major emergencies and may include one or more fire tugs. Each tug is likely to have a water pumping capacity of the order of 2400 m³h⁻¹ (40 000 l min⁻¹)

Discussions with the Fire and Rescue Service will be required to determine the number and type of appliances that would be mobilised to site in response to an incident. They should also establish what their actual response might be to an incident over and above their planned first response.

Table 4.3 Typical water delivery rates for hydrants, hoses and fire tenders

Delivery appliance	Flow rate (litres/min)	Delivery capacity (litres)	Head (m)
Fire hydrant	>550 (delivery rate at hydrant)	Dependent on supply storage	>3
Hose (25 mm)	24	Dependent on supply storage	>4
Fire tender (average) 24 mm nozzle	Dependent on number of hoses	1200 to 2000	Up to 50
Fire tender (large) 24 mm nozzle	Dependent on number of hoses	Up to 4500	Up to 50

Further useful advice on application rates for firefighting media is provided at Annex D of EI (2012b).

4.3.4.4 ISO/TR 26368:2012 Environmental damage limitation from fire-fighting water runoff

Current guidance on the approach to calculating firefighting and cooling water volumes is given in ISO ISO/TR 26368:2012.

ISO/TR 26368:2012 provides advice on risk reduction strategies that are consistent with this guidance and methods to assess the volume of contaminated firewater that may be generated in response to an incident. The recommendations are only summarised here and reference should be made to the report for detailed guidance on the methods presented.

Volumes are determined for the following as a basis for calculating the maximum required retention volume for firefighting water:

- 1 The total volume of water likely to be used to fight the fire.
- 2 The containment volume provided for each separate contained area of the site (there may only be one).
- 3 The estimated total volume of contaminated firefighting water based on the largest volumes estimated at point 2.
- 4 The expected volume of rainfall.
- 5 The total required retention volume for contaminated fire water (points 3 and 4).

The largest volume calculated at point 2 is then selected as the initial estimate of the volume of contaminated fire water and an estimate is then compared with the fire water likely to be used for the site (point 1). The larger of the two volumes is selected as the required retention volume for contaminated fire water.

This pragmatic methodology requires some clarification:

- the potentially 'partial site' volume estimated at point 2 assumes that the incident can be contained within that part of the site. The risk of a localised incident spreading to other parts of a larger site should be considered as part of the risk assessment and discussed with the Fire and Rescue Service and the regulator
- no explicit mention is made in point 2 allowing for the complete failure of the primary containment during the incident. Estimating the local secondary containment volume available for firefighting water should assume a credible scenario that might include the complete failure of the primary containment.

ISO/TR 26368:2012 provides a number of suggested methods for determining the total volume water used to fight a fire:

- defining retention volumes by 'magic numbers' ('Sandoz' and 'Ciba' methods)
- estimating firefighting volumes by model curves
- a risk-based approach
- the 'VCI' methods
- ICI's guidelines for fires involving whole chemical plants.

These are discussed in Box 4.1.

Defining retention volumes by 'magic numbers' ('Sandoz' and 'Ciba' methods)

This deterministic approach is based on feedback from specific incidents and based on tabulated values. In general, the retention volume required ranges from between 3 m³ to 5 m³ per ton of material stored depending on the:

- stored quantity of flammable materials, to define size of compartment
- hazard categories of stored products
- expected fire duration.

This method has the advantage that it is simple to apply and requires little input data. However, the magic numbers are based on only a few case studies and are therefore difficult to extend to every potential fire scenario.

Estimating firefighting volumes by model curves

Water flow rates required by fire and rescue services to extinguish fires have been statistically analysed against the fire area for both small and large fires. It should be noted that there is a significant variability in the results of the analysis. However, relationships have been developed that, when combined with an estimate of fire duration, can provide an indication of the volume of water required to extinguish fires.

If adopting this method, the Fire and Rescue Service should be consulted to agree credible potential fire duration (see Section 4.3.4.2).

A risk-based approach

Reference is made in ISO/TR 26368:2012 to a risk-based approach (the 'Australian Method') for determining the required retention capacity for firefighting water that is similar in scope to this guidance. However, this approach should not be adopted in preference to that set out in this guidance.

The 'VCI' methods

The VCI guidelines presents a method for calculating the quantities of water required for fixed sprinkler systems for chemical warehouses and the containment of runoff water in the event of a fire. However, the calculation of delivery rates and volumes from sprinklers should be based on the method described in the following sub-section.

To ensure that the analysis reflects actual installed systems, the estimation of potentially contaminated water generated by a sprinkler system should be based on BS EN 12845:2009 (although for older systems it might be appropriate to refer to standards that prevailed at the time of installation such as the now superseded BS 5306-2:1990).

Analysis based on BS EN 12845:2003 is discussed in Section 4.3.4.5.

ICI's guidelines for fires involving whole chemical plants

ICI no longer exist as a corporate entity. However, they produced guidance (ICI, 1986) for internal use, on the demand flow rate and duration for fires at chemical plants, which has been widely used. The forecast of the total amount of firefighting water that might be used in the event of a fire affecting the whole of a chemical plant (as distinct from just a discrete area or fire compartment, assumed in the preceding approaches) is shown in Table 4.4.

Table 4.4 Forecast of firefighting water needed to tackle major chemical plant fires (courtesy ICI)

Plant hazard rating ¹	Firefighting water demand
High severity	Total demand 1620–3240 m ³ /hr for four hours
Medium severity	Total demand 1080–1620 m ³ /hr for four hours
Low severity	Total demand 540–1080 m ³ /hr for four hours

Notes¹

High severity includes plants with:

- over 500 tonnes of flammable liquid above its flashpoint
- over 50 tones LPG above its boiling point and over 50 bars
- over 100 tonnes combustible solid with ready flame propagation
- other factors what increase severity

Medium severity covers plants that fall between high and low severity ratings.

Low severity includes plants with:

- less than 5 tonnes flammable liquids above or below flashpoint
- less than 100 kg flammable gas under 1 bar or a flash liquid
- less than 5 tonnes readily combustible solid
- other factors that decrease severity

A summary of the methods presented in ISO/TR 26368:2012 is provided in Table 4.5.

Criteria		Method				
		Sandoz method	Ciba method	ICI method	VCI method	Australian method
Method definition type		Deterministic	Deterministic	Deterministic	Deterministic	Probabilistic (risk-based approach)
Sizing parameters		0 m ³ to 5 m ³ per ton of material (tabulated)	3 m ³ to 5 m ³ per ton of material	Only estimation of expected water flows according to fire risk severity	Tables (general case) plus specific tables for high-rise storages	Rainwater flow, firewater flow for typical fire scenarios
General size of basins		Maximum 1600 m ³	From 700 m ³ to 5000 m ³ , from standard curves	None defined	Tabulated	Two cases: 1 Sizing of a new facility. 2 Evaluation of existing capacity.
Input parameters	Risk classification			Two categories of fire severity: Weak risk: 240 m ³ /h to 1000 m ³ /h for four hours High risk: 1620 m ³ /h to 3240 m ³ /h for four hours	Specific 'Ki' rating	Input parameters according to two logigrams explaining methodologies pertaining to case (1) design and assessment of new water basins, and case (2) evaluation of pertinence of existing water basin
	Hazard category of substances	15 categories			Specific classification of goods	
	Possible fire size	Limited to compartment size	Limited by the largest compartment (max 3000 m ³)		Limited to compartment size	
	Possible fire duration		1h for 200 m ² to 5h for 1200 m ²			
Additional measures	Use of sprinklers	Influence of basin volume only for pharmaceutical goods	Considered in storage limitation and in sizing			A fire safety study is part of the methodology and may lead to the consideration of additional measures
	Limitation of combustible materials	Limited to compartment size	Limited to 250t or 600 m ² if no sprinkler		Limited according to fire hazard	
	Detection and alarm systems					
	Additional feature		Consider water consumption for cooling		Consider water consumption for cooling	

4.3.4.5 Fixed firefighting systems

BS EN 12845:2004+A2:2009 sets out the minimum requirements for the design, installation and maintenance of fixed fire sprinklers in buildings and industrial plants. Section 6 of the standard defines hazard classes depending on the combustibility of the materials stored and their fire load. Maximum storage heights of material are also specified depending on the method of storage. Hazard classes for a number of common stored materials are provided in Annex A to the standard.

Tables 3, 4 and 5 of the standard specify a 'design density' for each hazard class in terms of an effective discharge rate expressed in mm min⁻¹ (depth of water applied per minute of operation per unit area). The flow rate over the area operation can therefore be estimated.

BS EN 12845:2004+A2:2009 Section 8.1.1 specifies the minimum period over which the system should operate depending on the hazard class from which the total volume of water discharged via the sprinklers can be estimated.

However, where the system is connected to a town supply, there is in effect an exhaustible supply available and therefore the sprinklers could run for a considerable period of time.

The standard does not cover firefighting water that may be used other than in fixed sprinkler installations. So it may be necessary to allow for additional water applied to a fire by the Fire and Rescue Service and/or the occupational fire brigade in circumstances where the sprinkler system has been unable to extinguish the fire.

4.3.4.6 National guidance document on the provision of water for firefighting

Guidance by Local Government Association and Water UK (2007) has been published to promote co-operation between the Fire and Rescue Services and the water industry. Appendix A5 provides general flow requirements for firefighting for differing types of development.

4.3.4.7 Conclusions on forecasting firefighting water

This section provides guidance on a number of methods for estimating the potential volume of firefighting water that should be retained following an incident. It is not possible to offer any definitive guidance on the most appropriate method to a particular site and each will undoubtedly provide a different result. However, they will provide a starting point for discussion with the regulator and the Fire and Rescue Service from which a credible incident response scenario can be developed.

Box 4.2 recommends the issues that should be discussed with the Fire and Rescue Services to aid estimation of the volume of firefighting and cooling water that might have to be contained during an incident.

Box 4.2 *What to ask the Fire and Rescue Services*

What type and number of appliances would attend the site as part of a first response to an incident?
What is the capacity of these appliances?
Based on their experience of incidents at similar facilities, for how long would they anticipate having to apply firefighting and/or cooling water and/or foam?
Are they aware of any restrictions on the supply of firefighting water to the site?
If the incident were to escalate, what is the likely maximum number of appliances that could be called to the site?

Box 4.3 *Fire duration*

Where flammable materials are stored, estimating the potential duration of a fire has important consequences for:

- estimating the volume, of firefighting and cooling water that may have to be applied during an incident (an issue considered in this chapter)
- the fire resistance of the components of the containment systems including the walls, and perhaps more importantly, the materials used to seal any joints. These issues are discussed in Part 3.

The likely duration of an incident is clearly an imponderable, however, credible scenarios should be developed in consultation with the Fire and Rescue Services to inform the design of the containment system in respect of the issues discussed here.

It is noted, however, that commonly available intumescent construction sealants are fire rated for up to four hours. So, in the absence of any other information on the likely incident scenario, a minimum fire duration of four hours should be adopted when considering the application of firefighting and cooling water.

Table 4.6 summarises the site specific factors that might limit the volume and/or application rate of firefighting and cooling water during an incident.

Table 4.6 Factors that might limit delivery rates and volumes of firefighting and cooling water

Volume	Rate of delivery
<ul style="list-style-type: none"> ■ total stored on site in emergency storage ■ rate of replenishment from mains or other supplies ■ hydrant supply capacity – note for large sites, supply may be from different capacity mains or systems ■ number of firefighting tenders attending incident and their capacities ■ local supplies, ie rivers, lakes ■ potential for firewater recycling. 	<ul style="list-style-type: none"> ■ sprinklers ■ monitors ■ hydrants ■ firefighting tenders ■ pumps (from local supplies).

4.4 FREEBOARD IN BUNDS AND DYNAMIC EFFECTS

Freeboard is the increased height allowed in the design of structures to account for uncertainty. Using a sea wall as an example, a freeboard allowance would be made to increase the crest height of the wall to cater for the quantified effects of wind and waves, and other dynamic forces.

In the context of this guidance, it is an increase in the height of a containment wall to provide additional capacity over and above the minimum design volume requirement. As discussed in Section 4.3.4, a minimum freeboard of 100 mm should be allowed for firefighting agents (foam) in addition to the height of wall required to contain the volume of inventory plus rainwater.

In addition, the surge effects of the catastrophic failure of the primary storage vessel should be considered either explicitly in the design of the containment, or by making a suitable freeboard allowance. Quantification of such effects has been researched as summarised in Box 4.5.

Box 4.5 Summary of research on overtopping of bunds

Laboratory testing by Liverpool John Moores University for the Health and Safety Executive (Atherton, 2005) considered the overtopping of a vertical bund wall following the catastrophic failure of a primary containment tank. Such failures are rare, however experience has shown that when they do occur, a large proportion of the liquid is likely to escape over the surrounding bund wall or embankment even if the force of the wave impact does not damage the retaining structures.

The experimental work considered a number of tank and bund configurations, concentrating primarily on the ratio of the height of liquid stored in the tank to the height of the bund wall and the distance of the tank from the bund wall. As might be expected, a significant proportion (up to 70 per cent) of the liquid stored in a tall tank close to a low bund wall was lost to the containment.

Put into context of perhaps a 'real world' situation, the research indicates that following a catastrophic collapse, approximately 50 per cent of the inventory stored to a depth of 6.0 m in a tank located 7.0 m from a 1.2 m high vertical bund wall would not be retained by the secondary containment. Doubling the height of the wall would reduce this figure to about 25 per cent.

Earth embankment bunds that tend to have sloping faces were not tested, however, it could be anticipated that the losses would be even greater.

Similar experimental work was completed by Greenspan and Young (1978) as cited in WS Atkins Consultants (2001). This experimental work developed a relationship purely based on the ratio of the bund wall height to the height of retained inventory. Using the Atherton example, the Greenspan and Young work suggests that for a vertical wall again approximately 50 per cent of the inventory would be lost following catastrophic failure of the primary containment.

The research included sloping bund walls and as might be anticipated, a greater loss of inventory was predicted.

It is clearly impractical to construct a local secondary containment facility to prevent any spillage of stored materials following the catastrophic failure of the primary containment. While this mode of failure is rare, in high hazard situations consideration should be given to the provision of tertiary containment to cater for the 'failure' of the secondary containment. This mode of failure should be considered as part of the risk assessment process.

The work described in Table 4.7 is largely experimental and there is a degree of uncertainty in applying the results in designing a bund wall to cater for the potential effect of surge. So, in the absence of detailed analysis the following set out in Box 4.6 should be made where catastrophic failure of the primary storage vessel is considered a credible scenario.

Table 4.7 Surge allowance (in the absence of detailed analysis)

Type of structure (see Part 3)	Allowance
<i>In situ</i> reinforced concrete and blockwork bunds	250 mm
Secondary containment tanks	250 mm
Earthwork bunds	750 mm

Case study 4.1

Example of managing potential effects of overtopping, Plymouth, UK

Greenergy Plymouth Tank Farm site dates back to the late 1890s. The Mayflower and Cattedown Terminals were acquired as operating terminals in May 2008 and, following a review of systems and infrastructure, a major terminal upgrade project was completed including the upgrading or replacement of five tank bunds.

The joints to the existing concrete bund walls were re-sealed with fire retardant filler and over-plated stainless steel plate. A geomembrane liner with a basalt stone protection layer was laid over earth bund floors.

Two new bund walls were constructed, one with a propriety precast concrete wall system with joints again sealed with fire retardant filler and over-plated stainless steel plate, and the second using *in situ* reinforced concrete.

A review of major accident hazards determined that the catastrophic failure of one of the tanks could result in overtopping due to its proximity to the bund wall with losses into the adjacent Plymouth Sound estimated to range from 53 to 66 per cent of total tank inventory. To manage this risk a deflector plate was designed to minimise any losses on the seaward side of the tanks as well as prevent inundation from an extreme sea level surge and high waves.



4.5 SUMMARY OF RETENTION CAPACITY RECOMMENDATIONS

In the absence of any regulatory specific recommendations, such as facilities that fall within the scope of the OSR or COMAH containment policy, Table 4.8 summarises the guidance on containment capacity requirements and the process for estimating containment capacity is shown by Figure 4.3.

Table 4.8 Summary of retention capacity recommendations

Factor to be considered	Local containment capacity recommendations	Remote and combined system capacity recommendations
Primary storage capacity (ie possible storage inventory) Note this may be limited by the credibility of the scenario and need not necessarily result in a complete loss of inventory	Capacity at least 100% of primary capacity for single tank installations. Capacity based on risk assessment based on credible scenario for multi-tank installation taking into account tertiary containment provision.	Capacity at least 100% of primary capacity. Include capacity of all primary tanks in multi-tank installations.
Rainfall	For uncovered bunds provide sufficient freeboard for 10% AEP rainfall for: <ul style="list-style-type: none"> ■ 24-hour ■ the duration of the incident, plus ■ eight days (or other period appropriate to the particular site circumstances). 	As for local containment capacity recommendations plus an allowance for rain falling directly on to remote containment and areas of the site draining into it.
Firefighting and cooling water	No allowance specifically for firefighting water. Addressed via tertiary containment. Allowance for cooling water, or procedures for re-circulating cooling water, to be agreed with the Fire and Rescue Service.	Allowance for extinguishing and cooling water delivered through fixed and non-fixed installations based a credible scenario agreed with regulators and the Fire and Rescue Service. Development of the scenario can be informed with reference to the methods contained in ISO/TR 26368:2012 and by BS EN 12845:2004.
Firefighting agents (foam)	Allow freeboard height of containment required for primary inventory and rainwater of not less than 100 mm.	Allow freeboard height of containment required for primary inventory and rainwater of not less than 100 mm
Dynamic effects	Allow freeboard as set out in Box 4.5. For high hazard situations, consider impact of overtopping of the containment resulting from a catastrophic failure of the primary containment. Consider remote secondary or tertiary containment.	More appropriate means of containing inventory following a catastrophic failure of the primary containment.

The designer of the containment system should take into account the probability of a number of events occurring simultaneously. The worst case scenario for containment is represented by the design return period rainfall (eg the rainfall that is likely to occur, eg once in 10 years) coinciding with the sudden and total loss of primary containment and a fire involving applied firefighting water. At low risk sites or sites where it can be demonstrated that the probability of a simultaneous occurrence of events is sufficiently low, it may be possible to apply less stringent capacity requirements. Such relaxations should be subject to the designer's and site operator's discretion and the agreement of the various regulatory bodies in the light of the particular circumstances.

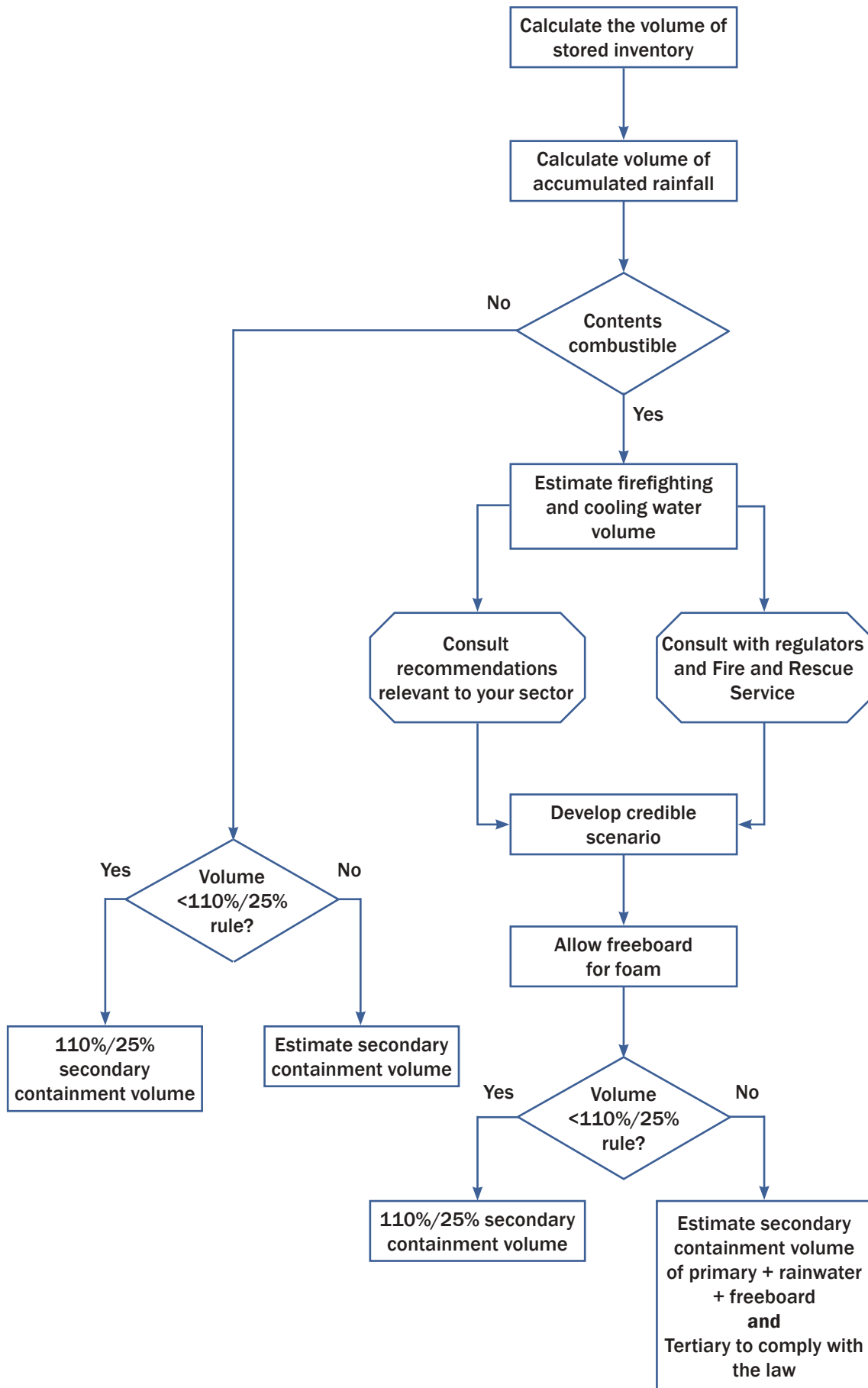

Figure 4.3 Process for estimating containment capacity

5 Existing installations

This chapter provides:

- An introduction to the classification, inspection, maintenance and modification of existing installations (Section 5.1)
- Advice on developing maintenance plans for existing facilities (Section 5.2)
- Advice on the classification of existing facilities based on the risk assessment methodology introduced in Chapter 2 (Section 5.3)
- Guidance on completing a baseline survey of an existing facility where no or limited records are available (Sections 5.4 to 5.7)
- Advice on completion of a gap analysis to establish the extent to which an existing facility meets regulatory requirements (Section 5.8)

5.1 INTRODUCTION

5.1.1 Asset management of existing facilities

In the UK, very few new containment systems are being built at this time. Much of the construction effort in containment systems involves:

- extension to existing facilities
- rearranging the containment to suit new production or process requirements
- upgrading to newer standard, often including a change in ownership of a facility.

As set out in the *Foreword*, CIRIA R164 focused principally on the construction of new containment facilities. However, this update provides guidance on managing existing older facilities. New aspects introduced include assessing the life expectancy of components and how best to inspect, maintain and repair them, as well as advice on modifying and extending them.

Recent inspections of existing containment facilities have identified significant uncertainty regarding the form of the construction and its compliance with good practice recommendations (HSE, 2011). Creating 'as-built' design information provides a sound basis not only to allow the designer and contractor to make informed decisions about how best to extend an existing facility, but also to assist the duty holder to demonstrate to the regulator that good practice is being implemented.

Attention is drawn to the requirements of the scope of the FWMA in relation to containment systems discussed in Chapter 1. Where a containment facility falls within the scope of the Act, a mandatory inspection regime may be required, irrespective of the form of construction.

5.1.2 Overview of chapter

This chapter draws together the recommendations that are relevant to the modification, extension or refurbishment of an existing facility that may also include the situation where a change in the nature of the inventory is required, or if the inventory is re-classified. It aims to enable the duty holder to ensure that their facility meets any minimum legislative or regulatory requirements.

Where records are incomplete or non-existent, a programme of investigation and analysis is likely to be required to demonstrate compliance, or highlight shortcomings with respect to legislative or regulatory requirements.

To consider the performance of a facility against the guidance contained in this publication, it will first be necessary to establish the class required for the installation as defined in Chapter 2. The information required to establish the class will fall broadly under the following headings:

- Volumes of primary and secondary and tertiary containment.
- Nature of material being stored and compatibility with form of construction.

- Potential pathways to sensitive receptors (drainage systems, topography etc).
- Form of construction of containment system (concrete/blockwork/earthworks etc).
- General condition of the facility (integrity of joints/penetrations, defects etc).
- In-service performance (ability to withstand applied loads/fire resistance).

Following this process should result in classification requirements for the containment against which the existing installation can be judged.

It is recognised that establishing the form of construction and in-service performance where no formal construction records are available is likely to require some form of specialist intrusive investigation. Guidance is provided on appropriate means of completing this 'baseline' survey in Section 5.4.

In circumstances where the baseline survey indicates that the class of containment for the existing facility falls short of that required by guidance, advice is provided on appropriate means of addressing the shortfall, ie a 'gap analysis', in Section 5.8. The gap analysis provides both a review of the risk assessment to identify any procedural methods that could be put in place to reduce the risk, as well as measures to address any particular issues with the construction of the containment system.

While the guidance in this chapter is aimed principally at 'benchmarking' a facility against the guidance contained in the rest of this publication, it is likely to be of value in establishing compliance with statutory or regulatory regimes.

The extent to which the benchmarking of a facility would lead to the retrospective application of remedial measures will depend on regime specific requirements. This is discussed in Chapter 1.

A flow chart summarising the process of assessing and classifying existing structures against the guidance contained in this publication is provided in Figure 5.1.

5.2 MAINTENANCE PLANS

A regular maintenance and inspection regime is essential if defects or leaks that could compromise the integrity of the primary, secondary or tertiary containment are to be identified in a timely manner. The EPR, PPC and COMAH Regulations require adequate inspection/maintenance procedures to be in place. Being unaware of defects in the containment facilities would be no defence should a pollution incident occur.

There is currently no specific guidance available on an appropriate inspection regime for containment facilities. However, EI (2010) provides an approach to managing inspection and maintenance as summarised in Box 5.1.

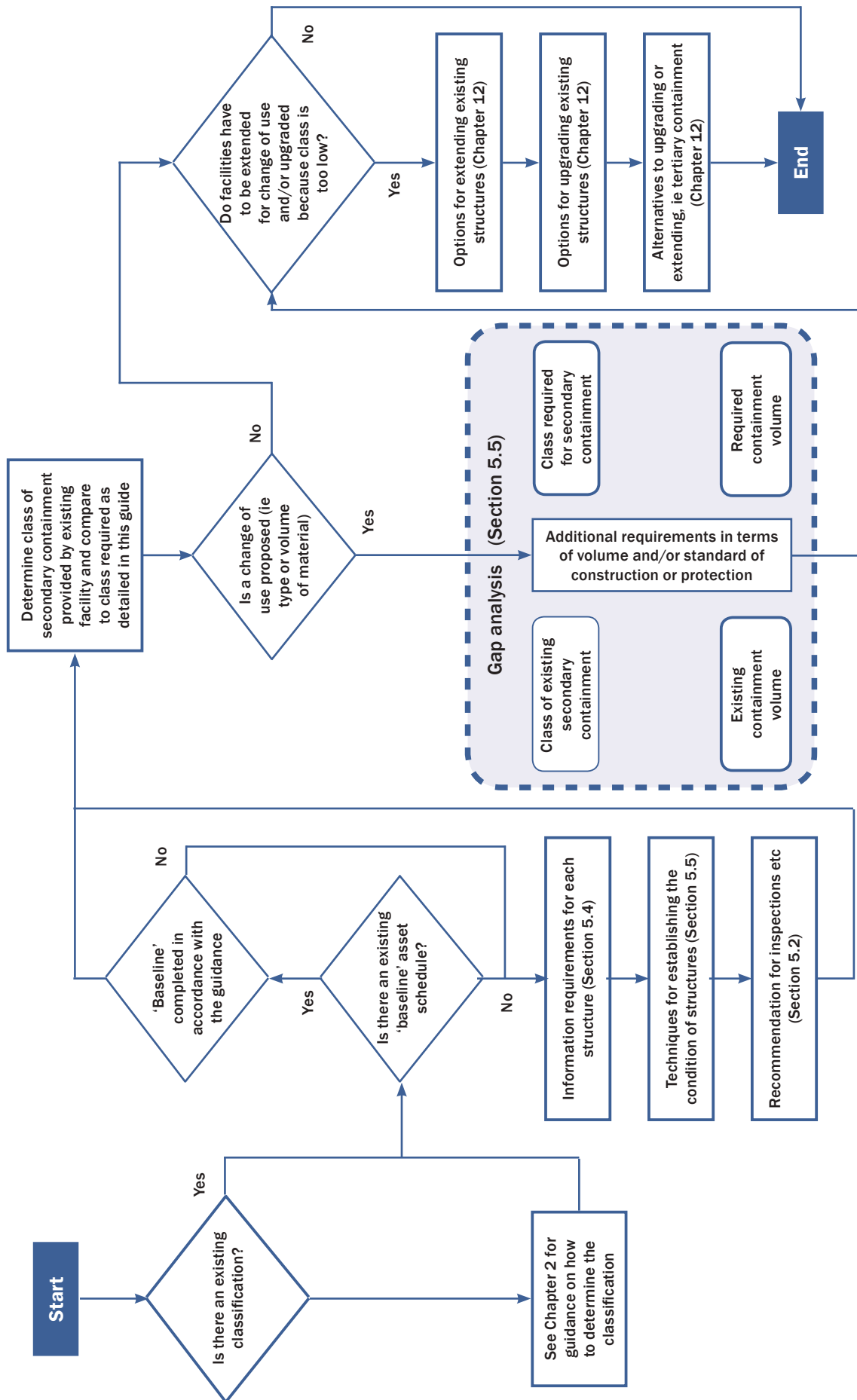

Figure 5.1 Assessing and classifying existing structures

Box 5.1 *Summary of high level framework for process safety management (from EI, 2010)*

Maintaining the integrity of plant and equipment is an essential requirement for health, safety and environment (HS&E) and process safety.

Management must ensure that the necessary inspection and maintenance requirements are identified and carried out to reduce the likelihood of a significant incident as a result of failure of plant or equipment.

It is recommended that:

- 1 Assets are uniquely identified on an asset register, which provides up-to-date asset lists and equipment records, including location and equipment specification data. The asset register provides a basis for inspection and maintenance planning.
- 2 The asset inspection and maintenance programmes are risk based and address and integrate long term asset integrity, HS&E and process safety compliance assurance.
- 3 There are procedures to ensure that asset inspection and maintenance programmes are reviewed regularly commensurate with risk, using findings from the programmes, industry experience and incidents to identify and address issues and opportunities for improvement, so that they are kept up-to-date as living systems.
- 4 Feasible plans and schedules are developed for execution of asset inspection and maintenance programmes.
- 5 Adequate numbers of competent personnel are available to carry out the inspection and maintenance programmes.
- 6 There are procedures to ensure that findings and recommendations from the asset inspection and maintenance programmes are appropriately prioritised and followed up.
- 7 Inspection and maintenance programmes are approved by specific named competent individuals.
- 8 Deviations from approved inspection and maintenance programmes are approved by specified named competent individuals commensurate with the risk.
- 9 Arrangements for inspection and maintenance programmes are understood and followed, and understanding of arrangements and compliance with them is regularly tested.

Compliance and performance trends are reviewed by specified levels of management.

Advice on developing an asset register for containment systems is provided in Section 5.4 and should be developed on a site by site basis.

Recommendations on asset inspection and maintenance programmes can be found in Chapter 5 of EI (2007) and is summarised in Box 5.2.

Box 5.2 *Suggested inspection and maintenance regime based on advice contained in environmental guidelines for petroleum distribution installations (after EI, 2007)*

Daily

- Walk round the site, identify and clear up any waste materials.
- Note signs of any deterioration of tanks or surroundings.
- Note any small leaks or spills, fix them and clean them up immediately.
- Check the separator(s) to ensure they are operating correctly.
- Inspect the tank bund valves to ensure they are closed.
- Remove any excess water from tank bunds (and other compounds) in accordance with the agreed procedures at the site. If rainwater is not accumulating where it might be expected, this can provide indication of a leakage from the containment and should be investigated further.
- Check drip trays and pans.

Weekly

- Remove any surface oil in the separator.
- Check that drain covers/grids are clear of debris.
- Wet stock reconciliation: compare metered usage of product recorded through pumps, and usage of stock in tank storage measured through regular tank dips.

Monthly

- Sample outflow from separators and analyse to check for compliance.

After rainfall

- Check external floating roofs and drain off accumulated water.
- Draw off water from external floating roof tanks if required.
- Check tank bunds and remove any excess water in accordance with the agreed procedures at the site. The oil-water separator should be inspected regularly. Arrange for accumulated silt to be removed when required, ensuring that the separator is refilled with water.

Containment facilities

Inspection and repair of containment structures should be carried out on a regular basis and the results recorded. For example, cracks in concrete, failure of flexible seals around pipes as they pass through bund structures and animal damage to earth bunds can all compromise the integrity of secondary containment systems. Instruction signs should be maintained and essential equipment, such as valve keys, should be checked to ensure they are in place. The location of any faults or defects should be recorded on a plan and linked to maintenance records of the actions taken to remediate them.

Inventory checks

These checks are based on:

- The level of the product in the tank (level check), or
- The mass of the product in the tank under static conditions (mass check), or
- The difference between the volumes pumped in and out of the tank over long periods compared to the change in stored volume.

The inventory checks are of particular importance as they can give the first indication of leakage from the primary containment where it is not necessarily visible.

Where components are critical to the performance of the containment system, the inspection should be completed by a competent person experienced in the particular type of structure, ie reinforced concrete walls, reinforced masonry walls, earth embankments, lining systems etc.

As a general guide it might be expected that:

- daily/weekly inspections are completed by the operations staff
- there is a formal inspection of the containment facilities by the works engineer every 6 to 12 months
- a detailed inspection of the containment facilities by a competent person or persons every five years.

However, the inspection regime should be developed in consultation with the regulator to be appropriate to risk and the age of the facility.

5.3 RISK ASSESSMENT AND CLASSIFICATION OF CONTAINMENT SYSTEMS

The starting point for any assessment should be a site risk assessment as described in Chapter 2. The output from the risk assessment is used to determine the appropriate class of secondary containment.

A duty holder should be able to demonstrate that the class of the existing containment is appropriate to the site risk rating, or if it is not, that there are other measures in place to reduce the risk of a loss of primary containment sufficiently to satisfy the law. This may be, for instance, the provision of tertiary containment.

The site risk assessment and containment classification should be reviewed periodically, but at least every five years or any other period agreed with the regulators, or where:

- there are any modifications made to the primary, secondary or tertiary containment
- the volume of material in the primary containment is increased
- the nature of the material in the primary containment is changed
- the nature of the material is reclassified
- the potential pathways and/or receptors have changed.

The third point is particularly relevant as this may increase the class of containment required and this might be difficult to achieve with the existing arrangement. For instance, blockwork bund walls are not suitable for providing class 2 or class 3 containment, or where fire resistance is required (see Section 7.3).



5.4 BASELINE SURVEY

5.4.1 Introduction

For facilities constructed post-1994, a full set of design documentation and construction (as-constructed) drawings should be available for a containment facility for all but the smallest sites. These records would have formed part of the health and safety file, which was a requirement of the Construction (Design and Management) (CDM) Regulations 1994 and more recently the Construction (Design and Management) (CDM) Regulations 2007.

However, it is commonplace, particularly for older sites, to find situations where the original design and/or as-constructed drawings are not available or are unclear. In these circumstances a baseline asset survey of the facility should be completed and reviewed by a competent person to demonstrate it is reducing risk sufficiently to satisfy the law. This type of baseline survey is often completed for bridges and older concrete structures where modifications are planned.

For a containment facility the baseline survey should include, but not be limited to, the information contained in Box 5.3.

Box 5.3 *Suggested scope of baseline asset survey*

Primary containment

- Volume.
- Nature of inventory.

Containment

- Local, remote and/or combined.
- Secondary and/or tertiary.
- Containment volumes for individual containment elements and site wide.
- Was the facility constructed to conform to a particular containment class (if known).

Type of construction (see Part 3)

- Concrete, blockwork, earth bund, tank etc.
- Design standards used, ie CP 110-1:1972, BS 8110-1:1997, BS 8007:1987 or BS EN 1992-1-1:2004 (Eurocode 2) etc (if known). If the year of construction or modification can be established, the design standard used can be established with reference to Boxes 5.4 and 5.5.
- Details of any linings/coating to the containment and the substrate this has been applied to (eg concrete or masonry).
- Reinforced masonry walls – check for the presence of reinforcement that is continuous and passes into the anchoring beam or slab.
- Where the bund is constructed in concrete or blockwork, the location, orientation, spacing and detailing of any joints and their ability to provide watertight containment.

Potential leakage pathways (see Part 3)

- Presence of waterstops in walls and floors across joints, including type/material.
- Presence of joint armouring plates across joints.
- Penetrations through the containment – type, method and type of sealing and age.
- General watertightness.
- Leak detection systems if installed.
- Means of emptying rainwater.
- Full details of the site drainage system.

Defects noted should be recorded on a plan, dated, photographed where appropriate and details of remedial works recorded along with date completed. Defects that should be recorded might include, but not be limited to:

- leaking cracks
- spalling of concrete or blockwork walls or base
- signs of corrosion in reinforced concrete or block work wall (rust staining etc)
- failures of sealing of pipe penetrations, wall joints and floor joints
- sealant has exceeded lifetime recommended by supplier

- misaligned sections of wall
- slumping of earth banks or noticeable variation in level along the crest
- animal burrows in earthwork embankments
- torn or damaged liners
- coatings de-bonding from the wall.

Failures that clearly compromise the containment integrity, for example holes or cracks that penetrate the bund wall, collapsed walls, missing floor sections etc should be rectified using risk-based prioritisation.



Figure 5.2 Arrow shows leaking crack in a bund wall (courtesy CH2M Hill, with permission from the Environment Agency)



Figure 5.3 Spalling of concrete over corroding reinforced bar, where cover is reduced by groove feature (courtesy CH2M Hill, with permission from the Environment Agency)



Figure 5.4 Rust staining that may indicate corroding reinforcement (or a metal fixing) (courtesy CH2M Hill, with permission from the Environment Agency)

Containment facilities should be inspected by a competent person who is familiar with the type of construction. This requirement applies to all persons involved in any subsequent repair process, including scheme designers, contractors and works inspectors.

5.4.2 Volumes of primary, secondary and tertiary containment

Volume of primary containment

Assessing the volume inventory held by the primary containment is addressed in Section 4.3.2.

Volume of secondary and tertiary containment

For smaller containment areas, where the base appears relatively level and the crest of the containment is at a constant height, it will be satisfactory to estimate the volume from the plan area and height to the crest of the containment.

For extended containment areas, simply multiplying the plan area of the containment by the height of the wall at its lowest point might overestimate the containment volume if there are significant variations in the level of the base (for instance if it is sloping to facilitate drainage). This is particularly the case for embankments with sloping sides. In these circumstances a topographic level survey of the base and walls should be completed to ensure the volume of containment is calculated to a reasonable degree of accuracy.

The topographic survey should also confirm that the crest of the bund is level. If not, calculating the effective containment volume should be based on the level of the lowest point on the crest of the bund.



Figure 5.5
Slumping of earth embankment

A topographic survey can also be used to generate a detailed plan layout where one does not exist.

When comparing against the 110 per cent capacity rule (see Section 4.2.1) the volumes of any parts of primary containment capacity below the level of the secondary containment except for the largest tank in the bund should be deducted from the overall secondary containment volume. This includes any supports, bases, pipework etc. When comparing against the 25 per cent rule, the volumes of any parts of primary containment capacity below the level of the secondary containment, supports, bases (including all tanks that are assumed to be

undamaged) and the like should be deducted from the overall secondary containment volume. This is shown in Figure 5.6.

Where there is a combined containment systems in place (local and remote) there may be significant containment volume in the transfer system. It may be appropriate to take this into account subject to a survey to confirm the volume and condition of the transfer system (see Chapter 10). When assessing the storage potential of the transfer system, care should be taken on sloping sites to ensure only the volume in the system up to the lowest point is taken, rather than the capacity of the pipes, manholes and/or channel.

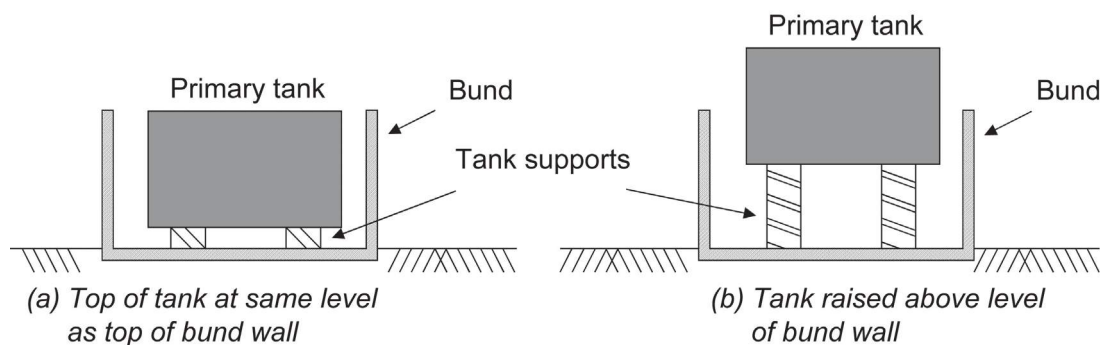

Figure 5.6 *Interpretation of the 110% capacity rule*

Case study 5.1

Example of inadequate secondary containment and drainage, Huddersfield UK (courtesy Environment Agency)

This case study relates to a manufacturer and repackager of a variety of chemicals such as fungicides, insecticides, pharmaceutical products and polymers. The site in the North East was bounded on the north side by the Huddersfield Narrow Canal, and on the remaining three sides by the River Colne.

In the early hours of 24 May 2010 a fire broke out in the engineering block in the north-west corner of the site. The fire is thought to have been caused by a pinhole leak of diesel fuel spraying onto the hot surface of the boiler and eventually igniting. The fire quickly spread to the waste area adjacent to the engineering block. This, in turn, ignited intermediate bulk containers (IBCs) containing solvents, which were stored in an open air waste compound adjacent to the engineering block and initiated a running pool fire, which soon overwhelmed the secondary containment available and spread to the warehouse building and then towards the bulk storage containment area in the centre of the site. The fire and rescue service were able to provide cooling to prevent the fire from spreading into the bulk storage area.



Approximately 5000 m³ of firefighting water and 20 m³ of foam were applied to the site in the first five hours of fighting the fire. The site's tertiary containment system was not able to cope with the quantities of firefighting water runoff and foam generated and consequently significant quantities escaped the site boundary into the River Colne.

Investigation of the incident identified that there were a variety of issues including the following:

- Inadequate drainage. Some of the drains were too small and the drains had not been inspected for a number of years and were unable to cope with the large volume of firefighting water runoff products. In addition, the part of the drainage system that relied on pumps was overwhelmed due to a lack of pump capacity and finally became unavailable when site power was switched off for safety reasons.
- The secondary containment to the bulk tanks was inadequate and in particular around the effluent tanks where the capacity was less than 110 per cent of the largest tank in the bund. It was also noted that the bund wall was cracked.
- Tertiary site containment was a combination of the effluent tanks, kerbing and drainage and was approximately 470 m³ – considerably less than the firefighting water and foam applied during the May 2010 incident.
- Poor storage of portable containers containing, in particular, flammable materials. During the fire, there were some plastic IBC containing flammable materials, which melted. The flammable materials caught fire and became mixed with other liquid materials that had escaped from plastic containers, at the site to cause a running pool fire across the ground, spreading the fire further.

Since the fire the company has made the following improvements:

- Repaired the kerbing along the southern boundary of the site, which is the most vulnerable area due to the slope of the site.
- Surveyed and traced all the site drainage to understand how firefighting water is transported around site during an incident.
- The quantity of firefighting water runoff, which might be generated during a future incident, has been assessed to evaluate what needs to be managed during the case of any future incident. With improvements on handling materials on site and discussions with the Fire and Rescue Service, the maximum quantity of firewater runoff has been estimated at approximately 3000 m³.
- Designed and built a containment system to contain the full contents of all the portable containers such as IBCs, containing flammable materials to minimise the risk of a fire involving the liquids in those containers spreading to neighbouring parts of the site.
- Reviewed their procedures for segregation of incompatible chemicals such as oxidisers and flammable materials.
- Improved bunding of bulk storage tanks containing flammable liquids.

Work is still ongoing at the site focusing in particular on combining the information gathered during the drain survey and calculation of firewater runoff to derive a plan for managing firefighting water runoff from future incidents.

There is also a programme in place to repair and improve the remaining existing bunds and also to establish a tertiary containment plan. The plan is likely to require improvements in transferring firewater runoff to the lowest part of the site by use of bund walls around the site boundary and large pumps, which will runoff an alternative power supply to the main site supply.

5.4.3 Nature of material being stored and compatibility with form of construction

Over time the nature of the material contained in the primary containment may have changed from when the facility was first installed.

It is therefore important to establish if the contents would be damaging to the containment system, ie are they likely to be aggressive to any existing concrete or blockwork walls or bases, joint sealants, lining systems, coatings or drainage systems where installed?

Where more than one material is stored within a common containment system, the effect of the 'cocktail' of chemicals on the bund and lining system should be assessed. However, chemicals that react with each other liberating heat and/or noxious gasses (ie incompatible materials defined in CA, 2008a) should not be stored within tanks protected by a common bund.

5.4.4 Potential pathways to sensitive receptors

Means of emptying rainwater

The means of emptying accumulated rainwater from within the bund should be established. Under no circumstances should an uncontrolled gravity discharge of rainwater from a containment bund be permitted, even where routed via an interceptor, unless it is draining to a further (tertiary) stage of containment.



Where this is a gravity connection, even when controlled by a penstock or valve, for a class 2 facility, this should be taken out if practicable. However, for a class 3 facility, these arrangements should be replaced with either a portable or fixed installation pump.

Rainwater that has accumulated within a containment bund may be contaminated by spillages and leakage from the primary containment. Rainwater should be tested before discharge to any drain or sewer, unless it is to be routed to treatment works specifically designed to accommodate this effluent. Procedures should be in place to remove any contaminated rainwater to a WWTW.

Site drainage and transfer systems

Should a containment system fail, it is important to identify all the possible pathways by which contaminants could reach sensitive receptors. One of the most common pathways is the site drainage system that might, for instance, discharge to a water body or to the ground.

Where there is any uncertainty about the layout, condition or capacity of drainage systems for trade waste a survey should be carried out. Potential hazards in terms of the system's ability to cope with major incidents should be identified. Typical hazards might include:

- combined surface and trade waste systems, especially where provided with storm overflows on or off-site
- direct runoff to surface and groundwaters (ie rivers and soakaways respectively)
- infiltration of contaminants through defective drainage
- unprotected clean water gullies and other devices for collecting stormwater from areas likely to become contaminated
- unprotected downpipe pipes on buildings that, if damaged (typically in a fire), could allow pollutants to enter storm drainage
- inadequate or poorly maintained valves and other devices used for flow control
- defective pipes or joints
- blocked gullies, pipes and drains
- inadequately sized systems (hydraulic capacity of the pipe is less than the estimated maximum flow – see Chapter 10)
- inadequate robustness or durability.

Any gullies or drains within the secondary containment should be identified and traced to ensure they do not provide a pathway for contaminants. Care should be taken on older sites, particularly those that may have been redeveloped to check for the presence of historic redundant systems, such as land drains, soakaways, abandoned boreholes sewers etc, which can provide such paths and compromise the integrity of the containment systems.

If comprehensive records are either not available or have not been maintained, the site drainage system (including surface water, foul and trade effluent systems) should be surveyed. This is normally completed by a CCTV survey that will also provide evidence of physical defects with the pipe work such as broken pipes, misaligned joints, root intrusion etc.



Figure 5.7
CCTV survey equipment and of a defect in a pipe (courtesy InSewer Surveys)



Note the blue PVC waterstop in the centre of the wall and full-depth honeycombed concrete in the lower core hole that is not evident at the surface.

Figure 5.8 Investigation of a wall joint (courtesy Environment Agency)

Once potential pathways have been established, the integrity of the pipe runs should be checked using a falling head test completed in accordance with BS EN 1610:1998.

Any drainage system that could provide a pathway for contaminated water if the secondary containment fails should have a means of closing the outfall at the site boundary or point of discharge. There are a number of proprietary systems available that can be operated remotely, or in reaction to changes in the quality of the discharge.

It should be noted that many sluice valves require a pressure head to seal effectively and therefore at low flows may not provide effective containment. So, if a valve is to be relied upon as part of the site containment, care should be taken to ensure it will provide an effective seal under the anticipated operating conditions.

However, once the outfall has been closed, the capacity of the drainage systems and any interceptors may be exhausted very quickly during an incident and may lead to spillage from manholes and chambers. This scenario should be considered during the risk assessment process to ensure that spillage from manholes can be contained.

In many cases the surface water drainage system on an industrial site will be provided with an interceptor to remove hydrocarbons washed from the surface of internal roads and areas of hardstanding. However, these are unlikely to be effective during an incident where the secondary containment fails and should not be relied upon to retain contaminated water entering the system as their operating capacity is likely to be exceeded. It should also be noted that firefighting foam inhibits gravity separation of hydrocarbons.

5.5 ASSESSMENT OF SPECIFIC CONSTRUCTION TYPES

5.5.1 Introduction

Determining the specific type of construction can be the most problematic issue in situations where no records exist. Fundamentally, the containment has to withstand the hydrostatic and hydrodynamic pressures should the primary containment fail and remain watertight for a minimum of eight days. This

is because following an incident, it may take a number of days to arrange for the disposal of the inventory and any contaminated firefighting water and foam.

In addition, where flammable materials are stored, the containment, including all its components (eg waterbars and sealants) should be capable of withstanding a fire.

The guidance set out below provides advice on assessing the integrity and structural performance of a secondary containment facility.

5.5.2 Competence

Where structural and/or geotechnical investigation and analysis is required to determine the form of construction of an existing facility, the advice of a competent person should be sought.

5.5.3 Investigation approaches

It should be noted that intrusive investigations, ie coring, can carry risks such as creating pollutant pathways through poor quality reinstatement of the core hole. Therefore, care should be taken to design the investigation to minimise such risk such as coring from the top, or from the outer face.



Where intrusive investigation is required, it should be co-ordinated with periods of routine maintenance (eg examination of form of construction of joints to coincide with sealant replacement, which should occur in accordance with the manufacturer's recommendations).

There are also a range of non-destructive tests (Bungey *et al*, 2006) that can provide information on the form of construction.

However, intrusive investigations should be not delayed if:

- the containment system is required to be class 3 and there is a lack of required asset information
- concerns have been raised (inspection/testing/rainwater leakage) over the integrity/suitability of the existing containment.

Where it is not reasonably practicable or considered uneconomic to determine the integrity and performance of a containment system, alternative means of reducing the potential risks sufficiently to satisfy the law should be sought such as providing tertiary containment.

5.5.4 Blockwork/brickwork

A well-rendered wall may easily be mistaken for a reinforced concrete wall. It may also be difficult to confirm if the wall has been reinforced. The retrofitting of cladding (sometimes undertaken for visual as opposed to pollution control reasons) may further obscure the condition.

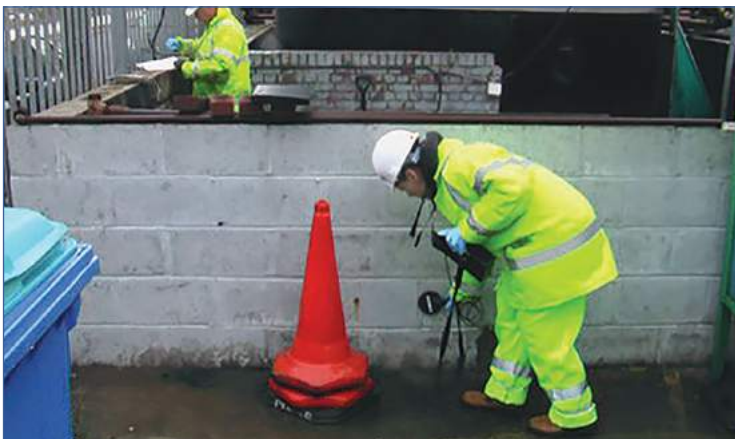

Figure 5.9
A cover meter survey (courtesy CH2M Hill, with permission from the Environment Agency)

The structural strength of a blockwork or brickwork wall and its ability to withstand the loads imposed upon it depend not only on the reinforcement (if present) but the foundations.

If there are no details available, this will require investigation and is likely to include a dimensional survey, a cover meter survey to locate and size any reinforcement, and localised excavation of the foundations. Some intrusive investigation (breaking out local areas of wall) may also be required.



Figure 5.10 A metal waterstop in a wall joint (courtesy Environment Agency)

With the results of such an investigation, and with reference to design codes that were in force at the time when the wall was constructed, it may then be possible to estimate the structural strength of the wall. However, in practice, it is likely to be preferable to complete an *in situ* load test on the wall to determine if there would be significant movement or failure under service conditions. This is discussed in Section 5.7.2.

It should be noted that reinforced blockwork and brickwork is suitable only for class 1 containment, where no fire resistance is required and where it has been designed and constructed in accordance with a recognised code of practice (see Section 7.3). Good reinforcement should be continuous for the whole height of the wall and properly tied into the foundations. Typical details of properly reinforced blockwork and brickwork walls are given in Appendix A7.

If the blockwork or brickwork wall is unreinforced, then a structural assessment and risk assessments should be carried out to confirm satisfactory performance under relevant loads. If it is considered unfit for purpose, then engineering solutions should be considered to improve the integrity of the structure. This could involve replacement, strengthening, or the introduction of alternative containment measures such as using the blockwork wall as permanent formwork for a new reinforced concrete wall.

5.5.5 Reinforced concrete walls (with and without concrete bases)

As with blockwork walls, the structural strength of a reinforced concrete wall depends on the reinforcement, the specification of the concrete mix, and its foundations.

If the age of the structure is known, then it may be possible to infer some details of the construction from the structural code that prevailed at the time. The first national code of practice for reinforced concrete published in the 1930s has evolved ever since. A summary of the principal changes in reinforced concrete codes for structural and water retaining elements from CP 110-1:1972 and BS EN 1992-1-1:2004 (Eurocode 2) are provided in Boxes 5.2 and 5.3. For details of concrete design codes that preceded CP 110 earlier reference can be made to Clarke (2009).

As for blockwork walls, a dimensional survey, a cover meter survey, localised excavation of the foundations and intrusive investigations are likely to be required to estimate the structural strength of the wall.



Class 2 and class 3 containment systems should be constructed as properly reinforced concrete structures built to a water retaining code of practice (see Section 7.2.2).

Box 5.4 *History of reinforced concrete design codes*

The first code for concrete structures was introduced in 1934. This table lists evolution of the key codes of practice.

Date	Design codes
1938	<i>Code of practice for the design and construction of reinforced concrete structures for the storage of liquids</i>
1948	CP 114 <i>The structural use of normal reinforced concrete in buildings</i> (revised version published in 1957, published in metric form as Part 2 in January 1969)
1959	CP 115 <i>The structural use of prestressed concrete in buildings</i>
1960	CP 2007-2 <i>Design and construction of reinforced and prestressed concrete structures for the storage of water and other aqueous liquids</i> (published in metric form in 1970)
1965	CP 116 <i>The structural use of precast concrete</i>
1972	CP 110 <i>Code of practice for the structural use of concrete</i>
1973	Technical memorandum (bridges) BE 1/73 <i>Reinforced concrete highway structures</i> , BE 2/73 <i>Prestressed concrete highway structures</i>
1976	BS 5337 <i>Code of practice for the structural use of concrete for retaining aqueous liquid</i>
1984	BS 5400 <i>Steel, concrete and composite bridges, Part 4, Code of practice for design of concrete bridges</i>
1984	BS 6349 <i>Maritime structures</i>
1985	BS 8110 <i>Structural use of concrete, Part 1 Code of practice for design and construction, Part 2 Code of practice for special circumstances, Part 3 Design charts for singly reinforced beams, doubly reinforced beams and rectangular columns</i>
1987	BS 8007 <i>Code of practice for design of concrete structures for retaining aqueous liquids</i>
1990	BS 5502 <i>Buildings and structures for agriculture</i>
1997	BS 8110 <i>Structural use of concrete, Part 1 Code of practice for design and construction (revised)</i>
2004	BS EN 1992-1-1:2004 (Eurocode 2) <i>Design of concrete structures. General rules and rules for buildings</i>
2004	BS EN 1992-1-2:2004 (Eurocode 2) <i>Design of concrete structures. General rules. Structural fire design</i>
2005	BS EN 1992-2:2005 (Eurocode 2) <i>Design of concrete structures. Concrete bridges. Design and detailing rules</i>
2006	BS EN 1992-3:2006 (Eurocode 2) <i>Design of concrete structures. Liquid retaining and containment structures</i>

Reinforced concrete design

CP 110

CP 110 described as 'the unified code' brought together codes for reinforced, prestressed and precast concrete. From CP 110 to current codes design has been based on specified concrete strengths. CP 110 was published in three parts:

- Part 1 *Design, material and workmanship*
- Part 2 *Design charts for singly reinforced beams, doubly reinforced beams and rectangular columns*
- Part 3 *Design charts for circular columns and prestressed beams*

The design charts in Parts 2 and 3 are based on the guidance given in Part 1. The code introduced the concept of limit state design, partial safety factors being applied to both material properties and loads (ie 'actions' in Eurocode terminology)

Characteristic strengths were specified for high yield reinforcement dependant on bar diameter and method of manufacture (410 N/mm², 425 N/mm² and 460 N/mm²), a partial safety factor of 1.15 was then applied to the characteristic steel strength.

BS 8110

BS 8110 was also published in three parts:

- Part 1 *Code of practice for design and construction.*
- Part 2 *Code of practice for special circumstances.*
- Part 3 *Design charts for singly reinforced beams, doubly reinforced beams and rectangular columns.*

In BS 8110, unlike CP 110, only a single characteristic steel strength of 460 N/mm² was specified for high yield reinforcement. A partial safety factor of 1.15 is applied to the steel strength.

In 1997 BS 8110-1 was revised with the characteristic strength for high yield reinforcement being increased to 500 N/mm².

Eurocode 2

There are four parts to Eurocode 2:

- Part 1-1 *General rules and rules for buildings*
- Part 1-2 *Structural fire design*
- Part 2 *Bridges*
- Part 3 *Liquid-retaining and containment structures*

Part 1-1 is the principal part, which is referenced by the three other parts. There are a number of differences between Eurocode 2 and BS 8110. The key differences are:

- Eurocode 2 is generally laid out to give advice on the basis of phenomena (eg bending, shear) rather than by member types as in BS 8110 (eg beams, slabs, columns).
- Design is based on characteristic cylinder strengths not cube strengths.
- The Eurocode does not provide derived formulae (eg for bending, only the details of the stress block are expressed). This is the traditional European approach, where the application of a Eurocode is expected to be provided in a textbook or similar publication.
- It allow for this type of detail to be provided in non-contradictory complementary information (NCCI) (see *Glossary*).
- Notations and units have been amended.
- The partial factor for steel reinforcement is 1.15. However, the characteristic yield strength of steel that meets the requirements of BS 4449 will be 500 MPa, so overall the effect is negligible.
- Eurocode 2 is applicable for ribbed reinforcement with characteristic yield strengths of 400 to 600 MPa. There is no guidance on plain bar or mild steel reinforcement in the Eurocode, but guidance is given in the background paper to the UK National Annex.
- The effects of geometric imperfection ('notional horizontal loads') are considered in addition to lateral loads.
- Minimum concrete cover is related to bond strength, durability and fire resistance. In addition to the minimum cover an allowance for deviations due to variations in execution (construction) should be included. Eurocode 2 recommends that, for concrete cast against formwork, this is taken as 10 mm, unless the construction is subject to a quality assurance system in which case it could be reduced to 5 mm or even 0 mm where non-conforming members are rejected (eg in a precast yard).
- It is recommended that the nominal cover is stated on the drawings and construction tolerances are given in the specification.
- Higher strengths of concrete are covered by Eurocode 2, up to class C90/105. However, because the characteristics of higher strength concrete are different, some expressions in the Eurocode are adjusted for classes above C50/60.
- The 'variable strut inclination' method is used in Eurocode 2 for the assessment of the shear capacity of a section.
- The punching shear checks are carried out at 2D from the face of the column and for a rectangular column, the perimeter is rounded at the corners.
- Serviceability checks can still be carried out using 'deemed to satisfy' span to effective depth rules similar to BS

8110. However, if a more detailed check is required, Eurocode 2 guidance varies from the rules in BS 8110-2.

- The rules for determining the anchorage and lap lengths are more complex than the simple tables in BS 8110. Eurocode 2 considers the effects of, among other things, the position of bars during concreting, the shape of the bar and cover.

Water retaining structures

CP 2007

The design approach in CP 2007 was based on CP 114 and CP 115, with some modifications. The code gave guidance on the provision of movement joints and details of various types of watertight joint. General guidance was given on construction.

BS 5337

The revised code was published in 1976 and the accompanying handbook was published in 1979. Two different design approaches were given:

- In-line with CP 110 (ie limit state design).
- In-line with CP 114 and CP 115 (permissible stress design as used in CP 2007).

The code defined two conditions for concrete exposed to water with limits to crack widths for each as follows:

Class A: Exposed to moisture or subject to alternate wetting and drying	0.1 mm
Class B: Exposed to continuous or almost continuous contact with liquid	0.2 mm

An alternative method of design was to limit the steel stresses.

BS 5337 required checks on early thermal stresses and required checks on critical reinforcement ratio, where reinforcement exceeds this ratio checks on crack spacing and crack width due to early thermal stresses are required.

BS 8007

The design approach in BS 8007 is to be in full accordance with BS 8110, the option for permissible stress design being removed.

Although the approach for dealing with early thermal effects was as the previous code (BS 5337), it was modified with more detailed guidance given. The equations for calculating crack widths due to flexure were modified to be in-line with BS 8110.

Eurocodes

Part 3 covers additional rules to those in Part 1 for the design of structures constructed from plain or lightly reinforced concrete, reinforced concrete or prestressed concrete for the containment of liquids or granular solids

Principles and application rules are given in Part 3 for the design of those elements of structure, which directly support the stored liquids or materials (ie the directly loaded walls of tanks, reservoirs or silos). Other elements that support these primary elements (for example, the tower structure that supports the tank in a water tower) should be designed according to the provisions of Part 1-1.

Part 3 does not cover:

- structures for the storage of materials at very low or very high temperatures
- structures for the storage of hazardous materials the leakage of which could constitute a major health or safety risk
- the selection and design of liners or coatings and the consequences of the choice of these on the design of the structure
- pressurised vessels
- floating structures
- large dams
- gas tightness.

Also, Part 3 is only valid for stored materials that are permanently at a temperature between -40°C and $+200^{\circ}\text{C}$. For the selection and design of liners or coatings, reference should be made to appropriate documents.

It is recognised that, while this code is specifically concerned with structures for the containment of liquids and granular materials, the clauses covering design for liquid tightness may also be relevant to other types of structure where liquid tightness is required.

In clauses relating to leakage and durability, this code mainly covers aqueous liquids. Where other liquids are stored in direct contact with structural concrete, reference should be made to specialist literature.

5.5.6 Earth bunds (including earth bases with reinforced concrete and blockwork walls) and liners

Unlined earth bunds rely entirely on the impermeability of the soils forming the base and walls to provide containment. In addition, the bund walls have to be designed to withstand the hydrostatic and hydrodynamic pressures should the primary containment fail. There are also a number of facilities comprising concrete wall and earth bases. In these situations the integrity and strength of the walls should be established as discussed in Section 5.5.5.

The impervious nature of soils is clearly a key aspect of ensuring containment. It is common practice to achieve this by providing a one metre depth or thickness of soil with a maximum permeability of $1 \times 10^{-9} \text{ ms}^{-1}$ (see Section 8.2.1).

An investigation is likely to include *in situ* and/or laboratory testing of the soils in the base and walls of the containment facility to establish the permeability of the soils and the ability of the embankment walls to withstand the imposed loading. Advice on commissioning a ground investigation and laboratory testing is provided in Chapter 8. A dimensional survey of the bund walls is also likely to be required.

Class 2 and class 3 earth bunds should be lined and therefore integrity testing (EA, 2009b) of the liner should be completed if there is no leak detection system in place (leak detections systems should generally be provided for a class 3 containment system – see Section 8.12). Beyond inspection for obvious damage to the liner, integrity testing should be completed by a specialist contractor.

EI (2014) provides advice on the design of lining systems (see Chapter 8). Some limited advice on the inspection and maintenance of existing liners can also be found in Chapter 7.

Where there is no liner in place, the decision to install one should be based on reducing risk sufficiently to satisfy the law and discussed with the regulator. For instance, the risk may be adequately mitigated by a sufficient depth of impermeable soil.

5.5.7 Remote secondary containment tanks

Where possible, the particular standard to which the tank was constructed should be established and inspected against the requirements of the standard.

External visual inspection of a secondary containment tank will indicate areas of corrosion, or signs of leakage through joints. However, it may not reveal any leakage through the tank bases.

Severe corrosion can significantly reduce the strength of a tank and its ability to withstand the hydrostatic and hydrodynamic forces imposed upon it should the primary containment fail. Where corrosion is found, specialist advice should be sought to assess if this will significantly impair the performance of the tank and advice sought on suitable repair measures. In extreme cases, the tank may have to be replaced.

Any signs of leakage at joints should be remedied as soon as is practicable.

Advice on the inspection and repair of storage tanks can be found in EEMUA (2003).

5.6 INTEGRITY OF CONTAINMENT SYSTEMS

5.6.1 Joints

Joints in walls and bases are the main source of weakness. The integrity of bunds relies on the performance of the sealant and waterstops. Older bunds from the 1960s to perhaps the 1980s were often constructed using profiled sheet copper across the joints. If present, these would resist chemicals

and heat. However, more recently, PVC waterstops have been used, which may be attacked by heat and chemicals. Several bunds at Buncefield constructed after 1990 and one built in 2000 were constructed without any waterstops.

It is important to establish if the joints in walls and bases are watertight as well as what material, if any, is across the joint. One method is to core down from the top of the wall to confirm if there is a waterstop, or investigate with a borescope inserted into the joint. However, this would probably require removal of any fibreboard and joint sealant.



Figure 5.11
A plated joint (courtesy CH2M Hill, with permission from the Environment Agency)

fire, with a heat-resisting (intumescent) seal bonding the plate to the concrete. Typical plating over and repair details are provided in Chapter 12.

Adjacent wall panels should be orientated such that differential movement caused by thermal expansion during a fire will not cause bursting at the joints. All joints should be fully dowelled and establishing if they have been installed should be included as part of the investigation of the structural strength of the wall. However, it is likely to require an intrusive investigation on at least a sample of joints. Details of appropriate joint details are provided in Appendix A5.

The main function of the sealant is to keep stones out of the joint, so that when it expands thermally, the stones do not spall the edges and stop the joint closing. Their secondary function is to restrict ingress or egress of liquids, but cannot be guaranteed to stop them.

Where waterstops have not been provided, or it is not possible to determine if they were installed during construction, consideration should be given to upgrading the waterproofing at joints. In its simplest form this might involve plating over the joints with sheet steel, anchored to the concrete with provision for thermal expansion, and where these is the risk of



Figure 5.12
A joint that has failed due to thermal expansion because of inadequate dowel provision across the joint. Note also that the tie bolt holes at the foot of the wall also leaked during the incident (courtesy CH2M Hill, with permission from the Environment Agency)



Figure 5.13 A kicker joint (note the use of hydrophilic sealants is not recommend)



Note the pipe is bearing on the formed hole such that the infill concrete or mortar beneath will not form an adequate seal. In addition there is no puddle flange on the pipe.

Figure 5.14 A retrospectively installed pipe penetration. (courtesy CH2M Hill, with permission from the Environment Agency)

Kicker joints where the wall has not been properly tied into the foundation are also one of the main areas for potential failure. Checking for continuity of reinforcement across this joint should be included in the structural investigation. Honeycombing of the concrete is a common problem at the kicker due to poor compaction, and the concrete should be carefully inspected for this defect at this location for signs of leakage, dampness or lime staining.

The typical components of a reinforced concrete wall are shown in Appendix A6.

5.6.2 Penetrations through the containment

The location of all penetrations through the containment should be noted. It is important that each one of these should be tested for watertightness (see Section 5.7.3).

Particular attention should be paid to any grouted-up tie-bolt holes, or sealing of old pipes, cable duct etc. These have been shown to be a particular source of weakness, although they might be difficult to locate on older structures, or where a coating has been applied.

The means of sealing the penetration through the wall is important, as during a fire the seal can fail either because of the high temperatures, or significant loads that can develop due to differential movement where the pipe is anchored by a puddle flange or similar. Advice on sealing pipework, ducts and other penetrations through bund walls is provided in Section 12.7.

Penetrations through a containment wall (apart from overflows in the 'freeboard zone') should be avoided where possible. Those that are necessary should be constructed in accordance with the details provided in Chapter 7.

Where penetrations have been made in existing containment walls, the key issues are the suitability of the waterproofing and provision for movement in the event of a fire. Examples of potentially problematic installations include:

- pipes in over-sized holes
- pipes in over-sized holes with (flammable) gaiters
- pipes cast into the wall that expand and cause the concrete to fail because it is not reinforced and properly tied in
- pipes that have no puddle flanges or have inappropriate flange spacing.

The survey of the facility should include details of all the penetrations and, where possible, details of how they have been installed in the containment wall.



*Figure 5.15
Over time, sealants will detach from the sides of joints and must be regularly inspected and replaced (courtesy CH2M Hill, with permission from the Environment Agency)*

5.7 IN-SERVICE PERFORMANCE

5.7.1 Details of any linings/coating to the containment

Linings to earth bunds are discussed in Section 5.5.6.

Where possible, the details of any protective coating that have been applied to concrete and blockwork walls should be established.

If no details are available and there are no obvious signs of coatings having been applied (penetrative coatings for instance may not be visible) then it should be assumed that none have been applied.



Some surface coatings can have a service life as little as two years. However, if no records are available and the coating is older than two years it should be treated as ineffective, unless its integrity can be demonstrated.

It should be noted that rendering a blockwork wall does not make it suitable for providing class 2 or class 3 containment. Blockwork walls or rendered blockwork walls in class 2 or class 3 situations should either be replaced, or alternative measures put in place such as tertiary containment to reduce risk sufficiently to satisfy the law.

5.7.2 *In situ* load testing

An alternative to confirming the structural strength of a blockwork or reinforced concrete wall through detailed investigation is to complete an *in situ* load test. This requires applying a horizontal force to the wall equivalent to the full hydrostatic pressure plus any dynamic forces that could occur, and monitoring the wall for signs of movement or the development of cracks.

5.7.3 Watertightness

Testing watertightness on anything other than a small bund is likely to be problematic due to the volumes of water required, its subsequent disposal and the ability to detect very small drops in water level attributable to leakage (see Section 6.3.7).

One of the most vulnerable locations for leakage other than at joints is it at the kicker joint. Where rainwater regularly accumulates within a bund, tell-tale signs of leakage at the kicker joints are sometimes apparent on the outside face of the wall.

So, as a minimum, joints and bund penetrations should be tested for watertightness using a local 'limpet dam' or similar. For class 3 containment, a selection of wall panels should be tested in addition to the joints.



Advice on leakage testing joints and wall panels should be sought from a specialist contractor.

5.7.4 Containment tanks

Tanks used to provide secondary or tertiary containment should be inspected at regular intervals informed by manufacturer's recommendations and a risk assessment.

Where it is not possible to visually assess signs of leakage (such as for tanks constructed off the ground) and detection monitoring is not installed, periodic watertightness tests should be completed (see Section 6.3.2).

Items subject to deterioration should have particularly detailed inspections and regular maintenance including:

- welded joints
- bolted and riveted joints
- joint sealants
- laps and seams
- tank bottoms (if accessible)
- protective coatings
- pipe and other connections
- valves
- access hatches
- surfaces subject to corrosion by weathering or aggressive attack.

Welded joints corrode more rapidly than the parent metal, particularly at the base of tanks and at positions subject to exposure and aggressive conditions. Ultrasonic and X-ray techniques can test weld integrity. Site welding repairs must be carried out to the same standard as the original tank specification. Advice on integrity testing of containment tanks can be found in EEMUA (2003).

5.7.5 Leak detection systems (if installed)

Where installed, advice on testing leak detection systems should be sought from the manufacturer and/or installer. An overview of leak detection systems is provided in Section 8.12.

Case study 5.2

A baseline study: compliance and options assessment – bulk fuel tanks and bunds, UK

A tank farm terminal in the north-west of the UK provided storage for around 50 000 tonnes of gasoline, fuel oil and other petroleum products. The CA required that as the site had 'in-scope' gasoline tanks the installation should update their major accident prevention measures with a risk assessment (RA) and assess compliance against the minimum standards for primary, secondary and tertiary containment.

The operator commissioned a consultant to:

- identify representative (credible) release scenarios and complete the RA
- assess compliance of plant, equipment and containment measures against current guidance (HSE, 2009a), CA (2008a) and CIRIA R164)
- identify options for enhancing and upgrading the containment
- implement operational and management (O&M) improvement measures.

The RA required the development of a conceptual source-pathway-receptor model. Sources and release volumes were determined from an assessment of foreseeable (credible) release events. The principal pathway was identified as site drainage and receptors identified through an assessment of the environment setting of the site.

The scope of the compliance and options assessment included:

- primary containment and equipment including tanks, pipelines, flow lines, vent systems etc
- secondary containment comprising the earth bunding to bulk tanks, concrete and masonry bunds to the biofuels and additives tanks and kerbing to the yard, equipment and transfers areas
- tertiary containment including infrastructure drainage, sumps and interceptors, bypass and overspill lagoons, attenuation areas etc
- an asset register was developed for the primary, secondary and tertiary containment based on an examination of engineering drawings and maintenance records together with a site inspection to identify all tanks and equipment. O&M controls were also examined
- the review of the secondary containment highlighted several construction issues, including the use of non fire-resistant mastics in joints. Inspection of the earth bund walls and floor indicated that they generally met with surge and impermeability requirements, however, settlement had compromised bund capacity. A remedial works plan was therefore developed and agreed with the CA to enhance the bund arrangements
- the assessment of the tertiary containment included a review of CCTV surveys and drainage plans and calculation of the required a site-wide containment capacity. The tertiary containment capacity was found to be inadequate for several of the credible scenarios considered. The remedial works plan included measures to enhance tertiary containment arrangements.

5.8 GAP ANALYSIS

The primary aim of the baseline asset survey should be to identify any defects or issues with the secondary containment that would render it ineffective irrespective of class. These defects should be addressed using risk-based prioritisation, or alternative measures put in place, such as tertiary containment, to reduce the risk sufficiently to satisfy the law.

By comparing the results of the baseline asset survey with the specific recommendations for the design and construction of containment systems discussed in Part 3 of this guide, the class of containment provided by the existing installation can be determined.

The class of the existing installation can then be compared to the class required by the risk assessment completed following the guidance in Chapter 2. Should the class of the existing containment fall short of that required by the risk analysis, a gap analysis should be completed to identify the particular shortcomings. Chapter 12 provides advice on the repair and upgrading of existing installations.

Where practicable, these shortcomings should be addressed. However, if it is not considered practical then alternative measures should put in place such as tertiary containment to reduce the risk sufficiently to satisfy the law.

5.9 KEY RECOMMENDATIONS

The key recommendations drawn from this chapter are summarised in Table 5.1.

Table 5.1 **Key recommendations**

Duty holders should prepare an appropriate inspection and maintenance regime for their facilities.
Where one does not exist, each containment facility should be classified using the methodology set out in Chapter 2 of this guide. The classification should be reviewed at least once every five years, or where: <ul style="list-style-type: none">■ there are any modifications made to the primary or secondary containment■ the volume of material in the primary containment is increased■ the nature of the material in the primary containment is changed.
A baseline asset survey of each secondary containment facility should be completed to enable the class to be determined.
A gap analysis should be completed to highlight any shortcomings with the existing secondary containment facility compared to the class required by the use. Where practicable, these shortcomings should be addressed. However, if it is not considered practical then alternative measures should put in place such as tertiary containment to reduce the risk sufficiently to satisfy the law.

6 Introduction to bunds

This chapter provides:

- A definition of a bund (Section 6.1)
- A general overview of design and performance requirements for a bund (Section 6.2)
- Advice on design issues (Section 6.3)
- A summary of general arrangement recommendations (Section 6.4)

6.1 DEFINITION OF BUND

The definition of the term ‘bund’ in the context of this guide is provided in Section 3.2.

“a facility (including walls and a base) built around an area where potentially polluting materials are handled, processed or stored, for the purposes of containing any unintended escape of material from that area until such time as remedial action can be taken. Bunds are usually structurally independent from the primary containment tank”.

As discussed in Chapter 3, the site-wide containment has to retain not just the content of the primary containment but rainfall and, where potentially flammable materials are present firefighting, and cooling water and firefighting foam. These products have to be retained for a minimum of eight days and in some circumstances a considerable period longer while arrangements are made for disposal.

In some sectors of industry the term ‘catchpit’ is used in place of bund. It implies, generally, a small facility, however, as this guide deals with all sizes of facility from small to very large, the term bund is used throughout.

Bunds may be used in a number of different situations, providing local secondary containment at, for example, IBC/drum stores, a small single tank installation, extensive tank farms (see Figure 6.1) and large chemical processing plants. In general where used to provide local containment, bund walls tend to be low in relation to the height of the primary container and for reasons of jetting (see below) and surge (see Section 4.4) there is ideally a large clearance between the two.



Figure 6.1 A bunded tank farm (courtesy Steve Flynn, Rawell Environmental Ltd)

An alternative form of bund, commonly termed a collar bund, is shown in Figure 6.2. Full height collar bunds are built close to the primary vessel, with a height equal to the maximum storage depth of liquid in the primary vessel. Three-quarter collar bunds are not as high but the gap between them and the primary vessel is larger. These are also referred to as ‘cup-tanks’ and are referenced in European Commission (2006). As the annulus between primary and secondary containment is likely to constitute a confined space, a particular issue with collar bunds is that it makes it difficult to inspect the primary containment and visually inspect for signs of leakage. However, detection systems can be installed to monitor for leakage.

It should be noted that while collar bunds may appear similar to double skinned tanks, they differ in that the ‘bund’ element is structurally independent from the primary containment. This is not the case for double skinned tanks and for this reason the second skin of the double skinned tank is not considered to provide secondary containment.

However, where class 1 containment is required, the range of products marketed as ‘integrally bundled tanks’ may be appropriate subject to meeting the requirements set out in Section 7.4.1.

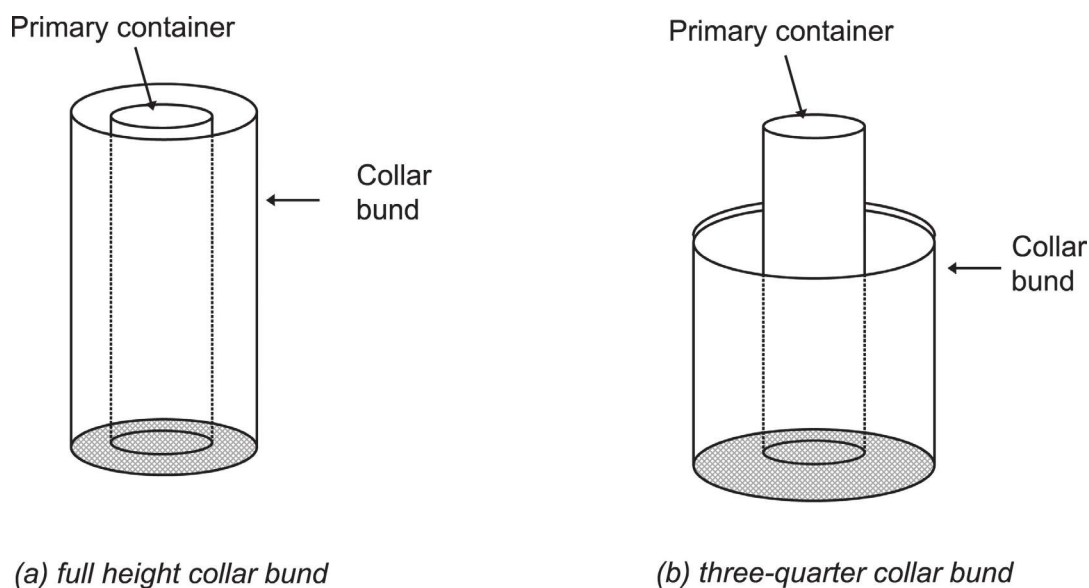

Figure 6.2 Collar bunds

Bunds can also be used in linear form to protect against leaks from pipework. For pipework laid below ground the bund normally takes the form of a covered channel or culvert (although below-ground pipework should be avoided where possible). They can also be used to protect against the failure of primary containment within buildings. The recommendations presented in this section are applicable to each of these situations.

6.2 OVERVIEW OF DESIGN AND PERFORMANCE REQUIREMENTS

This section provides a general overview of the performance requirements for bunds and introduces a number of key design and construction considerations.

The design recommendations differentiate between containment classes 1, 2 and 3, as defined in Chapter 2, by specifying a range of structural design standards and physical arrangements to permit effective performance and monitoring specific to each class.



Specific design and performance criteria for various forms of bund construction are provided Chapters 7 to 9 (see Table 6.1).

Table 6.1 *Forms of bund construction*

Type of construction	Chapter
<i>In situ</i> reinforced concrete and masonry bunds	7
Earth banked containment basins (lagoons), earth bunds and earth floors	8
Secondary containment tanks	9

In general bunds provide a passive defence against escape of pollutant in that they do not require operator intervention in the event of failure of the primary containment. For this reason they are usually seen as the first line of defence against pollution, frequently in combination with remote secondary or tertiary containment systems (see Section 3.2). However, active intervention may be required during some incidents. This may involve managing cooling and firefighting water.

Bunds provide visible protection, which may be both an advantage and a disadvantage. Visibility is an advantage in so far as a bund's superficial condition and fitness for purpose (or alternatively, defects) will be readily apparent. The physical presence of a bund is also a constant reminder to operatives that hazardous or polluting materials are present. However, visibility is a disadvantage in that it can lead to a false sense of security, resulting in the view that other protective measures, including safety and environmental management procedures, need not be taken seriously. For example, small but important changes that could affect the performance of the bund during an incident (breakdown of seals, widening of cracks in winter etc) may go unnoticed on a day to day basis by operations staff.

The monitoring and maintenance of bunds may sometimes be overlooked. However, they should be considered as important assets and a fundamental part of the overall process infrastructure with an inspection and maintenance regime to match. Advice on appropriate inspection and maintenance regimes is provided in Chapter 5.

The Buncefield incident in December 2005 highlighted many shortcomings with the design and construction of the secondary containment facilities at the site that failed leading to a MATTE. The subsequent HSE (2011) report contained a number of recommendations for the design and construction of secondary and tertiary containment that have been reflected in this guide.

The recommendations in this section relate equally to the maintenance, extension and modification of an existing bund as well as the construction of a new containment facility.

In summary, bunds should be designed and constructed to comply with a number of performance criteria that should take into account all credible:

- modes of escape of pollutant from the primary storage vessel
- modes of failure of the bund
- incident scenarios
- loadings
- chemical and physical exposure (particularly fire).

These are discussed in Section 6.3 and summarised in Box 6.8.

Most of the good practice recommendations described in Part 3 apply equally to all classes of containment with restrictions or enhancements for the higher risk classes. Table 6.2 provides an indication of the nature of the different requirements, although it is important that the reader is aware of the context in which they are made, and should refer to the relevant sections in Part 3 of this guide.

Table 6.2 Summary of key design recommendations

Design Issue	Section	Comments
Chapter 4 Containment system capacity		
Fire duration	Box 4.1	All classes
Local secondary containment	4.2.1	All classes
Site-wide capacity	4.3	All classes
Chapter 6 Introduction to bunds (see also Boxes 6.6 and 6.7)		
Height of wall	6.3.1	All classes
Freeboard	Box 6.2	All classes
Proximity to bund wall	6.3.1	Only a consideration for class 2 and class 3
Jetting	6.3.1 and Box 6.3	Only a consideration for class 2 and class 3
Leakage detection from primary containment vessel	6.3.2	Only a consideration for class 3 where primary containment vessel rests on bund floor
Drainage from bunds	6.3.2	No provision for gravity drainage should be made for class 2 and class 3
Pipework	6.3.3	No penetration of the bund wall should be permitted for class 2 and class 3
Impermeability testing	6.3.7	Leak testing of all joints and penetrations upon completion of construction works a requirement of class 2 and class 3
Structural independence	6.3.10	All classes although integrally bunded tanks may be suitable for class 1
Chapter 7 In situ reinforced concrete and masonry bunds		
Competence	7.2.1	Design and construction should be completed by competent personnel
<i>In situ</i> reinforced concrete bunds	7.2.2	Design EN 1992-3:2006 as liquid containing and retaining structure
Joints	7.2.4	Waterbars to be installed in expansions and contraction joints and be resistant to attack by inventory and fire resistant where flammable inventory is stored
Kicker joints	7.2.4	Waterbars installed in kicker joints for class 2 and class 3
Reinforced masonry bunds	7.3.1	Only suitable for class 1 and where inventory is not flammable
Chapter 8 Earth banked containment basins (lagoons), earth bunds and earth floors		
Competence	8.1	Design and construction should be completed by competent personnel
Site investigation	8.1	Detailed site investigation required for all classes to BS EN 1997-2:2007
Design	8.1	Design to be in accordance with BS EN 1997-1:2004
Maximum permeability of soils used for earth embankment construction	8.2.1	$1 \times 10^{-9} \text{ ms}^{-1}$
Earth floors to bunds and lagoons	8.2.1	Equivalent of 1 m depth of soil with a maximum permeability of $1 \times 10^{-9} \text{ ms}^{-1}$
Liner	8.3	Required for class 2 and class 3 unless a significant depth of <i>in situ</i> low permeability soil is present in which case this may be relaxed in consultation with the regulator
Leak detection	8.3	Required for class 3 unless a significant depth of <i>in situ</i> low permeability soil is present in which case this may be relaxed in consultation with the regulator
Chapter 9 Containment tanks (see also Tables 9.1 and 9.2)		
Leak detection	6.3.2	For class 3 leakage detection where tank rests directly on the ground
Chapter 10 Transfer systems (see also Table 10.1)		
Catchment surfacing	10.4	Resistant to inventory and fire plus additional redundancy for higher classes
Catchment construction	10.5	Number of options available including soils, paving, concrete slabs and asphalt and dense bitumen macadam
Transfer system capacity	10.4	Designed to cater for flows arising from a credible scenario

Table 6.2 Summary of key design recommendations (contd)

Pipework and channels	10.4	Designed to be liquid tight and resistant to inventory. Material suitability
Dual purpose systems	10.4	Surface water drainage system should not be used a part of the transfer system
Pumps	10.4	Where the transfer system is reliant on pumping, provision for failure
Monitoring systems	10.4	CCTV surveillance of above ground pipe networks, flow metering of pipe runs, alarm systems and other forms of remote monitoring
Chapter 11 Sacrificial areas and temporary containment		
Sacrificial areas and temporary containment	11.1	Used only as means of mitigating the failure of secondary containment, rather than a replacement for it

6.3 DESIGN CONSIDERATIONS

6.3.1 General arrangement

This section provides:

- bund shape and compartmentation
- height of bund walls
- proximity to primary storage
- jetting.

Bund shape and compartmentation

The shape of a bund should be kept as simple as possible, taking operability requirements into consideration. Complicated footprint shapes tend to lead to difficult structural detailing at corners with a consequent increased risk of failure. The footprint area will be determined by the assessed capacity requirement for the bund discussed in Chapter 4 together with any height limitations for the bund wall. In some circumstances it may be preferable to provide a larger bunded area than the capacity requirement dictates, simply to avoid complicated detailing.

Compartmentation of large bunds (eg bunds around tank farms) into smaller areas means that minor spillages from the primary containment may be confined to a relatively small area, typically the immediate vicinity of a leaking tank. This has several advantages including:

- separation and handling of contents
- a reduction in the risk of escape of polluting material from the bund (because the area it occupies is smaller)
- easier recovery of the material from the bund, and less contamination of that material
- fire control and making the recirculation of firefighting or cooling water easier (greater depth for pick-up for a given volume of water)
- a reduction in the risk of damage to neighbouring tanks and facilities
- maintaining reserve capacity while emptying or during maintenance works.

A typical example of compartmentation is shown in Figure 6.3.



Figure 6.3
A compartmentalised bund (courtesy Seaman Corporation)

It is not necessary for the dividing walls in a bund to be impermeable to the same extent as the bund walls. If the compartmentation is to be designed to be effective during a major incident, the dividing walls should clearly be strong enough to withstand a full hydrostatic head of liquid and surge loads. Care should be taken to ensure that the dividing walls do not compromise the integrity of the bund floor.

Making the height of dividing walls lower than the perimeter walls provides a further level of protection, allowing full bunds to overflow into adjacent compartments.

Height of bund walls

A bund wall should be high enough to retain the contents of the primary storage, with appropriate allowances for rainwater and firefighting water (see Chapter 4). In addition, ‘fixed’ freeboard allowance for firefighting foam and for surge should be provided. These are summarised in Table 6.3.

Table 6.3 Freeboard allowances

Minimum allowance for firefighting agents (foam)	100 mm
Plus surge allowance (in the absence of detailed analysis) for:	
■ <i>in situ</i> reinforced concrete and blockwork bunds	250 mm
■ secondary containment tanks	250 mm
■ earthwork bunds	750 mm

While these considerations dictate the minimum wall height, there are a number of considerations that should be taken into account in deciding the maximum height. Generally bund walls should not exceed 1.5 m in height to:

- enable visual inspection of the bund walls and floor
- facilitate firefighting operations
- ensure relatively easy egress from a bunded area in the event of an emergency
- reduce the risk of the bunded area becoming a confined space by encouraging natural ventilation.

There will be circumstances where, for operational or conflicting safety reasons, it will be necessary for a bund wall to exceed 1.5 m high and in such cases a risk assessment should be completed and the HSE and, if appropriate, the Fire and Rescue Services consulted. It will be essential to provide adequate means of escape for personnel (eg steps or step irons) and to make deep bunds secure against unauthorised access (eg security fencing). The increased risks to operatives from denser than air hazardous vapour accumulations in deeper bunds should also be considered.

Where, due to the constraints on the maximum height of wall, it is not practical to accommodate for the effects of surge in the design of the local secondary containment, an alternative is to provide tertiary containment.

Clearly the height recommendation cannot be applied to collar bunds where the issues to do with firefighting, access by personnel and ventilation are very different and should be addressed specifically for each installation.

Proximity to primary storage

The greater the distance between a bund wall and the primary containment, the less is the risk of failure or bund overflow through:

- surge (see Section 4.4)
- a damaged bund wall falling onto and damaging primary containment (and vice versa)
- jetting.

Given the wide variability of sites, it is not possible to provide definitive recommendations on appropriate minimum distances. However, increasing the distance between the primary containment and the bund will require greater space on a site and can significantly increase the cost of construction.



For class 3 containment the bund wall should be situated so that no structure within the bund is closer to the wall than a distance equal to the structure's own height.

Jetting

The failure of a storage tank through, for example, a rupture or corrosion of the side wall, could result in the escape of a jet of liquid with sufficient force that it projects over the bund wall. This phenomenon is referred to as jetting.

The potential for failure through jetting is minimised by:

- keeping primary storage tanks as low as possible
- increasing the height of the bund wall
- building the bund wall as far away from the tank as necessary.

Box 6.1 provides a method for calculating the minimum height of a bund wall, or the minimum distance from a tank to a bund wall, to ensure that any discharge through jetting is contained within the bund.

Where it is not practical to locate the bund wall so as to contain jetting discharge, baffle plates can be installed.

For exceptionally high primary vessels where there is a risk of fire, following this guidance might result in limiting the effectiveness of firefighting due to the large distances from the bund wall to the vessel. The Fire and Rescue Services should be consulted on this matter.

Box 6.1 Method for calculating bund geometry to prevent jetting

For a small diameter sharp edged discharge orifice, it can be demonstrated that:

$$l^2 = 4 C_v^2 (z-h) (H-z)$$

where C_v = coefficient of velocity

In practice, $C_v \cong 0.99$. Assuming $C_v = 1$ leads to the conservative solution:

$$l^2 = [4(z-h)(H-z)]^{0.5}$$

For a given value of h , it may be shown the l is a maximum when:

$$z = 0.5H + 0.5h$$

which leads to the solution:

$$l_{max} = H-h$$

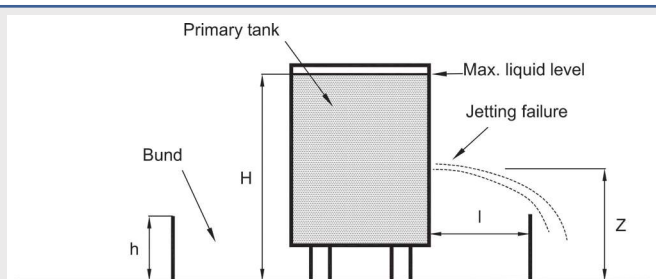

Figure 6.4 shows an example of an installation vulnerable to jetting failure.



Figure 6.4 Example of installation vulnerable to jetting of fuels over the bund wall (courtesy CH2M Hill, with permission from the Environment Agency)

6.3.2 Drainage and leakage detection

This section provides:

- arrangements for drainage within bunds
- detection of leakage from the primary storage vessel within bunds
- drainage from bunds.

Drainage within bunds

Drainage within a bund (or compartment where dividing walls are provided) should:

- collect any liquid that enters the bund (eg rainwater) and provide a means for it to be emptied
- drain spilled material away from the immediate vicinity of the primary tank to another part of the bund where it will be less of a hazard and easier to deal with. This is particularly relevant to larger multi-tank sites where flammable or volatile liquids are stored.

Within small bunds, the floor should be laid to a cross fall to prevent rainwater or leakage from the primary tank from ponding. A minimum fall of one per cent (1 in 100) is recommended as in practice it can be difficult to construct a bund floor to a shallower fall. A sump at a low point in the bund floor will facilitate emptying, but can make construction more difficult. Slot or channel drains across part or the whole width of the bunded area are an alternative to a single sump. These should be designed to be integral to the bund floor construction and not simply cut into an existing slab. Reinforcement cover should be maintained.

For extensive bunded areas it is not normally practicable to provide a fall across the whole site and, in any case, this would be undesirable since it could encourage the spread of escaped liquid. Where extensive bunded areas are compartmented, a sump can be incorporated within each compartment but care should be taken over its construction to ensure that it is not a potential source of leakage.

Where there is the potential for immiscible inventory to be collected in a sump (ie oils) there is a risk that it could be emulsified during pumping allowing it potentially to bypass any downstream interceptors. This should be considered in the design of the drainage disposal system.

Where sumps are provided, and especially if they are to be used to remove firefighting water during an incident, they should be accessible without having to enter the bund. In practice, therefore, sumps should be placed adjacent to bund walls, rather in the centre of the containment area.

Leakage detection from the primary containment

It is important to be able to detect if there is leakage from a primary storage vessel so that remedial action may be taken. If a tank is supported clear of the floor of a bund, any leakage should be relatively easy to detect. However, if the base of the tank rests directly on the bund floor, any leakage is likely to go undetected until there is enough to seep out from beneath the tank and form a visible accumulation in the bund area. Even then, the leakage could be mistaken in some circumstances for rainwater. Also, if there was a defect in the bund floor in the area beneath the primary tank, any leakage could escape to the environment without detection.



The installation of leak detection systems (see Section 8.12) is one of the additional measures that distinguish a class 3 containment from class 1 and class 2 and their installation should therefore be subject to a risk assessment. However, they should be installed in circumstances where there is insufficient clearance between the base of a primary containment and the bund floor to enable visible inspection for class 3 containment systems.

The design of systems for leakage detection from primary containment is outside the scope of this guide, however, some sources of guidance are provided in Box 6.2.

Box 6.2 Leakage detection guidance

- API (2005) *Welded storage tanks for oil storage*: details of a number of systems recommended by API (2005) are provided in Appendix A3)
- Appendix H of BS EN 14015 *Specification for the design and manufacture of site built, vertical, cylindrical, flat-bottomed, above ground, welded, steel tanks for the storage of liquids at ambient temperature and above*
- CDOIF (2013b) *CDOIF guidance – leak detection*: provides guidance on the detection of hydrocarbons following the failure of primary containment)

Inventory (wet stock) reconciliation may also provide a means of detecting leakage. However, reliance on this method of leakage detection should be discussed and agreed with the regulator.

Drainage from bunds

Bunds should not be equipped with means for gravity discharge, even if lockable valves are provided, unless the bund is part of a larger combined system (see Section 3.2) designed to the same class as the bund itself.

Provision should be made to empty rainwater and other liquids from bunds using mobile or fixed pumps.

As it is likely that any rainwater in a bund will become contaminated, unless it is to be drained to an on-site treatment works, or discharged with the appropriate consent to a trade effluent sewer, it should be routinely sampled and analysed so that it may be disposed of in an appropriate manner.

For this reason pumps should only be operated manually following a visual inspection of the bund contents, rather than relying on automatic starting triggered by interface probes (or similar) to detect pollution of accumulated rainwater.

6.3.3 Pipework and associated equipment

Piercing the walls or floor of a bund for pipework, ducts, control cable etc, introduces a source of potential leakage and, with the exception of overflow pipes, should be avoided unless there is no practical alternative.

Where practical, pipework should be routed over the top of the bund wall, rather than through it.

However, where penetrations cannot be avoided, careful detailing of the means of sealing these is essential. This is covered in Chapters 7 and 8 for *in situ* reinforced concrete and blockwork and earthwork bunds respectively.

Where bunds may be required to retain flammable liquids, which are less dense than water, they should incorporate syphon overflow arrangements. In the event of the bund capacity being exceeded (eg by firefighting water) these will prevent burning liquid spilling over and thereby spreading the fire to other parts of the site. In this situation the preferred option is to provide an aqueous phase removal system that does not require piercing the bund wall, however, where this is not possible, the piercing should be within the freeboard zone. The principle is illustrated in Figure 6.5.

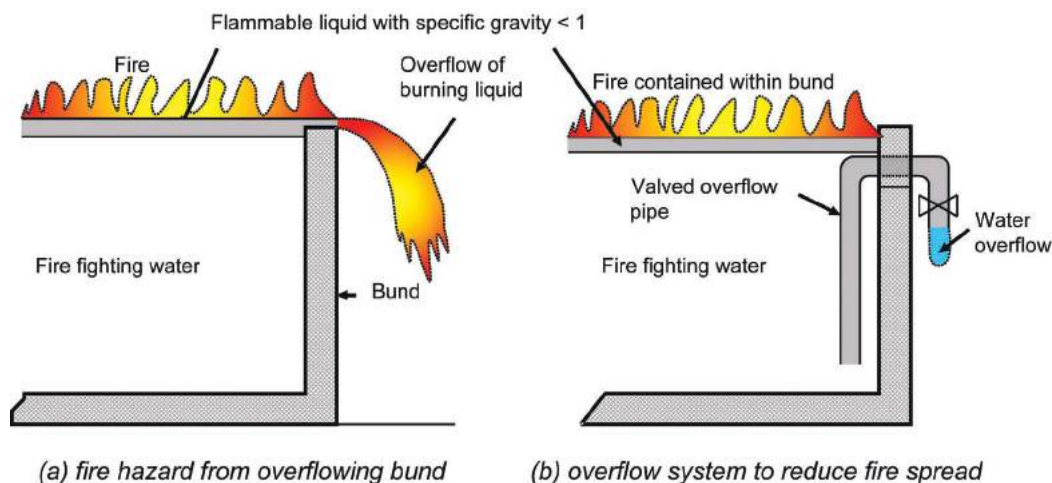

Figure 6.5 Bund overflow arrangements to inhibit spread of fire (courtesy CH2M Hill, with permission from the Environment Agency)

Pipework, pumps, valves and associated equipment are frequently most vulnerable elements to failure and leakage. Where possible, this equipment should be located within the banded area such that the inventory would be contained in the event of failure. However, such equipment should be suitably ignition protected where it may need to operate in a flammable atmosphere and consideration should be given to operability.

An alternative may be to locate pumps in their own separate banded or contained area.

6.3.4 Capacity

Detailed guidance on calculating the required capacity of bunds is presented in Chapter 4.

6.3.5 Retention period

Any liquid that has collected in a bund following an incident should be removed as soon as possible to minimise the risk of subsequent leakage from the bund, or damage to the bund caused by aggressive materials that were part of the inventory.

Where an incident involves only an individual storage tank, or a discrete area of a plant, it may be possible to make provision for emptying the bund and the safe disposal of the contents within a few days. However, in the case of major incidents, emptying and disposal of the contents of a bund may take weeks, even months.

The duration over which the contents may have to be retained has particular implications for the selection of construction materials or the choice of protective coatings where aggressive materials are to be contained.

6.3.6 Impermeability

In most cases it is uneconomic to construct and maintain a bund to be completely impermeable or 'watertight' and the performance specification should ideally include recommended levels of impermeability. The impermeability of a bund is a function of the:

- intrinsic porosity of the material(s) used in its construction (eg concrete, earth, steel)
- way in which the bund is designed and constructed or fabricated using those materials.

However, it would be impracticable to build a bund to a precisely specified level of impermeability and indeed to measure whether that impermeability had been achieved. Consequently, with the exception of soil structures, this guide does not include a performance criterion for impermeability, but prescribes instead a method specification, ie recommends methods of design and construction that if executed in accordance with the specification will result in an adequate level of impermeability.

In practice, where the concern is 'short-term' retention of liquids, it is normally the design detailing of the bund and workmanship during construction (honeycombing, cracks, joint sealing etc) that has the most significant impact on the permeability of the structure, rather than the porosity of the materials themselves.

For bunds that are prefabricated using steel sheet, or built *in situ* using concrete or masonry, adequate impermeability will be achieved provided they are designed and constructed in accordance with the relevant British Standards and codes of practice and the other recommendations given in Chapters 6, 7 and 8 of this guide.

6.3.7 Testing for leakage

For bunds up to 25 m³ capacity and constructed from concrete or masonry it is practical to test for leakage by filling with water using the following recommended methods:

- 1 On a dry day the bund should be filled to brimful capacity (ie until the bund begins to overflow) with water containing a marker dye.
- 2 The bund should be covered (to reduce evaporation) and left for six hours after which there should be no drop in the water level.
- 3 If the bund is found not to be watertight then the source of the leak should be identified and remedied.
- 4 The test should be repeated until the bund is found to be watertight.

However, this will only provide evidence of gross leakage as shown by the example in Box 6.3.

Box 6.3 Impermeability test calculation

- Assume a nominal bund 1.5 m high and 3 m by 5 m in plan area.
- The total internal surface area is 26.5 m².
- Assume a permeability of the walls and base to be $1 \times 10^{-9} \text{ ms}^{-1}$.
- The flow rate through the bund wall and base is $2.65 \times 10^{-8} \text{ m}^3\text{s}^{-1}$.
- Over a period of six hours the loss of water would be $5.72 \times 10^{-4} \text{ m}^3$.
- Over the 15 m² plan area the drop in level would be 0.04 mm and is not practically measurable.

For larger bunds, testing by filling with water becomes increasingly impractical in terms of dealing with both the supply and disposal of the quantity of water involved. However, testing of sections of bund can be completed by installation of a local dam.



Leak testing of all joints and wall penetrations should be completed for class 2 and class 3 bunds upon completion of the construction works.

6.3.8 Strength

Bunds, or proposed modifications to existing bunds, should be designed to withstand:

- The static and dynamic loads that would be exerted by the escape of liquid in the event of the failure of the primary containment.
- The weight of the primary containment when filled with liquid, and any other forces arising from

activities carried out within the bunded area, acting on the base of the bund. The primary storage vessel should not be supported on the bund walls, for example on joists spanning across the top of the walls, as the primary storage vessel and the bund would no longer be structurally independent. If the tank was supported in this way, any impact on the bund may have an adverse effect on it, possibly causing it to fall.

- External actions (for example vehicular impact against the wall).
- Wind loading. This is only likely to be a significant issue for taller (collar) bunds.
- Stresses induced by ground conditions, for example, differential settlement.
- Normal thermal and shrinkage movement of the wall itself.
- Expansion of any embedded components (eg penetrating pipes or other inserts in the wall, heated by solar gain or a fire).
- Additional thermal expansion arising from leakage of warm inventory into the bund and/or its subsequent ignition and burning for several hours.

These loadings and actions are considered below.

Hydrostatic loads

The hydrostatic load should be calculated using the specific gravity of the heaviest liquid that could enter the bund. However, the specific gravity should be taken as not less than 1.0, even where the contained liquid has a lower specific gravity. This is to allow for the possibility that a bund will be filled with firefighting or cooling water.

Depending on the nature of construction, primary storage vessels should be designed to resist floatation should the bund fill with water when they are empty. In some circumstances, it may be necessary to provide adequate foundation to the concrete bund to prevent floatation.

Hydrodynamic loads

The sudden failure of a primary liquid storage tank can result in a wave or surge of liquid across the bunded area. At the same time, because its mass is far less than its liquid contents, the ruptured tank could be propelled in the opposite direction to the main release. There are therefore two loading components to be considered:

- the hydrodynamic force of the wave of liquid hitting the bund wall
- the impact on the bund wall, and possibly other primary tanks, of debris from the ruptured primary tank.

These loads can be difficult to quantify (see Box 6.4).

Box 6.4 *Hydrodynamic forces*

Wilkinson (1991) has reviewed work on model experiments that predict peak hydrodynamic pressures of up to six times the hydrostatic head in collar bunds and later theoretical work that predicts three times hydrostatic head. The impact force of any debris from the damaged primary tank will clearly be heavily dependent on the form of construction of the primary container and the nature of the incident.

3D computational fluid dynamics is an evolving branch of fluid mechanics that may provide a solution to quantifying the hydrodynamic forces that can act on a bund wall following the catastrophic failure of the primary containment. However, the application of CFD in the design of containment systems is beyond the scope of this guide and specialist advice should be sought.

Due to the uncertainty with respect to hydrodynamic loading on shallow bunds, a pragmatic approach should be adopted by assuming that the hydrodynamic forces are taken into account. This can be achieved by designing the walls for a hydrostatic head calculated in relation to the bund height inclusive of the minimum freeboard of 250 mm for dynamic effects. For example, on a typical bund wall designed for 1.3 m depth of liquid, the inclusion of a 250 mm freeboard in the hydrostatic loading calculations results in an increase in pressure of 36 per cent and of 69 per cent in bending moment at the foot of a

wall (see Box 6.5). Where remote secondary and/or tertiary and/or combined containment is in place, ie sole reliance is not being placed on a local secondary bund, the consideration of hydrodynamic forces is less important. However, this is provided there is sufficient site-wide containment constructed to an appropriate class in place to deal with a failure due to hydrodynamic effects.

Box 6.5 Calculation of hydrodynamic loads on bund walls

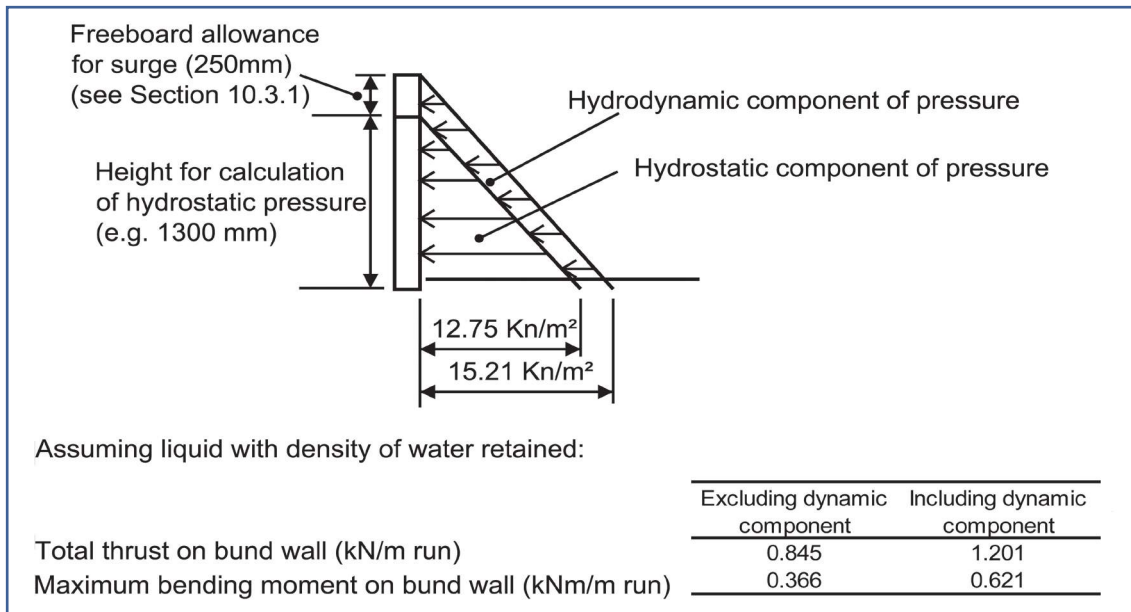

Water from fire and rescue service hoses

The force of water issuing from fire brigade hoses is unlikely to be a significant issue except in the case of earth bunds where this might cause erosion. Earth bunds are considered in Chapter 8.

However, a number of the Fire and Rescue Services are now equipped with pumps that can operate at high pressure. The designer should confirm with the Fire and Rescue Service the equipment that is likely to be deployed during an incident.

External actions (impact etc)

Accidental impact damage from vehicles operating in the vicinity of the bund should be considered. If a risk assessment concludes that there is a significant likelihood that an impact could occur, it may be more appropriate to provide mitigation measures in the form of crash barriers, rather than accommodate in the design of the bund wall. However, crash barriers should not be secured to the bund wall.

Wind loading

Wind is unlikely to be a significant component of loading except for collar bunds, where the recommendations of EN 1991-1-4:2005+A1:2020 should be followed.

Collar bunds should be designed for a 50-year return period loading, making the assumption that the annular space between the primary tank and the bund is empty. Where the annular space is open to the atmosphere, particular attention should be paid to wind suction forces in accordance with the advice contained in BS 6399-2:1997.

Stresses induced by ground condition

Uneven ground bearing pressure can result in differential settlement, which may cause cracking and leakage in bunds. The risk of differential settlement should be assessed by a detailed ground investigation. Following construction, periodic checks should be made to check differential settlement

has not occurred. Advice on the inspection of existing facilities is provided in Chapter 5, and for on-site investigations in Chapter 8.

Shrinkage

Concrete will shrink inducing stress in the walls and slabs as part of the curing process, when temperatures drop, or when exposed to leakage of cold inventory. Catering for shrinkage in the design of concrete bund walls and slabs is considered in Section 7.2.3.

Expansion of embedded components

While not recommended by this guidance, it may be necessary to route pipework and other conduits through the bund wall. Guidance on ensuring a liquid-tight seal around a penetration is provided at Section 7.2.5). This may require the pipe or conduit to be rigidly fixed into the bund wall using a puddle flange or similar. Any loads induced in the pipe or conduit, such as thermal expansion during a fire, would therefore be transferred into the wall.

The potential loads imposed by pipes or conduits anchored into the bund wall should be accounted for in the structural design.

Thermal expansion

When exposed to heat such as from the leakage of warm inventory or a fire, bund walls will expand. Catering for expansion in the design of concrete bund walls and slabs is considered in Section 7.2.3.

6.3.9 Durability

A bund and all its components should have a design life of 50 years (although it may be appropriate to review the design life as part of the design process) and is capable of withstanding:

- 1 Weather:** in most situations a bund wall will be exposed to the weather on both faces and should be designed accordingly. Where bunds are located on industrial sites where corrosive materials are handled, the effects of atmospheric corrosion should also be taken into account.
- 2 Aggressive materials present in the ground:** the most frequent problem is with naturally occurring sulphates, which attack concrete. As a consequence of previous industrial use the ground may be contaminated with other materials, which are harmful to some construction materials. Ground conditions should be assessed as part of a detailed site investigation and appropriate precautions taken. For concrete in contact with the ground, it should be specified in accordance with BS 8500-1:2006+A1:2012
- 3 Disturbance:** durability should include resistance to burrowing animals and tree roots.
- 4 Abrasion:** floors of bunds may be subjected to traffic abrasion where materials are moved around within the bund. Heavily loaded fork lift trucks can be particularly damaging. Surface treatments and finishes should be designed accordingly. Where surfaces have become eroded, crack detection is much more difficult.
- 5 Fire:** a bund and its components should be able to withstand the effects of a fire of the anticipated maximum duration and intensity, without collapsing or leaking. In the absence of any advice from the Fire and Rescue Service (see Box 4.1).
- 6 Material that escapes from the primary storage:** a bund should be able to resist the damage from inventory that escape from the primary storage vessel, without collapsing or leaking, for the specified retention period (a minimum of eight days).

It should be noted that it is all components of the bund construction, including waterstops and joint fillers that should be durable and able to withstand the environmental factors. Recommendations for joints in bund walls and floors are provided in Chapter 7.

To achieve the required durability, it may be necessary to apply a surface protection system to the bund construction. Appendix A4 lists the chemical, fire and weathering resisting properties of a range of protective surface protection systems that are available for protecting concrete and masonry.

6.3.10 Structural independence

To ensure its effectiveness, a bund should be built so that it acts independently of the primary containment and other ancillary structures such as crash barriers etc.

Although, it is not possible to avoid altogether the risk that the failure of the primary container will affect the bund (eg it may simply fall on it), or vice versa, structural independence minimises that risk significantly.

6.3.11 Accessibility

Adequate accessibility is important for three reasons:

- 1 To permit visual monitoring for leakage from the primary containment.
- 2 To allow inspection of the inside face of the bund for signs of deterioration.
- 3 To facilitate maintenance of the bund.

A minimum clearance of 750 mm should be provided to allow access to the inside face of a bund wall, and 600 mm for access to the floor underneath the primary containment. However, larger storage tanks are usually built off a prepared base resting on the bund floor, so access to the bund floor is not possible. In such cases leakage detection measures should be installed to give early warning of leakage from the base of the primary tank. Details of leakage detection systems are given in Section 6.3.2.

Close proximity of the bund wall to the primary containment may render it a confined space, which would hinder regular inspection.

This is particularly important because it is this area of the bund floor that is often most heavily loaded and is therefore most vulnerable to failure. In the absence of leakage detection, chronic leakage through the base of the tank and through a cracked bund could go unnoticed.

6.4 SUMMARY OF GENERAL ARRANGEMENT RECOMMENDATIONS

Table 6.4 summarises the general performance criteria for bunds.

Table 6.4 Performance criteria for bunds

Aspect of performance	Criteria
General arrangement	Size and layout should take account of all credible modes of failure of primary containment.
Drainage and leakage detection	Gravity discharge arrangements from the bund should be avoided where possible unless part of a combined system (see Chapter 3). Leak detection is provided beneath primary containment where there is insufficient clearance to make visual inspections.
Pipework and associated equipment	Penetrations of bund walls avoided where possible. Overflow arrangements to draw off aqueous phase during an incident provided for potentially flammable inventory. Pumps, pipework, valves and associated equipment located within containment.
Capacity	See Chapter 4.
Retention period	Should be designed as a liquid retaining structure.

Table 6.4 Performance criteria for bunds (contd)

Impermeability	For earth structures: not less than the equivalent of 1 m depth of soil with a permeability coefficient of 1×10^{-9} m sec ⁻¹ . In addition lining systems may be required (see Chapter 7). All other forms of construction: 'watertight' or liquid retaining as defined by compliance with British Standards or other recognised standards appropriate to the form and/or materials of construction and containment class.
Strength	Capable of withstanding the static and dynamic loads associated with: <ul style="list-style-type: none"> ■ release of liquid from primary storage tanks ■ release of water from hoses during firefighting operations ■ wind. Bund floor to be capable of withstanding loads from activities within bunded area and the effects of differential settlement.
Durability	Capable of resisting the effects of weather, aggressive ground conditions and abrasion (in each case assuming a durability life of 50 years unless otherwise specified), fire and, depending on the primary storage inventory, corrosive materials (for the duration of the specified retention period).
Structural independence	Bund walls to be structurally independent from the primary containment. Where possible, bund walls to be supported independently from primary containment.
Accessibility	Walls and, where practicable, floors to be sufficiently accessible to permit inspection and for maintenance to be carried out. Where access to parts of the floor is not practicable (eg large tanks sited directly on the bund floor) provision should be made to detect any leakage through the base of primary containment.

Table 6.5 summarises the key performance recommendations for each class of containment.

Table 6.5 Summary of key performance recommendations by class

Recommendation	Containment class		
	Class 2	Class 2	Class 3
a Provide not less than 750 mm clearance between primary tank and bund walls for maintenance access.	Desirable	Recommended	Recommended
b System to detect leakage from primary tank in situations where not practicable to provide clearance between base of tank and bund.	Desirable	Desirable	Recommended
c No structure within bund to be closer than its own height to the bund wall.	Not necessary	Desirable	Recommended
d Pumps*, valves, couplings, delivery nozzles and other items associated with the operation of a primary container to be located inside the bund or within a separately bunded area.	Desirable	Recommended	Recommended
e Penetrations of the bund wall to be avoided.	Desirable	Recommended	Recommended
f No provision for rainwater draw-off via a valved outlet in bund wall.	Desirable	Recommended	Recommended
g Take account of possible jetting failure.	Desirable	Recommended	Recommended
h Take account of surge effects.	Desirable	Desirable	Recommended

Note

* pumps should be selected to be suitably ignition protected where they may need to operate in a flammable atmosphere.

7 *In situ* reinforced concrete and masonry bunds

This chapter provides:

- A brief introduction to *in situ* reinforced concrete and masonry bunds (Section 7.1)
- Advice on the design, detailing and construction of *in situ* reinforced concrete bunds (Section 7.2)
- Advice on the design, detailing and construction of *in situ* reinforced masonry bunds (Section 7.3)
- Advice on prefabricated bund construction (Section 7.4)

7.1 INTRODUCTION

This section gives general guidance on designing and building bunds using reinforced concrete and reinforced masonry. This guidance is equally applicable to the modification or extension of an existing bund as it is to the design and construction of a new facility

This guidance fills the gaps in current structural design code, BS EN 1992-3:2006, whose scope specifically excludes structures containing polluting materials.

The quality of design and construction is fundamental to the integrity of the containment system. It is therefore imperative that any designer, contractor or maintenance works operative engaged to construct, extend or modify a containment system is experienced in designing and constructing to the relevant class of containment. As a minimum, the parties should have a proven history of carrying out the relevant type of work.

All works need to be properly designed, whether it is the construction of a new or replacement bund, the extension or modification of an existing bund, or repair and maintenance work as set out in current standards.

7.2 *IN SITU* REINFORCED CONCRETE BUNDS

7.2.1 Introduction

Designing impermeable, durable and buildable bunds requires careful consideration of the way concrete as a material behaves. It is also important to consider how concrete structures react to loads, temperature changes, drying shrinkage determination due to local atmospheric conditions and differential movement of supports.

There is much general advice available on reinforced concrete structures and many professionals who are experienced in their design and construction. For this reason, this guide focuses on the important performance differences between what is ostensibly a reinforced concrete wall and a water-retaining containment bund that will need to retain liquids for long periods and, where flammable inventory is present, resist a fire.

The differences are to produce reinforced concrete that has specific detailing (eg at construction and movement joints), a narrower structural crack width (eg caused by shrinkage) and is durable.

It is for these reasons that the design of a bund, or modification or extension to an existing bund, should be completed by a competent person experienced in the particular performance requirements

of a containment system set out in this guide. Similarly, the works should be completed by a contractor familiar with the particular methods of construction and workmanship required to deliver a durable, watertight bund (ie designed as a liquid-retaining structure).

It is also good practice for the construction works to be independently verified (ie the works are supervised) to ensure what is built meets the owner/operator's objectives and complies with relevant guidelines and statutory duty (as applicable).

7.2.2 Design approach

Reinforced concrete bunds should be designed and built to comply with the requirements of BS EN 1992-3:2006 and specifically tightness class 1 for all classes of containment together with the specific additional requirements set out in this chapter.



BS EN 1992-3:2006 is concerned with liquid retaining and containment structures. However, where aggressive substances may be present, additional corrosion protection may need to be considered.

BS EN 1992-1-1:2004 provides guidance on the general design principles for reinforced concrete including designing for durability.

7.2.3 Crack control

To achieve an impermeable concrete structure requires cracking in the finished product to be controlled and the elements of the structure to be properly joined. There are two types of crack structural and non-structural, which are discussed in Section 7.1.

Adhering to the design codes will limit predicted structural cracking to acceptable limits. For BS EN 1992-3:2006 tightness class 1, these are specified as 0.2 mm where the ratio of hydrostatic pressure to thickness of the wall is less than or equal to 5 and 0.05 mm where the ratio exceeds 35. For intermediate values of this ratio linear interpolation may be used.

Non-structural cracking occurs in many structures due to:

- stresses due to applied loads
- thermal expansion or contraction
- shrinkage as the concrete dries, hardens and cures
- settlement of the concrete in its wet state
- poorly constructed daywork joints
- differential settlement of the underlying ground
- application of service loads before the concrete has fully cured.

Joints provide the greatest risk of failure, so their number should be minimised as far as is reasonably practicable by increasing the amount of reinforcement and thickness of the slab and walls. An alternative option to minimising the number of joints in floor slabs is to use steel fibre reinforced concrete, or low shrinkage concrete. Advice is provided by Concrete Society (2009a).

7.2.4 Joint detailing

'Movement joint' is the general term for joints intended to open and close. Movement joints intended to allow expansion are formed with a compressible foam spacer and movement joints intended to allow contraction are often formed with a crack inducer to permit shrinkage. There are also construction joints that are not intended to open (eg kicker joint).

The designer needs to consider long-term drying shrinkage movement, thermal movement (summer to winter) and risk of exceptional movement such as in the event of a fire. Movement during a fire can be

minimised through adopting a low thermal expansion design philosophy by, for example, specifying a limestone coarse aggregate.

Movement joints in walls should be formed with de-bonded dowels to prevent differential rotational movement and the failure of seals where there is a fire risk. If joints are provided in the angle of a corner, then when the wall expands in a fire, the thermal expansion can force the walls out of plane and once the fire is extinguished, the cooling, contracting wall may leave a large gap between wall sections.

To prevent out of plane movement during an incident, dowels should be provided across all joints:

- for **expansion joints**, these are de-bonded dowels
- for **contraction joints** and construction joints, the reinforcement is carried through the joint and acts as a dowel.

De-bonded dowels should be provided in base slab joints to prevent differential vertical movement between slabs when subjected to loading and during curing as these movements could put extra (unnecessary) stress on waterstops. Dowels are provided in walls for similar reasons but particularly in the event of a fire where substantial expansion is likely.

Typical joint details are provided in Appendix A5.

Waterstops should be installed within both expansion and contraction joints. Note that the waterstop should be resistant to attack from the primary inventory and where flammable materials are stored, are fire resistant. Stainless steel and/or copper waterstops can be manufactured for such situations as shown by Figure 7.1.

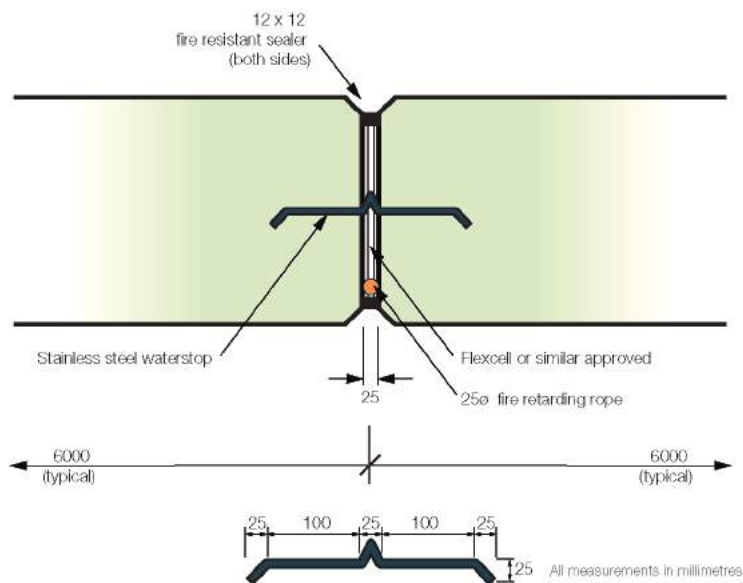

Notes

- 1 Fire retarding rope to be placed on both sides of an internal bund wall.
- 2 Waterstop, rope and fire resistant sealer to be omitted in bundwalls footings.
- 3 Stainless steel for waterbar to be grade 316 and 1.0 mm thick.

Figure 7.1 Stainless steel waterstop joint detail (from HSE, 2009a)

It should be noted that reinforced concrete walls are often constructed off 'kickers', which are construction joints at the base of the wall. Construction joints (the joint between different concrete pours where no movement joint is required) do not normally require waterstops provided the concrete is carefully scabbled and cleaned prior to casting the wall.

However for class 2 and class 3 bunds, waterstops should be included in the kicker joint (see also Section 7.2.12 on the suitability of waterstops).

7.2.5 Penetrations

Where penetrations through bund walls cannot be reasonably avoided, careful detailing is required to ensure they do not provide a leakage pathway during an incident. Large differential movements can occur during a fire and, if a pipe is restrained as it passes through the bund, the forces generated can cause the wall to fail.

An arrangement with a puddle flange cast into the wall inherently provides fire resistance and, if installed correctly, a watertight form of construction. In particular the flange should be adequately tied into the wall by ensuring the concrete is properly compacted around the flange and the reinforcement above the flange should be continuous to the top of the wall. As discussed, if this type of penetration is to be adopted then the potential loads imposed on the bund wall should be considered in the design.

An example puddle flange penetration detail is shown in Figure 7.2.

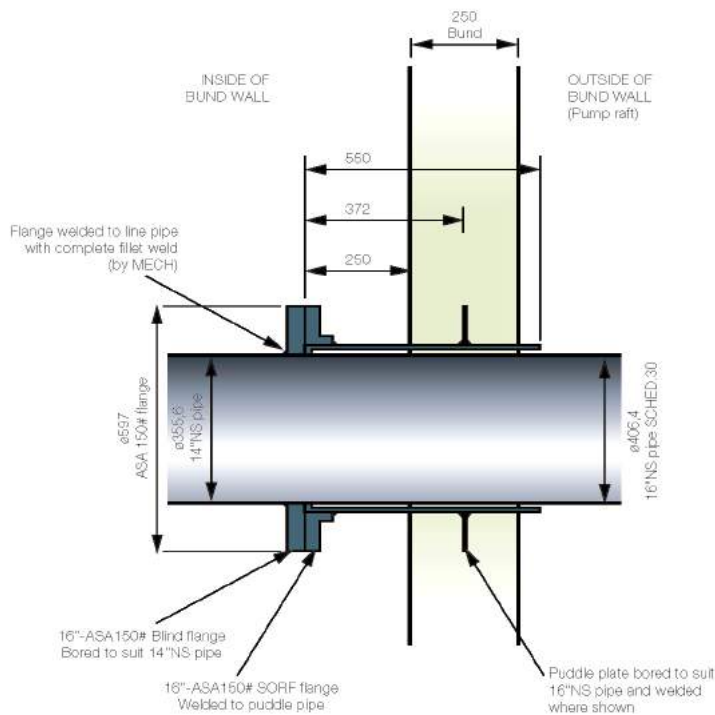

Figure 7.2 Example of a puddle flange penetration (from HSE, 2009a)

Where the pipe or duct is not tied into the wall, a sealed sleeve arrangement will be required to enable the annulus to be adequately sealed. Where potentially flammable inventory is to be stored, metal split fire protection plates should be installed to provide fire protection to the sealant.

An example penetration detail is shown in Figure 7.3.

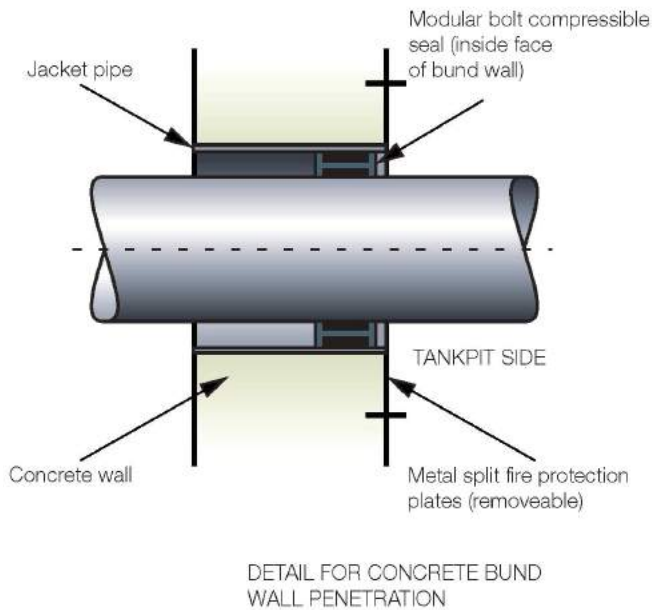

Figure 7.3 Example wall penetration (from HSE, 2009a)

Penetrations through floor of the bund are **not** recommended.

7.2.6 Joint sealants

The sealant is not the primary means of waterproofing a joint, but is intended to assist and to keep debris out of joints. Surface sealing of joints is wholly inadequate for a liquid-retaining structure, as the seal will deteriorate and may fail under hydrostatic pressure or may burn in the event of a fire.

Careful specification and application of joint sealants is necessary to ensure the satisfactory performance of a bund. This is particularly important given the potentially aggressive environment within which they may have to perform, eg from interaction with the hazardous substances that they may need to contain when released from primary containment, or exposure to fire.

There is a wide variety of sealants available. While some are designed for general purpose applications others have been developed for very specialised and specific situations. Sealants differ in physical and chemical composition, methods of application, durability and cost. Guidance on sealant selection and application is given in BS EN ISO 11600:2003+A1:2011, BS 6213:2000 and CIRIA (1991).

To ensure satisfactory performance of sealants, the manufacturers' instructions should be followed closely.

It should be noted that sealants have a finite life and therefore the planned maintenance for the bund should include their replacement approximately every 10 years. Advice on the lifetime of the sealant should be sought from the manufacture. Any existing sealant will need to be raked out back to sound material, which is then cleaned thoroughly, primed and then new sealant applied.

7.2.7 Surface protection systems

Surface protection systems are discussed in Section 12.2.3.

7.2.8 Concrete production

Ready mixed concrete should be obtained from suppliers who are registered with the Quality Scheme for Ready Mix Concrete (QSRMC) (see *Websites* box at the end of this chapter). This provides a quality management system and product conformity certification for the design, production and supply of ready mixed concrete.

Batching should not be completed on site as it will not fall within the QSRMC unless it is a fully certified plant operation to BS EN ISO 9001:2008.

Concrete should be specified to BS EN 206-1:2000 and BS 8500-1:2006+A1:2012. In addition, the guidance of BS EN 1992-3:2006 should be allowed with respect to cement content requirements.

7.2.9 Shuttering and formwork

Shuttering for bund walls should be robust and adequately secured by means of braces and props. Avoid through-wall tie-bolt holes when constructing concrete bund walls, or where this is not possible, use proprietary 'leave-in-place' flanged or water-stopped versions (see Figure 7.4).



Figure 7.4 A 'leave in place' flanged tie bar

Formwork should be erected such that:

- any joints are impervious
- it will withstand the hydrostatic pressure of the fresh concrete
- it forms a seal against previous concrete construction (kickers etc).

This will prevent the loss of fines during casting that can lead to honeycombed, porous concrete.

7.2.10 Reinforcement fixing

Reinforcement should be fixed accurately and securely to prevent it being displaced while the concrete is being placed and compacted. Displacement can result in serious structural weakening and/or durability problems. For example, increasing the reinforcement cover compared to that designed can significantly reduce the structural strength of a wall in bending. Conversely, reducing the cover will lead to reduced protection to the reinforcement, so shortening their life by accelerating corrosion.

7.2.11 Slip membrane

A slip membrane of 1000-gauge polyethylene or similar material should be laid beneath bund floor slabs to:

- prevent loss of cement and fines from the concrete mix
- provide a smooth and regular slip surface to minimise resistance to thermal and shrinkage movements of the bund floor.

The membrane should be laid on minimum 50 mm sand blinding to prevent puncture by the underlying sub-base or formation. Adjacent sheets should be joined using either taped or double folded laps to make them waterproof. It should be noted that the membrane should not be considered a 'waterproof membrane' in terms of the containment system unless it is specifically designed to fulfil this role.

Where the bund floor is to be designed as a fully restrained slab (with no provision for movement around the perimeter), using a slip plane should be avoided. Instead, the bund floor should be cast on top of

a lean-mix concrete blinding laid on top of a prepared sub-grade without a polyethylene membrane to ensure the bund floor, blinding layer and subgrade act monolithically.

In general, the workmanship should follow the recommendations by Concrete Society (2009a).

7.2.12 Waterstops and joints

For waterstops to be effective, they should be positioned carefully, joined using the methods specified by the supplier and the concrete thoroughly compacted around them. A poorly installed waterstop can result in a greater leakage through a joint than if one had not been installed in the first place.

Hydrophilic waterstops are used widely in reinforced concrete construction. However, these should not be used for bunds as they do not work with non-aqueous liquids and are not particularly effective in conditions where the joint is generally dry, with only occasional aqueous wetting, as is the case with a bund wall or floor.



Note
The thickening of the edge of the slab for the ring beam

Figure 7.5 Waterstop tied into reinforcement cage at the kicker and rear face waterstops at the planned slab joints (courtesy H W Coates Ltd)

7.2.13 Concrete placing and compaction

The general advice contained in Concrete Society (2008) should be followed when placing and compacting concrete. It also provides advice in concreting in hot and cold weather.

It is essential that the concrete is thoroughly compacted to remove any air pockets and small air bubbles if the desired design strength, impermeability and durability of the bund are to be achieved. It is important also to avoid over-compaction, particularly in bund floor construction as this can lead to segregation.

The concrete should be placed as quickly as possible. Double-handling should be avoided to minimise segregation.

When casting slabs, the passage of wind over the surface will cause shrinkage that might lead to cracking and provision should be made to prevent this with wind breaks. Surfaces should be sheltered from direct hot sunlight with covers (eg polythene), which will also aid curing.

The concrete producer can add water to ensure the correct consistency is achieved, but once supplied, the contractor should not add any extra water to the mix and should ensure all forms are clean and free from standing water in them.

Walls should be cast full height (above the 'kicker' joint) in one pour to avoid horizontal joints that can provide a potential leakage path.

7.2.14 Concrete finishing

In most situations, bund floor slabs should be power float finished or finished with a vibrating beam/razorback and bull float to close surface pores and cracks. Consideration should also be given to a final finish with a broom to give a slight anti-slip texture.

7.2.15 Concrete curing

Immediately after compaction, concrete slabs and the cast tops of the walls should be covered with polythene, ideally a tent arrangement over slabs or with wet hessian covered by polythene sheeting. Alternatively a curing membrane may be applied. Over-rapid drying results in a poor-quality surface with reduced strength and durability and can lead to plastic shrinkage cracking (see Figure 7.6).



Figure 7.6 Plastic shrinkage cracks (courtesy Concrete Society)

Curing should be maintained for a period of seven days. For walls, formwork should be struck and then sheet protection such as polythene should be applied to cure the concrete effectively. Loading a slab before the concrete has fully cured can lead to deformation and cracking.

7.2.16 Typical reinforced concrete bund details

Typical details for a reinforced concrete bund are provided in Appendix A6. These are for illustrative purposes only and should not be used as the basis for a detailed containment bund design.

7.3 REINFORCED MASONRY BUNDS

7.3.1 Introduction

This section gives guidance on designing bunds using reinforced masonry (blockwork and brickwork). Unreinforced masonry should not be used for bund construction because of its susceptibility to thermal and shrinkage cracking and vulnerability to impact damage.

The use of reinforced blockwork should be restricted to bunds for class 1 containment only as, even if lined with waterproof render, it is unlikely to resist fire without significant thermal expansion, cracking and possible failure. Reinforced brickwork, other than grouted cavity construction should not be used for bunds.

Blockwork bund walls should be designed in accordance with BS EN 1996-1-1:2005+A1:2012.



7.3.2 Forms of construction

Forms of masonry wall construction are set out in Table 7.1 and typical details for a reinforced masonry bund are provided in Appendix A8. These are for illustrative purposes only and should not be used as the basis for a detailed containment bund design.



Given the relatively large amount of thermal and drying shrinkage movement that occurs in blockwork walls it is necessary to incorporate movement joints with waterstops at approximately six metre intervals. Such movement joints are very difficult to seal effectively and blockwork should not be used for any class of bund other than for small bunds, ie where the walls will be less than six metres long.

The inside face of a blockwork bund should be rendered with a sand/cement render. Further protective coatings may then be required depending on the material stored in the primary containment.

Table 7.1 Forms of masonry wall construction (for class 1 only unless otherwise stated)

Form of construction		Suitability for bund wall construction
a	Structural concrete blockwork with vertical reinforcement in filled cores.	Susceptible to thermal and drying shrinkage.
b	Concrete blockwork used as facing skin or cladding for reinforced concrete bund wall.	Suitable for all classes provided that the reinforced concrete wall is properly designed and constructed. Provides protection to concrete in the event of fire.
c	Structural brickwork with reinforcement in bed joints only.	Should not be used. Insufficient strength to withstand lateral loads from liquid in the event of an incident. Poor resistance to impact damage. Susceptible to thermal and shrinkage cracking.
d	Brickwork as facing skin as in (b).	Suitable for all classes as (b).
e	Grouted cavity brickwork (brickwork acts as permanent shuttering for reinforced concrete (see Figure 7.7).	Suitable for all classes provided reinforced concrete in cavity is properly designed. Brickwork skin provides additional protection to concrete.
f	Pocket wall, Quetta bond wall and vertical slot walls in blockwork or brickwork (see Figure 7.7).	May be suitable subject to incorporation of sufficient reinforcement and provision of adequate concrete cover.

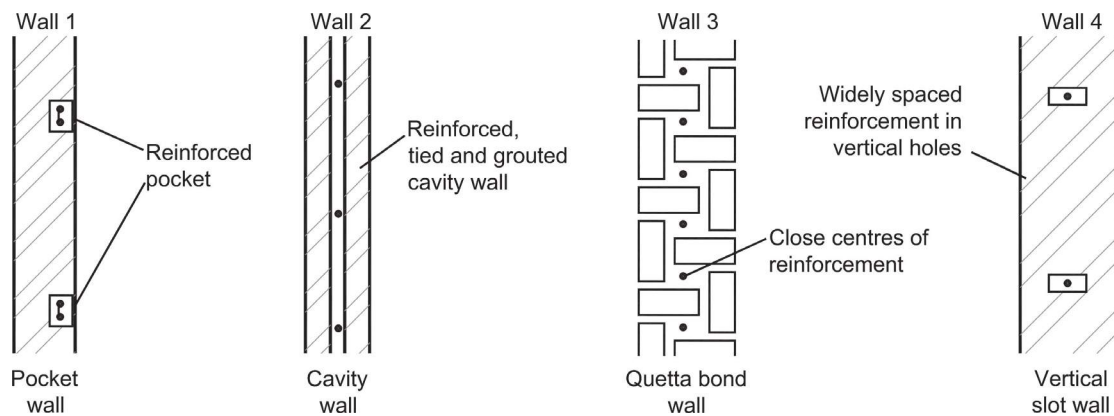

Figure 7.7 Composite masonry and concrete wall construction

7.4 PREFABRICATED BUNDS

7.4.1 Introduction

The performance criteria developed for bunds in this guide excludes double-skinned tanks on the grounds that the inner and outer containers, which make up the items, are structurally joined or interdependent. In general, these are primary tanks with a second 'skin' placed around it and a very small gap between the two.

However, where class 1 containment is required the range of products marketed ‘integrally bundled tanks’, are considered acceptable as long as they provide sufficient containment to comply with the capacity requirements set out in Chapter 4.

SEPA (2014) advises that:

“Some proprietary integrally bundled tank systems take the volume of the primary tank into account when calculating secondary containment capacity, and provide additional secondary containment capacity of less than 110 per cent of actual primary tank capacity. This is generally acceptable where, if there was a leak in the primary container, inventory could find its own level in both containers. In this instance the primary container contributes to the total containment capacity, which as long as it totals 110 per cent, will be acceptable.”

The construction of bunds or containment tanks with precast concrete segments (multi-straked tanks) is discussed at Section 9.2.8.

The following guidance is therefore concerned solely with prefabricated bunds that conform to the performance criteria set out in Box 6.8.

7.4.2 General description

A prefabricated bund is a prefabricated tank, usually constructed from steel or plastics, inside which the primary container is placed. One-piece prefabricated bunds are available in capacities up to 100 m³, with the maximum size usually being dictated by the difficulties in transportation.

Larger bunds may be constructed on site by joining together two or more prefabricated sections. A lid (or roof) may be provided to keep out rainwater.

7.4.3 Specification and procurement

Prefabricated tanks are manufactured items and their detailed design is outside the scope of this guide. The following information is limited to general guidance.

Prefabricated bunds should comply with the capacity recommendations given in Chapter 6. The requirement for access for inspection, or alternatively provision for leakage detection, are described earlier in this chapter.

Prefabricated tanks used as bunds should be designed in accordance with the relevant material structural codes to withstand the hydrostatic and hydrodynamic forces that would result from a failure of the primary containment. Where there are no relevant structural codes a prospective purchaser should require the supplier to provide evidence, in the form of independently certificated test results or analyses. This is to ensure that the product is capable of withstanding the forces resulting from a failure of the primary storage vessel (see Section 6.3.8) and can provide the service life required by the operator.

A prefabricated bund should not rely on a structural link with the primary tank for its stability.

7.5 INSTALLATION

The installation requirements for prefabricated bunds are product and site-specific. Suppliers should provide the necessary installation instructions to cover a specified range of site situations, and guidance on how to cater for site conditions that fall outside that range.

Installation instructions should cover at least the following aspects of delivery and installation:

- loading and unloading
- support requirements
- any ancillary protection requirements

- health and safety requirements and need for notices
- commissioning.

7.5.1 Testing

Where prefabricated bunds are constructed under factory-controlled conditions in accordance with an appropriate British Standard or code of practice (for example, BS 799-5:2010 for tank manufacture), testing for leakage should be in accordance with those standards or codes. Where this does not apply, or where the relevant standards or codes do not include provision for leakage testing, prefabricated bunds should be tested in the same manner as described for *in situ* bunds (Section 6.3.7).

7.5.2 Maintenance

The supplier of a prefabricated bund should provide full instructions on inspection and maintenance covering at least the following:

- details of any finishes or other protective measures to be applied at time of installation
- frequency of inspection
- preventative routine maintenance requirements
- damage repair.

Prefabricated bunds should be inspected regularly for signs of damage, deterioration or general wear, and to ensure that nothing has collected in unroofed or uncovered bunds to reduce their effective capacity.

Websites

Quality Scheme for Ready Mix Concrete (QSRMC/CPC): www.qsrmc.co.uk

Accessed 29 May 2014

8 Earth banked containment basins (lagoons), earth bunds and earth floors

This chapter provides:

- An introduction to earth bunds and lagoons (Section 8.1)
- Advice on appropriate design criteria for lagoons and earth bunds (Section 8.2)
- The measures that distinguish the three classes of construction for lagoons and earth bunds (Section 8.3)
- Determining the required capacity (with reference to Chapter 4) and siting of lagoons in relation to sensitive receptors (Sections 8.4 and 8.5)
- Advice on completing a ground investigation and the permeability requirements for lagoons and earth bunds (Sections 8.6 and 8.7)
- Advice on general design and construction issues, lining systems and anchorage and protection of liners, pipe entries through embankment walls and leakage detection systems (Sections 8.8 to 8.12)
- Advice on maintenance (Section 8.13)

8.1 INTRODUCTION

Where the site topography, land availability and the ground and soil conditions are suitable, earth embankments can provide a cost effective means of providing both local secondary containment (earth bunds) and remote secondary, tertiary or combined containment basins (lagoons) as shown by Figures 8.1 to 8.3. Bunds are also formed with concrete or masonry walls with earth floors.



Figure 8.1 Large earth embankment bund (in service) (courtesy Oil Spill Solutions Ltd)

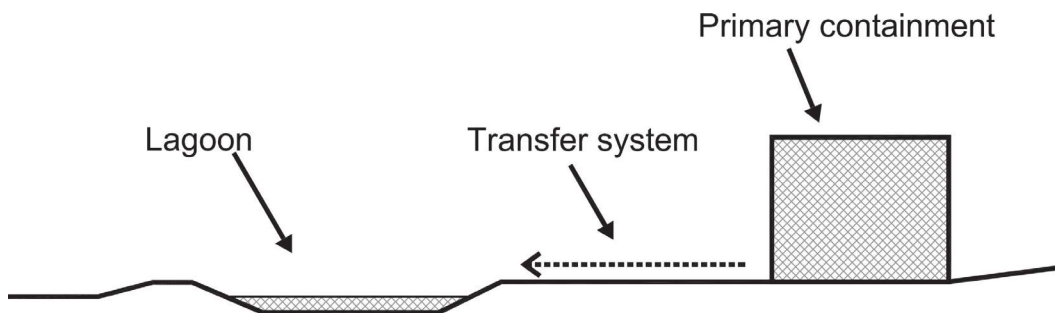

Figure 8.2 Earth banked lagoons for 'local' containment

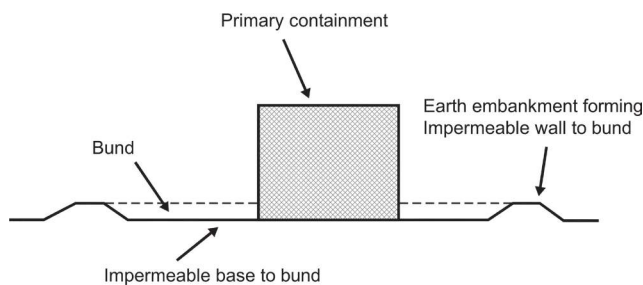

Figure 8.3 Earth banked lagoons for 'remote' containment



Earth bunds and lagoons may be constructed either above or below the surrounding ground level and formation level is often determined by the economic advantage of balancing cut and fill. Depending on the soil type, but particularly its impermeability and stability, and the environmental sensitivity of the site (resulting in a site classification – see Chapter 2), they may need to be lined using an impermeable membrane or other suitable liner.

It is expected that few sites will be able to rely on the use of *in situ* soils and it is more likely that soils will need to be imported and reworked, with or without admixtures, particularly where they are to be used for bund walls.

This chapter relates principally to the formation of containment systems from earth embankment sides with earth floors at existing ground level (bunds) or below ground level (often referred to as 'lagoons'). It also applies to the earth floor of a bund where the containment walls are formed in reinforced concrete or blockwork. Recommendations on reinforced concrete walls are provided in Chapter 7 and a typical construction detail is provided in Appendix A8.

This section sets out design criteria with the aim of achieving containment systems that are of an equivalent standard to those constructed using concrete and other conventional construction materials.

The properties of soils can vary significantly, both spatially, seasonally (or as a result of antecedent weather conditions) and over time. The permeability can vary by several orders of magnitude within a matter of metres for what may appear a homogeneous soil, and changes in moisture content can have a marked effect on stability and bearing capacity.

Earth bunds and earth floors should be designed in accordance with the requirements specified in BS EN 1997-1:2004 and the ground investigation executed in accordance with BS EN 1997-2:2007. A general introduction to Eurocode 7 is provided in Driscoll *et al* (2008).

BS EN 1997 explicitly states that appropriately qualified and experienced personnel are to provide the input data for geotechnical designs and that only they should carry out the design and ground investigations.



The variability and relative unpredictability of soil as a construction material, and the absence of recognised design standards, makes differentiation between classes 1, 2 and 3 of construction more difficult than it is with other forms of construction. A simple approach to classification has been adopted Section 8.3.

8.2 DESIGN CRITERIA FOR LAGOONS AND EARTH BUNDS

This section sets out appropriate design criteria and ways these should be satisfied. The essential requirements are an acceptable level of impermeability, stability and durability.

8.2.1 Soil permeability limits

It is not possible to achieve a completely impermeable soil structure and there will be some seepage from any unlined lagoon, however carefully constructed.

Based on industry guidelines drawn from the design of landfill containment systems, it is accepted good practice that a minimum one metre thickness of soil with a permeability of no greater than $1 \times 10^{-9} \text{ ms}^{-1}$ should be provided. This is particularly important beneath a tank or tank floor where any leakage may go undetected for extended periods. Further advice is provided in CA (2008b).

The same performance requirements could be achieved by providing a less thick layer of less permeable material.

Typical values for the permeability of soils are shown in Table 8.1 and it is evident from this that only soils with a high clay content will give the required level of impermeability. It should be noted that there are many instances of naturally occurring clays that do not meet this recommended performance requirement, or contain lenses or bands of higher permeability silts and sands.

Table 8.1 Permeability of soils by broad category

Soil type	Coefficient of permeability (ms^{-1})	Relative permeability
Coarse gravel	Exceeds 10^{-3}	High
Sand	10^{-3} to 10^{-7}	Medium to low
Silt	10^{-7} to 10^{-9}	Very low
Clay	Less than 10^{-9}	Impervious
Concrete (for comparison)	10^{-10} to 10^{-12}	Impervious

8.2.2 STABILITY

Lagoons and bund embankments should be designed and constructed to meet the following stability criteria:

- embankments to be accessible to, and capable of, withstanding the loads from machinery and vehicles used during maintenance and emptying operations
- embankments to remain stable during rapid drawdown and filling
- embankments to be capable of withstanding the erosion from heavy rainfall
- embankments to be capable of withstanding erosion by any firefighting water likely to be used in the event of an incident, or wave action due to wind
- no reliance should be placed on short-life (defined here as less than 20 years) impermeable liners to provide or improve embankment stability (unless the lifetime of the facility is less than 20 years)
- the design should include measures to prevent the actions of burrowing animals
- an appropriate factor of safety should be included. These are described in BS EN 1997-1:2004 as ‘partial factors’ and the choice of value depends on whether the particular parameter was directly observed (*ie in situ* or laboratory testing) or a characteristic value is being used.

8.2.3 Durability

Lagoons and earth bunds should be designed for a durability life of 20 years subject to normal routine maintenance. In assessing durability life, it should be assumed that the lagoon or earth bund remains empty for the whole period and that the earthworks and any lining systems incorporated in the works will be exposed to the weather.

Lagoons that form part of the site-wide containment (local secondary or tertiary – see Section 3.2) should not be used as permanent storage or for balancing purposes (unless for the recirculation of firefighting water) as this would reduce their effective capacity.

8.3 CLASSIFICATION OF CONTAINMENT



There are no British Standards or codes of practice that explicitly cover earth structures for retaining liquids, and therefore it is not possible to define the differences between class 1, class 2 and class 3 containment construction in terms of modifications to 'normal' standards.

However reference to BS EN 1997-1:2004 and BS 6031:2009 should be made in the planning, design and construction of the works. In particular Section 7 of BS 6031:2009 covers the design of earthworks and the stability of slopes.

Nevertheless, it is still important to try to differentiate between the classes to reflect the range of environmental sensitivities that exist and thereby ensure that the most appropriate measures are put in place at each site. This is discussed as follows.



Where the soil conditions are favourable, or can be engineered to be so, in general class 1 containment can be satisfactorily achieved by an unlined lagoon. However, extra precautions should be taken for class 2 and class 3 containment. For a class 2 lagoon the floor and banks should be lined with a suitable impermeable liner. For a class 3 lagoon, the same as class 2 plus a suitable leakage detection system (see Section 8.12) to allow periodic monitoring of the integrity of the containment.

These general requirements are illustrated in Figure 8.4.



However, in some circumstances, it may be possible to demonstrate that the risk can be reduced sufficiently to satisfy the law for class 2 and class 3 containment systems without the provision of a liner. This might be, for instance, when the site is underlain by several metres of homogeneous impermeable clay. This will be a matter for agreement with the regulator.

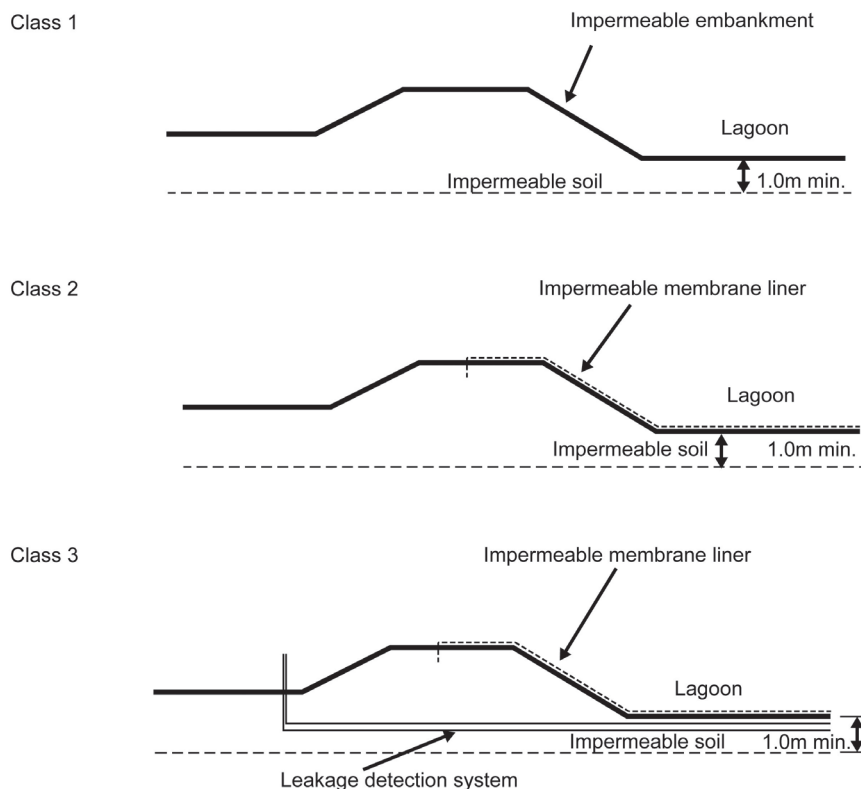

Figure 8.4 Classification of lagoons

It should be stressed that in all cases the ground and soil conditions should comply with the impermeability, stability and durability criteria set out previously. Where impermeable linings and leakage detection systems are required these are as an **additional** level of protection and **not** to compensate for inadequate ground and soil conditions.

8.4 CAPACITY

The capacity of a lagoon or earth bund should be calculated in accordance with the recommendations given in Chapter 4.

As noted in Section 4.4, the sloping internal face of an earth embankment has been shown to increase the risk of overtopping by surge, and that earth embankments are more prone to settlement and erosion than a concrete or blockwork bund wall.

Therefore a minimum freeboard of 750 mm should be provided for earth embankment bund walls (see Box 4.5).

8.5 LOCATION OF LAGOONS IN RELATION TO RECEPTORS

In the absence of specific controls governing the siting of containment lagoons (secondary or tertiary – see Section 3.2) in relation to watercourse or the sea and subject to obtaining the regulator's approval for a particular site, the requirements included in the Water Resources (Control of Pollution) (Silage, Slurry and Agricultural Fuel Oil) (England) (SSAFO) Regulations 2010 should be adopted. These are currently (2014) being revised.

Schedule 1, Regulation 6 states:

“No part of the silo, its effluent tank or channels or any associated pipes shall be situated within 10 metres of any inland or coastal waters which silage effluent could enter if it were to escape.”

In addition lagoons (see Section 3.2) should not be sited within 50 m of a borehole used to abstract water. Details of licenced abstractions can be obtained from the regulators.

8.6 GROUND INVESTIGATION

BS EN 1997-2:2007 makes compulsory the provision of a ground investigation report as part of the geotechnical design process. Such an investigation survey will normally involve a desk study, reconnaissance of the site and an investigation of the soils. The ground investigation should be managed by a suitably qualified person (normally a chartered geotechnical engineer).

8.6.1 Desk study

The importance of carrying out a thorough desk study in the early stages of planning the works cannot be overstated. A lagoon or earth banked bund may cover a large site area and it is essential that any features, which could affect performance, are identified. A study of maps and plans of the site, particularly older documents, and discussions with the local authority and local utility providers may reveal features, which are no longer apparent, such as infilled drains and wells, dried up streams and old building lines.

In mining areas, enquiries should be made to the Coal Authority about past and present mining operations and any existing, or predicted, problems with subsidence locally (see *Websites* box at the end of this chapter).

Geological maps and borehole records can be obtained from the British Geological Survey (see *Websites* box).

8.6.2 Site reconnaissance

Site reconnaissance entails a methodical physical inspection of the site to identify features that could cause construction difficulties or longer-term reliability problems.

Topography is an important factor, not only in terms of facilitating drainage into the lagoon or bund, and other operational considerations, but also in relation to the possibility of slope instability evidenced by sloping walls, trees and fences. This can occur on slopes as shallow as 1 in 10. Abrupt changes in local topography may indicate changes in ground conditions.

Vegetation is an important indicator of soil types and groundwater levels. Reeds and willows, for example, indicate a high water table (which could make a lined lagoon impracticable), whereas bracken and gorse usually indicate a well-drained soil with a low water table. As with topography, abrupt changes in vegetation may mean significant changes in ground characteristics.

8.6.3 Soils investigation

The two most important characteristics of the soil that govern whether *in situ* soil can be used (with or without modification, eg by incorporation of admixtures, or compaction) are:

- 1 **Permeability:** can a one metre thick layer of soil with a maximum permeability of $1 \times 10^{-9} \text{ ms}^{-1}$ be reasonably achieved?
- 2 **Stability:** the soil should remain stable under changing conditions (particularly moisture content changes) and, when formed into an embankment, meet the requirements of Section 7.2.2.

The physical properties of the soils are generally determined by the recovery of samples for laboratory testing as part of the ground investigation, although some testing is completed *in situ*. The ground investigation should be informed by the desk study and site reconnaissance to ensure that representative samples are obtained across the site. The design of the site investigation to include the location of boreholes and/or trial pits and the suite of *in situ* and laboratory testing required should be completed by competent personnel.

Assessing the suitability of soils to meet the characteristics requires interpretation of the ground investigation and laboratory testing data, and should also be completed by competent personnel.

8.7 SOIL PERMEABILITY

8.7.1 Permeability assessment

The permeability of the soils underlying the site should either be established *in situ* in accordance with BS 5930:1999 or by the laboratory testing of a sample in accordance with BS 1377-5:1990.

It should be noted that the testing methods recommended by these two British Standards are progressively being superseded by BS EN 1997-2:2007.

It will be important when designing the site investigation to ensure sufficient tests are completed to provide a representative estimate of the permeability across the site and for the full depth of soils, ie a minimum of one metre below the proposed floor level of the bund with samples taken at varying depths. Tests should be completed on the material that is to be used to form the walls and floor of the containment area.

Any exploratory holes excavated as part of the ground investigation should be reinstated to ensure they do not provide a potential pathway to groundwaters. Advice for sealing boreholes is provided in EA (2012).

Generally, experience has shown that the most suitable soils for constructing impermeable embankments and lagoons contains between 20 and 30 per cent clay, the remaining fraction being well-drained sand and gravel. Soils of this type are likely to remain stable even when subject to significant changes in moisture content. Soils with a clay content much below 20 per cent are likely to exceed the recommended permeability limit of $1 \times 10^{-9} \text{ ms}^{-1}$ whereas if the clay content is much higher than 30 per cent they are

likely to be difficult to form into a stable embankment and they will have a greater tendency to shrink and crack on drying. The clay content of a soil is determined from particle size distribution analysis completed in accordance with BS 1377-5:1990.

Where the permeability of the soil on site is found to be too high it may be possible, depending on the type of soil, to reduce it to a satisfactory level by consolidation or reworking, or by blending it with imported clay-rich soils or minerals such as bentonite.

8.7.2 Effect of soil consolidation

The impermeability (and shear strength) of a clay soil can be improved by consolidation. During consolidation, the voids between the particles in the soil mass are reduced in size, making it more difficult for water to percolate. The maximum density that can be achieved through consolidation is related to the moisture content of the soil and compactive effort applied. In practice the compactive effort relates to the type and weight of compaction machinery used, the thickness of the layers in which the soil is placed, and the number of passes of the compacting machinery.

For each soil and level of compactive effort there is an optimum moisture content for the achievement of maximum density and a slightly higher moisture content for the achievement of minimum permeability. At moisture contents below the optimum, a clay soil becomes increasingly stiff and an increasing amount of compactive effort is required to break down the soil structure. Conversely, at moisture contents above the optimum, a clay soil becomes more difficult to work owing to the build-up of pressure in the water-filled pores.

The optimum moisture content for a particular soil (assumed to be homogeneous) is established by laboratory testing and will determine:

- 1 The minimum permeability that can be achieved given the natural moisture content of the soil on site.
- 2 The extent to which the moisture content of the soil on site should be changed in order to achieve the required level of impermeability.

8.8 DESIGN AND CONSTRUCTION

8.8.1 Design

Earth embankments forming part of a lagoon or bund should be designed in accordance with the requirements specified in BS EN 1997-1:2004 by appropriately qualified and experienced personnel.

Eurocode 7 is concerned with the design of earthworks in general, rather than liquid retaining structures and therefore appropriate allowances for the hydraulic loads which will arise in the event that a lagoon or earth bund fills with liquid (perhaps very rapidly) as a result of an incident should be made. A full consideration of this issue in the context of flood embankments is covered in CIRIA, Ministry of Ecology, USACE (2013).

Details of a typical embankment construction are provided in Appendix A8.

8.8.2 Construction

Site preparation

For lagoons:

- sites should be carefully cleared of all debris, vegetation and top soil, the latter being set aside for reuse
- soft spots or pockets where the soil type or condition have the potential to create areas of higher

permeability should be excavated and filled with soil of the same parameters as elsewhere on the site

- sewers or pipes, which pass under the site or within 10 m of it, should be stopped and sealed, and diverted as required
- drains or watercourses that cross the site should be diverted. Culverting beneath the site should not be used as an alternative.

For earth bund embankments:

- the site of the embankment should be cleared and prepared as for lagoons
- unless cut-off trenches are to be constructed, the embankment site should be loosened to a depth of approximately 300 mm before the first layer of embankment fill is placed.

Placing and compaction of impermeable fill material

The required moisture content of the fill material should be specified based on the results of the ground investigation and laboratory analysis.

The compaction of the fill material can be based either on a performance based specification, ie *in situ* testing of the completed works to ensure the specification is met, or a method specifications such as the *Manual of Contract Documents for Highway Works* (MCHW) (DfT, 199b), which specifies layer thicknesses and number of passes for a particular type of plant and soil type.

So far as is possible, each layer of soil should be placed and compacted along the entire length of the embankment or section of lagoon base in one continuous process. This is to avoid creating discontinuities that could lead to differential settlement and areas of weakness and potential leakage.

The interface between a concrete structure and earthwork bund, for instance where it is proposed to incorporate a valve chamber within the earth bund wall, is a potential area of failure and should be avoided where possible.

Where containment is to be provided by *in situ* reinforced concrete or blockwork bund walls and earth floors the foundations to the bund wall should be keyed into the earth floor (see Appendix A8).

Embankment and lagoon base protection

Unless they are to be covered with a hard pavement or a separate membrane lining, embankment sides and tops should be covered evenly with 150 mm of topsoil and seeded with grass. Grass can aid protection of the embankment by the establishment of a good grass sward together with appropriate forms of reinforcement, if required. Grass should be maintained by mowing or grazing to establish a good sward and prevent the establishment of self-sown trees. Well maintained grass can assist in preventing weather erosion and can also provide protection against damage from firefighting water and wave action. Advice on appropriate seed mixes can be found in Hewlett *et al* (1997).

On no account should shrubs or trees be allowed to establish on embankments, where they would seriously impair stability, or on lagoon floors, where they could create a leakage path.

The banks and base of a lagoon should be adequately protected against scouring at the points where site drains discharge and where, in an emergency, firefighting water would be likely to enter.

Protection from burrowing animals should be provided. This can be in the form of netting or mesh placed under the topsoil layer.

8.9 EMBANKMENT AND LAGOON LININGS



One of the principal differences in the recommendations for class 1 and class 2 and class 3 lagoon and bund construction is that class 2 and class 3 should both incorporate impermeable membrane linings.

There are many types of lining system each with their own advantages and disadvantages when used in the potentially aggressive environment of a containment system.

Where the bund is to contain flammable substances any lining system should be fire resistant or provided with a layer of protective material to ensure its integrity is maintained during an incident. It is therefore important that protection from fire is included in risk assessment for selecting different types of lining systems. The BS 476 series of standards provide a good guide.

A summary of commonly used lining systems is presented at Part 4 of HSE (2009a) and is reproduced at Table 7.2 for reference.

It should be noted that the 'advantages' and 'disadvantages' may vary subject to site conditions. The list is indicative only and not exhaustive. Fire resistance is covered in the table to reflect the current knowledge of performance based on product information, performance in fire incidents and some testing that has been carried out by operators.

Table 8.2 Lining system options (HSE, 2009a)

Option	Advantages	Disadvantages	Fire resistance	Cost*
Synthetic				
Polyethylene (HDPE)	<ul style="list-style-type: none"> resistant to water, hydrocarbon and most chemicals. 	<ul style="list-style-type: none"> requires protective layer potential hidden problems around seals and penetrations base ground to be prepared well, ie remove stones, requires a layer of gravel and sand/geotextile before the liner requires specialist installer to weld joints. 	<ul style="list-style-type: none"> very low burns readily if unprotected 	Medium
Polypropylene (PP)	<ul style="list-style-type: none"> resistant to water and oils easier to lay than HDPE. 	<ul style="list-style-type: none"> limited resistant to fuels requires protective layer potential hidden problems around seals and penetrations base ground to be prepared well, ie remove stones, requires a layer of gravel and sand/geotextile before the liner requires specialists installer to weld joints. 	<ul style="list-style-type: none"> very low burns readily if unprotected 	Medium
Synthetic rubber and EPDM	<ul style="list-style-type: none"> resistant to water. 	<ul style="list-style-type: none"> not resistant to oils and fuels requires protective layer. 	<ul style="list-style-type: none"> very low burns readily if unprotected 	Medium
Polyvinylchloride (PVC)	<ul style="list-style-type: none"> resistant to oils and water. 	<ul style="list-style-type: none"> not resistant to fuels requires protective layer potential hidden problems around seals and penetrations base ground to be prepared well, ie remove stones, requires a layer of gravel and sand/geotextile before the liner requires specialist installer to weld joints. 	<ul style="list-style-type: none"> very low burns readily if unprotected 	Medium
Polyurethane (PU)	<ul style="list-style-type: none"> water resistant 	<ul style="list-style-type: none"> not resistant to oils and fuels requires protective layer 	<ul style="list-style-type: none"> very low burns readily if unprotected 	Medium
Structural				
Concrete	<ul style="list-style-type: none"> proven durability able to cast around penetrations well suited to small congested areas hydrocarbon resistance. 	<ul style="list-style-type: none"> requires joints for construction and movement requires regular maintenance of joint and penetration sealants and cracks can buckle under heat net excavation waste can be high potential for settlement and cracking. 	<ul style="list-style-type: none"> very good joints and penetrations are the weakness 	High

Table 8.2 Lining system options (HSE, 2009a)

Shotcrete (spray applied concrete)	<ul style="list-style-type: none"> ease and speed of installation as concrete is sprayed on plant can be operated from outside the bund if necessary proven durability able to cast around penetrations hydrocarbon resistance. 	<ul style="list-style-type: none"> specialist contractors required requires joints for construction and movement requires regular maintenance of joint and penetration sealants and cracks can buckle under heat. 	<ul style="list-style-type: none"> very good joints and penetrations are weakness 	Low
Sand bitumen	<ul style="list-style-type: none"> remains flexible after installation resistant to puncture cracks can be repaired easily using hot bitumen hydrocarbon resistance. 	<ul style="list-style-type: none"> specialist contractors required requires joints for construction and movement requires regular maintenance of joint and penetration sealants and cracks can buckle under heat. 	<ul style="list-style-type: none"> very good joints and penetrations are weakness 	Low
Fibreglass	<ul style="list-style-type: none"> easy application suited to small areas hydrocarbon resistance. 	<ul style="list-style-type: none"> inflexibility needs to be catered for in design to allow for thermal movements and avoid overstress and de-bonding. 	<ul style="list-style-type: none"> low may require additional fire protection measures 	Low
Mineral				
Bentonite (geosynthetic clay liner) (pre-hydrated or dry bentonite requiring <i>in situ</i> hydration)	<ul style="list-style-type: none"> hydrocarbon resistance lower maintenance self-sealing properties if punctured pre-hydrated can be laid at performance specification required. 	<ul style="list-style-type: none"> requires a protection layer potential hidden problems at penetrations potential for drying out on slopes <i>in situ</i> hydration to dry system to achieve performance specification required can be uncertain. 	<ul style="list-style-type: none"> good as geotextile mat protected by layer of soil/stone 	Medium
Clay	<ul style="list-style-type: none"> inert material that has retained plasticity once in place hydrocarbon resistance. 	<ul style="list-style-type: none"> labour intensive, weather dependent and time consuming activity in spreading and compacting the clay requiring significant vehicle movements may not be safe to carry out installation while tanks are in service due to machinery requirements. 	<ul style="list-style-type: none"> high (non-flammable thick malleable layer) normally covered with top soil layer which provides further resistance 	Medium

Note

* costs are indicative and may vary based on installation issues and scale.

Further, detailed guidance is provided in EI (2012c) that seeks to provide a method for:

- appraising liner design criteria
- appraisal of options
- installation
- operation
- decommissioning.

There are a number of parallels with the waste management industry where landfills are lined with geomembranes to contain leachates that are potentially harmful to the environment. The Environment Agency has produced a number of guidance documents on the specification, installation and testing of geomembranes that can be found on their website (see *Websites* box). EA (2009b) stresses the need for quality control in the manufacture and installation of geomembranes. It also makes it a requirement of the environmental permit for the landfill containment system that a construction quality assurance (CQA) plan is prepared for the works.



Where a liner is to be installed for a class 2 or class 3 lagoon, the works should be completed in accordance with a CQA plan.

8.10 ANCHORAGE AND PROTECTION

Membranes need to be securely anchored and protect from mechanical and UV damage. A typical method is illustrated by Figure 8.5.

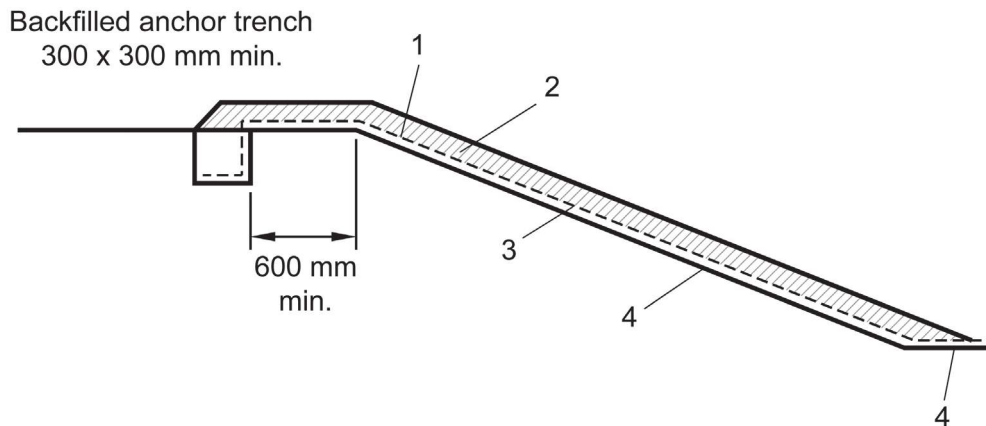

Notes

- 1 Impermeable lining membrane.
- 2 150 mm to 300 mm layer of stone-free soil to provide UV protection. Maximum bank slope 1 in 3 for soil stability. Steeper slope possible by placing the soil layer on a synthetic fibre underlay on top of the membrane.
- 3 50 mm sand blinding or geotextile mat to protect membrane.
- 4 Embankment and base soil treated to prevent weed growth.

Figure 8.5 Typical arrangements for protecting and anchoring a membrane liner

A similar detail is provided where an earth-floored containment with *in situ* reinforced concrete bund walls has to be lined (see Figure 8.6).

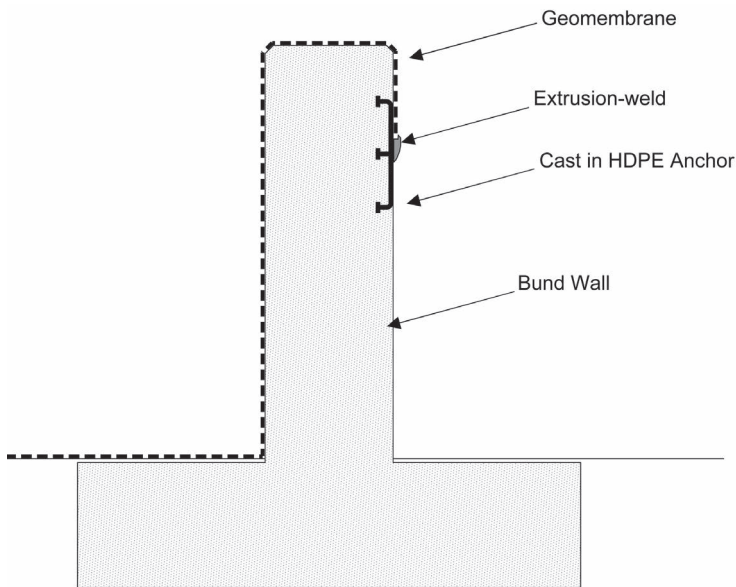

Figure 8.6 Typical arrangements for anchoring liner to concrete bund wall

Embankments should be sufficiently large and structurally stable to allow for movement of mechanical plant, which may be used for maintenance of the banks. Concrete or hardcore ramps may be required for access into bunded areas and concrete headwalls may be needed for pipe or channel inlets and outfalls. The construction of these elements should be carried out carefully to protect the integrity of impermeable liners, particularly at the joints between concrete and liner. Granular overburden is often provided both to protect a liner and to allow access for machinery. Further detail can be found in CIRIA, Ministry of Ecology, USACE (2013).

8.11 PIPE ENTRIES THROUGH EMBANKMENTS

Unless it is not reasonably practical to do so, embankments should not be penetrated below the design liquid surface level. Where it is necessary for a pipe to penetrate an embankment, a sleeve should be installed through the embankment through which the pipe will pass and be sealed as shown in Figure 8.7.

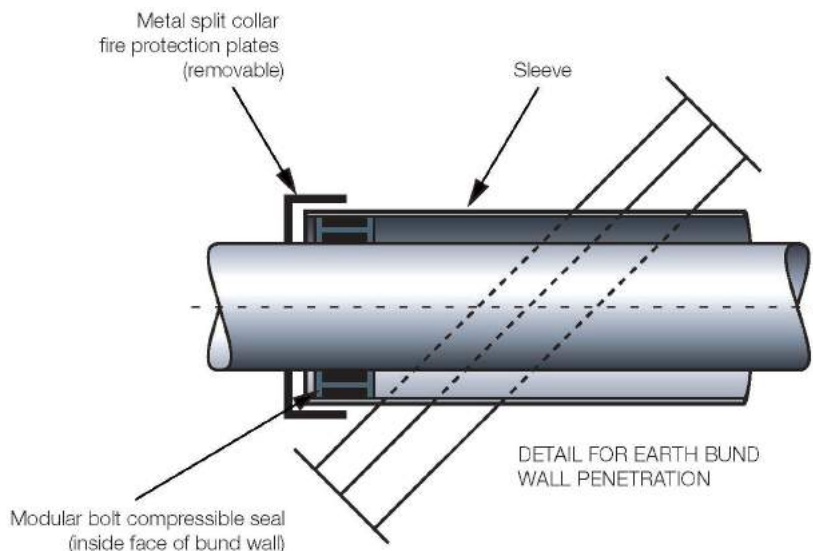

Figure 8.7 Detail for earth bund wall penetration (HSE, 2009a)

Anti-seepage collars should be provided along the sleeve at a spacing of not more than 10 times the pipe diameter and a flashing piece welded to the liner and secured around the sleeve by stainless steel band clamps or similar (see Figure 8.8).

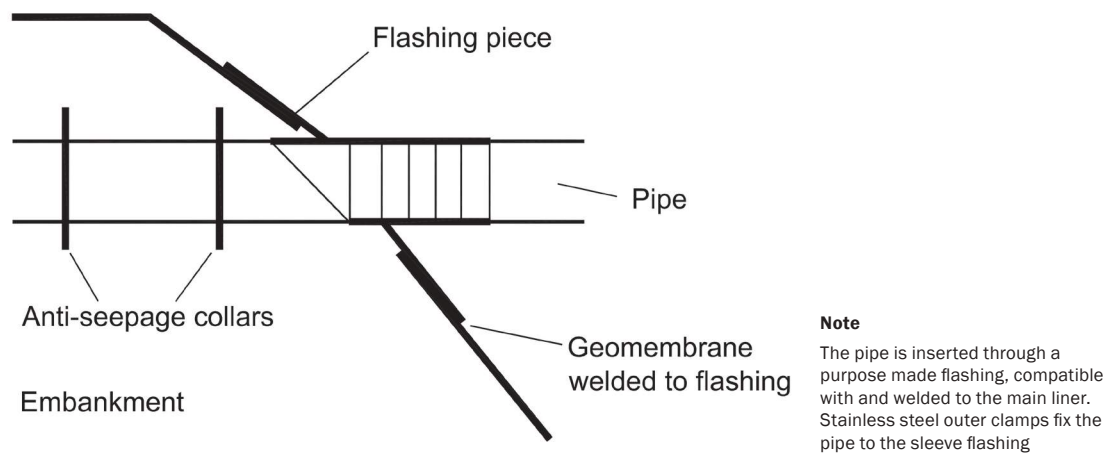

Figure 8.8 Arrangement for sealing pipe penetrating a geomembrane liner

8.12 LEAKAGE DETECTION FOR CLASS 3 LAGOONS AND BUNDS

Leakage detection is a requirement for class 3 containment lagoons so that they can be routinely tested for impermeability.

Several systems are used for leakage detection including the following:

- groundwater monitoring by boreholes **external** to the containment would be considered an example of good practice (this will only detect a leakage of contaminant from the containment system)
- resistivity measurement (EA, 2009b). This method is often used to check the integrity of the geomembranes during installation
- monitoring of underdrains or fin drains laid beneath the liner, although these might create a pollutant pathway if not properly capped.

Typical details of leak detection systems are provided in Appendix A3.

8.13 POST-CONSTRUCTION

While site investigation can provide an indication of the *in situ* permeability of soil or the characteristics of imported soil, where possible, cores should be taken of the completed works to confirm the permeability of the as-constructed structure.

8.14 MAINTENANCE

Regular inspection and maintenance helps prevent damage to liners from rodents and other burrowing animals. High tensile steel wire reinforced geosynthetics are available for protection against such attack. Alternatively, fine mesh wire netting may be used. These can also help resist erosion from weathering and/or wave action.

Maintenance of erosion damage caused by weathering and surface wave action may be minimised by the use of revetments or rip-rap placed on the embankment slope.

Depending on the nature and extent of any site damage, and the type of liner, it may be possible to make site repairs by patching. Instructions on repairs should be provided by the liner manufacturer or supplier. On sites with a high hazard or risk rating the entire damaged section should be replaced with undamaged material. Where a liner has deteriorated generally through age, it should be replaced entirely. Guidance on the inspection of liners can be found in EI (2012c).

Systematic regular inspections should be carried out. Vulnerable areas requiring special attention during maintenance inspections include:

- pipe entries, particularly if they penetrate the embankment
- the foot of embankments
- joints and discontinuities, particularly between dissimilar materials.

Websites

British Geological Survey: www.bgs.ac.uk

Coal Authority: <http://coal.decc.gov.uk>

Geomembranes (specification, installation and testing): <http://tinyurl.com/o3ryvyr>

Accessed 29 May 2014

9 Containment tanks

This chapter provides:

- A definition of a containment tanks and the factors to consider in their design and specification (Section 9.1)
- A review of options for tanks constructed above ground that could be used to provide containment (Section 9.2)
- A review of tanks constructed below ground that could be used to provide containment (Section 9.3)

9.1 INTRODUCTION

Chapters 6, 7 and 8 provide guidance on the design of containment bunds. However, tanks are an alternative means of providing remote containment. Tanks have an advantage over bunds due to their potential greater storage depths and smaller footprint per cubic metre of storage volume. In addition, it is more practical to cover tanks so managing accumulations of rainfall can be avoided.

Containment tanks should be designed, constructed, inspected and maintained to give the same level of integrity as the primary storage vessel. It may be possible to convert a primary containment vessel into a containment tank where there is insufficient space to provide alternative arrangements.

Depending on the site topography and layout, a pumped transfer system may be required. Figure 9.1 illustrates typical arrangements for above ground tanks using either a pumped or by gravity transfer system.

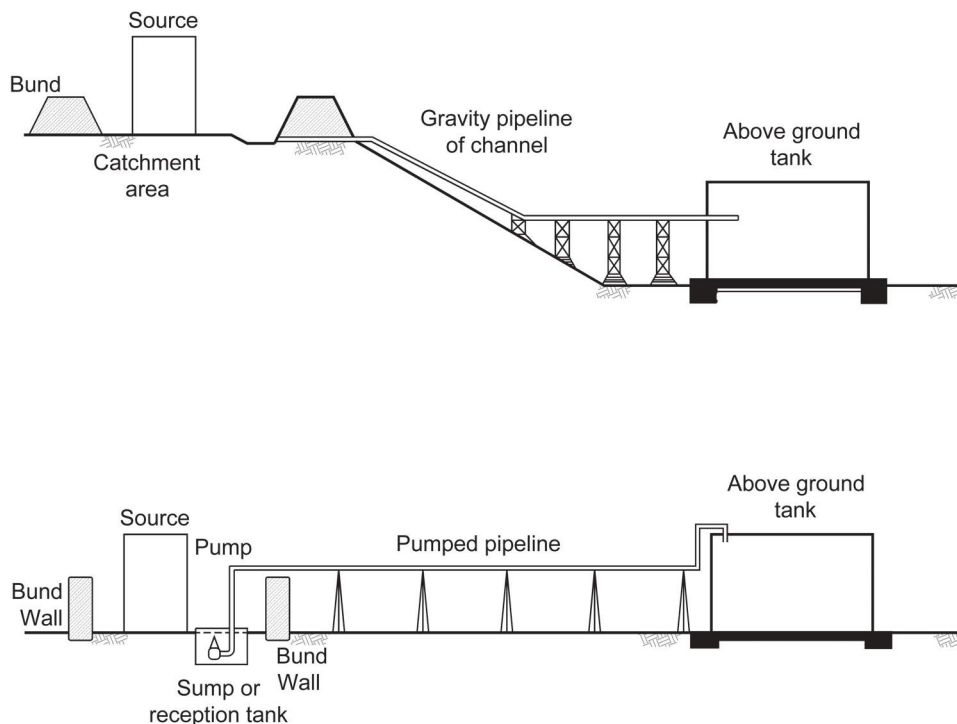

Figure 9.1 Typical arrangements for above ground tank systems

Factors that should be taken into account in selecting a containment tank include:

- site location
- topography
- ground conditions

- access provision
- overall site risk and classification (established in Chapter 2)
- health and safety requirements.

Each situation is likely to be different and so it is not possible to provide generic guidance. However, parameters including retention time, quantity and the nature of the material should be considered when selecting tank type, size, design standards and protective finishes.

9.1.1 Capacity

Where a tank is covered, rainfall can be excluded from the assessment of the containment capacity but rainfall at the source during the incident should be accounted for.

Advice on the required containment capacity is provided in Chapter 4.

9.1.2 Freeboard

A minimum 250 mm freeboard should be provided as buffer capacity for all containment tanks. No overflows are permitted within the freeboard depth.

The most onerous loading conditions should be considered for design purposes, ie the overall (tank-full) depth of the tank, including freeboard, should be taken as the maximum design depth when assessing the static head of contained liquids.

9.1.3 Leak detection

Depending on the class of the containment required, leak detection systems should be incorporated for ground-bearing tanks (see Section 6.3.2).



9.1.4 Inspection

Containment tanks should be subject to periodic examination and testing to ensure their integrity. Advice on a suitable examination and testing regime can be found in EEMUA (2003).

9.1.5 Firefighting water reservoirs

- Containment tank may have a dual use, for example to provide firefighting water during an incident but once depleted, to store contaminated runoff from the fire suppression activities. However, if they are mains-fed, care should be taken to prevent back-syphoning of any stored contaminated water into the mains water supply.
- Installation should comply with Water Supply (Water Fixings) Regulations 1999 or in Scotland with Scottish Water (2004).
- Firefighting water stored in tanks (or lagoons) may, in certain circumstances, be reused as firefighting water. However, such water may contain entrained flammable products that might further fuel the fire if recycled. If there is a risk that entrained flammable products might be present where a firewater lagoon is to be used as additional storage, there should be a mechanism to ensure that firewater does not become contaminated.

9.2 TANKS CONSTRUCTED ABOVE GROUND

9.2.1 Suitable tank systems

The majority of large capacity above ground containment tanks are assembled on site from prefabricated components, although *in situ* reinforced concrete construction is sometimes used where a characteristic

such as robustness is a particularly important factor. The principal categories of tanks suitable for above ground containment of hazardous substances include:

- proprietary cylindrical tanks as used for agricultural wastes
- welded steel tanks as used for oil, petroleum and other liquid products
- sectional steel rectangular liquid storage tanks
- reinforced plastics tanks
- reinforced concrete tanks
- reinforced concrete/masonry tanks.

Other materials sometimes used for above ground tanks include stainless steel, aluminium and plastics, although plastics can have poor fire resistance.

Protection from corrosion and aggressive conditions may be provided by a range of coatings including bitumastic paints, epoxy coatings, and rubber and glass linings. However, it is not possible to generalise on appropriate protective systems as these will depend on the particular circumstances of the site.

Another important aspect in selecting an appropriate tank is its ability to withstand inventory and firefighting water at potentially high temperatures as well as the thermal stresses this may induce in any lining system.

The various aspects of design, specification, fabrication and site works for above ground tanks considered suitable for containment, together with the relevant British Standards and codes of good practice, are summarised in Table 9.1 and in the following sections. Table 9.2 provides a simplified performance comparison for the tanks considered.

Table 9.1 Design standards for common forms of above ground tank construction

Tank construction	British Standard	Nominal capacity range
Cylindrical tanks as used in agriculture, founded at ground level on concrete base: <ul style="list-style-type: none"> ■ lapped and bolted vitreous enamelled steel sheets ■ precast concrete panel ('staves') held together by external hoops ■ corrugated galvanised steel panels ■ section precast concrete. (Section 9.2.2)	BS 5502-50 to BS 5502-22:2003+A1:2013 Class 1 standards (static head only)	Max circa 4000 m ³
Pressed steel sectional rectangular tanks, founded at ground level or on higher level support structure, static head. Recommended maximum depth 4.8 m (Section 9.2.3)	BS 1564:1975 Type 1	Modular tank system can be constructed to virtually any size
Site built, vertical cylindrical, flat bottomed, above ground, welded steel tanks (Section 9.2.4)	BS EN 14015:2004	Fabricated tanks that can be constructed to a wide range of sizes
Rectangular and cylindrical, horizontal and vertical carbon steel above ground oil storage tanks (Section 9.2.5)	BS 799-5:2010	Up to 150 m ³
Glass reinforced plastic tanks and vessels for above ground use (Section 9.2.6)	BS EN 13121-3:2008+A1:2010	The practical size of prefabricated tanks is limited by transportation issues to approximately 100 m ³ , however, modular GRP tanks are available with capacities up to 2000 m ³
<i>In situ</i> reinforced concrete liquid retaining and containing structures (Section 9.2.7)	BS EN 1992-3:2006	Not restricted

9.2.2 Buildings and structures for agriculture – storage tanks and reception pits

BS 5502-22:2003+A1:2013 provides a classification scheme for agricultural buildings/structures based on among other things the distance to a highway or habitable building and minimum design life. Class 1 is the most onerous of the four classes in terms of design requirements with a design life of 50 years.

BS 5502-50:1993+A2:2010 provides recommendations for the design and use of agricultural storage tanks and reception pits for liquid waste (slurry). Tanks constructed to this code used to provide secondary containment should be designed to BS EN 1504-5:2013 class 1 (as defined in that standard) and are restricted to class 1 secondary containment as defined in Chapter 2 of this guidance.

The four most common forms of construction for cylindrical tanks to BS 5502-50:1993+A2:2010.

- 1 Lapped and bolted vitreous enamelled steel sheets.
- 2 Corrugated galvanised steel panels.
- 3 Sectional precast concrete.
- 4 Precast concrete panels ('staves') held together by external steel hoops.

The walls are usually manufactured components of steel or concrete which are then site assembled on an *in situ* reinforced base which forms the tank floor. Walls are designed primarily to withstand circumferential hoop stresses, with no fixity at the base. Containment integrity is therefore dependent on the wall to floor joint and on the permeability of the *in situ* concrete floor. The tank base should be designed and constructed to EN 1992-3:2006.

Further design guidance on these types of tanks is contained in Mason (1992), which provides information on good practice for design, manufacture, installation, operation and maintenance. A revision is being prepared to reflect changes in the SSAFO Regulations expected in 2015.

9.2.3 Pressed steel sectional rectangular tanks

Pressed steel rectangular tanks are generally assembled on site from prefabricated sectional components. The elements are easily transported making the system particularly suited for confined sites and sites with poor access. It is possible to design tanks for future increases in volume and, depending on specifications, the tanks may be used to store a variety of liquids. Specifications should comply with BS 1564:1975 Type One tanks and their use limited to above ground installations.



Figure 9.2 A pressed steel sectional rectangular tank (courtesy of Braithwaite Engineers Limited)

Tank plates are designed with plate thicknesses depending on the density of the liquid and the height of the tank wall. The specification of the sectional plates should take account of the aggressive nature of the stored liquid and it may be necessary to provide a protective coating to the plates and joining material.

Bases may be configured with internally flanged plates allowing even contact with the foundation (sand/bitumen beds are recommended in such cases, but steel grillage can also be used). This allows leakage monitoring by observation of the base/foundation interface and a leakage test should be completed, using water, prior to commissioning the tank.

9.2.4 Site built, vertical cylindrical, flat bottomed, above ground, welded steel tanks

BS EN 14015:2004 covers all aspects relevant to the design of atmospheric storage tanks including:

- design pressure
- materials specification – steel and weld materials
- design loads
- design of tanks components (bottoms, shells, stiffening rings and wind girders, roofs, floating roof seals, attachments etc).



Figure 9.3 A vertically cylindrical welded-steel tank (courtesy M.C. Integ Ltd)

Corrosion protection methods include paints, epoxy coatings, glass liners and rubber liners, which can be specified in accordance with the nature of the stored product and required durability.

Tanks should be tested by filling with water before commissioning under controlled conditions. The performance of the tank and foundations can be monitored during the test.

Foundations of large diameter tanks should be designed to accommodate differential settlement as they are susceptible to damage as a result of foundation settlement.

Foundations can comprise a compacted granular fill sub-base or rigid concrete foundations over which bitumen/sand mix layer is provided to retard corrosion and provide a clean working surface for welding the bottom plates.

Pipes set around the perimeter extending into the granular fill sub-base/concrete foundation and protruding through the bitumen/ sand formation are commonly used to detect bottom plate leakage.

9.2.5 Oil storage tanks to BS 799-5:2010

Subject to durability criteria, tanks constructed to BS 799-5:2010 may be suitable for initial containment

prior to transfer to a larger facility, or at sites requiring only minimal containment capacity. The Standard includes design and fabrication specifications for all types of tank configuration.

9.2.6 Glass reinforced plastic (GRP) tanks and vessels for above ground

GRP tanks are made from glass fibre resin laminates manufactured under carefully controlled conditions using resins specified according to the intended use. The choice of resin affects chemical resistance properties and heat distortion temperature and is therefore an important consideration if reinforced plastic tanks are to be used to provide containment. The chemical resistance requirements are specified in BS EN 13121-2:2003 and the design, fabrication, inspection, testing and verification of GRP tanks in BS EN 13121-3:2008+A1:2010.

Due to the difficulty in achieving proper quality controls, site fabrication is not standard practice and therefore the capacity of a single tank is limited by transportation considerations. In practice, this limits individual tanks to a capacity of 100 m³ maximum although a number of tanks can be linked together.

Proprietary systems have been developed using tanks formed from composites of rectangular glass reinforced plastic (GRP) panels and steel frames and also vertical cylindrical GRP multi-straked tanks. These are similar in concept to the pressed steel rectangular tanks discussed in Section 9.2.3.

A number of thermoplastics lining systems can be specified to increase resistance to aggressive chemicals. Although GRP tanks may be manufactured to tolerate highly aggressive chemicals and effluents, when used above ground they are more susceptible to fire damage than steel or concrete tanks.

9.2.7 *In situ* reinforced concrete tanks

Above and below ground containment tanks can also be constructed using *in situ* reinforced concrete. The design of reinforced concrete structures to retain liquids is discussed in Chapter 7.

9.2.8 Precast concrete tanks

Precast or prestressed reinforced concrete wall panels can be used to form containment tanks. The wall panels can be cantilevered wall sections on suitable foundation or restrained with an external hoop (post-tensioned) and are sometimes referred to as multi-straked tanks. This is a common form of construction used to create slurry stores and filter beds at wastewater treatment works.



Figure 9.4 A precast concrete segmental tank construction (vertically multi-straked tank) (courtesy A-Consult Ltd)

An important consideration in specifying this type of tank is to ensure the joint between panels and between the panels and the base is both liquid tight and the sealant compatible with the inventory (and fire resistant where the inventory is flammable). Alternatively the tank could be lined, or the joints plated (see Figure 12.3).

9.2.9 Reinforced masonry tanks

Above and below ground containment tanks can also be constructed using reinforced masonry. The design of reinforced masonry structures to retain liquids is discussed in Chapter 7.

Table 9.2 Performance comparison for tanks constructed above ground

Tank construction	Suitability for			Volume	Ease of construction	Susceptibility to damage
	Class 1	Class 2	Class 3			
Buildings and structures for agriculture – storage tanks and reception pits (Section 9.2.2)	✓✓✓	×	×	✓✓	✓✓	✓✓
Pressed steel rectangular tanks (Section 9.2.3)	✓✓✓	✓✓✓	✓✓✓	✓✓✓	✓✓✓	✓✓✓
Site built, vertical cylindrical, flat bottomed, above ground, welded steel tanks (Section 9.2.4)	✓✓✓	✓✓✓	✓✓✓	✓✓✓	✓✓	✓✓✓
Oil storage tanks to BS 799-5:2010 (Section 9.2.5)	✓✓✓	✓✓✓	✓✓✓	✓	✓✓✓	✓✓✓
Glass reinforced plastic (GRP) tanks and vessels for above ground (Section 9.2.6)	✓✓✓	✓✓✓	✓✓✓	✓	✓✓✓	✓
<i>In situ</i> reinforced concrete tanks (Section 9.2.7)	✓✓✓	✓✓✓	✓✓✓	✓✓✓	✓	✓✓✓
Precast concrete tanks (Section 9.2.8).	✓✓✓	✓✓	✓✓	✓✓	✓	✓✓✓
Reinforced masonry tank (Section 9.2.9)	✓✓✓	×	×	✓✓✓	✓	✓✓✓

Key
 ✓✓✓ = Good
 ✓✓ = Moderate
 ✓ = Poor
 × = Not suitable

9.3 TANKS CONSTRUCTED BELOW GROUND LEVEL

9.3.1 Introduction

The design of below ground structures will need to take account of topography, the nature of the ground (geology), the water table and any other factor that may influence the integrity of the construction such as the aggressiveness of the soils. A detailed site investigation will often be an essential pre-require when considering the design of a below-ground structure.

The design of any below ground structure should be to BS EN 1997-1:2004 and BS EN 1997-2:2007:

- BS EN 1997-1:2004 covers the general basis for the geotechnical aspects of the design of buildings and civil engineering works, assessment of geotechnical data, use of ground improvement, ground reinforcement, dewatering and fill. Geotechnical design of spread foundations, piles, retaining structures, embankments and slopes. Calculation rules for actions originating from the ground, eg earth and groundwater pressures.
- BS EN 1997-2:2007 covers requirements for the execution, interpretation and use of results of laboratory tests to assist in the geotechnical design of structures.

For the design of a below-ground tank, it is of particular importance that a ground investigation establishes the following:

- 1 Groundwater level and any significant seasonal fluctuation to ensure the tank will not float (tanks, especially those in class 2 and class 3 should not generally be constructed in or immediately above the groundwater table).

- 2 A high groundwater level will impose a hydrostatic force on the tank when empty that should be considered in its design.
- 3 Bearing capacity of the formation.
- 4 Presence of contaminated soils.
- 5 Properties of the soils to establish design loadings.

BS EN 1997-1:2004 requires that the site investigation and geotechnical and structural design of a below-ground structure should be completed by appropriately qualified and experienced personnel.

9.3.2 Tank systems for use below ground

Many above ground tank systems may be designed and adapted for below-ground installation (manufacturers' specification should be checked to ensure suitability for below-ground use). Small capacity, welded steel and GRP cylindrical tanks are commonly used for below-ground storage of chemicals, fuel, oil and sewage effluent. Common types of structure for large capacity below-ground tanks are *in situ* reinforced concrete, sheet piled walls and deep shaft construction.

9.3.3 *In situ* reinforced concrete below-ground tanks

In situ concrete may be used to provide structural support for tanks made from other materials such as small capacity welded steel or GRP tanks installed below ground. In these circumstances it is not necessary for the concrete to be specified to BS EN 1992-3:2006.

This can serve a dual purpose by acting as additional containment, which will have particular relevance at a class 2 site. At particularly sensitive locations, a further containment system may be required in the form of, for example, a double geomembrane/geotextile incorporating a leakage detection facility that surrounds the enveloping concrete, giving an overall class 3 rating.

9.3.4 Deep shaft tanks

The 'bored shafts' technique describes the method of excavating and forming a vertical cylindrical shaft or tank, the circumference of which is usually concrete lined. After excavation the base of the tank is concreted to provide a watertight seal. Bored shafts are commonly up to five metres in diameter, although it is possible to go to nine metres (Figure 9.5).

Potential uses for bored shaft technique include containment tanks for a variety of substances, water and fire water reservoirs, abstraction well heads, sewage treatment, balancing tanks etc. The small plan area of the tanks gives a number of potential advantages, including minimal site area requirement and siting of full containment close to the source. The small effective diameter makes fire control easier within the tank. The system cannot be used in all ground conditions and the emptying costs are likely to be relatively greater than for a shallow below-ground containment tank.

9.3.5 Tanks formed with embedded walls of steel sheet piling

Continuous steel sheet piling for retaining wall construction can be used to form open storage reservoirs in impermeable soils. Advice on acceptable criteria for impermeable soils is provided in Chapter 8.

Where such a facility is to provide class 2 or class 3 secondary (or tertiary) containment, it should be lined and again advice on lining systems is provided in Chapter 8.

Advice on the design of sheet piled retaining walls is provided in Gaba *et al* (2003).



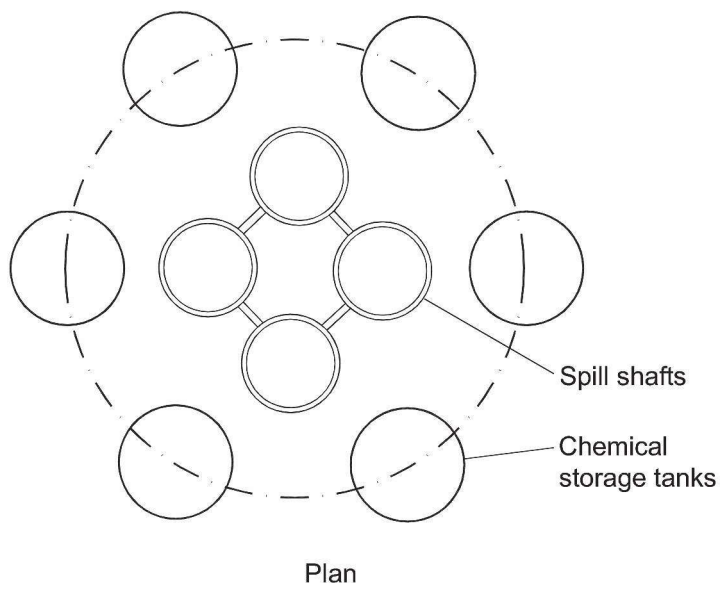
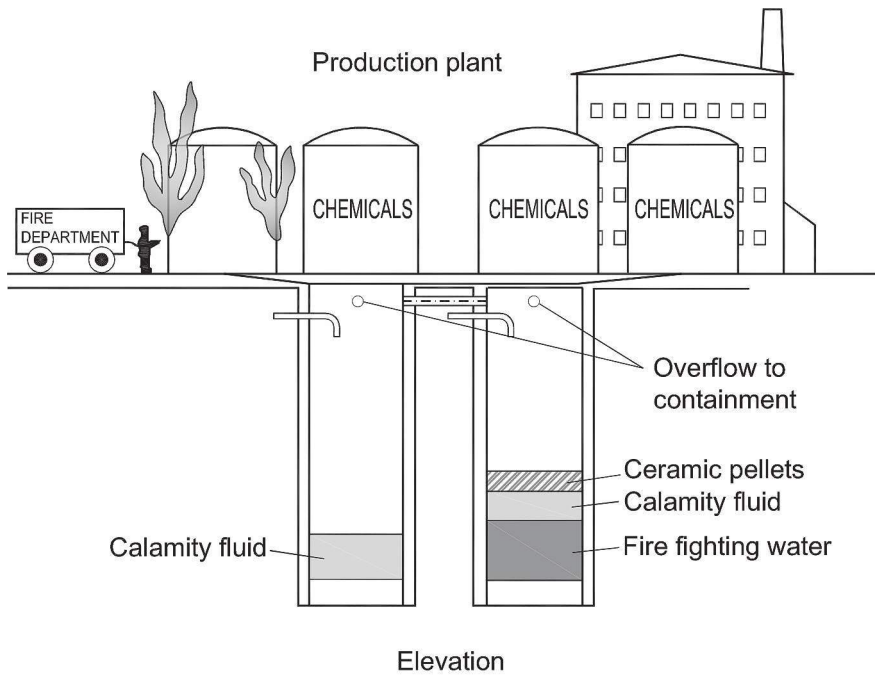

Figure 9.5 Use of multiple deep shaft tanks to provide containment adjacent to the source

10 Transfer systems

This chapter provides:

- A definition of transfer systems and the factors to consider in their design and specification (Section 10.1)
- Advice on the categorisation of catchment areas (Section 10.2)
- A review of gravity and pumped transfer systems (Section 10.3)
- A suggested classification system for transfer systems (Section 10.4)
- Advice on the design of the various elements of a transfer system (Sections 10.4 to 10.11)

10.1 INTRODUCTION

The term transfer system is used to describe the means for collecting and conveying spillage and contaminated water to the designated containment facility. This would include transfer to a remote secondary facility, or from a secondary to a tertiary facility.

Transfer systems comprise of **catchment areas** in the immediate vicinity of the primary storage vessel to control and channel any polluting materials ready for transfer, and **conveyance systems** to transfer the material from the catchment area to the containment:

- **Catchment areas** may be purpose designed and built with the sole function of intercepting polluting materials resulting from an incident. Alternatively, they may be areas such as roads, hardstandings and paved areas that double as catchment areas in addition to their primary purpose.
- **Conveyance systems** can comprise pipe networks, open channels or culverts. As with catchments, conveyance systems may be designed for the sole purpose of dealing with spillages and other incidents, or they may have a different primary purpose such as on-site roads.

Where 'dual-purpose' areas such as roads are to be used as part of the containment and/or transfer system, there should be a fail-safe mechanism to prevent inventory and firefighting water reaching the outfall of any associated the surface water drainage system.

The essential requirements of any transfer system are that it should be:

- leak proof
- sufficiently strong and durable to perform adequately for the duration of its design life with only routine maintenance
- resistant to fire
- resistant to attack from the materials that may be released from the primary containment
- of sufficient capacity to cope with the worst flow scenario without overflowing
- where the transfer system forms part of a road or access route, the design should not compromise emergency vehicular or pedestrian access and means of escape.

Material collected by the transfer system should be stored treated, where appropriate, and disposed of in a safe manner. Transfer systems should be designed to ensure that, as far as possible, incompatible materials do not come into contact with each other and cause secondary reactions or escalation of the incident. This may require larger sites to be segregated into catchment area zones (eg 'clean' and 'dirty', or 'acid' and alkali') so that the runoff from each may be dealt with separately. If clean water can remain segregated during an incident, the volume of contaminated water that would have to be treated can be minimised.

It should be noted that where an incident results from a catastrophic failure of the primary storage vessel, the principal concern may well be the capacity of the catchment area as it may be impractical to construct a transfer system with sufficient capacity to cater for this almost instantaneous 'surge' flow.

It should be noted that for local secondary containment systems comprising bunds, the transfer system is considered to be the bund floor (see Chapter 7 for concrete bund floors and Chapter 8 for earth or lined bund floors). This chapter is concerned primarily with transfer systems associated with remote and combined containment systems.

For disposal of contaminated materials following an incident, waste legislation is likely to apply. Accredited specialist contractors will have the necessary measures in place to deal with this.

10.2 CATEGORISING CATCHMENT AREAS

10.2.1 Categories of waste

Drainage on the majority of sites can be divided into three categories, commonly referred to as:

- stormwater drainage
- foul drainage
- trade effluent (the semi-solid or liquid by-product of commercial or business activities).

Stormwater drainage

This is designated essentially for clean water, ie surface water runoff generated by rainfall. Stormwater drainage that discharges to a watercourse or soakaway is normally subject to a discharge consent. Stormwater drainage discharging to the public sewer requires the consent of the undertaker, normally the local water utility. It should be noted that the discharge of trade effluent to the stormwater system is not permitted. With such outfalls it is essential that inlets to all stormwater drains are protected against ingress by sewerage and the effluent arising from an unplanned incidents (event effluent) comprising escaped inventory and/or rainwater and/or firefighting and cooling water.



On sites that are designated a moderate or high hazard risk rating, ie class 2 or class 3, all stormwater drainage should be designed to outfall initially to a holding facility (eg lagoon, reception tank or interceptor depending on the capacity required) so that any unplanned entry of polluting material into the system may be dealt with safely. Accumulated surface water runoff will only then be released following testing.

An alternative is to continuously monitor the surface water runoff and provide diversion arrangements to an appropriate containment system if:

- the monitors shows signs of contamination
- the instruments fail
- there is an emergency, in which case it should be possible to divert the flow manually or ideally remotely from the location where the emergency occurs.

Foul water drainage

This deals with sewage from site welfare facilities, canteens etc. and normally discharges to a water utility's wastewater treatment works (WwTW) via the public sewer network. It is important that trade effluent and/or event effluent is prevented from entering foul water drainage systems (unless it has been consented – see *Trade effluent*) as it may cause long-lasting damage to the treatment works process, which could in turn result in the discharge of untreated sewage.

In particular flammable material should be prevented from entering the foul water drainage due to the safety risks.

Trade effluent

Trade effluent is the semi-solid or liquid by-product of commercial or business activities. It may be consented to go to a water utility's WwTW (normally via the public foul sewer) or may have to go to a

dedicated industrial effluent treatment works. Where large volumes of effluent have to be dealt with, holding tanks may be required to buffer the impact on a treatment works.

This guide is not concerned with the management of trade effluent, but rather event effluent. As a general rule, operators should plan to retain the event effluent on site to allow it to be analysed before being sent to an off-site WwTW.

10.2.2 Site zoning

In planning a new transfer system, or assessing the adequacy of existing drainage systems for dealing with unplanned incidents, the site should be divided into catchment areas, each designated as either (clean) stormwater or event effluent or a combination of both. Catchment areas may be hardstandings, roadways, floors of buildings, roofs of buildings or any other areas that may be subject to runoff of rainwater or other material.

An assessment should be made of the amount of runoff likely to occur from any catchments designated as event effluent, or a combination of event effluent and stormwater. The approach described in Chapter 6 should be used to estimate the total event effluent likely to be released from a catchment area. The rate of release, which is the factor that affects the design of the transfer system, should be assessed by means of a detailed consideration of all of the events that could cause a release to each catchment area.

For a catchment area to be designated as solely stormwater there should be no possibility of the catchment becoming contaminated with event effluent during the course of an incident. In general, the higher the site's hazard rating, the more onerous will be the safeguards required to support the designation of a catchment as stormwater only.

Where a zone is designated as event effluent, it is important to identify the types of inventory likely to be released from it as the characteristics of the inventory, as well as its rate of release, will affect drainage design. Where more than one material is involved, consideration should be given to the characteristics of the 'cocktails' that could result. Important characteristics in terms of drainage design are:

- 1 Corrosive effects on materials used for constructing the drainage system.
- 2 Density (in particular whether lighter than water).
- 3 Flammability (liquid and/or vapour).
- 4 Flow characteristics (viscosity and changes in viscosity according to temperature and mixing with other substances or firefighting water).
- 5 Tumescence and possible solidification on burning.
- 6 Ability to segregate contaminated firewater from cleaner cooling water (increasing the chance of being able to recycle cooling water, reducing water use).
- 7 Ability to have staged handling of flammables, ie allowing gravity separation such that less contaminated liquid is transferred to the next stage/zone and reducing risk of incident spreading/escalating. However, there is a need to be mindful that foams inhibit gravity separation so any liquid leaving a separator is likely be contaminated (see Section 10.5.6).

This approach recognises that in some situations it may not be possible to design catchments or conveyance systems for all contingencies (for example, the very rapid release of materials stored in primary containment) but requires that any shortfall in, for example, conveyance capacity, is made explicit and that the consequences are understood and agreed with the regulator.

The output from the catchment assessment is used to design the conveyance system.

10.3 GRAVITY AND PUMPED TRANSFER SYSTEMS

Transfer systems can be designed to operate entirely by gravity, be pumped or a combination of both. The design of the system will depend on the layout of the plant and the topography of the site,

particularly the location of the primary storage areas in relation to the secondary containment. There are advantages and disadvantages associated with both types of system as outlined below:

10.3.1 Gravity systems

Advantages

- Simple and relatively inexpensive.
- Little to go wrong.
- Do not rely on operator intervention or automatic controls to activate.

Disadvantages

- Difficult to control flow rate.
- Pipework usually necessarily underground, making monitoring, inspection and maintenance more difficult.
- Requires human intervention to be available, diagnose and willing to operate.
- Constrained by site layout and topography.

It should be stressed that these notes refer only to transfer systems that are part of a remote or combined containment system. For systems where only local secondary containment is provided, gravity discharge arrangements should not be used.

10.3.2 Pumped systems

Advantages

- More flexibility.
- Pipework can be routed above ground.
- More control over transfer rates.

Disadvantages

- More complicated, so more can go wrong.
- Require reliable power supply and controls.
- Requires back-up system against mechanical and electrical failure.
- Even where there is a reliable power supply with a back-up system, the Fire and Rescue Service have been known to shut the power off for safety reasons.
- More maintenance required.

Many transfer systems are part gravity and part pumped. Ideally a transfer system would be gravity operated but with pipework supported above ground to enable effective monitoring and maintenance. In practice, the benefits of the inherent reliability of gravity systems have usually to be balanced against the convenience and accessibility of pumped systems.

10.4 TRANSFER SYSTEM CLASSIFICATION

Overall containment system classification is dealt with in Chapter 2. Table 10.1 summarises the performance requirements that components of a transfer system should meet to satisfy the overall system classification.

Table 10.1 Performance requirements for transfer system components

Main system component	Class 1	Class 2	Class 3
Catchments Table 10.2	Impermeable and resistant to the inventory and fire Designed to cater for flows arising from a credible scenario		Additional conveyance capacity such as bypass channels and identification of emergency flow paths
Pipes/channels Tables 10.3 and 10.4	Designed to cater for flows arising from a credible scenario		
	Pipes and channels and associated gullies, chambers and manholes to be liquid tight and resistant to inventory	As class 1 plus additional redundancies such as sleeved above ground pipework and alternative flow routes identified in the event of blockage	
		Pipework to be flexibly jointed (or sufficiently flexible) to cater for subsidence	
	Surface water drainage system should not be used a part of the transfer system		
Pumps [†]	Where the transfer system is reliant on pumping, provision for a back-up pump should be made	Dual (duty and stand-by) pumps and controls plus facility to mobilise temporary or additional pump capacity	
Telemetry and monitoring			Telemetry, including flow metering of all pipe runs to detect leakage Regular CCTV inspections of below-ground installations Alarm systems Other technologies may include permanent CCTV surveillance of above ground pipe networks
Construction supervision	Construction works to be independently verified (Section 7.2.1)		
Maintenance	Transfer systems to be regularly inspected (Section 5.2)		

Note

* Where the systems is totally reliant on a working pump, the pump and its controls should be designed to minimise any risk of failure, be accessible for repair and have a back-up in place. This is particularly relevant where fire damage is a possibility. The pump and its controls may be sited away from the bund or sump so that it can be maintained at all times during an incident. Dual (or stand-by) pumps should be considered. Alternatively, or additionally, portable pumps (which should be selected to be suitably ignition protected where they may need to operate in a flammable atmosphere) of an appropriate area classification for the intended duty with a rating equivalent to the fixed pump should be available in the event of an exceptional emergency or failure of the main system.

10.5 CATCHMENT AREA DESIGN

In the absence of a bund, most primary containment areas require an impermeable catchment to intercept spills and other unintended discharges. The area beneath and surrounding the primary storage vessel should be impermeable and contoured, or kerbed, to collect the spillage prior to its transfer by gravity or pumping to the remote secondary containment. Catchments may be constructed using earth (if sufficiently impermeable), or tarmac areas, but more usually they are constructed in concrete.

The effectiveness of a catchment area relies heavily on the ability of the downstream drainage system to transfer the spillage away from the catchment area at a sufficient rate to prevent overflow to surrounding areas that may not be impermeable. The catchment therefore may also have to attenuate the flow of event effluent by providing a degree of containment at the inlet to the transfer system, and effectively local secondary containment.

Catchment areas sometimes serve a dual purpose, eg to provide an impermeable hardstanding (such as a car park) or stable working area. The catchment function may be secondary to the main function, as in the case of roads, which may double as catchment areas. With roads, additional contouring and kerbing is likely to be required to ensure that spillages do not overflow.

For these reasons, where kerbing is to be used to collect spillage, or to direct it to a remote secondary (or tertiary) containment area, a high containment kerb system should be used. These are normally 400 mm high rather than the normal pavement kerbs adjacent to highways. Low points along the crest of the kerb should be avoided as this would reduce the capacity of the transfer system.

Areas of hardstanding and roads are normally drained and in many cases surface water runoff pass through an oil separators prior to discharge to a public sewer, watercourse or soakaway. However, oil separators cannot be relied upon to retain hazardous substances that might enter the surface water drainage system during an incident. For instance light oils might not be retained and firefighting foam can emulsify oil and cause pollutants to carry through gravity separators. It is also the case that unless it has been specifically designed for the particular incident scenario, the potentially high rate of flow through an interceptor may render it ineffective.

For this reason, dual purpose catchment areas such as roads should not be used for high hazard or risk situations unless stormwater is routinely collected in holding tanks for sampling prior to treatment (if necessary) and discharge or otherwise appropriately managed.

An alternative may be to provide a pollution control valve on the outfall of the site's drainage system. These valves can be remotely closed in response to the triggering of an alarm, or the detection of pollutants in the surface water runoff. However, reliance on such a system to retain event effluent during an incident should be subject to a risk assessment and discussed with the regulator. Such an arrangement is described in Case study 10.1.

Case study 10.1

Example of the use of a pollution control valve, Shropshire, UK (courtesy Hydro Consultancy)

Ricoh operate a site in Telford, Shropshire that manufactures toners for their copying equipment. The existing site surface water drainage system was identified as a direct pathway for accidental spillages of potentially harmful constituent components to reach sensitive downstream receptors.



To address this potential risk, in a scheme promoted by the Shropshire Wildlife Trust, a remotely activated lock-down valve and an underground off-line containment tank were retrofitted to the drainage system to provide a rapid-response system to spillages. When activated, the system rapidly closes part of the surface water drainage system with the spillage and any runoff diverted to a containment tank to be subsequently removed by tanker.

Analysis confirmed that containment of 100 per cent of the spillage and of any rainfall runoff occurring during an accident would be prohibitively expensive due to the significant storage volumes involved, particularly when considering the more extreme rainfall events and the time taken to deploy tankers.

The volume of the containment tank was optimised using hydraulic modelling by considering a range of response times to provide 100 per cent containment for 99 per cent of rainfall events based on a two hour response time, reducing to 80% of rainfall events for a 24-hour response time.

Further hydraulic analysis using a two dimensional modelling programme considered the fate of overland flows during an event when the containment tank capacity had been exceeded. This indicated that these excess flows could be contained on site within dock loading area.

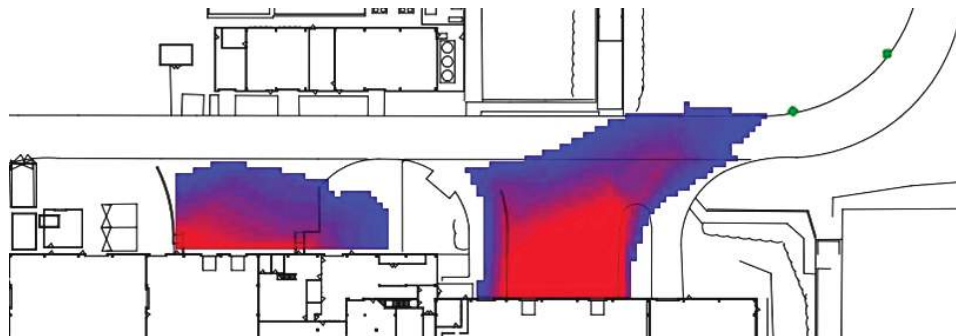

Forms of catchment construction are summarised in Table 10.2.

Table 10.2 Summary of common forms of catchment area construction

Form of construction	Design issues	Classification
Catchments with an earth base	See Chapter 8	Minimum depth of 1 m of impermeable soils is suitable for class 1 For a greater depth, or if a liner is provided, suitable for class 2 or class 3
Modular paving units and non-reinforced concrete	Modular units generally hand laid on a compacted granular sub-base. An underlying impermeable membrane, which should be able to accommodate deformation and be unaffected by deleterious materials, may be specified As the sub-base is likely to be relatively permeable, the joints of modular units should be sealed, or the units laid over a suitable impermeable liner	Classes 1, 2 or 3 if laid on a suitable impermeable liner and over soils
Reinforced concrete	See Chapter 7. Detailing for pavements should follow the DMRB (DfT, 1999a)	Class 1, 2 or 3
Flexible and rigid pavements	Flexible pavements tend to deform under concentrated loads and extreme temperatures although composite construction provides a superior performance for industrial use. Asphalt and DBM surfaces are susceptible to damage by many solvents and by fire	Class 1

One of the most common and reliable forms of construction for catchment areas is an impermeable *in situ* reinforced concrete base surrounded by a reinforced concrete upstand forming a shallow retaining kerb. Guidance on the design and construction of *in situ* reinforced concrete bund floors is provided in Chapter 7.

10.6 DESIGN FLOW

10.6.1 Failure of the primary storage vessel

The worst scenario is represented by the simultaneous occurrence of the following events:

- 1 The flow arising from the catastrophic failure of the primary storage vessel or any other credible scenario agreed with the regulator (allowing for any attenuation provided by the catchment area or local containment).
- 2 The maximum flow resulting from a one hour duration 10 per cent AEP rainfall event over the **whole** of the catchment drained by the transfer system (this is consistent with the rainfall event used to estimate containment capacity discussed at Chapter 4).
- 3 The maximum rate of application of firefighting water (see Section 4.3.4). Note that this requirement may be relaxed where non-flammable substances are involved.
- 4 Any potentially aggravating occurrences, eg drain blockage.

Point 4 should be considered as part of a HAZOP or similar assessment. When carrying out such an assessment it should be recognised that aggravating occurrences such as blocked drains may not be independent from points 1 and 3 since the released materials, or fire, may themselves encourage drain blockage.

While these scenarios represent the worst case and should be the start point for design consideration, a risk assessment, combined with location specific rainfall data (short- and medium-term) may demonstrate that the risk of a combined occurrence of fire (complete loss of containment with firewater) and worst case rainfall might be sufficiently low to be tolerable. However, this would depend on the scenario, eg if fire was caused by a storm then it could occur at same time as the worst case rainfall assumed.

Normal catchment and drainage design techniques can be used to calculate the design requirements for points 2 and 3.

Although it may often be impracticable to design a transfer system to cope with the highest possible flow rate that could occur on a site, it is important at least to recognise those scenarios where the design flows may be exceeded, particularly on sites with a high hazard or risk rating.

10.6.2 Tanker offloading and loading facilities

As risk assessment should be completed to consider the likely volume and flow rate of inventory that could be spilled during loading and unloading operations.

This should consider the:

- compartment volume(s) of the road or rail tanker
- maximum loading and/or unloading rate
- rate of application of firewater spray from any fire suppression systems installed
- rainfall rate over the catchment area of the unloading facility (the rainfall associated with 10 per cent AEP rainfall event should be allowed for).

Similar storage provision should be made for rail tanker unloading areas.

Ventilated below-ground impermeable sumps or tanks may be used to increase the capacity of the local catchment area if required. Collection tank alarms and automatic shut-off valves at loading and unloading points are desirable on installations with a high hazard or risk rating.

10.6.3 Attenuation

It is unlikely to be practical or economic to construct a transfer system with sufficient capacity to cater for the almost instantaneous 'surge' flow resulting from a catastrophic failure of the primary storage vessel. So, some local secondary containment is likely to be required.

Even if the transfer system has the capacity to cater for the design peak flow, local secondary containment may be required due to head losses at the entry to the system. This can be provided by:

- raised kerbing
- low bund walls
- site levels (dished impermeable surface)
- channel drains
- sumps.

An alternative is to provide a detention tank. In addition to attenuating peak flows, they may also be used for dosing or neutralising harmful substances, for example by pH adjustment, prior to transfer to the remote containment. However, in these circumstances the tank would require either a valved or pumped outlet to retain the event effluent and facilities for dosing and agitation to ensure adequate mixing.



Detention tanks should be designed and constructed to a standard appropriate to the class of containment they are serving (see Chapters 7, 8 and 9).

10.7 OPEN CHANNEL DESIGN

Open channels are used to drain large areas, or for dealing with large flows. On many sites the channels may be formed by contouring and kerbing suitable catchment areas such as roads. The kerb height and width and slope of the catchment determine the flow capacity.

Where there is a risk of blockage, inlets to culverted and piped sections of the transfer system from the open channel should be protected with screens or grills.

Where unlined drainage channels are excavated, flow velocities should be limited to 0.5 to 0.8 ms⁻¹ to prevent scour of fine materials. However, the scour resistance of earth channels can be enhanced by planting with grass. Advice on grass lined channels can be found in Hewlett *et al* (1997).

Manning's formula (Chow *et al* (1988)) is the most commonly used method for determining open channel flow. The flow capacity Q of a channel (in the context of this guide the channel takes the form of a kerbed road) is given by the expression:

$$Q = (A/n)m^{0.67}I^{0.5}$$

Q = discharge (m³)

A = wetted perimeter (m)

m = hydraulic mean depth

I = slope (mm/metre)

n = Mannings coefficient (ranges from 0.0156 for smooth concrete to 0.12 for an earth channel overgrown with weeds, with an average value of 0.030 for a channel lined with short grass).

Manning's formula takes no account of head losses at bends and changes in section, so it is recommended that the hydraulic design of transfer systems should be completed by competent personnel.

10.8 PIPEWORK FOR TRANSFER SYSTEMS

The hydraulic design of pipework for transfer system should be in accordance with BS EN 752:2008.

A number of software packages are available to assist in drainage design, many of which include designs for detention and catchment storage. Further information on the design of piped drainage systems is given in Appendix A9.

Gravity transfer systems should be designed such that the peak design flow (see Section 10.6) can be passed without surcharging and should take account of any flame traps, siphons, restricting valves and meters included in the system.

Allowance should also be made for any change in state of the inventory during an event (see Section 10.2.2). For example, water applied to some flammable substances considerably increases their viscosity.

Pipework materials can suffer attack from:

- discharge of effluent from industrial processes (eg electroplating works)
- discharge of effluent from chemical laboratories
- discharge of sewage, where due to long retention periods septicity occurs
- aggressive groundwaters (eg in contaminated ground)
- less aggressive groundwaters, where there is a convenient drainage path that allows groundwaters to be continually replenished
- deformation of plastic pipes and liners due to hot liquors and aggressive materials.

Table 10.3 summarises the materials and properties of commonly used effluent pipes and Table 10.4 indicates the resistance of a range of pipe and jointing materials to trade effluents.

Pipes and joints in materials referred to in Table 10.4 are generally suitable for use in sewers and drains conveying surface water, foul sewage and trade effluent that can legally be discharged to public sewers. The ground conditions in which the sewer is to be laid can be corrosive to certain pipe and/or jointing materials and this can affect the choice of materials. Where a drain or sewer is liable to carry untreated and corrosive trade effluents, further consideration should be given to possible protective measures. Liquids at elevated temperatures are likely to be significantly more aggressive than those at ambient UK temperatures.

Table 10.5 provides a performance comparison for pipe materials used in transfer systems.

Table 10.3 *Pipework materials, properties and application*

Component material	Description and design references	Characteristics properties	Suggested classification
Clayware	<p>Manufactured diameters up to 1.2 m. Various classes of pipe are defined in BS EN 295-1:2013 depending on crushing strength. Bedding classes are provided in BS EN 1610:1998 and design data including design loads, imposed traffic loads and construction of trench bedding is given in Bedding construction and flow capacity of vitrified pipes (Bland, 1995).</p>	<p>Suitable for non-pressure application and use below-ground. Good internal and external resistance to aggressive chemicals. Buried clayware pipes prone to damage, which is not readily detected below ground. Ground movement may affect joint integrity.</p>	<p>Buried clayware pipes to BS EN 295-1:2013. Disadvantages, including potential loss of joint integrity, brittleness etc, limit recommendation to class 1 only.</p>
Plastic	<p>Two main categories:</p> <ol style="list-style-type: none"> 1 Thermosetting resins. 2 Thermoplastics. <p>Reinforced thermosetting resin pipes included glass reinforced plastics (GRP) and unreinforced sand and resin (RPM). GRP pipes available in diameters up to 4 m and for high pressure use.</p> <p>Polyolefin's: polyethylene (PE), polypropylene (PP), polybutylene (PB). Vinyl's: polyvinylchloride (PVC) acrylonitrile butadiene styrene (ABS). Extruded (PE) pipes made in diameters up to 3 m in welded form. Made in different densities, eg MDPE, HDPE, suitable for pressures up to 12-bar. ABS limited to about 300 mm maximum diameter. PP pipes made in diameters up to about 1.2 m PB pipes available in diameters up to about 600 mm.</p> <p>Detail design and specification data available from pipe manufacturers.</p>	<p>Strength reduces, temperature increases (thermoplastics show significant loss). PP and PB better high performance temperature than PE. Normal maximum operating temperature of most plastics about 200 °C. Categories (1) and (2) have good chemical resistance, which may reduce under stress or strain. Polyolefins can be heat welded. UPVC to BS EN 1452-1:1999 widely used for utility pipelines. UPVC pipes suitable for low pressure installations, careful design is critical for high pressure pipelines. Vmyn's may be solvent welded.</p>	<p>Depending on the nature of the effluent and site conditions, plastic pipes suitable for many above- and below-ground applications, and for some pressurised pipelines. Consideration should be given to potential effects of fire. Depending on various factors, plastic pipes may be considered for class 1 and class 2. Class 3 use depends on redundancies and other precautionary measures, eg dual pipes, sleeves, pipe bunds, and monitoring controls.</p>
Metallic	<p>Non-ferrous metals not commonly used for effluent pipelines.</p> <p>Welded steel and stainless steel pipes used throughout industry for conveying fuels, oil, foodstuffs and many chemicals. With adequate protection may be used from some harmful effluents. Steel pipes are fabricated in all diameters and welded steel is commonly used to form double-skinned pipes and independent sleeves for all types of pipe. Ductile iron is most commonly used metal for effluent pipes. Pipes available up to 1.8 m diameter, with standard bends and fittings to ISO 2531:2009 up to 1 m diameter. Pipe lengths from 6 m to 8 m. Ductile iron pipes for effluents should be specified to BS EN 598:2007+A1:1:2009. Detail design data provided by manufactures.</p>	<p>Suitability of steel for welding, and high tensile stress, allows fabrication of continuous above- and below-ground pipelines capable for withstanding high pressures.</p> <p>Typical specification for ductile iron pipe for materials with pH in range 4 to 12 would consist of a pipe to BS EN 598:1995 with an external coating of 200g/m² zinc to ISO 8179-1:2004, overlaid with a 250 micron epoxy seal coat. An additional outer skin of polyethylene would help combat aggressive soil conditions. Tape wrapping provides further protection. Internally, pipes typically coated with epoxy and lined with high alumina cement. Exposed end surfaces coated with epoxy. Pipes may be protected internally with polyurethane lining for materials with pH4. High alumina cement liners offer good abrasion resistance at flow rates up to 7 m/sec. Various proprietary joining systems available; specified according to use. Ductile iron pipes may be used above or below ground and for gravity or pressurised pipelines.</p>	<p>Subject to design, specification and construction standards, ferrous pipes should be used for class 2. This applies to above-and-below-ground installation and to gravity and pressurised networks. Class 3 installations require redundancies such as system duplication, together with full monitoring and control of leakage. In class 3 situations, pipes should be above ground level and within sleeves or ducts. Alternatively they should be within concrete ducts to BS EN 1992-3:2006, where located below ground level. Sleeves and ducts to conform to class 3. These provisions allow for easier inspection and maintenance.</p>

Table 10.3 Pipework materials, properties and application (contd)

Cement	Concrete effluent pipes may be unreinforced, steel or fibre reinforced, or prestressed. Principal design performance standards are BS 5911-1:2002+A2:2010 and BS EN 642:1995. Unreinforced pipes, made up to 1.4 m diameter, suited only to gravity flows. Reinforced pipes are up to 3 m diameter and used in some low pressure systems. Pressurised pipes also made in large diameters and used in pressurised systems. Number of proprietary pipe systems manufactured from composites of concrete and reinforced plastic. CPSA (2011) provides guidance on installation of concrete pipes.	Concrete is robust but prone to attack from sulphates in groundwater, acid effluents, sugars and bacteria. Expensive measures needed for protection and these tend to offset initial cost advantages of concrete. Pipe abrasion and erosion governed by material flow and nature. Pipe linings usually applied after manufacture; epoxy or polymer resins commonly used. Linings cannot be prestressed.	Unreinforced concrete pipes should be used for class 1 only. Reinforced and prestressed pipes should be used for class 2. Specifications and site installation controls should be high to warrant class 2. This recommendation applies to pipe components. Additional safeguards will be essential for class 3.
Joint materials	Many joints systems are proprietary or have been developed over the years by various bodies such as WRc. A number of jointing methods are also described in the British Standard for pipes such as BS 5911-1:2002+A2:2010, BS EN 295-1:2013 and BS EN 598:2007+A1:2009.	Most flexible joints rely on a form of spigot and socket. Other methods include double collared joints, sleeved joints and flanged joinings. Welding is used for thermoplastics, steel and some non-ferrous metals. Flexible joints rely on an elastomeric sealing ring or gasket. Ethylene-propylene rubber and styrene butadiene rubber used in preference to natural rubber for normal sewage effluent, since natural rubber subject to biodegradation in sewage. Some aggressive materials may require use of other synthetic polymers.	Since many jointing systems are proprietary, necessary to confirm the classification and agree the specification details with the manufacturer.

Table 10.4 Chemical resistance of pipework materials (from BS EN 752:2008)

Relevant standards	Material or product	Notes
BS EN 206-1	Concrete	Specification, performance production and conformity
BS 8500		Complementary standard to BS EN 206
BS 8110		Specifies structural use of concrete
BS EN 197	Cement	
BS EN 12620	Aggregates for concrete	BS 8500-2 specifies requirements for recycle aggregates
BS EN 13242, PD 6682-6:2003, BS EN 13055-2		WIS 4-08-02(41) and the <i>Specification for highway works</i> (42) give guidance on selection of pipe bedding materials
BS EN 295, BS 65	Clay pipes, fittings and joints, perforated pipes, manholes, jacking pipes, gullies and extra chemically resistant pipes	
BS EN 1916, BS EN 1917, BS 5911	Precast concrete pipes, inspection chambers, manholes and gullies	
BS 437, BS EN 877, BS 416	Grey iron pipes and gullies	
BS EN 598	Ductile iron sewer pipes and fittings	
BS EN 1852	PP pipes	
BS EN 12666	PE pipes	
BS EN 14364	GRP (UP) pipes	
BS EN 14758	Mineral modified PP pipes	
BS EN 13476	Thermoplastics structures wall pipes	
BS 4660	Ancillary underground drainage thermoplastics products	
BS 7158	Manholes and inspection chambers (plastic	
BS EN 124	Manhole covers and frames and gully gratings for roads	
BS EN 1433	Linear drainage channels	
BS 7099		BS 7097 is the complementary standard to BS EN 124
BS EN 13101	Manhole steps	
BS EN 14396	Manhole ladders	

Table 10.5 Performance comparison for pipework materials

Pipe material		Suitability for			Chemical resistance	Pressure pipeline	Above ground
		Class 1	Class 2	Class 3			
Clayware		✓✓✓	x	x	✓ ¹	x	x
Plastic		✓✓✓	✓✓✓	✓	✓✓✓	✓✓	✓✓✓
Metallic		✓✓✓	✓✓✓	✓	✓ ²	✓✓	✓✓✓
Cements	Unreinforced	✓✓✓	x	x	✓ ²	x	x
	Reinforced and pre-stressed	✓✓✓	✓✓	✓	✓ ²	x	x

Key

- ✓✓✓ = Good
- ✓✓ = Moderate
- ✓ = Poor
- x = Not suitable

Notes

- 1 Joints susceptible to chemical attack.
- 2 Requires internal coating to achieve chemical resistance.

10.9 FLAME ARRESTORS

Where there is a risk of flammable liquids and/or gasses being conveyed by the transfer system, consideration should be given to installing traps in gullies, inspection chambers and tanks etc to prevent the spread of fire.

10.10 SYSTEM TESTING

BS EN 1610:1998 describes procedures for air and water testing of drains and ancillary works for gravity pipe networks. All below-ground pipelines should be tested before and after backfilling.

Testing of pressure pipes should be completed in accordance with BS EN 805:2000.

11 Sacrificial areas and temporary containment

This chapter provides:

- An introduction to sacrificial areas and temporary containment (Section 11.1)
- Examples of sacrificial areas (Section 11.2)
- Advice on the preparation of emergency plans where sacrificial area or temporary containment forms part of the planned response to an incident (Section 11.3)
- Advice on emergency and temporary containment measures (Section 11.4)

11.1 INTRODUCTION

This section illustrates examples of sacrificial and temporary methods of containment that may be used as part of a planned range of measures to manage an incident. These methods should be seen as means of mitigating the failure of secondary containment, rather than a replacement for it.

Sacrificial areas ‘sacrifice’ the soil or other media within which the event effluent is contained whereas temporary containment includes a range of measures where event effluent is contained by the planned installation of temporary measures such as portable barriers and booms.

Where sacrificial areas form part of an emergency plan, the sacrificial soil or media used to retain the pollutant should be contained within a barrier as the release of contaminants would be an offence (see Section 1.5.3).

11.2 EXAMPLES OF SACRIFICIAL AREAS

11.2.1 Car parks, sports fields and other landscaped areas

The method relies on interception of spills and conveying the event effluent to an area designated as a sacrificial site area. Sites that may be designated for this purpose include suitably ‘engineered’ car parks, landscaped areas, sports fields etc.

The sacrificial area contains the spill within a depth of permeable soil or porous media (the sacrificial media), which should have sufficient infiltration capacity to cater for the inflow rate of the event effluent. The event effluent must be prevented from dispersing into other strata or groundwater by an impermeable barrier of clay, or by some other impermeable lining system.

The sacrificial area should be designed to allow infiltration into the sacrificial media to prevent runoff. This requires that the area is provided with adequate under-drainage to cope with percolation of rainfall and that the drainage outfall is capable of being shut off quickly and effectively during an incident.

After the incident, the sacrificial media should be excavated and disposed to a licensed disposal site as soon as possible after the incident. Alternatively the sacrificial media can be treated on site provided the activity is permitted by the regulator.

Areas drained by sustainable drainage systems that rely on infiltration devices such as soakaways and infiltration trenches and sites with a high water table are not suitable as sacrificial areas.

Figure 11.1 illustrates an example of a landscaped area used as a sacrificial area. The source is surrounded by an impermeable catchment for directing spills and rainwater towards the sacrificial area.

The sacrificial media allows infiltration to the percolation drains. In this example, a concrete lined open channel is used to intercept the outlets of the drainage pipes. A sluice is used to close off the outlet of the channel during emergencies. An impermeable liner and leakage detection system is set below the sacrificial media of granular fill.

Effective design of the system will require a site investigation to confirm the requirement for the sacrificial area to be lined and testing of the media to determine if it is suitable and to establish an appropriate size and spacing for any drainage pipes that may be required.

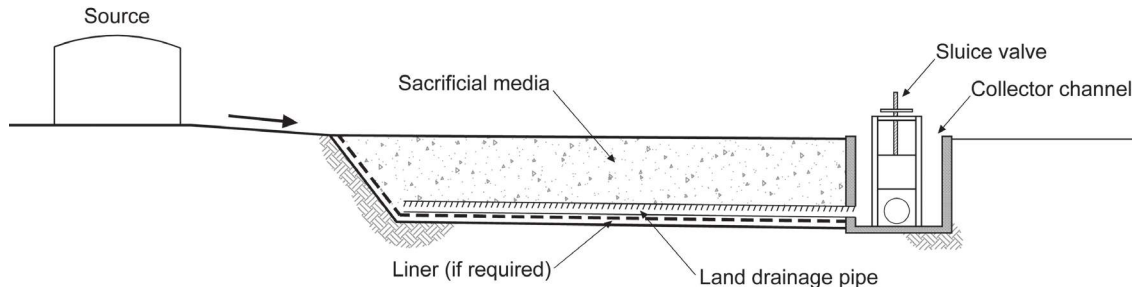

Figure 11.1 Section through a typical surface area using sacrificial media for containment

11.2.2 Areas surrounded by vertical cut-off walls

The most common method for constructing a vertical barrier wall is by excavating a trench under bentonite/cementitious slurry down to impermeable strata. The slurry hardens to form a low permeability, typically 1×10^{-8} to $1 \times 10^{-10} \text{ ms}^{-1}$, barrier with the strength of a stiff clay. Added integrity can be provided by installing HDPE or similar geomembranes vertically within the slurry. An example is shown by Figure 11.2.

Other methods involve excavation under a bentonite slurry followed by injection with a bentonite/cementitious grout.

The design of the cut-off wall should be informed by detailed site investigation to confirm presence and depth of an impermeable strata (aquiclude), any variation in the level of the aquiclude across the site and also the presence of any geological faults, fissures or discontinuities. The investigation should also determine the hydrogeology setting of the site and any physiochemical characteristics that may adversely affect the performance of the barrier wall.

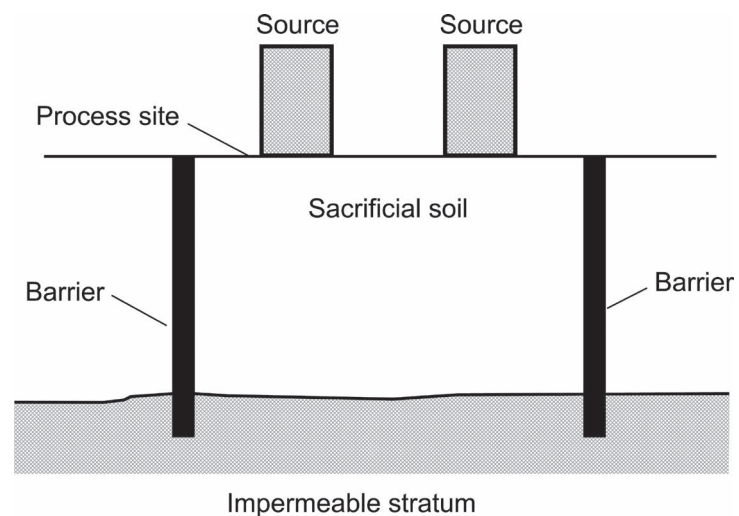

Figure 11.2 Section through barrier wall containment system

Vertical barrier walls may be used to enclose the entire circumference of a site rather than just a specific sacrificial area.

In the absence of an aquiclude, a low permeability horizontal layer can be created by grout injection, however, ensuring the integrity of such a system can be problematic.

As is the case for sacrificial areas, following an incident, the contaminated material within the cut-off wall will have to be either treated *in situ*, or removed to a licenced landfill.

11.3 EMERGENCY PLANS FOR SACRIFICIAL AREAS

The regulator should be consulted on the use of sacrificial areas for dealing with major spills. Sacrificial areas should not be located where they might endanger life or property in the event of an incident.

Where dual purpose areas are used for containment and these areas are provided with clean stormwater drainage facilities, it is essential that all operatives, the Fire and Rescue Service and any other emergency service, are made aware of the correct procedures for using the areas, including the diversion or closure of drains.

Where such areas are to be used for temporary containment, they should be clearly marked and fitted with audible alarms to warn operatives of the potential hazard when brought into use.

11.4 EMERGENCY AND TEMPORARY CONTAINMENT MEASURES

11.4.1 Introduction

Permanent containment facilities such as those described in Chapters 7, 8 and 9 will be provided at most sites as part of emergency planning for controlling hazardous substances. The plan should include incident response strategies and preventative measures for dealing with exceptional events that cannot be dealt with by the permanent facility, or the permanent facilities fail.

The provision of emergency and temporary containment measures should be determined on a case specific basis, depending on risk and the existence of other control measures, in accordance with the pollution prevention hierarchy. Guidance on this can be found within EA, NIEA, SEPA (2011b) and discussed with the regulator.

Where it is proposed to use booms, sand bags, cut-off trenches etc as part of the planned response to an incident, details of the planned response should be determined as far as is practical as part of the contingency planning, rather than trying to plan it during an incident, noting that it takes time for these containment measure to be deployed. Therefore, if they are to be relied upon, the scenario planning should demonstrate that there is adequate time, equipment and competent people available for their deployment at all times. A hierarchical task analysis is a means to demonstrate that this is achievable.

For example, where using booms across a river the following issues should be considered:

- the location of the boom in different event scenarios
- the amount of boom required in each situation
- ensuring that there are anchor points available to secure the boom
- the time needed to get the boom to the required location compared to the time it would take for the event effluent to reach the river
- the availability of resources to deploy the boom in an emergency situation, ie are they available 24/7/52
- ensuring that the personnel who are to install the boom have visited the site and are familiar with the location
- would access be compromised by the incident.

Similarly, if the contingency is for materials to be tankered off site for disposal to reduce volume of containment required on site, then the operator should consider:

- how many tankers are required
- can they reach the site before overtopping occurs
- would access be compromised by the incident

- will they be available 24/7/52
- can the drawdown rate match the rate required to prevent overtopping
- how long is haulage to disposal point/return journey
- how does this affect driving time and rest periods for drivers.

Advice on preparing an emergency plan can be found in PPG 21 (EA, NIEA, SEPA, 2009) and on managing a spill in PPG 22 (EA, NIEA, SEPA, 2011b). Further advice on responding to an incident can be found in Section 3.2 of DCLG (2008).

11.4.2 Temporary containment measures and emergency materials and equipment

Examples of temporary containment measures and emergency materials and equipment are below, and include:

- temporary bunding of car parking areas and other hard standings
- drain pipe seals
- interception/detention pits and trenches
- portable tanks and tankers
- absorbents
- booms.

Temporary bunding of car parking areas and other hard standings

Impermeable yards, roads and parking areas can be converted to temporary lagoons using sandbags, suitable excavated soils or sand from emergency spoil heaps to form perimeter bunds. This is shown schematically in Figure 11.3.

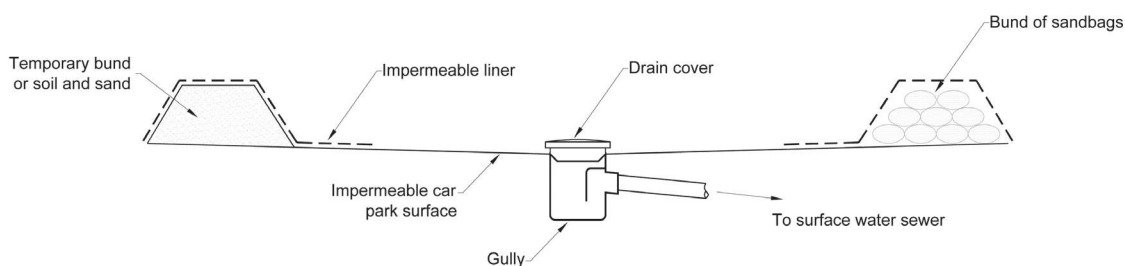

Figure 11.3 Sacrificial car park area showing temporary bunds and drain seals

Liners may be used to help protect the bunding material from contamination and to help improve the permeability of the land surface. Where soil or sand used for bunding becomes contaminated it should be properly disposed of as sacrificial material. Pits can be excavated and lined to form temporary sumps for collecting and pumping pollutants.

An alternative means of creating a temporary bund is the use of a 'barrier boom'. These are part inflatable and part water-filled booms designed to contain liquids on a hard surface and are similar in concept to a floating boom used to contain oil spills on water. A number of Fire and Rescue Services are now equipped with these booms. If reliance is to be placed on a boom as part of incident response planning, it will be important to establish with the Fire and Rescue Service if they would make sufficient available as part of their first response. Alternatively, operators should consider providing their own equipment where deemed necessary by the incident response plan.

All drain inlets such as gullies and manhole covers within the containment area should be sealed to prevent the escape of pollutants. Proprietary equipment for this purpose such as drain mats is available from a number of manufacturers.

Drain pipe seals

Pipe seals can be used within a drainage system to prevent the escape of spillages from the temporary containment area, which can have the added advantage of using the pipe-full storage capacity of the pipe network.

However, before relying on pipe network storage, the layout and condition of the system should be established (see Chapter 5) to prevent inadvertently creating additional pathways.

Seals should be kept in a readily accessible location close to vulnerable drainage runs. Care should be taken in their installation to avoid exposure to hazardous conditions within the drainage system and to ensure that the contained liquid does not overflow into other gullies or drainage systems. Special arrangements will be necessary to empty the system after use.

It is good practice that a record of where and when pipes have been sealed temporarily is maintained and also when they are removed.

It is also good practice that emergency equipment is stored securely, its condition checked periodically and that there are clear protocols for accessing this equipment in an emergency.

Interception/detention pits and trenches

Interception trenches should be used only where other methods have failed and where it is essential to protect life, or where the risk of damage to the environment, or property, outweighs the threat of ground or groundwater contamination. Where the natural ground is relatively impermeable, contamination will be minimised by removing the pollutant as soon as possible after the incident. Liners can be used as temporary barriers to improve impermeability although these cannot be used in fires or for deleterious substances. After the event, contaminated earth should be removed to a disposal site. Pits and trenches may help prevent the spread of burning substances.

Portable tanks and tankers

Portable tanks made from materials resistant to the spilt material can be used to contain small spills and might include IBCs, ISO tanks and stainless steel tanks. In most cases a sump or pit is needed to collect and pump the pollutant into the tank. Although care should be taken when pumping potentially flammable materials that the pump does not provide an ignition source.

Vacuum or similar mobile tankers may also be used for collecting and containing small spills. Where tanks and tankers are part of an emergency plan, these should be in a readily accessible location and maintained in a serviceable condition. However, vacuum tankers when handling anything flammable can exhaust flammable vapour, which if adjacent to unprotected electrical or non-electrical equipment, would constitute an ignition hazard.

Diesel truck engines (or diesel pumps) should be suitably protected to avoid ingesting such flammable vapours. Conventional 'gully suckers' should not be used for such work.

Where tanks and tankers are part of an emergency plan, these should be maintained in a serviceable condition and the time it would take to get them from their storage location factored into the emergency plan as should access under the scenarios considered.

Absorbents

Proprietary absorbents, as well as materials such as sand and sawdust may be used to soak up small spillages provided they will not react with the substance. Stocks of suitable absorbents should be available adjacent to potential spillage sites. The regulator is able to advise on suitable absorbents, including proprietary absorbents.

Contaminated absorbent should be disposed of appropriately under the producer's normal duty of care.

Booms

Floating booms are used to contain spills of oil and similar substances that float on water, to prevent migration and to facilitate clearing operations. As with barrier booms, a number of Fire and Rescue Services are now equipped with these floating booms. If reliance is to be placed on a floating boom as part of incident response planning, it will be important to establish with the Fire and Rescue Service if they would make sufficient available as part of their first response. Alternatively, operators should consider providing their own equipment where deemed necessary by the incident response plan.

Unless mechanically deployed, it is unlikely that a boom could be deployed directly around flammable materials due to the risk to personnel. In such circumstances a boom may have to be placed a safe distance from the spill and the spill allowed to spread to this safe limit. Note that it may simply be unsafe to deploy a boom at all.

12 Repair and upgrading of existing containment facilities

This chapter provides:

- An brief introduction to the upgrading of existing containment facilities explaining the links with other sections of this guidance (Section 12.1)
- Advice on the maintenance and repair of concrete bund walls (Section 12.2)
- Advice on the modification of earth bund (Section 12.3)
- Advice on the modification to existing bund walls (Section 12.4)
- Advice the repair and upgrading of drainage and transfer systems (Section 12.5)
- Advice the repair and upgrading of joints and pipe penetrations (Sections 12.6 and 12.7)
- Advice on upgrading warehouses (Section 12.8)

12.1 INTRODUCTION

This chapter provides advice on the repair and upgrading of existing containment facilities with reference to other chapters in Part 3 as appropriate. Upgrading of an existing containment facility may be required following an assessment described in Section 5.3.

12.2 GENERAL MAINTENANCE AND REPAIR OF CONCRETE BUND WALLS

This section describes the main problems that are likely to affect concrete bund walls and the repair techniques that are available. Concrete is an inherently durable construction material, suitable for a wide range of applications, but it still requires maintenance. Defects can develop when in service due to natural movements such as thermal expansion, or chemical attack or physical damage. Regular inspection by an experienced person familiar with the common deterioration mechanisms is necessary to ensure the asset continues to perform properly in service.

12.2.1 Defects

Defects may be categorised broadly as cracks, local surface deterioration, and general surface deterioration.

Cracks can be caused by stresses:

- at the time of construction (plastic cracking)
- that develop during service due to either thermal or shrinkage movement
- due to overloading such as vehicle impact
- as a result of expansion and heat damage to the concrete and reinforcement following a fire.

In addition, cracking of bund floors may be the result of uneven or inadequate ground support, or heave of the sub-soils.

Cracks that penetrate the full thickness of a wall or slab can compromise the containment if they are of sufficient width and can also lead to corrosion of the reinforcement. For water-retaining reinforced concrete structures, any crack greater than 0.2 mm was traditionally considered to have the potential to seep water, with finer cracks undergoing a process of self-healing when wet, provided the crack has stabilised.

For containment structures there are particular issues that need to be considered:

- low viscosity oils or solvents may penetrate through fine cracks of less than 0.2 mm, which may not self-heal

- acidic water (<pH 5.5) passing through a narrow crack will widen it and increase the rate of leakage
- waters containing halides such as chloride salts will attack reinforcement crossing the crack and result in loss of section (covered later in this section).

Concrete Society (2010) gives useful advice on the causes and interpretation of cracking in concrete structures.

Local surface deterioration may be caused by:

- variability in quality of the laid concrete (eg poor compaction in a particular area, often called honeycombing, which can penetrate deep into the wall or slab)
- local exposure to aggressive agents (eg small spills from a storage tank, sulphates in the ground)
- mechanical abrasion.

Variability in the quality of concrete is often easy to detect, as weaker concrete may remain damp for longer after rainfall and/or be a source of dampness or leakage through a wall or slab. Areas that are particularly prone to poor compaction are construction joints, with the kicker joint normally used to build the wall element off the slab or ground beam. Patches of dampness at the base of a wall just above the horizontal kicker joint may indicate honeycombing of the concrete.

Poorly compacted concrete or concrete that is poorly cured will be more prone to deterioration than well-compacted concrete. This includes increased risk of damage when exposed to freezing and thawing, reduced resistance to carbonation and chloride ion penetration and reduced resistance to acids or other chemicals.

Certain aggressive agents can attack the cement matrix itself (and where present, acid-soluble aggregate, eg limestone) leading to surface damage that, in its early stages, causes the aggregate to be exposed. Eventually the cement matrix may be weakened to the extent that the aggregate falls away, exposing a new surface, which is likely to be more porous and thereby accelerating the deterioration.

Concrete resists many aqueous liquids of pH 5.5 and above, but is primarily affected by sulfates and acids as well as some of the more unusual chemicals such as milk, which generates lactic acid (see Box 12.1). Further information on the resistance of concrete to a range of common chemicals is given in ACI (2013).

With low pH liquids, the reactions will be faster and damage can be severe and expansive, so additional protection is needed (see Section 12.2.3)

Sulphate attack of concrete is a chemical reaction that causes expansion and cracking in the concrete. Sulphates can originate from the soil or groundwater or from sulphates in chemical spillages and if the concrete is not designed to current standards for the level of exposure, severe sulphate expansion can weaken the element and affect the performance of the containment.

Table 12.1 Possible reasons for using surface protection on cementitious surfaces (after Concrete Society, 1997)

Description	Commentary	Action
A joint with a stainless steel waterstop and fire and product resistant sealants	This meets current good practice and no upgrade would be required. It is unlikely to have a significant rate of liquid egress from the joint during an incident, with or without fire.	None
A joint with a plastic waterstop and stainless steel cover plate designed to ensure product and fire resistance to BS 476	This meets current good practice and no upgrade would be required. It is unlikely to have a significant rate of liquid egress from joint although loss of integrity of the plastic waterstop may eventually occur after protracted heat exposure	None
A joint with no waterstop but with a stainless steel cover plate, with product and fire resistant sealants designed to ensure fire resistance to BS 476	This joint may be considered to be fire resistant and would be considered impermeable (liquid tight) whilst the product-resistant sealant remains in good condition. Leakage rate through movement of the joint would also be expected to increase with sealant ageing.	Frequent sealant inspection and replacement routines should be in place to ensure sealants remain in a good condition.
A joint with no waterstop, no cover plate but with product- and fire-resistant sealant	This joint only provides limited fire resistance and is impermeable only when the product resistant sealant remains in good condition. Leakage rate through movement of the joint would be expected to increase with sealant ageing.	As a minimum, this should be upgraded with a stainless steel cover plate and inspection and replacement routines shall be in place to ensure sealants remain in good condition
A joint with product-resistant sealant but no waterstop, no stainless steel cover plate and no fire-resistant sealants	This joint will be impermeable whilst the sealant remains in good condition but is not fire-resistant, and would be expected to leak rapidly following a fire. Leakage rates through movement of the joint would be expected to increase with sealant ageing.	As a minimum, this joint should be upgraded with a stainless steel cover plate and fire-resistant sealants. In addition, inspection and replacement routines shall be in place to ensure sealants remain in good condition.

Physical damage, such as mechanical abrasion, will not only appear unsightly, but the loss of thickness of concrete over the reinforcing bar can accelerate deterioration, leading to corrosion of the reinforcement. As necessary, an additional harder-wearing concrete layer or a surface protection system may need to be added.

General surface deterioration can be the result of:

- exposure to aggressive agents over a wider area
- inadequate specification and/or poor standard of construction
- inadequate curing
- exposure to freezing and thawing cycles
- mechanical abrasion.

Often, the cause of general surface deterioration can be attributed to issues with the original concrete design specification and/or the workmanship used, and is indicative of a general failure of the concrete to resist the prevailing environment. Codes and standards for the design of reinforced concrete have changed significantly over the past 20 years and current requirements have become onerous in terms of strength and composition.

Where unacceptable and widespread deterioration is taking place that could weaken the containment structure, general additional protection may be needed using a surface protection system, or replacement of the affected elements may be justified.

Corrosion of reinforcing bar in a wall or slab can be caused by a variety of different mechanisms. The most common causes are exposure to acidic gases (eg atmospheric carbon dioxide) or halides such as chloride ion from sea spray (eg coastal facilities, chloride-containing spillages).

Corrosion of bars is often first seen in the concrete surface in areas where the concrete quality is poor or the cover thickness is particularly low. Initiated by 'carbonation' of the concrete, or chloride salt penetration, the reinforcing bar begins to rust, resulting in expansion on the bar surface that cracks the concrete and eventually it spalls off. This is not only unsightly, but it will propagate, with the spalling and corrosion getting progressively worse. This will weaken the wall or slab and in severe cases could lead to structural weakening depending on the location (eg the base of walls by the kicker joints is a point of maximum stress under hydrostatic or surge loads).

Corrosion of reinforcement down cracks or at joints due to leakage can result in localised corrosion and loss of bar cross section, so affecting strength and dowel action. Leaking cracks that have either typical white staining from the dissolved salts leaching from of the concrete, or brown staining typical of rust, are warning signs of potential problems.

12.2.2 Repair techniques

Before an appropriate method of repair can be specified, the cause of the damage should be established and if possible, removed or otherwise mitigated. Guidance on the deterioration and repair of concrete structures is given in many publications and most recently in BS EN 1504-9:2008 (see also Grantham, 2011), Institution of Civil Engineers (2009) (which covers concrete mix design, properties, testing and repair) and Concrete Society (2009b).

BS EN 1504-9:2008 provides 11 principles and 43 methods of repair relating to degradation of the concrete matrix or corrosion of the reinforcement. In accordance with Regulation (EU) No 305/2011 (CPR), manufacturers apply to have their products tested and certified for compliance to one or more methods of repair, and have to achieve the minimum performance requirements for the relevant part of BS EN 1504-9:2008 dealing with the method or methods, for which the product receives a CE mark. In selecting an appropriate product, it is therefore important to establish the cause of the defect and choose materials certified to the correct method.

Figure 12.1 summarises the common deterioration processes that affect concrete and reinforced concrete structures, based on BS EN 1504-9:2008.

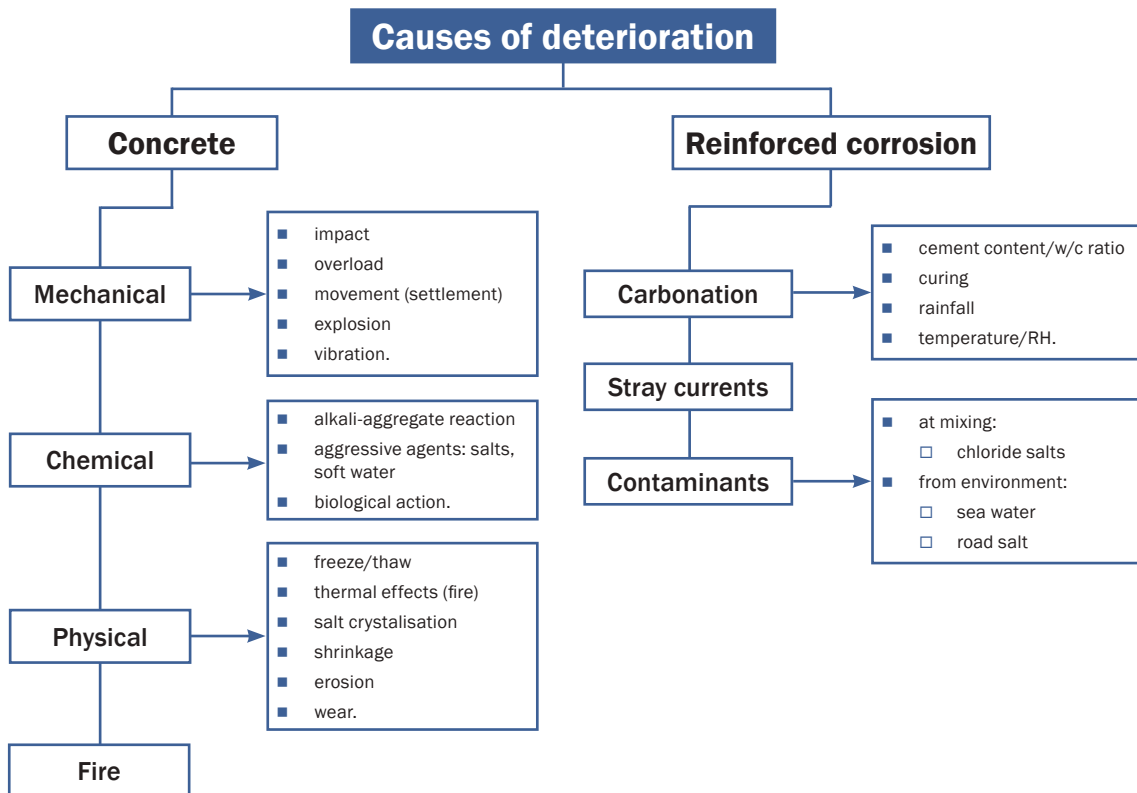

Figure 12.1 Common deterioration processes that affect concrete and reinforced concrete structures (after BS EN 1504-9:2008)

The common repairs that are needed for concrete containment structures, and where specific methods apply, include:

- crack repair
- chemical attack due to spillages
- filling holes/penetrations through walls
- addressing corrosion damage
- modifying walls (see Section 12.3)
- upgrading surface protection (see Section 12.2.3).

A general guide to repair techniques is provided in Appendix A10, which also contains a full listing of principles and methods for repair.

Cracks have a variety of causes and so proper investigation as to their cause is needed before they are treated. Moving cracks that respond to daily or seasonal temperature changes are 'live' and more difficult to address, compared with 'dead' or inactive cracks. Cracks through the full thickness of the wall or slab that leak, should be sealed to prevent leakage and protect the reinforcement using materials approved for BS EN 1504-9:2008 Method 1.5 (filling of cracks).

Where cracking is non-structural, due to thermal or shrinkage stresses, the crack width may be substantial (over 1 mm) if the design or construction was inappropriate. To be effective, the crack should be sealed by injecting a rigid material into the full thickness of the element, as this will protect the material from sunlight or the effects of heat if there were a fire. Surface treatments pointed into chases in the surface will be more prone to failure.

Where the crack is actively opening and closing in response to temperature, the materials used must be ductile as well as leak-resistant. Guidance on the performance of materials for sealing live and dead cracks is given in BS EN 1504-5:2013. If the movement is excessive and beyond the range of the injection materials, then the crack will need to be detailed as a proper joint that will accommodate movement yet remain leak-resistant (see Section 12.6).

Where wide cracks are forming and opening under applied loadings, eg at the foot of the walls of a bund during a hydrostatic or load test (see Chapter 5) to assist with assessing the structural integrity of the wall, this may indicate structural deficiency due to the design being inadequate for the intended loads. If so, it may be necessary to structurally strengthen the wall by injecting the cracks with a structural injection product and to:

- reduce future loadings (while the volume of primary inventory could be reduced, there is no guarantee that during an incident the bund could not be completely filled with firefighting and or cooling water. Therefore an overflow would have to be introduced to reduce the depth of liquid that could be retained)
- strengthen or prop the walls.

Alternatively, it may be necessary to reconstruct the wall.

If a bund floor is cracked, this may be the result of inadequate or uneven support and the subgrade will need to be treated and stabilised before the slab is repaired, otherwise the problem will recur. This may require breaking out the damaged slab, although there are techniques available to inject beneath slabs to strengthen and support them.

Chemical attack causing localised damage to a bund floor can be addressed by cutting out the affected material back to sound concrete and using a bonded thin-layer repair mortar or concrete to BS EN 1504-9:2008 Method 6.3 (adding mortar or concrete) that complies with BS EN 1504-3:2005 to restore the profile. Depending on the cause of the localised damage, the repair may need to use a resin rather than cementitious binder to combat particular chemicals. Alternatively, the bund may need application of a surface protection system to BS EN 1504-9:2008 Method 6.1 (see Section 12.2.3).

Filling holes/penetrations through walls or slabs is often required as a result of changes to pipe routings, identification of deficiencies (eg tie-bolt holes) or other causes. Repairs can be completed using materials complying with BS EN 1504-9:2008 Methods 3.1 and 3.2 that are suitable for the intended size of repair. In all cases, the hole should be cleaned and any lining material removed (eg plastic sleeve).

Tie-bolt holes in walls that are less than 50 mm diameter can best be plugged with a stiff, dry mortar forced into the full depth of the hole to form a complete seal.

Larger holes (eg core holes and pipe penetrations) require the sides to the inner face to be cut back and roughened to provide a tapering hole that will form a wedge against hydrostatic pressure, before they are filled with trowel-applied repair mortar or a flowing concrete (which for walls will need formwork fixed in place).

Large openings, typically where the smallest dimension (width or height) is greater than 0.5 m, particularly those located at the tops of walls that could be subjected to heat from a pool fire, should include reinforcement that is either lapped, welded or suitably anchored (BS EN 1504-9:2008 Method 4.2) to the existing wall to form a proper reinforced repair, preventing the 'plug' of concrete from detaching.

Corrosion damage to the wall can be repaired by one of many methods listed under Principles 7 to 11 in BS EN 1504-9:2008, but patch repair (BS EN 1504-9:2008 Method 7.2) is the most common. This method requires identification of the cause of corrosion (eg low cover, carbonation, chloride penetration) and then requires contaminated concrete to be removed, reinforcement cleaned and then new material added to restore the passive (non-corroding) state of the affected bars. If significant section loss has occurred to the reinforcement, then additional bar may need to be added to restore the structural capacity in critically loaded structural situations (eg base of walls).

A general guide to repair techniques is provided in Appendix A10.

12.2.3 Surface protection

Containment needs can change, particularly with changes in ownership, but concrete bunds remain a flexible and adaptable means of containment and can be upgraded to provide additional surface protection to the concrete.

As discussed earlier, various chemicals can attack the unprotected concrete surface. Concrete Society (1997) provides practical guidance on the selection, application and workmanship required for the successful application of surface protection systems to concrete. ACI (1985) gives a particularly detailed summary of the effect of chemicals on concrete.

Guidance on specification of products and systems for surface protection systems is given in BS EN 1504-2:2004. This gives performance requirements for products and systems to protect concrete against physical (BS EN 1504-9:2008 Method 5.1) and chemical (BS EN 1504-9:2008 Method 6.1) exposure. Requirements for the preparation of the concrete, application and quality control of the works are set out in BS EN 1504-10:2003

Careful consideration needs to be given to joint design to ensure enhanced surface protection is maintained across joints and any cracks in the concrete, which will often need to be specially reinforced to prevent reflective cracking through the paint film.

12.3 GENERAL MAINTENANCE AND REPAIR OF EARTH BANKED CONTAINMENT BASINS, EARTH BUNDS AND EARTH FLOORS

12.3.1 Defects

Defects to earthworks can occur for a number of reasons:

- Slumping or slope failure – the face or slope of the earth embankment becomes unstable (slips) due to changes in loading and/or moisture content.
- Settlement – weight of the embankment causing consolidation of the underlying soils.
- Subsidence – decrease in moisture content causing the underlying soils to shrink (this is generally confined to clayey soils).
- Heave – increase in moisture content causing the underlying soils to swell (this is generally confined to clayey soils and is most likely to affect earth-floored lagoons).
- Desiccation – soils dry out sufficiently to crack.
- Erosion.
- Animal burrows.

With the exception of erosion and animal burrows, these defects are generally symptomatic of flaws in the geotechnical design of the earthworks and the design of any remedial works should be completed by a competent person.

12.3.2 Repair techniques

Where an earth embankment has slumped, it should be reconstructed. If there are no apparent reasons why the embankment has failed, eg it has been subjected to greater loading than anticipated, the design should be reviewed before reconstruction (see Section 8.2).

If the crest of the embankment has settled over a relatively short period of time (several months) after construction and has then halted, then it is possible that no further consolidation will occur and the crest can simply be raised using the same soils and method of construction as for the original works. However, if the settlement is ongoing over a considerable period of time, it is likely that the embankment will have to be redesigned and replaced.

Subsidence and heave are fundamental properties of the underlying soils and if these occur, specialist geotechnical advice should be sought.

Where soils become desiccated, the only likely remedies are to prevent moisture loss by covering with a liner, or a suitable thickness of soils that are not prone to desiccation.

Erosion of soils by wind and rain can be minimised by ensuring that a good sward of grass cover is maintained. Where erosion is caused by vehicular or pedestrian movements, these movements should be prevented, or the embankment protected by providing a formally paved surface, or using a proprietary reinforcement product such as Grasscrete or similar products.

Burrowing animals should be deterred by protecting the faces of the embankment (see Section 8.8).

Where a section of embankment has to be replaced, it should be constructed using the same soils and method of construction as for the original works and tied into the existing bund as shown in Figure 12.2.

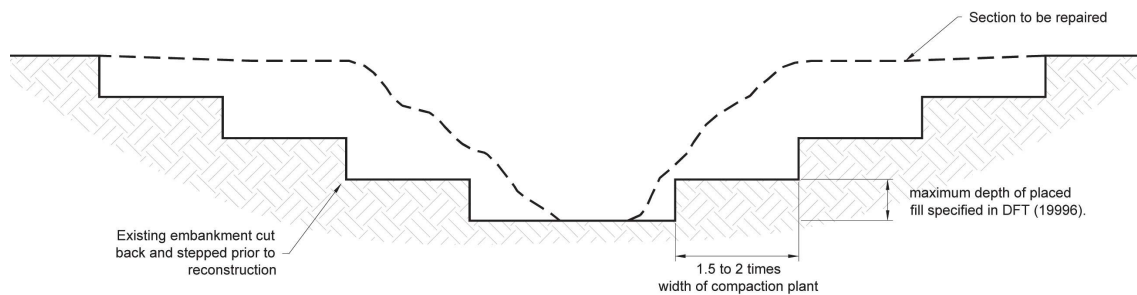

Figure 12.2 Tying into existing earthworks

12.4 MODIFICATIONS TO EXISTING BUND WALLS

Where a facility is to be extended, the construction of any new sections of bund wall that may be required should follow the guidance in Chapters 7 or 8 as appropriate.

Increasing the capacity of a containment facility can be achieved by raising the bund wall. However, for reinforced concrete and blockwork walls, the overall height should not exceed 1.5 m for the safety reasons set out in Section 6.3.1. Bund volume can also be increased by expanding bund area using a new section of bund. However, this can increase fire risk if it increases potential pool size, but the risk can be minimised by retaining a dividing wall between old and new bund areas. All such modifications must be designed to the same standards as the rest of the construction and built by an appropriately experienced contractor to ensure the works follow the guidance in this publication.

Before raising the crest of an existing reinforced concrete and blockwork wall, it should first be established that the wall has sufficient strength to cater for the additional loading that would be applied. For an earth embankment wall, slope stability issues should first be considered.

The additional height of wall should be tied into the existing reinforced concrete or blockwork wall by grouting in reinforcement 'starter' or 'dowel' bars at appropriate centres and anchorage depths. Anchoring resins should comply with BS EN 1504-6:2006 (BS EN 1504-9:2008 Method 4.2) and the crest of the existing walled should be scabbled and cleaned to facilitate a good bond. It may be appropriate to use a bonding agent specified in accordance with BS EN 1504-4:2004 (BS EN 1504-9:2008 Method 4.4).

12.5 DRAINAGE AND TRANSFER SYSTEMS

In situ repair techniques for pipelines can be found in WRc (2001):

- glassfibre concrete and glass reinforced plastic linings, which are bonded to the interior of existing pipes
- non-bonded lining systems such as PE pipes or thermosetting resin and other plastic liners inserted within the old pipe
- lightweight GRP or resin plastic liners used as annular formwork for injected grout.

It is important to note that these *in situ* repairs can reduce the capacity of the pipeline, however, the loss of capacity is often offset at least in part by the improved flow characteristics (reduced roughness) of the lining system.

Lining a pipe with a chemically resistant lining system can provide a means of upgrading the class of a transfer system.

The advice of a specialist contract should be sought on techniques appropriate to the nature of the site and the condition of the existing system.

12.6 JOINTS

Assuming that the bund wall has sufficient strength to cater for the design loading, it is likely to be the fire resistance of the joints, waterstops and penetrations that give rise to the greatest concern with respect to the performance of the containment system during an incident involving flammable inventory. The failure of the joints and issues with pipe penetrations were identified by HSE (2009a) as contributing factors to the loss of containment.

Waterstops should have been installed in all new walls built to CIRIA R164 and BS 8007:1987 standards. They should be installed in the centre of walls across movement joints, with rear-facing waterstops installed beneath slab joints, to provide the most effective way of minimising leakage from bund joints.

As set out in Section 5.6.1, where an existing facility is assessed and joints are shown not to comply with the guidance, then measures are needed to upgrade the performance of the joints. Even where a burning inventory is not a risk, successful containment of liquids will require waterstops across movement joints, as mastic sealants cannot be relied upon as a sole line of defence for the joint. Even if the sealant installation is to a high standard, the cyclic movement of the joint will lead to failure of the sealant over time, in itself demanding regular and careful inspection and replacement of sealants. Some form of flexible waterstop is required in addition to the sealant.

It is an easier task to provide a retrofitted flexible waterstop system across movement joints that will not be subject to fire. Flexible sheeting can be bonded to the concrete surface across the joint to provide a watertight and chemically-resistant seal. In areas subject to trafficking, the seal will need protection against damage.

Where there is a current or future risk of escape accompanied by fire, then where practicable, existing joints should be upgraded to provide fire resistant waterstops (normally metal) within the concrete and/or fireproof joints. However it is recognised that retrofitting waterstops to existing bund wall joints is not a simple task and may ultimately degrade the joint integrity.

Table 12.1 lists a range of possible existing bund wall joint arrangements and reviews product resistance, fire resistance and upgrade options for each arrangement drawn from HSE (2009a). This applies principally to the containment of potentially flammable inventory.

A typical detail of a plated joint is provided in Figure 12.3.

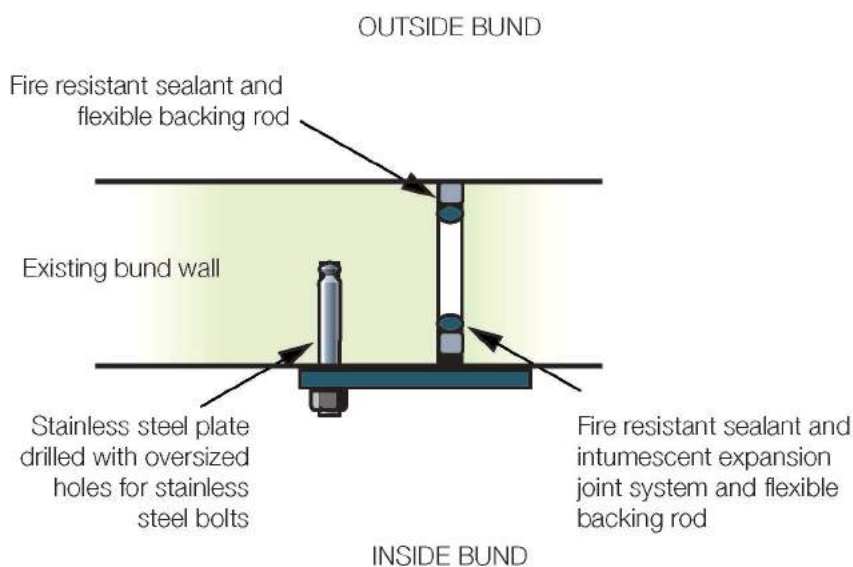

Figure 12.3 Wall plate joint detail (from HSE, 2009)

Table 12.1 Upgrade options for joints (from HSE, 2009)

Description	Commentary	Action
A joint with a stainless steel waterstop and fire and product resistant sealants	This meets current good practice and no upgrade would be required It is unlikely to have a significant rate of liquid egress from the joint during an incident, with or without fire	None
A joint with a plastic waterstop and stainless steel cover plate designed to ensure product and fire resistance to BS 476-10:2009	This meets current good practice and no upgrade would be required It is unlikely to have a significant rate of liquid egress from joint although loss of integrity of the plastic waterstop may eventually occur after protracted heat exposure	None
A joint with no waterstop but with a stainless steel cover plate, with product and fire resistant sealants designed to ensure fire resistance to BS 476-10:2009	This joint may be considered to be fire resistant and would be considered impermeable (liquid tight) while the product-resistant sealant remains in good condition Leakage rate through movement of the joint would also be expected to increase with sealant ageing	Frequent sealant inspection and replacement routines should be in place to ensure sealants remain in a good condition
A joint with no waterstop, no cover plate but with product- and fire-resistant sealant	This joint only provides limited fire resistance and is impermeable only when the product resistant sealant remains in good condition. Leakage rate through movement of the joint would be expected to increase with sealant ageing	As a minimum, this should be upgraded with a stainless steel cover plate and inspection and replacement routines shall be in place to ensure sealants remain in good condition
A joint with product-resistant sealant but no waterstop, no stainless steel cover plate and no fire resistant sealants	This joint will be impermeable while the sealant remains in good condition but is not fire resistant, and would be expected to leak rapidly following a fire Leakage rates through movement of the joint would be expected to increase with sealant ageing	As a minimum, this joint should be upgraded with a stainless steel cover plate and fire resistant sealants. In addition, inspection and replacement routines shall be in place to ensure sealants remain in good condition

12.7 PIPE PENETRATIONS

12.7.1 Introduction

Pipes should not penetrate through the slab and all such configurations should be re-routed over the bund walls and the holes through the slab sealed (see Section 12.2.2).

Typical penetrations at existing sites include a 'straight through', 'puddle flange' and 'sleeved' arrangement (see Figure 12.4).

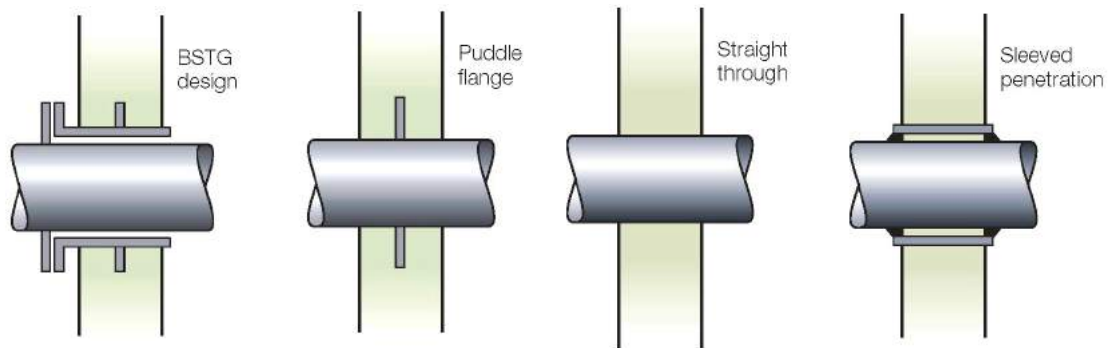

Figure 12.4 Typical bund penetrations (from HSE, 2009a)

The upgrading of existing pipe penetrations to provide a liquid tight, fire proof corrosion free joint is difficult to achieve. Any upgrade should be carefully reviewed to ensure that the upgraded penetration does not affect pipe flexibility and integrity, or that excessive forces are not exerted on the wall by

expanding pipework. Any proposal to upgrade an existing penetration should be assessed against the duty holder's obligation to reduce risk sufficiently to satisfy the law and in discussion with the regulator.

Where such an assessment considers the existing joints not to be fire resistant or leak tight, several upgrade options are provided in the following sections.

12.7.2 Straight through

Where existing pipes run through bund walls there is a possibility that corrosion crevices exist between the pipe and the wall.

One option is to bolt a steel fire protection plate (split for installation) sealed with fire/chemical resistant sealant. This is similar in principle to the steel plates for expansion joints covered in the next section. Split plates can be installed by cold methods without the need for removing the pipeline from service for modification and welding (see Figure 12.5).

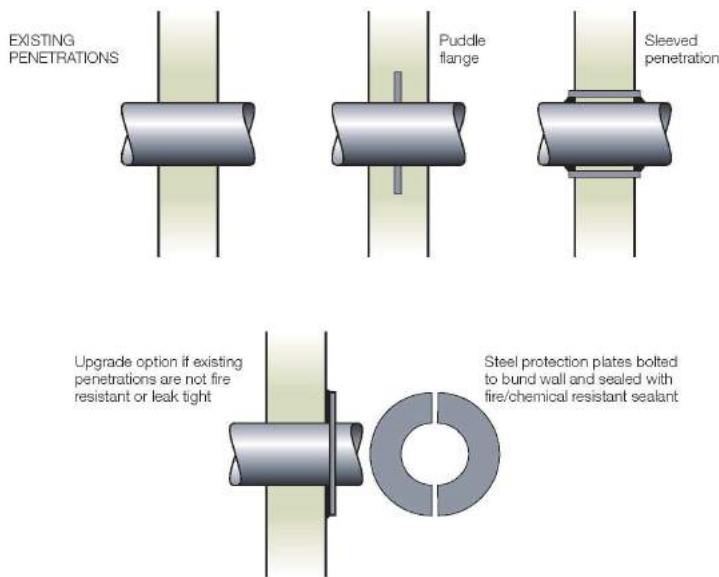

Figure 12.5 Steel split fire protection plate (from HSE, 2009a)

A second upgrade option is to reduce the pipe size (only local to the penetration) and use the existing pipe as a sleeve, which can then be sealed using a fire resistant sealant and protected on the inside face with a steel protection ring (see Figure 12.6).

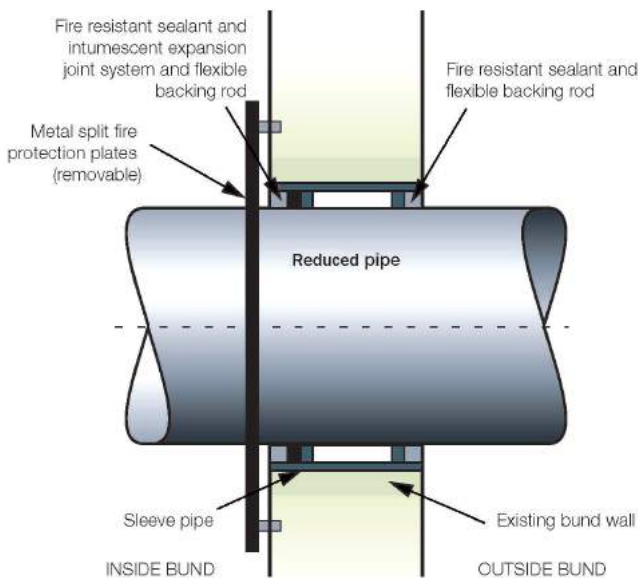

Figure 12.6 Sealed sleeve upgrade option (after HSE, 2009a)

Provided it was installed correctly, the puddle flange is inherently leak and fire proof. However, because it anchors the pipe to the wall, it can result in significant loads on the wall or tank during an incident, or buckling forces in pipes and joints, due to thermal expansion. Additional pipe block anchors may be needed to prevent long lengths of pipe generating high pressures.

12.7.3 Sleeved

Existing sleeved penetrations can be upgraded if required to include a fire resistant sealant and a split fire protection plate (see Figure 12.6).

12.8 WAREHOUSES

A significant proportion of pollution incidents involve fires in warehouses resulting in the release of inventory and/or contaminated firefighting water into the environment. This section provides advice on how the fabric of an existing warehouse can be modified to enhance containment.

In many cases the fabric of the building, ie the floor slab and the walls, has the potential to contain spillages of inventory. However, warehouse walls (if present) will be normally constructed from blockwork or brickwork and therefore would only be suitable for class 1 containment. Where class 2 or class 3 containment is required, bund walls, either internal, or external, to the warehouse will have to be constructed in accordance with Chapter 7.

Clearly, bunding the entire perimeter of a warehouse will potentially compromise access. Where the containment volume (see Chapter 4) is low enough, 'rollover' ramps (similar to speed humps may provide a solution. However, where this is not practical, bunds local to the stored inventory may be required. Internal bunds within a warehouse can also help limit the spread of spillages.

In addition to doorways, potential pathways should be identified and sealed. These might include:

- internal drainage (floor gullies, internal downpipes etc)
- defects in the floor slab
- service penetrations.

Where potentially corrosive inventory is stored, floor slabs might require protective coating. Where combustible inventory is required, floor joints may require upgrading (see Section 12.6).

Escape of inventory down the internal face of cladding from a jetting failure or similar of the primary containment can be prevented by installing splash guards/deflector plates to direct spillage to within the containment.

Where it is impractical to provide sufficient containment within the warehouse, it may be possible to provide remote secondary and/or tertiary containment by permanent or temporary bunding of external areas of hardstanding, eg car parks. The practicality of this option will depend on a number of issues including topography and availability of land (see Section 11.2).

Case study 12.1 is an example of how an existing warehouse was adapted to provide both secondary and tertiary containment.

Case study 12.1
Adaption of an existing warehouse, UK

Abbey Metal Finishing Company Ltd (Amfin) provides a metal surface finishing service to the aerospace and general industrials sectors. The 40 finishing operations include plating, anodizing treatments, painting, and plasma spraying involving a number of chemicals that are potentially hazardous to the environment. The site falls within the scope of COMAH 1999.

In April 2010, a large fire broke out at the premises. Fire crews attended and used a considerable amount of water to fight the fire. However, despite the best efforts of the Fire and Rescue Service using pollution prevention equipment (PPE), much of this firefighting water was contaminated with a cocktail of hazardous substances used in metal treatment that had entered the adjacent River Anker.

The incident resulted in approximately 27 000 fish deaths along a 6 km stretch of river and Amfin was subsequently charged for failing to take measures to prevent major accidents and limit their consequences to the environment. They had earlier pleaded guilty at Nuneaton Magistrates' Court. In particular, the emergency plan had failed as there were inadequate arrangements on site to contain the firewater, and no prior arrangements to access the sewerage system for emergency storage or tanker contaminated water off site.

Rather than rebuild the premise, a new site was sought that could be developed to provide a comprehensive containment strategy.

All chemical processing and undiluted process chemistry now used and stored within an internal secondary containment bund. The bund is epoxy coated to withstand chemical degradation, has no connection with foul of surface drainage and is permanently sealed. Quarterly preventative maintenance checks have been instigated on the site and repairs are carried out on the bund when issues are found. This bund has been designed to contain 125 per cent of the entire process chemistry within it and provides a secondary containment volume of 143 000 litres.



In addition, the external tertiary containment bunds have been constructed around the perimeter boundary to contain firefighting water and surface water runoff within the lower part of the sloping site. The external bund provides tertiary containment for 360 000 litres of firefighting water and has 538 000 litres of surface water runoff (based on the estimated depth of rainfall assuming a one per cent AEP event occurs during an incident). The total site containment available is some 981 000 litres.

Surface water runoff from the site, including the tertiary containment area, is drained to the Harrow Brook, which flows beyond the site boundary. During an incident, the tertiary containment is mobilised by the automatic activation of surface water shut-off valves triggered by a fire alarm, a power cut or by manual activation remote from the valve location. Foul sewer and surface water covers within the tertiary containment area are permanently sealed to prevent unauthorised release of firefighting water or stormwater into these systems.

In addition, an emergency contract has been taken out with Veolia Environmental that provides the attendance of tankers on site within an hour to pump out accumulated firefighting water and/or rainwater from within the secondary or tertiary containment bunds.

References

- ACI (2013) *Guide to selecting protective treatments for concrete*, ACI515.2R-13. American Concrete Institute, Farrington Hill, MI, USA (ISBN: 978-0-87031-825-2). Go to: www.concrete.org/Home.aspx
- API (2005) *Welded storage tanks for oil storage*, API650 10th edition, Addendum 4 American Petroleum Institute, USA. Go to: www.api.org
- ATHERTON, W (2005) *An experimental investigation of bund wall overtopping and dynamic pressures on the bund wall following catastrophic failure of a storage vessel*, Research Report 333, Health and Safety Executive, London. Go to: www.hse.gov.uk/research/rrpdf/rr333.pdf
- BAILLI (1993) *Cambridge Water Company (Respondents) v. Eastern Counties Leather plc (Appellants) Judgement UKHL, 12 (09) December 1993*, British and Irish Legal Information Institute, UK. Go to: www.bailii.org/uk/cases/UKHL/1993/12.html
- BSTG (2006) *Initial Report to the Health and Safety Commission and the Environment Agency of the investigation into the explosions and fires at the Buncefield oil storage and transfer depot, Hemel Hempstead, on 11 December 2005*, Buncefield Major Incident Investigation Board (BMIIB), Buncefield Major Incident Investigation, London. Go to: www.buncefieldinvestigation.gov.uk/reports/initialreport.pdf
- BSTG (2007) *Safety and environmental standards for fuel storage sites, Buncefield Standards Task Group (BSTG) Final Report*, Buncefield Major Incident Investigation Board (BMIIB), Buncefield Major Incident Investigation, London. Go to: www.hse.gov.uk/comah/buncefield/bstgfinalreport.pdf
- BSTG (2008a) *The Buncefield Incident 11 December 2005: The final report of the Major Incident Investigation Board. Volume 1*, Buncefield Standards Task Group, Buncefield Major Incident Investigation, London. Go to: www.buncefieldinvestigation.gov.uk/reports/volume1.pdf
- BSTG (2008b) *The Buncefield Incident 11 December 2005: The final report of the Major Incident Investigation Board. Volume 2*, Buncefield Standards Task Group, Buncefield Major Incident Investigation, London. Go to: www.buncefieldinvestigation.gov.uk/reports/volume2a.pdf
- BSTG (2008c) *Recommendations on the emergency preparedness for, response to and recovery from incident*, Buncefield Standards Task Group, Buncefield Major Incident Investigation, London. Go to: www.buncefieldinvestigation.gov.uk/reports/volume2b.pdf
- BUNGEY, J H, GRANTHAM, M G and MILLARD, S (2006) *Testing of concrete in structures*, fourth edition, Taylor & Francis, New York, USA (ISBN: 978-0-41526-301-6)
- CA (2008a) *COMAH Competent authority policy on containment of bulk hazardous liquids at COMAH establishments. Control of Major Hazard (COMAH) Regulations 1999*, Competent Authority (comprising HSE, SEPA, NRW and the Environment Agency). Go to: <http://tinyurl.com/ncvclon>
- CA (2008b) *Containment of bulk hazardous liquids at COMAH establishments containment policy. Supporting guidance for secondary and tertiary containment*, Competent Authority (comprising HSE, SEPA, NRW and the Environment Agency). Go to: <http://tinyurl.com/perms6o>
- CA (2008c) *Containment of bulk hazardous liquids at COMAH establishments Containment policy. Supporting guidance for secondary and tertiary containment and implementation principles for regulators*, Competent Authority (comprising HSE, SEPA, NRW and the Environment Agency). Go to: <http://tinyurl.com/p3eu4as>
- CA (1999) *Guidance for environmental assessment of COMAH safety reports*, SRAM Section 13, Competent Authority (comprising HSE, SEPA, NRW and the Environment Agency). Go to: www.hse.gov.uk/comah/guidance/sram.pdf
- CA (in press) *"All measures necessary" – environmental aspects (guidance for competent authority inspectors and operators)*, Competent Authority (comprising HSE, SEPA, NRW and the Environment Agency). Go to: www.hse.gov.uk/comah/

CASSIES, S and SEALE, L (2003) *Chemical storage tank systems – good practice. Guidance on design, manufacture, installation, operation, inspection and maintenance*, C598, CIRIA, London (ISBN: 978-0-86017-598-8). Go to: www.ciria.org

CDOIF (2013a) *Guidance for environmental risk tolerability for COMAH establishments*, Chemical and Downstream Oil Industry Forum. Go to: <http://tinyurl.com/ofnafm5>

CDOIF (2013b) *CDOIF guidance – leak detection*, Chemical and Downstream Oil Industries Forum. Go to: www.hse.gov.uk/aboutus/meetings/committees/cif/leak-detection-guide.pdf

CEH (2000) *Flood Estimation Handbook CD-ROM*, Centre for Ecology & Hydrology, Wallingford (ISBN: 978-1-90669-80-03). Go to: www.ceh.ac.uk/feh2/fehintro.html

CHOW, V T, MAIDMENT, D R and MAYS, L W (1988) *Applied hydrology*, P34, McGraw-Hill Book Company, Singapore (ISBN: 0-07010-810-2)

CIRIA (1991) *Manual of good practice in sealant application*, SP80, CIRIA, London (ISBN: 978-0-86017-324-3). Go to: www.ciria.org

CIRIA, MINISTRY OF ECOLOGY, USACE (2013) *International Levee Handbook*, C731, CIRIA, London (ISBN: 978-0-86017-734-0). Go to: www.ciria.org

CLARKE, J L (2009) *Historical approaches to the design of concrete buildings and structures*. TR70, Concrete Society, Camberley (ISBN: 978-1-904482-57-4). Go to: www.concrete.org.uk/publications_tr.asp

CONCRETE SOCIETY (1997) *Guide to surface treatments for protection and enhancement of concrete*, TR50, Concrete Society, Camberley. Go to: www.concrete.org.uk/publications_tr.asp

CONCRETE SOCIETY (2008) *Concrete practice - guidance on the practical aspects of concreting*, GCG8, Concrete Society, Camberley. Go to: www.concrete.org.uk/publications_tr.asp

CONCRETE SOCIETY (2009a) *External in-situ concrete paving*, TR66, Concrete Society, Camberley. Go to: www.concrete.org.uk/publications_tr.asp

CONCRETE SOCIETY (2009b) *Repair of concrete structures with reference to BS EN 1504*, TR69, Concrete Society, Camberley. Go to: www.concrete.org.uk/publications_tr.asp

CONCRETE SOCIETY (2010) *Non-structural cracks in concrete*, TR22, Concrete Society, Camberley. Go to: www.concretebookshop.com/tr22-non-structural-cracks-in-concrete-1779-p.asp

CONCRETE SOCIETY (2013) *Visual concrete – control of blemishes*, CS172, Concrete Society, Camberley. Go to: www.concretebookshop.com/visual-concrete-control-of-blemishes-4132-p.asp

CRONIN, P S and EVANS, J A (2009) *A series of experiments to study the spreading of liquid pools with different bund arrangements*, CRR 405/2002, Health and Safety Executive, London (ISBN: 0-71762-255-X). Go to: www.hse.gov.uk/research/crr_pdf/2002/crr02405.pdf

BLACK, E, GORMLEY, A, POLLARD, S, ROCKS, S (2011) *Guidelines for environment risk assessment and management. Green Leaves III*, PBI 3670, Department for the Environment, food and Rural Affairs, London. Go to: <http://tinyurl.com/q33kp8t>

BLAND, C E G (1995) *Bedding construction and flow capacity of vitrified clay pipelines*, Clay Pipe Development Association Limited, Chesham, Buckinghamshire

CPSA (2011) *Technical guidance 2 – Installation: pipes*, Concrete Pipeline Systems Association, Leicester. Go to: www.concretepipes.co.uk/

DCLG (2008) *Fire and Rescue Manual, Volume 2 Fire Service operations environmental protection*, Department for Communities and Local Government, London (ISBN: 978-0-11341316-4). Go to: <http://tinyurl.com/qdfqnnk>

DEFRA (1998) *Yellow Code. Code of Practice for suppliers of pesticides to agriculture, horticulture and forestry (Yellow Code)*, Department for the Environment Food and Rural Affairs, London. Go to: www.pesticides.gov.uk/Resources/CRD/Migrated-Resources/Documents/Y/yellow_code.pdf

DEFRA (2010) *The Water Resources (Control of Pollution) (Silage, Slurry and Agricultural Fuel Oil) (Wales) Regulations 2010 “the SSAFO Wales Regulations”. Guidance notes for farmers*, Department for the Environment, Food and Rural Affairs, London. Go to: <http://tinyurl.com/p3w4qk4>

- DEFRA (2011) *Green Leaves III. Guidelines for Environmental risk assessment and management*, Department for the Environment, Food and Rural Affairs, London. Go to: <http://tinyurl.com/q33kp8t>
- DEFRA (2013) *Environment Permitting Guidance. Core guidance for the environment Permitting (England and Wales Regulations 2010)*, Department for the Environment, Food and Rural Affairs, London. Go to: <http://tinyurl.com/opm4lzx>
- DfT (1999a) *Design Manual for Roads and Bridges. Volume 7, Pavement design and maintenance*, Department for Transport, London. Go to: <http://dft.gov.uk/ha/standards/dmrb/vol7/index.htm>
- DfT (1999b) *Manual of Contract Documents for Highway Works (MCHW). Volume 1 Specification for highway works, Series 600, Earthworks*, Department for Transport, London. Go to: <http://tinyurl.com/pxmvhxj>
- DETR (1998) *Management of harm to the environment: Criteria for the management of unplanned releases*, Department of the Environment, Transport and the Regions, London (ISBN: 978-0-11753-456-8)
- DRISCOLL, R, SCOTT, P and POWELL, J (2008) *EC7 – implications for UK practice*, C641, CIRIA, London (ISBN: 987-0-086017-641-1). Go to: www.ciria.org
- EA (2009a) *Using geomembranes in landfill engineering*, LFE5, Environment Agency, Bristol. Go to: <http://cdn.environment-agency.gov.uk/geho0409bpmh-e-e.pdf>
- EA (2009b) *Geophysical testing of geomembranes used in landfills*, LFE8, Environment Agency, Bristol. Go to: www.environment-agency.gov.uk
- EA (2012) *Good practice for decommissioning redundant boreholes and wells*, Environment Agency, Bristol. Go to: www.environment-agency.gov.uk
- EA (2013a) *Groundwater protection: Principles and practice*, GP3, Environment Agency, Bristol. Go to: www.environment-agency.gov.uk
- EA (2013b) *How to comply with your environmental permit*, version 6, Environment Agency, Bristol. Go to: <http://tinyurl.com/kckjunm>
- EA, NIEA, SEPA (2007) *Pollution Prevention Guidelines (PPG) 28 Controlled burn*, Environment Agency, Scottish Environment Protection Agency, Northern Ireland Environment and Heritage Service, UK. Go to: <http://tinyurl.com/nugpzp9>
- EA, NIEA, SEPA (2009) *Pollution Prevention Guidelines (PPG) 21: Incident response planning*, Environment Agency, Northern Ireland Environment Agency and the Scottish Environment Protection Agency. Go to: <http://www.doeni.gov.uk/niea/ppg21.pdf>
- EA, NIEA, SEPA (2000) *Pollution Prevention Guidelines (PPG) 18 Managing fire water and major spillages*, Environment Agency, Northern Ireland Environment Agency and the Scottish Environment Protection Agency. Go to: <http://tinyurl.com/nugpzp9>
- EA, NIEA, SEPA (2004) *Pollution Prevention Guidelines (PPG) 26 Storage and handling of drums and intermediate bund containers*, Environment Agency, Northern Ireland Environment Agency and the Scottish Environment Protection Agency. Go to: <http://tinyurl.com/qbsm6nu>
- EA, NIEA, SEPA (2011a) *Pollution Prevention Guidelines (PPG) 2 Above ground oil storage tanks*, Environment Agency, Northern Ireland Environment Agency and the Scottish Environment Protection Agency. Go to: <http://tinyurl.com/qgdrxo8>
- EA, NIEA, SEPA (2011b) *Pollution Prevention Guidelines (PPG) 22 Dealing with spills*, Environment Agency, Northern Ireland Environment Agency and the Scottish Environment Protection Agency. Go to: <http://tinyurl.com/nnhx25c>
- EDWARDS, P (1992) *Dangerous substances in water: a practical guide*, Environmental Data Services Ltd, UK (ISBN: 978-0-90767-305-7)
- EEMUA (2003) *Users' guide to the inspection, maintenance and repair of above ground vertical cylindrical steel storage tanks*, EEMUA 159, Engineering Equipment and Materials Users' Association, London. Go to: www.eemua.co.uk

- EI (2007) *Environmental guidelines for petroleum distribution installations*, Energy Institute, London.
Go to: www.energypublishing.org
- EI (2009) *Environmental risk assessment of bulk liquid storage facilities: a screening tool*, Energy Institute, London. Go to: www.energypublishing.org
- EI (2010) *High level framework for process safety management*, Energy Institute, London (ISBN: 978-0-85293-584-2). Go to: www.energypublishing.org
- EI (2013) *Guidance on risk assessment and design of tertiary containment systems for bulk storage of petroleum, petroleum products, or other fuels*, Energy Institute, London. Go to: www.energypublishing.org
- EI (2012) *Model code of safe practice. Part 19: Fire precautions at petroleum refineries and bulk storage installations*, Energy Institute, London. Go to: www.energypublishing.org
- EI (2013a) *Model code of safe practice. Part 2: Design, construction and operation of petroleum distribution installations*, Energy Institute, London. Go to: www.energypublishing.org
- EI (2013b) *Guidance on conceptual design, selection and life cycle assurance of liners intended to improve integrity of bunds to above-ground storage tanks for bulk storage of petroleum, petroleum products or other fuels* (ISBN: 978-0-85293-671-9). Go to: www.energypublishing.org
- EI (2014) *Guidance on conceptual design, selection and life cycle assurance of liners intended to improve integrity of bunds to above-ground storage tanks for bulk storage of petroleum, petroleum products or other fuels*, Energy Institute, London. Go to: www.energypublishing.org
- ENDS (1993) "News article", Report No 227, P43, Environmental Data Services, London
- EPA (1995) *Fire-water retention facilities. (Draft) Guidance note to industry on the requirements for fire-water retention facilities*, Environmental Protection Agency, Wexford.
Go to: www.epa.ie/pubs/advice/licensee/Draft%20firewater%20retention.pdf
- EUROPEAN COMMISSION (2006) *Integrated Pollution Prevention and Control. Reference document on Best Available Techniques on emissions from storage*, European Commission, Brussels. Go to: <http://tinyurl.com/kr6xncq>
- FORDE, M C (2009) *ICE Manual of construction materials. Volume 1 Fundamentals and theory, metals and alloys*. Thomas Telford, London (ISBN: 978-0-72773-597-3)
- GABA, A R, SIMPSON, B, POWRIE, W and BEADMAN, D R (2003) *Embedded retaining walls – guidance for economic design*, C580, CIRIA, London (ISBN: 978-0-86017-580-3). Go to: www.ciria.org
- GANGOLLI, S (1999) *The Dictionary of Substances and their Effects (DOSE)*, Royal Society of Chemistry, UK (ISBN: 978-0-85404-803-8). Go to: www.rsc.org/Publishing/CurrentAwareness/DOSE/index.asp
- GRANTHAM, M G (2011) *Concrete repair. A practical guide*, first edition, Taylor & Francis UK (ISBN: 978-041544-734-8)
- GREENSPAN, H P and YOUNG, R E (1978) "Flow over a containment dyke", *Journal of Fluid Mechanics*, vol 87, 1, Cambridge University Press, pp 179–192
- HANLON, D and MCGLASHAN, B (2008) *Fire and Rescue Manual. Volume 2 Fire Service Operations, Environmental Protection*, Communities and Local Government. Go to: <http://tinyurl.com/qdfqnnk>
- HEWLETT, H W M, BOORMAN, L A, and BRAMLEY, M E (1997) *Design of reinforced grass waterways*, R116, CIRIA, London (ISBN: 978-0-86017-285-7). Go to: www.ciria.org
- HM GOVERNMENT (2010) *The Building Regulations. Approved Document H, Drainage and waste disposal*, Crown Copyright, London (ISBN: 978-1-85946-208-9).
Go to: www.planningportal.gov.uk/uploads/br/BR_PDF_AD_H_2010.pdf
- HOOPER, R, ARMITAGE, R, GALLAGHER, K A and OSORIO, T (2009) *Whole-life infrastructure asset management: good practice guide for civil infrastructure*, C677, CIRIA, London (ISBN: 978-0-86017-677-0).
Go to: www.ciria.org
- HSE (1996) *Safe use and handling of flammable liquids*, HSG140, Health and Safety Executive, London (ISBN: 978-0-71760-967-3)

- HSE (1998a) *The storage of flammable liquids in containers*, HSG51, Health and Safety Executive, London (ISBN: 978-0-71761-471-4)
- HSE (1998b) *The storage of flammable liquids in tanks*, HSG176, Health and Safety Executive, London (ISBN: 978-0-71761-470-7)
- HSE (1999) *Emergency planning for major accidents*, HSG191, Health and Safety Executive, London (ISBN: 978-0-71761-695-4)
- HSE (2007a) *Technical Measures Document. Secondary containment*, Health and Safety Executive, London. Go to: www.hse.gov.uk/comah/sragtech/techmeascontain.htm
- HSE (2007b) *Technical Measures Document. Emergency response spill control*, Health and Safety Executive, London. Go to: www.hse.gov.uk/comah/sragtech/techmeasspill.htm
- HSE (2009a) *Safety and environmental standards for fuel storage sites, Process Safety Leadership Group (PSLG), Final report*, Health and Safety Executive, London (ISBN: 978-0-71766-386-6)
- HSE (2009b) *Chemical warehousing, the storage of packaged dangerous substances*, HSG71, Health and Safety Executive, London (ISBN: 978-0-71766-237-1)
- HSE (2011) *Buncefield: Why did it happen? The underlying causes of the explosion and fire at the Buncefield oil storage depot*, Hemel Hempstead, Hertfordshire on 11 December 2005, COMAH Competent Authority (HSE, EA, SEPA), UK. Go to: www.hse.gov.uk/comah/buncefield/buncefield-report.pdf
- HSE (2012) *Competent authority guidance for inspectors on emergency arrangement for COMAH establishments*, The COMAH Competent Authority (HSE, EA, SEPA), UK. Go to: <http://tinyurl.com/krlujp4>
- HSE, EA, SEPA (2008) *COMAH Competent Authority Policy on containment of bulk hazardous liquids at COMAH establishments. Control of Major Accident Hazard (COMAH), Regulations 1999*, Health and Safety Executive, UK. Go to: www.comah.org/wp-content/uploads/2013/09/COMAH-Containment-Policy.pdf
- HSE, EA, SEPA (2010) *COMAH Competent Authority Workstream. Secondary and tertiary containment of bulk hazardous liquids at COMAH Establishments (operational delivery guide)*, Health and Safety Executive, UK. Go to: www.hse.gov.uk/comah/guidance/bulk-hazardous-liquids.pdf
- HSL (in press) *Major accidents to the environment (MATTE): UK case studies of incidents and near misses 1999–2010*, Health and Safety Laboratory, HSE, UK HR WALLINGFORD (1986) *Design and analysis of urban storm drainage – The Wallingford Procedure*, National Water Council, London
- ICI (1986) *Water supply systems for fire fighting and fire protection*, Fire Protection Guide No. 5, ICI, UK
- IMO (2014) *Pollution prevention*, International Maritime Organization, London
Go to: www.imo.org/OurWork/Environment/PollutionPrevention/Pages/Default.aspx
- INSTITUTION OF CIVIL ENGINEERS (2009) *ICE Manual of Construction Materials: Volume 1 Fundamentals and theory, metals and alloys*, Thomas Telford, London (ISBN: 978-0-72773-597-3)
- INSTITUTE OF HYDROLOGY (1975) *Flood studies report*, Natural Environment Research Council, Swindon, UK
- LOCAL GOVERNMENT ASSOCIATION and WATER UK (2007) *The National guidance document on the provision of water for fire fighting*, third edition, Local Government Association and Water UK, London. Go to: <http://tinyurl.com/m8bwatz>
- MASON, P A (1992) *Farm waste storage: guidelines for construction*, R126, CIRIA, London (ISBN: 978-0-86017-352-6). Go to: www.ciria.org
- MASON, P A, AMIES, H J, EDWARDS, P R, ROSE, G and SANGARAPILLAI, G (1997) *Design of containment systems for the prevention of water pollution from industrial incidents*, R164, CIRIA, London (ISBN: 978-0-86017-476-9). Go to: www.ciria.org
- OChemOnline (2011) *H-Phrases*. Go to: www.ochemonline.com/H_phrases
- QUEENSLAND GOVERNMENT (2007) *Narangba Industrial Estate: Multi-agency fire and firewater risk minimisation inspection program*, Department of Emergency services, Environmental Protection Agency, Caboolture Shire Council. Go to: www.emergency.qld.gov.au/publications/pdf/inter_agency_report.pdf

- SCOTTISH WATER (2004) *Water bye-laws 2004*, Scottish Water, Edinburgh. Go to: <http://tinyurl.com/ogloucy>
- SEPA (2014) *Information on types of tanks for oil storage*, Scottish Environment Protection Agency, Stirling, Scotland. Go to: <http://tinyurl.com/ofqnefj> (accessed April 2014)
- SUTCLIFFE, J V (1978) *Methods of flood estimation: a guide to the Flood Studies Report*, IH Report No.49, Institute of Hydrology, Wallingford (unpublished)
- UBA (1999) "WGK (wassergefährungsklassen). The German Water Hazard classes". *Regulatory Framework for substances hazardous to water*, Umwelt Bundesamt, Berlin.
Go to: www.umweltbundesamt.de/en/topics/chemicals/substances-hazardous-to-water/regulatory-framework
- UNITED NATIONS (2005) *The globally harmonized system of classification and labelling of chemicals (GHS)*, first revised edition, United Nations New York and Geneva (ISBN: 9-21116-927-5).
Go to: www.unece.org/fileadmin/DAM/trans/danger/publi/ghs/ghs_rev01/English/00e_intro.pdf
- US EPA (2013) "Secondary containment and impracticability", Chapter 4 SPCC *Guidance for regional inspectors*, United States Environmental Protection Agency, Washington DC, USA.
Go to: <http://tinyurl.com/kmeg2nh>
- WELSH ASSEMBLY GOVERNMENT (2010) *The Water Resources (Control of Pollution) (Silage, Slurry and Agricultural Fuel Oil) (Wales) Regulations 2010 "the SSAFO Wales Regulations". Guidance notes for farmers*, Welsh Assembly Government, Cardiff (ISBN: 978-0-75045-883-2). Go to: <http://tinyurl.com/omgmjzp>
- WILKINSON, A (1991) *Bund overtopping – the consequences following catastrophic failure of large volume liquid storage vessels*, UKAE Safety and Reliability Directorate, HSE, London (ISBN: 978-0-85356-358-7)
- WRC (2001) *Sewerage rehabilitation manual, fourth edition*, WRC, Swindon. Go to: <http://srm.wrcplc.co.uk/>
- WRC (2013) *Sewers for adoption, seventh edition*, Water Research Council, Swindon.
Go to: <http://tinyurl.com/nls2plq>
- WS ATKINS CONSULTANTS (2001) *Effects of secondary containment on source term modelling*, Contract Research Report (CRR) 324/2001, Health and Safety Executive, UK.
Go to: www.hse.gov.uk/research/crr_pdf/2001/crr01324.pdf

Statutes

Acts

- Flood and Water Management Act (FWMA) 2010 (No. 29)
- Pollution Prevention and Control Act 1999 (c. 24)
- Reservoirs Act 1975 (c. 23)
- Reservoirs (Scotland) Act 2011 (asp 9)

Directives

- Directive 96/82/EC of 9 December 1996 on the control of major-accident hazards involving dangerous substances
- Directive 2000/60/EC of the European Parliament and of the Council of 23 October 2000 establishing a framework for Community action in the field of water policy (Water Framework Directive)
- Directive 2003/105/EC of the European Parliament and of the Council of 16 December 2003 amending Council Directive 96/82/EC on the control of major-accident hazards involving dangerous substances (Seveso II)
- Directive 2008/1/EC of the European Parliament and of the Council of 15 January 2008 concerning integrated pollution prevention and control (codified version)
- Directive 2010/75/EU of the European Parliament and of the Council of 24 November 2010 on industrial emissions (integrated pollution prevention and control)

Directive 2012/18/EU of the European Parliament and of the Council of 4 July 2012 on the control of major-accident hazards involving dangerous substances, amending and subsequently repealing Council Directive 96/82/EC Text with EEA relevance (Sevesco III)

Regulations

- The Chemicals (Hazard Information and Packaging for Supply) Regulations 2009 (No. 716)
- The Control of Major Accident Hazards regulations (COMAH)
- The Construction (Design and Management) Regulations 1994 (No. 3140)
- The Construction (Design and Management) Regulations 2007 (No. 320)
- The Control of Pollution (Oil Storage) (England) Regulations (OSR) 2001 (No. 2954)
- The Control of Pollution (Silage, Slurry and Agricultural Fuel Oil) (Scotland) Regulations 2003 (No. 531)
- The Control of Pollution (Oil Storage) Regulations (Northern Ireland) 2010 (No. 412)
- The Environmental Permitting (England and Wales) Regulations 2010 (No. 675)
- The Plant Protection Products (Sustainable Use) Regulations 2012 (No. 1657)
- The Pollution Prevention and Control (England and Wales) Regulations 2000 (No. 1973)
- The Pollution Prevention and Control Regulations (Northern Ireland) 2003 (No. 46)
- The Pollution Prevention and Control (Scotland) Regulations 2012 (No. 360)
- REACH (Registration, Evaluation, Authorisation and Restriction of Chemicals) Regulations 2007
- Regulation (EC) No 1272/2008 of the European Parliament and of the Council of 16 December 2008 on classification, labelling and packaging of substances and mixtures, amending and repealing Directives 67/548/EEC and 1999/45/EC, and amending Regulation (EC) No 1907/2006
- Regulation (EU) No 305/2011 of the European Parliament and of the Council of 9 March 2011 laying down harmonised conditions for the marketing of construction products and repealing Council Directive 89/106/EEC
- The Reporting of Injuries, Diseases and Dangerous Occurrences (RIDDOR) Regulations 2013 (No. 1471)
- The Town and Country Planning (Environmental Impact Assessment) (England and Wales) Regulations 1999 (No. 293)
- The Town and Country Planning (Environmental Impact Assessment) Regulations 2011 (No. 1824)
- The Waste Management Licensing Regulations (Northern Ireland) 2003 (No. 493)
- The Water Environment (Water Framework Directive) (England and Wales) Regulations 2003 (No. 3242)
- The Water Environment (Oil Storage) (Scotland) Regulations 2006 (No. 133)
- The Water Resources (Control of Pollution) (Silage, Slurry and Agricultural Fuel Oil) (England) (Amendment) Regulations 2010 (No. 1091)
- Water Resources (Control of Pollution) (Silage, Slurry and Agricultural Fuel Oil) (England) (SSAFO) Regulations 2010 (SI 2010/639)
- Water Supply (Water Fixings) Regulations 1999 (No. 1148)

Standards

British

- BS 1564:1975 *Specification for pressed steel sectional rectangular tanks*
- BS 8301:1985 *Code of practice for building drainage*
- BS 8007:1987 *Code of practice for design of concrete structures for retaining aqueous liquids*

BS 1377-5:1990 *Methods of test for soils for civil engineering purposes Compressibility, permeability and durability tests*

BS 5306-2:1990 *Fire extinguishing installations and equipment on premises Specification for sprinkler systems*

BS 6399-2:1997 *Loading for buildings. Code of practice for wind loads (withdrawn)*

BS 8110-1:1997 *Structural use of concrete. Code of practice for design and construction*

BS 5930:1999+A2:2010 *Code of practice for site investigations*

BS 6213:2000+A1:2010 *Selection of construction sealants. Guide*

BS 5911-1:2002+A2:2010 *Concrete pipes and ancillary concrete products Specification for unreinforced and reinforced concrete pipes (including jacking pipes) and fittings with flexible joints (complementary to BS EN 1916:2002)*

BS 8500-1:2006+A1:2012 *Concrete. Complementary British Standard to BS EN 206-1. Method of specifying and guidance for the specifier*

BS 8500-2:2006+A1:2012 *Concrete. Complementary British Standard to BS EN 206-1. Specification for constituent materials and concrete*

BS 5502-22:2003+A1:2013 *Buildings and structures for agriculture Code of practice for design, construction and loading*

BS 6031:2009 *Code of practice for earthworks*

BS 476-10:2009 *Fire tests on building materials and structures Guide to the principles, selection, role and application of fire testing and their outputs*

BS 5502-50:1993+A2:2010 *Buildings and structures for agriculture. Code of practice for design, construction and use of storage tanks and reception pits for livestock slurry*

BS 799-5:2010 *Oil burning equipment. Carbon steel oil storage tanks. Specification*

BS 8550:2010 *Guide for the auditing of water quality sampling*

BS EN 295-1:2013 *Vitrified clay pipe systems for drains and sewers. Requirements for pipes, fittings and joints*

BS EN 598:2007+A1:2009 *Ductile iron pipes, fittings, accessories and their joints for sewerage applications – requirements and test methods*

BS EN 642:1995 *Prestressed concrete pressure pipes, cylinder and non-cylinder, including joints, fittings and specific requirement for prestressing steel for pipes*

BS EN 1610:1998 *Construction and testing of drains and sewers*

BS EN 1452-1:1999 *Plastics piping systems for water supply. Unplasticized poly (vinyl chloride) (PVC-U) General*

BS EN 805:2000 *Water supply. Requirements for systems and components outside buildings*

BS EN 206-1:2000 *Concrete specification, performance, production and conformity*

BS EN 13121-2:2003 *GRP tanks and vessels for use above ground composite materials. Chemical resistance*

BS EN 1504-10:2003 *Products and systems for the protection and repair of concrete structures. Definitions. Requirements. Quality control and evaluation of conformity. Site application of products and systems and quality control of the works*

BS EN 1504-2:2004 *Products and systems for the protection and repair of concrete structures. Definitions, requirements, quality control and evaluation of conformity. Surface protection systems for concrete*

BS EN 1992-1-1:2004 *Eurocode 2: Design of concrete structures. General rules and rules for buildings*

BS EN 1992-1-1:2004 *Eurocode 2: Design of concrete structures. General rules and rules for buildings*

BS EN 1997-1:2004 *Eurocode 7. Geotechnical design. General rules*

BS EN 1504-4:2004 *Products and systems for the protection and repair of concrete structures. Definitions, requirements, quality control and evaluation of conformity. Structural bonding*

BS EN 14015:2004 *Specification for the design and manufacture of site built, vertical, cylindrical, flat-bottomed, above ground, welded, steel tanks for the storage of liquids at ambient temperature and above*

BS EN 1504-3:2005 *Products and systems for the protection and repair of concrete structures. Definitions, requirements, quality control and evaluation of conformity. Structural and non-structural repair*

BS EN 1991-1-4:2005+A1:2020 *Eurocode 1. Actions on structures. General actions*

BS EN 1997-2:2007 *Eurocode 7. Geotechnical design. Ground investigation and testing*

BS EN 752:2008 *Drain and sewer systems outside buildings*

BS EN 1996-1-1:2005+A1:2012 *Eurocode 6: Design of masonry structures. General rules for reinforced and unreinforced masonry structures*

BS EN 1504-6:2006 *Products and systems for the protection and repair of concrete structures. Definitions, requirements, quality control and evaluation of conformity. Anchoring of reinforcing steel bar*

BS EN 1992-3:2006 *Design of concrete structures. Liquid retaining and containing structures*

NA to BS EN 1992-3:2006:2007 *UK National Annex to Eurocode 2. Design of concrete structures. Liquid retaining and containing structures*

BS EN 12845:2004+A2:2009 *Fixed firefighting systems. Automatic sprinkler systems. Design, installation and maintenance*

BS EN 598:2007+A1:2009 *Ductile iron pipes, fittings, accessories and their joints for sewerage applications. Requirements and test methods*

BS EN 1504-9:2008 *Products and systems for the protection and repair of concrete structures- Definitions, requirements, quality control and evaluation of conformity General principles for use of products and systems*

BS EN 13121-3:2008+A1:2010 *GRP tanks and vessels for use above ground. Design and workmanship*

BS EN 1504-5:2013 *Products and systems for the protection and repair of concrete structures. Definitions, requirements, quality control and evaluation of conformity Concrete injection*

BS EN ISO 9001:2008 *Quality management systems. Requirements*

BS EN ISO 11600:2003+A1:2011 *Building construction. Jointing products. Classification and requirements for sealants*

CP 110-1:1972 *Code of practice for the structural use of concrete Design, materials and workmanship* (superseded)

International

ISO/TR 26368:2012 *Environmental damage limitation from fire-fighting water runoff*

ISO 2531:2009 *Ductile iron pipes, fittings, accessories and their joints for water applications*

ISO 8179-1:2004 *Ductile iron pipes – external zinc-based coating. Part 1: Metallic zinc with finishing layer*

Useful websites

Environment and Countryside: <https://www.gov.uk/browse/environment-countryside>

European Centre for Toxicology and Ecotoxicology of Chemicals: www.ecetoc.org/publications

HSE 'ALARP' At a glance: www.hse.gov.uk/risk/theory/alarplance.htm

Appendices

A1 Summary of UK and European legislation and international guidance relevant to containment

It should be noted that the information presented in Tables A1.1 and A1.2 is not exhaustive. This high level summary presents the key regulations and guidance available at the time of publishing this guide and is intended to help the reader navigate to the most relevant regulatory instruments.

Table A1.1 UK and European legislation relevant to containment

Statutory Instrument	Detail	Description	Link
Council Directive 96/82/EC Directive 2003/105/EC (The Seveso II Directive)	Control of Major Accident and Hazards (COMAH) Regulations 1994 as amended	Places a duty on duty holders to ensure that major hazards have been addressed and all practicable steps have been taken to limit the probability and consequences of major accident hazards. Requires COMAH designated facilities to take all measures necessary with regard to the containment of hazardous liquids. * at the time of writing these Regulations are currently being updated to implement the Seveso III Directive (which will be implemented by 2015).	www.hse.gov.uk/comah/index.htm
Classification, labelling and packaging of substances and mixtures regulations	Regulation (EC) No 1272/2008	There are new scientific criteria used to assess the hazardous properties of chemicals including environmental hazards. This allows users to identify the environmental hazards specific to each material. * these Regulations will be fully enforced on 1 June 2015. This regulation is related to The Chemicals (Hazard Information and Packaging for Supply) Regulations 2009 and the European REACH Regulations 2007, which detail the requirements for material safety data sheets.	ec.europa.eu/enterprise/sectors/chemicals/classification/index_en.htm
The Environmental Permitting (England and Wales) Regulations 2010 The Pollution Prevention and Control (Scotland) Regulations 2012		This statutory instrument implements the IED Directive 2010/75/EU, which replaced a number of EU directives including Directive 2008/1/EC in January 2013. They are the principle regulations under which the process industry including power, oil refineries, iron and steel, metal finishing, chemical production, waste food and drink, farming, water abstraction and discharges etc are regulated. It covers all storage systems associated with these industries. It requires operations within its scope to obtain an Environmental Permit, under which the operation is regulated. One of the regulations requirements is that operators use BAT to prevent or minimise pollution from the operation of the installation, such that significant pollution will not be caused. The EU produces guidance on what represents BAT in a series of BREF notes, which are reviewed periodically. As well as sector BREF notes, there is a BREF note on emissions from storage commonly referred to as the Storage BREF Note (European Commission, 2006), which is currently scheduled to be reviewed in 2018.	www.environment-agency.gov.uk/business/topics/permitting/32320.aspx
Pollution Prevention Act Control Act 1999	Directive 2010/75/ EU (integrated pollution prevention and control)	The Pollution Prevention and Control Act 1999 is an enabling Act of Parliament under which regulations and Statutory Instruments controlling pollution can be made. The Environmental Permitting Regulations 2010 were made under this act.	www.environmentagency.gov.uk/business/regulation/109813.aspx
Pollution Prevention and Control (Scotland) (PPC) Regulations 2012		PPC 2012 permit and regulate many industrial activities that may pollute our environment. It came into force on 7 January 2013. These Regulations implement the requirements of Directive 2010/75/EU.	www.sepa.org.uk/air/process_industry_regulation/pollution_prevention__control.aspx
The Control of Pollution (Oil Storage) (England) Regulations 2001		These Regulations require anyone in England who stores more than 200 litres of oil, to provide more secure containment facilities for tanks, drums, intermediate bulk containers (IBCs) and mobile bowisers. This is to prevent oil escaping into the environment.	http://webarchive.nationalarchives.gov.uk/20140328084622/http://www.environment-agency.gov.uk/business/topics/oil/default.aspx

Table A1.1 UK and European legislation relevant to containment (contd)

<p>The Control of Pollution (Oil Storage) Regulations (Northern Ireland) 2010</p>		<p>The Regulations apply to above ground oil storage facilities on industrial, commercial and institutional residential sites. They also extend to companies who refine or distribute oil. The Regulations set minimum design standards for new and existing above ground oil storage facilities, codifying existing good practice to ensure that above ground oil storage facilities are adequately constructed. A key requirement of the Regulations is for the storage container to have a secondary containment system to ensure that any leaking or spilt oil is contained and does not enter the aquatic environment.</p>	<p>www.doeni.gov.uk/index/protect_the_environment/water/oil_storage.htm</p>
<p>The Water Environment (Oil Storage) (Scotland) Regulations 2006</p>		<p>The regulations apply to both new and existing oil storage tanks. The regulations set design standards for above-ground oil storage facilities: Where oil is stored in any portable container with a storage capacity of less than 200 litres, the container must be of sufficient strength and structural integrity to ensure that it is unlikely to burst or leak in its ordinary use. Where the container has a storage capacity of 200 litres or more, the regulations require provision of a secondary containment (a bund or drip-tray) to ensure that any leaking or spilt oil cannot enter the water environment.</p>	<p>www.sepa.org.uk/water/water_regulation/regimes/pollution_control/oil_storage.aspx</p>
<p>The Water Resources (Control of Pollution) (Silage, Slurry and Agricultural Fuel Oil) (England) (Amendment) Regulations 2010 (No. 1094)</p>		<p>These Regulations aim to prevent water pollution from stores of silage, slurry and agricultural fuel oil. They set out requirements for the design construction and maintenance of new, substantially reconstructed or substantially enlarged facilities for storing these substances. The regulations detailed the requirement that storage facilities should be sited at least 10 m from inland freshwater or coastal water and have a 20 year life expectancy. Guidance on how to comply with the Regulations is available from Defra (2010) and Welsh Assembly Government (2010).</p>	<p>www.environment-agency.gov.uk/business/sectors/118798.aspx</p>
<p>The Control of Pollution (Silage, Slurry and Agricultural Fuel Oil) (Scotland) Regulations 2003</p>		<p>The regulations require that suitably sited, designed and constructed facilities are put in place to collect, store and manage manures and slurries. They also set minimum standards for new, substantially reconstructed, or enlarged structures, such as silos and slurry stores and the consideration of secondary containment measures.</p>	<p>www.sepa.org.uk/land/agriculture/agricultural_regulation.aspx</p>
<p>The Plant Protection Products (Sustainable Use) Regulations 2012</p>		<p>Set out the regulations in relation to the use of pesticides and insecticides that are plant protection products and includes guidance on use and storage of plant protection products.</p>	<p>www.plantprotection.info/UKPGOnline/Home.aspx</p>
<p>Waste Management Licencing (Northern Ireland) 2003</p>		<p>The waste regulation authorities issue licences for waste treatment, storage and disposal activities which generally include conditions on the storage of waste materials.</p>	<p>www.doeni.gov.uk/niea/waste-home/authorisation/license.htm</p>
<p>Contaminated Land (England) Regulations (2012)</p>		<p>The objectives of these Regulations are to provide an improved system for the identification and remediation of land where contamination is causing unacceptable risks to health or the environment. Such risks are to be assessed in the context of the current use and circumstances of the land in accordance with the Government's "suitable for use" approach. In the context of this document the regime is likely to focus on the assessment and remediation of sites where contamination may have entered soils as a result of containment failures.</p>	<p>www.defra.gov.uk/environment/quality/land</p>

Table A.1.1 UK and European legislation relevant to containment (contd)

<p>The Town & Country Planning Act (Assessment of Environmental Effects) Regulations 1999</p>	<p>(51/1988/1199)</p>	<p>These Regulations were developed in response to a European Directive requiring an assessment of the impact on the environment of projects likely to have significant effects. It applies to all planning applications for an EIA development as defined by the act. The act prohibits the granting of planning permission without first considering the status of the environmental information supplied. The EIA has become a vital tool used by local authorities to determine planning consent and permission. Note that for new installations or 'changes' to existing premises requires the assessment of materials on the environment and the identification whether control measures such as containment systems are required to minimise the potential impact on the environment.</p>	<p>www.legislation.gov.uk/ukxi/2011/1824/introduction/made</p>
---	-----------------------	--	---

Table A1.2 International guidance and publications relevant to containment

Author	Title	Description	Link
EA, SEPA, EHS (2013b)	How to comply with your environmental permit	Describes the standards and measures required to control the most common risks of pollution from various activities and how to comply with the conditions of environmental permits.	www.environment-agency.gov.uk/business/topics/permitting/32320.aspx
CA (2008a)	COMAH Competent Authority policy on containment of bulk hazardous liquids at COMAH establishments. The Control of Major Accident Hazards (COMAH) Regulations 1999	Primary regulatory policy statement on containment systems for COMAH sites	http://tinyurl.com/ncvclon
CA (2008b)	Supporting guidance for secondary and tertiary containment	Primary competent authority guidance. Establishes requirement for primary, secondary and tertiary containment.	http://tinyurl.com/perms60
CA (2008c)	Containment of bulk hazardous liquids at COMAH establishments. Containment policy. Supporting guidance for secondary and tertiary containment and implementation principles for regulators	Primary regulatory guidance on containment design for bulk storage at COMAH sites. Detailed guidance on the implementation for regulators.	http://tinyurl.com/p3eu4as
HSE, EA, SEPA (2010)	COMAH Competent Authority Workstream. Secondary and Tertiary Containment of Bulk Hazardous Liquids at COMAH Establishments	Guidance on secondary and tertiary containment for all Bunccefield 'in-scope' gasoline tanks, and tanks storing petroleum products.	www.hse.gov.uk/comah/guidance/bulk-hazardous-liquids.pdf
CA (in press)	"All measures necessary" – environmental aspects (guidance for competent authority inspectors and operators)	Guidance for CA inspectors and site operators on all measures necessary (AMN) relating to prevent and mitigation of environmental aspects of major accidents.	www.hse.gov.uk/comah
WS Atkins Consultants (2001)	Effects of secondary containment on source term modelling	Provides technical analysis on the effectiveness of secondary containment measures used within major hazard sites.	www.hse.gov.uk/research/crr_pdf/2001/crr01324.pdf
Wilkinson (1991)	Bund overtopping – the consequences following catastrophic failure of large volume liquid storage vessels	The emphasis of the study is on safety rather than pollution control. The findings indicate that pressures behind bund walls can peak at up to six times normal hydrostatic pressure in certain circumstances. Advice is given on bund size and geometry to minimise the risk of failure by spigot flow, 'sloshing' or overtopping.	
Cronin and Evans (2002)	A series of experiments to study the spreading of liquid pools with different bund arrangements	58 experiments were conducted to study the flow of water released from a slit at the base of a tank into a bund.	www.hse.gov.uk/research/crr_pdf/2002/crr02405.pdf
Atherton (2005)	An experimental investigation of bund wall overtopping and dynamic pressures on the bund wall following catastrophic failure of a storage vessel	Describes analysis for the surges that may occur following a catastrophic failure of a tank (and therefore overflow the bund).	www.hse.gov.uk/research/rpdf/r333.pdf

Table A1.2 International guidance and publications relevant to containment (contd)

<p>HSE (2009)</p>	<p>Safety and environmental standards for fuel storage sites, Process Safety Leadership Group (PSLG), Final report</p>	<p>Specification of minimum standards of control which should be in place at all sites storing large volumes of gasoline. Document supersedes and replaces the following series of documents produced following the Buncefield incident:</p> <ul style="list-style-type: none"> ■ BSTG (2006) Initial Report to the Health and Safety Commission and the Environment Agency of the investigation into the explosions and fires at the Buncefield oil storage and transfer depot, Hemel Hempstead, on 11 December 2005 ■ BSTG (2007) Safety and environmental standards for fuel storage sites, Buncefield Standards Task Group (BSTG) Final Report ■ BSTG (2008a) The Buncefield Incident 11 December 2005: The final report of the Major Incident Investigation Board. Volume 1 ■ BSTG (2008b) The Buncefield Incident 11 December 2005: The final report of the Major Incident Investigation Board. Volume 2 ■ BSTG (2008c) Recommendations on the emergency preparedness for, response to and recovery from incident 	<p>www.buncefieldinvestigation.gov.uk/reports/index.htm</p>
<p>EI (2009)</p>	<p>Environmental risk assessment of bulk liquid storage facilities: a screening tool</p>	<p>Simple tool to assess the risk to the environment of an unplanned release of liquids from above ground storage tanks.</p>	<p>www.energypublishing.org</p>
<p>EA, NIEA, SEPA (2011a)</p>	<p>PPG2 Above ground oil storage tanks</p>	<p>General advice on the siting and maintenance of above ground tanks with particular reference to compliance with the Control of Pollution (Oil Storage Regulations) England, the Control of Pollution (Oil Storage Regulations (Northern Ireland), and the Water Environment (Oil Storage (Scotland) Regulations.</p>	<p>http://tinyurl.com/qgdrxo8</p>
<p>EA, NIEA, SEPA (2000)</p>	<p>PPG18 Managing fire water and major spillages</p>	<p>Identifies the equipment and techniques available to prevent damage to the water environment caused by fires and major spillages. The need for a risk assessment of the environmental hazards is emphasised and factors the types of containment discussed. The guidance also includes containment systems and methods that can be used for damage mitigation including:</p> <ul style="list-style-type: none"> ■ containment systems (primary, secondary and emergency) ■ emergency material and equipment ■ management and strategies. 	<p>http://tinyurl.com/nugbzip9</p>
<p>EA, NIEA, SEPA (2011b)</p>	<p>PPG22 Dealing with spills</p>	<p>Provides information to prevent and mitigate pollution for any environmentally hazardous materials that are stored and transported.</p>	<p>http://tinyurl.com/nnhx25c</p>

Table A1.2 International guidance and publications relevant to containment (contd)

EA, NIEA, SEPA (2007)	PPG28 Controlled burn	Instructions to help decide whether controlled burn should be used as part of a fire fighting strategy to prevent or reduce damage to the environment. Presents additional risk assessment options and consideration of containment.	http://tinyurl.com/nugpzb9
EI (2013)	Guidance on risk assessment and design of tertiary containment systems for bulk storage of petroleum, petroleum products, or other fuels	The guidance provides clarification on the requirements for tertiary containment systems and to enable operating companies to assess the need for, and conceptual design of, such systems, as part of the site's overall containment strategy. The document has sought to provide further guidance to that currently available from the EA, SEPA and HSE.	www.energyinst.org/home
EI (2012)	Model code of safe practice. Part 19: Fire precautions at petroleum refineries and bulk storage installations	Is concerned with fire precautions for bulk storage installations. It also contains guidance on the calculation of fire water quantities for design for fire event scenarios. It provides information on fire hazard management to meet the European Seveso III Directive.	www.energypublishing.org
EI (2013a)	Model code of safe practice. Part 2: Design, construction and operation of petroleum distribution installations	Provides recommendations on the layout and design of petroleum products installations and depots (including bunds).	www.energypublishing.org
EI (2007)	Environmental guidelines for petroleum distribution installations	Details updated good practice on the protection of land and groundwater, in particular emphasising risk assessment as the key tool in environmental management.	www.energypublishing.org
EI (2014b)	Guidance on conceptual design, selection and life cycle assurance of liners intended to improve integrity of bunds to above-ground storage tanks for bulk storage of petroleum, petroleum products or other fuels	Provides guidance on selection, installation and ongoing assurance of product options like under-tank liners and leak detection systems that are used to provide additional integrity underneath above-ground storage tanks. Includes guidance on evaluation of containment integrity performance (during both installation and operation).	www.energypublishing.org
Defra (2011)	Green Leaves III. Guidelines for environmental risk assessment and management	The document provides generic guidelines for the assessment and management of environmental risks.	http://tinyurl.com/q/33kp8t
Hanlon and McGlashan (2008)	Fire and Rescue Service Manual volume 2. Fire service operations – environmental protection	Describes operational practices used by the Fire and Rescue Service during an incident to mitigate environmental impacts.	http://tinyurl.com/qdfqnmk
Defra (1998)	Code of Practice for suppliers of pesticides to agriculture, horticulture and forestry (Yellow Code)	Guidance for those involved commercially in the sale, supply and storage for sale of pesticides approved for agricultural use.	http://tinyurl.com/kdjegq6
HSE (1998b)	The storage of flammable liquids in tanks	HSE good practice. Document supersedes both HSG50 and HSG52 (storage of flammable liquids in fixed tanks exceeding 10 000 m ³ total capacity).	www.hse.gov.uk/pubns/books/hsg176.htm
HSE (1999)	Emergency planning for major accidents	Practical guidance on the preparation of emergency response plans.	www.hse.gov.uk/pubns/priced/hsg191.pdf

Table A1.2 International guidance and publications relevant to containment (contd)

HSE (1996)	Safe use and handling of flammable liquids	Guidance for site operators using flammable liquids in general work activities. Emphasis on risks of fire and explosion.	www.hse.gov.uk/pubns/books/hsg140.htm
HSE (2009b)	Chemical warehousing, the storage of packaged dangerous substances	Recommends bunds are used as secondary containment.	www.hse.gov.uk/pubns/books/hsg71.htm
HSE (1998a)	The storage of flammable liquids in containers	The guidance is concerned with the size and layout of bunds rather than the detailed construction.	www.hse.gov.uk/pubns/books/hsg51.htm
CA (1999)	Guidance on the environmental risk assessment aspects of COMAH safety reports	Includes general guidance on environmental risk assessment relevant to major accident scenarios.	http://www.hse.gov.uk/comah/guidance/sram.pdf
HSE (2007a)	Technical Measures Document. Secondary containment	Describes the principles and types of secondary containment system available.	www.hse.gov.uk/comah/sragtech/techmeascontain.htm
HSE (2007b)	Technical Measures Document. Emergency response/spill control	Information on emergency response and spill control measures that can be adopted in plant operation to ensure safe operation.	www.hse.gov.uk/comah/sragtech/techmeasspill.htm
EPA (1995)	Fire-water retention facilities. (Draft) Guidance note to industry on the requirements for fire-water retention facilities	Provides guidance to operators of industrial activities on the requirements for, design and types of, firewater retention facilities.	www.epa.ie/pubs/advice/licence/Draft%20firewater%20retention.pdf
US EPA (2013)	Secondary containment and impracticability determinations	Presents general and specific provisions to address the potential for oil discharges from all parts of a facility.	http://tinyurl.com/kmeg2nh
Queensland Government (2007)	Narangba Industrial Estate: Multi-agency fire and firewater risk minimisation inspection program	Report written in relation to the Narangba Industrial Estate, within which are located 17 high impact industries, storing hazardous materials.	www.emergency.qld.gov.au/publications/pdf/inter_agency_report.pdf
WRC (2012)	Sewers for Adoption, seventh edition	Useful information for the design of small sewerage systems.	http://sfa.wrcplc.co.uk
European Centre for Toxicology and Ecotoxicology of Chemicals	Various guidance and publications	Provides environmental hazard assessments for substances on the basis of ecotoxicology and toxicology.	www.ecetoc.org/Publications/
Gangolli (1999)	Dictionary of Substances and their Effects (DOSE), second edition	A comprehensive reference manual providing physico-chemical and ecotoxicity data on some 6000 substances. The substances are selected from lists, including The EC Classification Packaging and Labelling Regulations, The EC 'Black' and 'Grey' substances, the UK DOE 'Red' list and the USA and Canada Priority Pollutants List	www.rsc.org/Publishing/CurrentAwareness/DOSE/index.asp

A2 List of hazardous substances

Lists of hazardous substances are available from many sources, including UK and EC legislation, international conventions, national priority pollutants from non-EC countries etc. The source documents generally aim to protect surface or groundwater, fish or shellfish, or water for human consumption.

Other legislation has generated lists of hazardous chemicals; for example, the CIMAH regulations or the classification, packaging and labelling regulations. Their prime aim may be health and safety, consumer protection, or transportation rather than environmental protection. It is beyond the scope of this report to comment upon them.

Although all substances which are hazardous in the aquatic environment must be fully considered in any risk assessment procedure, it is likely that the statutory authorities will be particularly interested in measures to reduce the likelihood of spills of the most dangerous materials. It is generally agreed that the most dangerous substances are those on the Water Framework Directive (WFD) Priority substances list. The WFD priority substances list is given in Box A2.1. Annex VIII of the WFD also gives an indicative list of the main pollutants, which is given in Box A2.2.

Box A2.1 WFD priority substances

- | | |
|--|--|
| ■ Alachlor. | ■ Lead and its compounds. |
| ■ Anthracene. | ■ Mercury and its compounds. |
| ■ Atrazine. | ■ Naphthalene. |
| ■ Benzene. | ■ Nickel and its compounds. |
| ■ Brominated diphenyletheriv. | ■ Nonylphenols. |
| ■ Pentabromodiphenylether (congener numbers 28, 47, 99, 100, 153 and 154). | ■ (4-nonylphenol). |
| ■ Cadmium and its compounds. | ■ Octylphenols. |
| ■ Chloroalkanes, C10-13 iv. | ■ (4-(1,1',3,3'-tetramethylbutyl)-phenol). |
| ■ Chlorfenvinphos. | ■ Pentachlorobenzene. |
| ■ Chlorpyrifos. | ■ Pentachlorophenol. |
| ■ (Chlorpyrifos-ethyl). | ■ Polyaromatic hydrocarbons. |
| ■ 1,2-Dichloroethane. | ■ (Benzo(a)pyrene). |
| ■ Dichloromethane. | ■ (Benzo(b)fluoranthene). |
| ■ Di(2-ethylhexyl)phthalate (DEHP). | ■ (Benzo(g,h,i)perylene). |
| ■ Diuron. | ■ (Benzo(k)fluoranthene). |
| ■ Endosulfan. | ■ (Indeno(1,2,3-cd)pyrene). |
| ■ Fluoranthenevi. | ■ Simazine. |
| ■ Hexachlorobenzene. | ■ Tributyltin compounds. |
| ■ Hexachlorobutadiene. | ■ (Tributyltin-cation). |
| ■ Hexachlorocyclohexane. | ■ Trichlorobenzenes. |
| ■ Isoproturon. | ■ Trichloromethane (chloroform). |
| | ■ Trifluralin. |

Box A2.2 *Indicative list of the main pollutants*

- | | |
|--|---|
| <ul style="list-style-type: none">■ Organohalogen compounds and substances that may form such compounds in the aquatic environment.■ Organophosphorous compounds.■ Organotin compounds.■ Substances and preparations, or the breakdown products of such, which have been proved to possess carcinogenic or mutagenic properties or properties which may affect steroidogenic, thyroid, reproduction or other endocrine-related functions in or via the aquatic environment.■ Persistent hydrocarbons and persistent and bioaccumulable organic toxic substances. | <ul style="list-style-type: none">■ cyanides.■ metals and their compounds.■ arsenic and its compounds.■ biocides and plant protection products.■ materials in suspension.■ substances which contribute to eutrophication (in particular, nitrates and phosphates).■ substances that have an unfavourable influence on the oxygen balance (and can be measured using parameters such as BOD, COD). |
|--|---|

Other lists of substances or generic groups of substances are contained in:

- List I (Black List) and List II (Grey List) of the EC Directive 76/464.
- List I and List II of the Oslo and Paris Conventions.
- List I and List II of the Groundwater Directive.
- EC priority candidate list.
- First priority candidate red list.
- North Sea Conference list of banned or restricted pesticides.
- North Sea Conference of priority hazardous substances.
- North Sea Conference reference list of substances.
- Schedule 5 of SI 1991 No 472 (prescribed substances to water).

Edwards (1992) contains lists of the specific substances from the above sources. IMO (2014) has published a list of maritime pollutants, and the German water hazard class system (WGK) is an equivalent listing (UBA, 1999), and as already mentioned, many other lists of dangerous chemicals have been produced for a variety of purposes.

Most of the substances in the lists in Box A2.1 and A2.2 were selected on the basis of specific selection criteria. The most commonly used criteria are:

- toxicity
- persistence
- bioaccumulation
- carcinogenicity (although mutagenicity and teratogenicity are also important).

Boxes A2.1 and A2.2 indicate those substances that have long-term widespread effects in water and target organisms including man, eg heavy metal and chlorinated hydrocarbons, or short-term acute effects, such as highly toxic and biologically active pesticides. They do not include the very wide range of materials, which are likely to have equally severe effects at least in the short-term and in the vicinity of the discharge point. An indication of the broad classes that these materials fall into is given in Box A2.3.

Box A2.3 *Broad classes of materials with the potential to pollute water*

- | | |
|---|--|
| <ul style="list-style-type: none">■ acids and alkalis■ oxidising and reducing agents■ corrosive materials■ inert solids■ other inorganic materials (ammonia, chlorine, sulphide, metal salts)■ dyes, colours, pigments | <ul style="list-style-type: none">■ detergents■ organic solvents■ oils, fuels, fats and waxes■ other organic compounds (including foodstuffs)■ microbial contamination (e.coli, faecal streptococci, coliforms). |
|---|--|

A3 Undertank leak detection systems

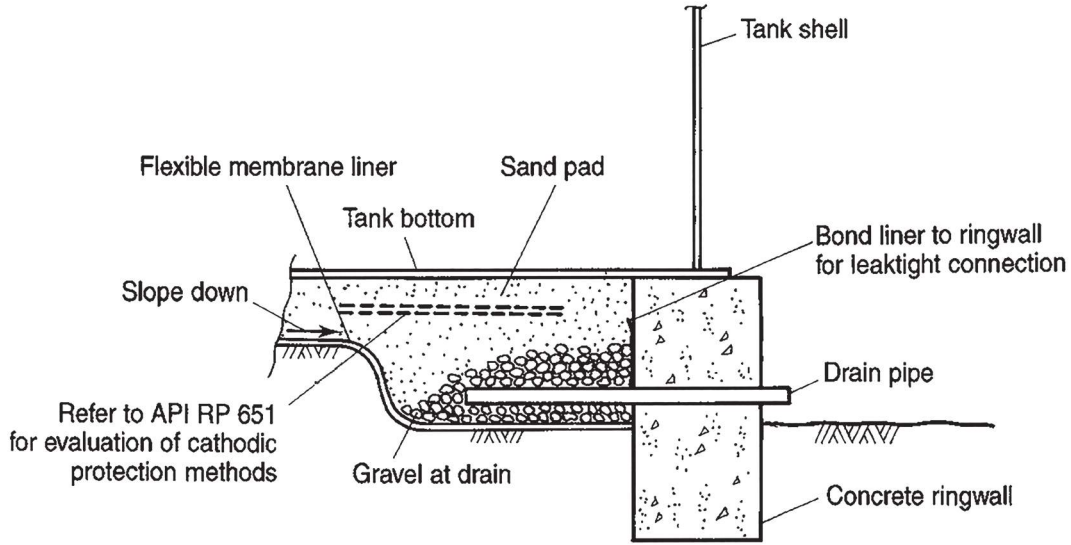

Figure A3.1 Concrete ringwall with undertank leak detection at the tank perimeter (from API, 2005)

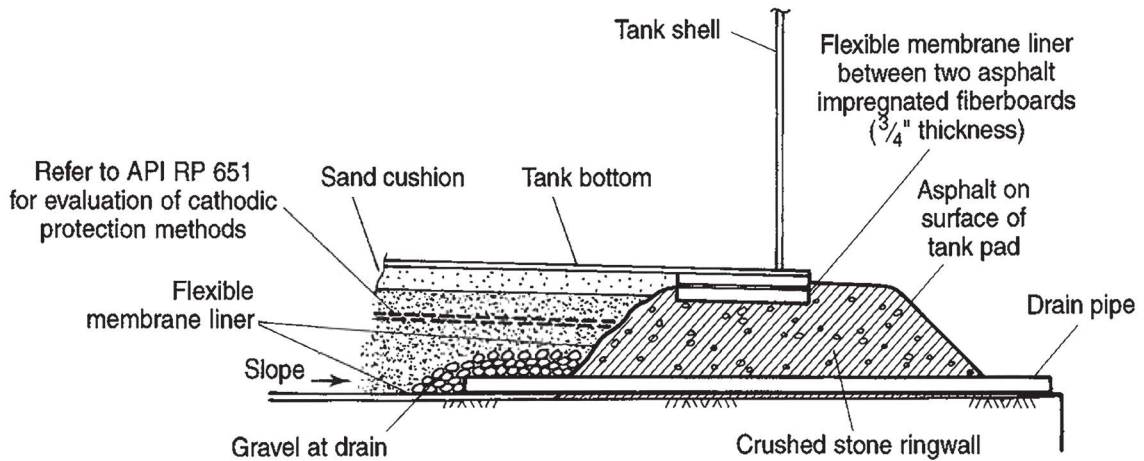

Figure A3.2 Crushed stone ringwall with undertank leak detection at the tank perimeter (from API, 2005)

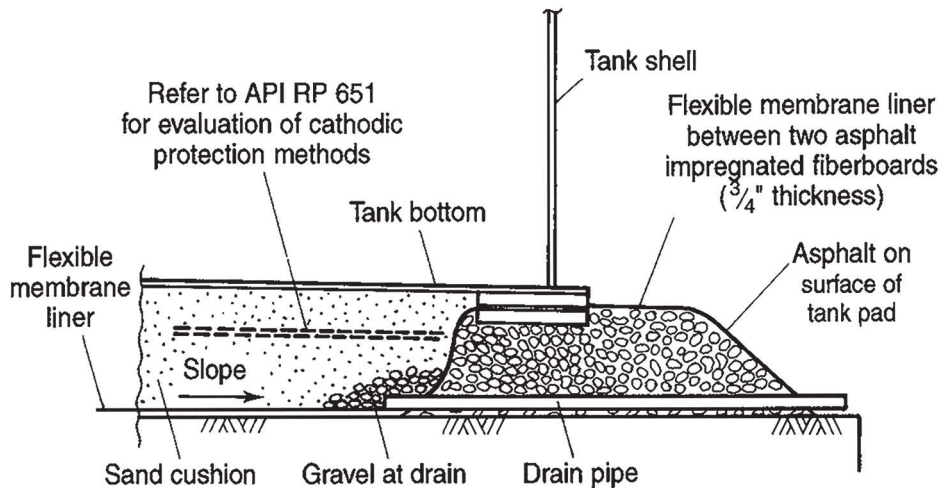

Figure A3.3 Earthen foundation with undertank leak detection at the tank perimeter (from API, 2005)

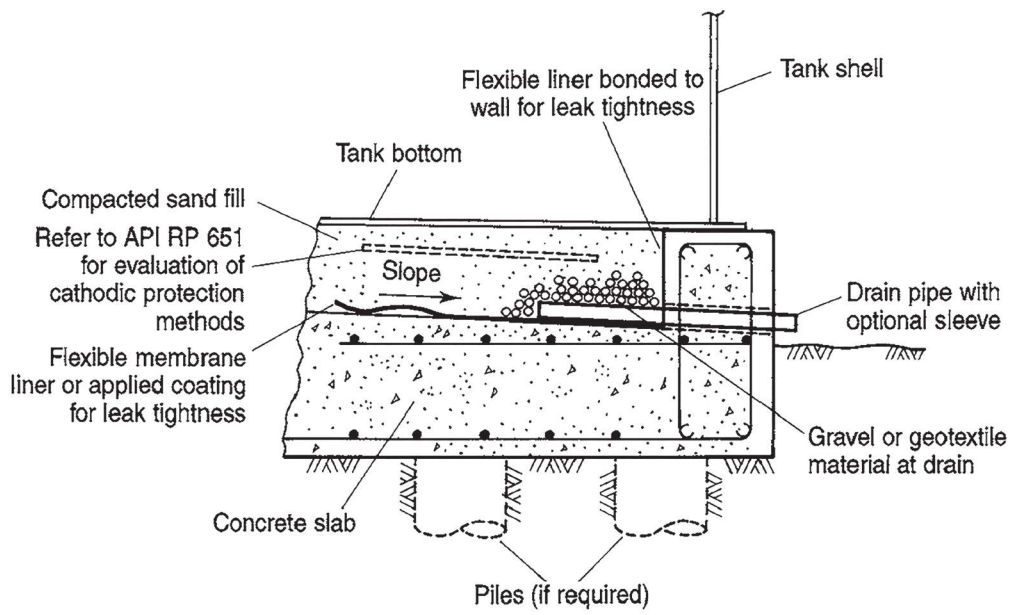

Figure A3.4 Reinforced concrete slab with undertank leak detection at the perimeter (from API, 2005)

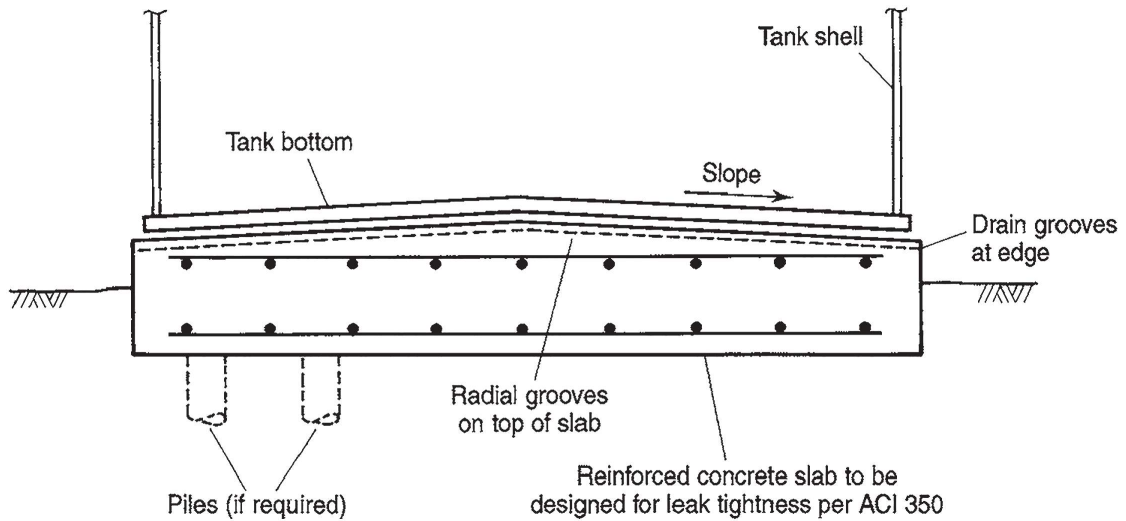

Figure A3.5 Reinforced concrete slab with radial grooves for leak detection (from API, 2005)

A4 Surface protection systems for concrete

Figure A4.1 and Table A4.1 are taken from BS EN 1504-9:2008.

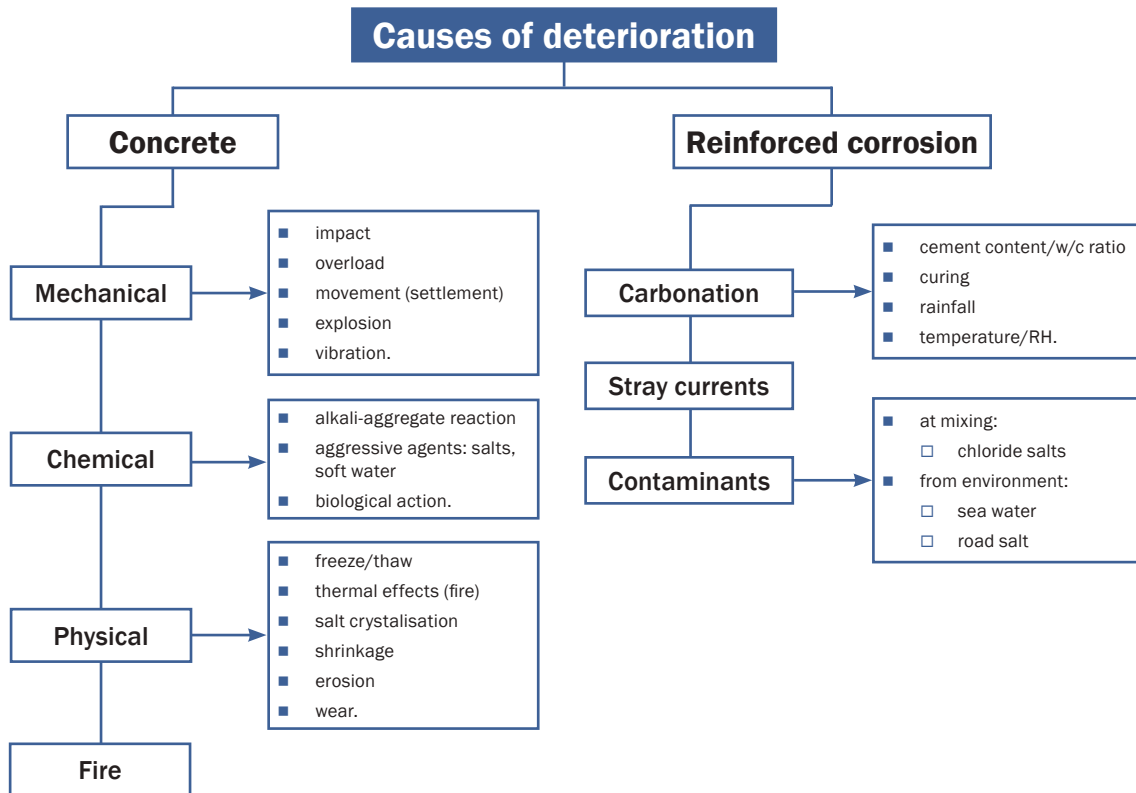

Figure A4.1 Common deterioration processes that affect concrete and reinforced concrete structures (after BS EN 1504-9:2008)

Table A4.1 Principles and methods for protection and repair of concrete structures

Principle	Examples of methods based on the principles	Relevant part of BS EN 1504 (where applicable)
Principles and methods related to defects in concrete		
1 Protection against ingress	1.1 Hydrophobic impregnation	2
	1.2 Impregnation	2
	1.3 Coating	2
	1.4 Surface bandaging of cracks	
	1.5 Filing of cracks	5
	1.6 Transferring cracks into joints	
	1.7 Erecting external panels*	
	1.8 Applying membranes*	

Table A4.1 Principles and methods for protection and repair of concrete structures (contd)

2 Moisture control	2.1 Hydrophobic impregnation	2
	2.2 Impregnation	2
	2.3 Coating	2
	2.4 Erecting external panels	
	2.5 Electrochemical treatment	
3 Concrete restoration	3.1 Hand applied mortar	3
	3.2 Recasting with concrete or mortar	3
	3.3 Spraying concrete or mortar	3
	3.4 Replacing elements	
4 Structural strengthening	4.1 Adding or replacing embedded or external reinforcing bars	
	4.2 Adding reinforcement anchored in pre-formed or drilled holes	6
	4.3 Bonding plate reinforcement	4
	4.4 Adding mortar or concrete	3, 4
	4.5 Injecting cracks, void or interstices	5
	4.6 Filling cracks, voids or interstices	5
	4.7 Prestressing (post tensioning)	
5 Increasing physical resistance	5.1 Coating	2
	5.2 Impregnation	2
	5.3 Adding mortar or concrete	3
6 Resistance to chemicals	6.1 Coating	2
	6.2 Impregnation	2
	6.3 Adding mortar or concrete	3
Principles and methods related to reinforcement corrosion		
7 Preserving or restoring passivity	7.1 Increasing cover with additional mortar or concrete	3
	7.2 Replacing contaminated or carbonated concrete	3
	7.3 Electrochemical realkalisation of carbonated concrete	
	7.4 Realkalisation of carbonated concrete by diffusion	
	7.5 Electrochemical chloride extraction	
8 Increasing resistivity	8.1 Hydrophobic impregnation	2
	8.2 Impregnation	2
	8.3 Coating	2
9 Cathodic control	9.1 Limiting oxygen content (at the cathode) by saturation or surface coating	
10 Cathodic protection	10.1 Applying an electrical potential	
11 Control of anodic areas	11.1 Active coating of the reinforcement	7
	11.2 Barrier coating of the reinforcement	7
	11.3 Applying corrosion inhibitors in or to the concrete	

Note

* These methods may also be applicable to other principles.

A5 Expansion and contraction joints

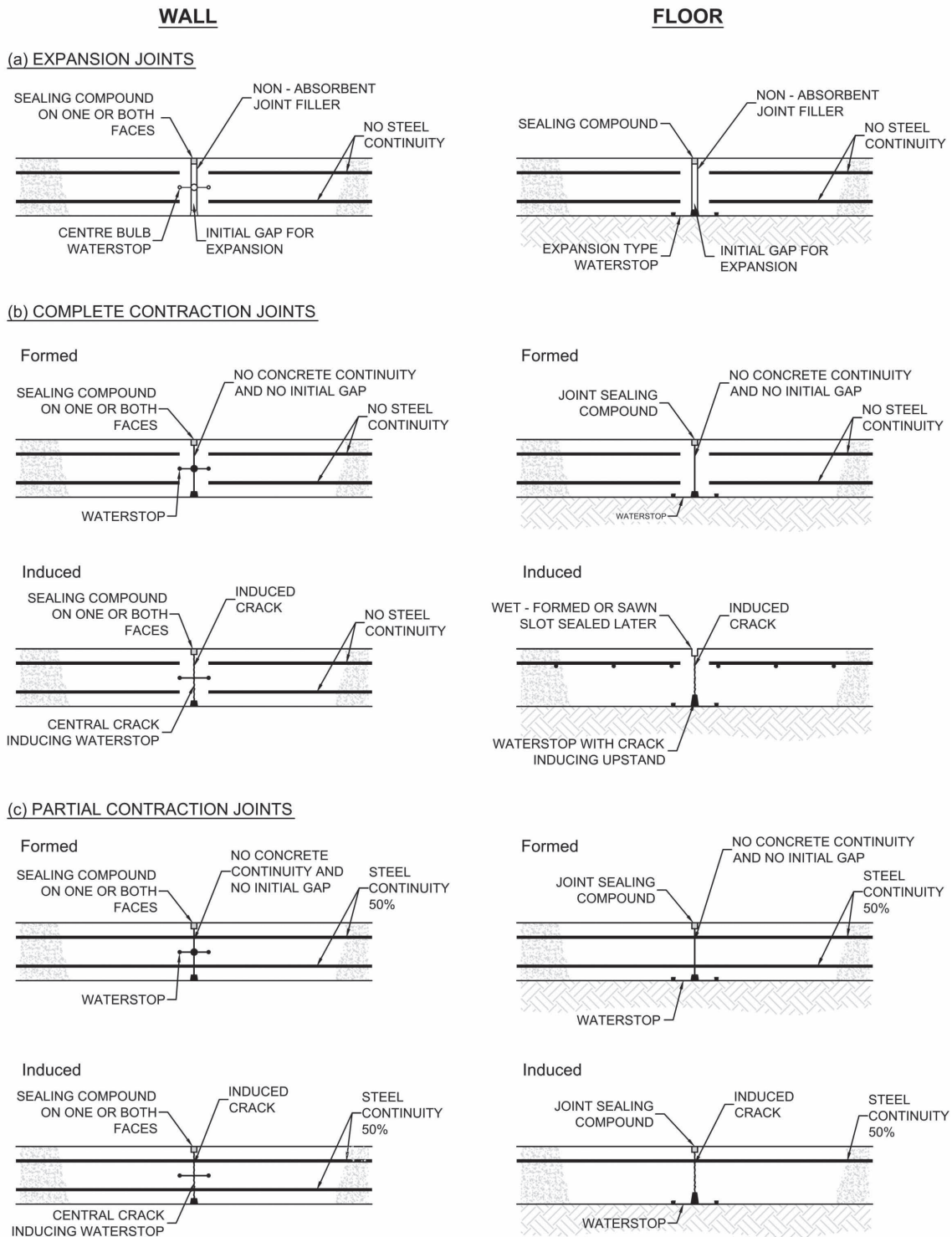

Figure A5.1 Typical details for expansion and contraction joints for the walls and bases of in situ reinforced concrete walls and bases (from BS 8007:1987)

A6 Typical details for an *in situ* reinforced concrete wall

For all but the smallest of *in situ* reinforced concrete bund, joints will be required between structural elements to facilitate construction and to allow movement (contraction and expansion of the walls and base). A typical arrangement of joints is shown by Figure A6.1.

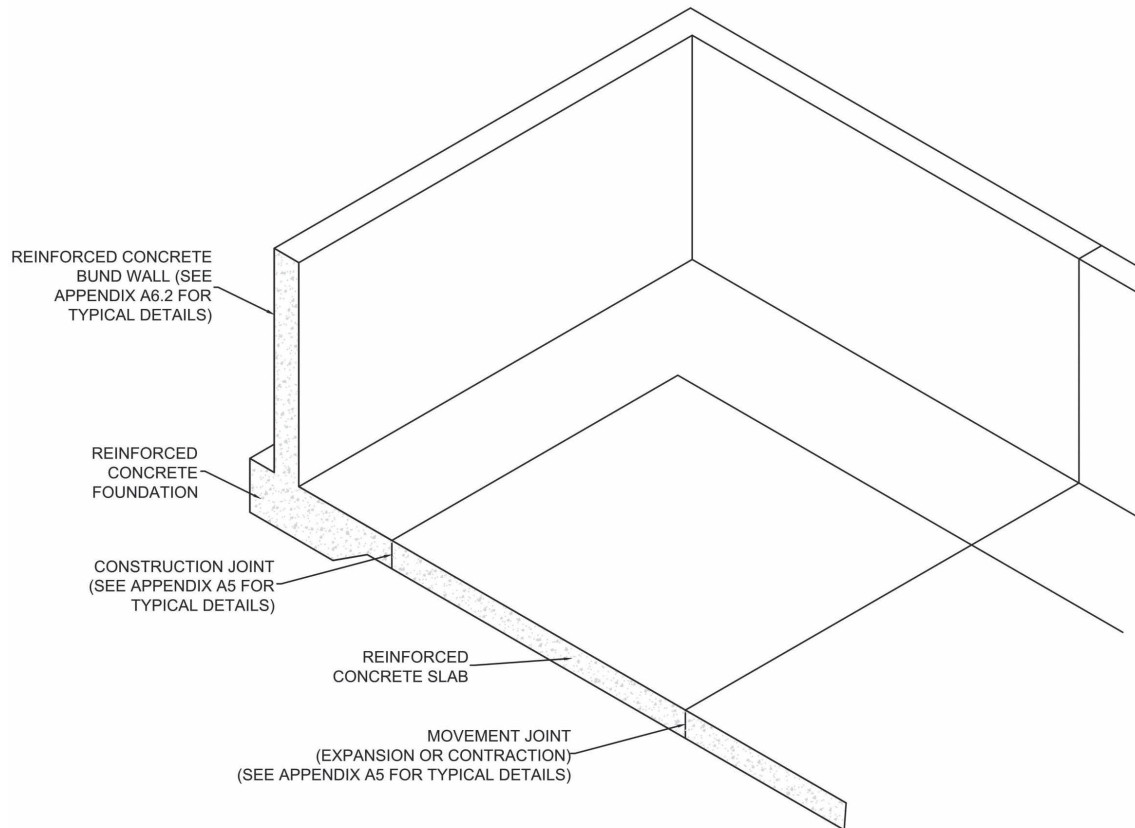

Figure A6.1 Typical arrangement of joints

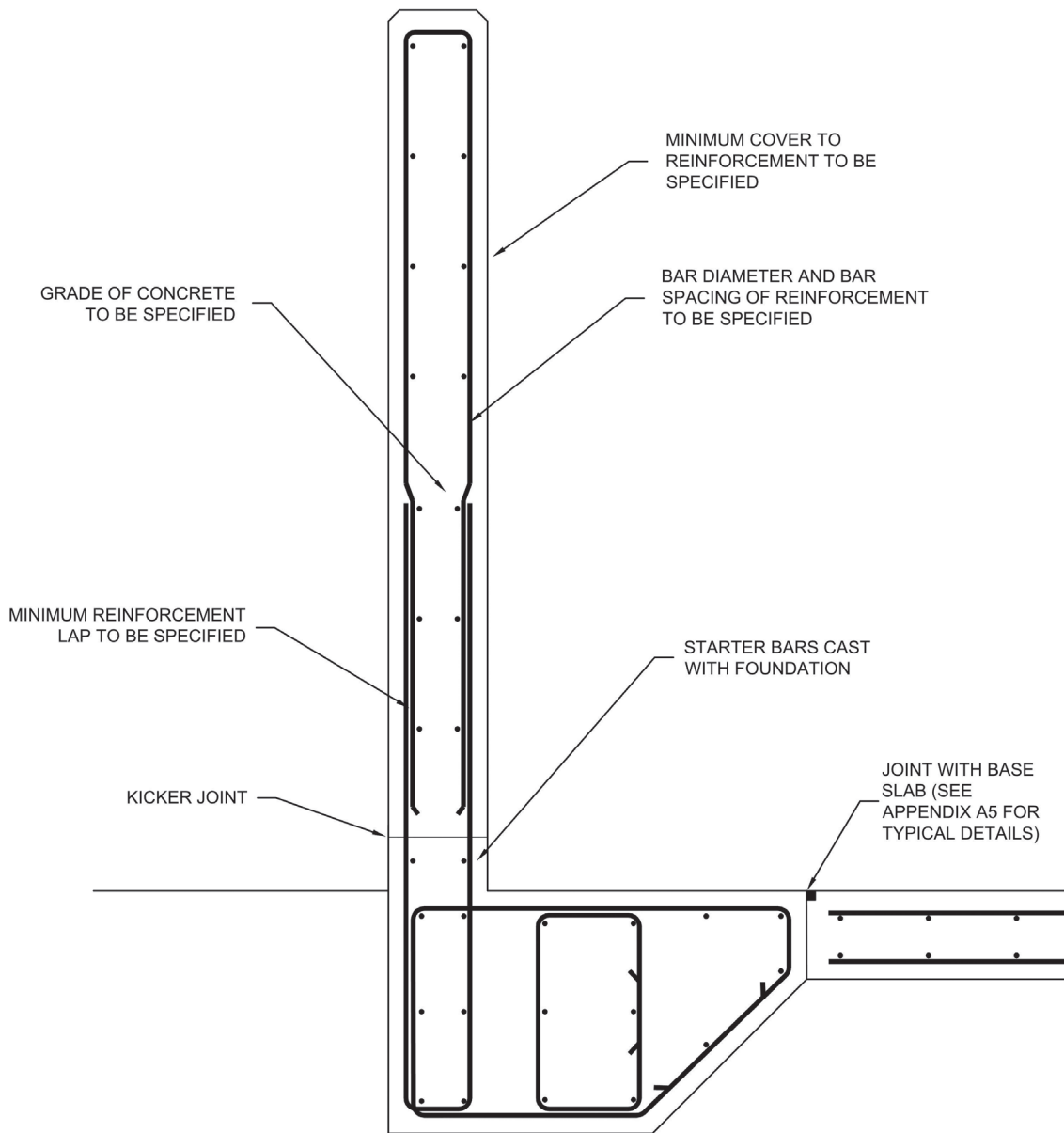

Figure A6.2 Typical in situ reinforced concrete wall detail

A7 Typical detail for a reinforced blockwork/brickwork wall

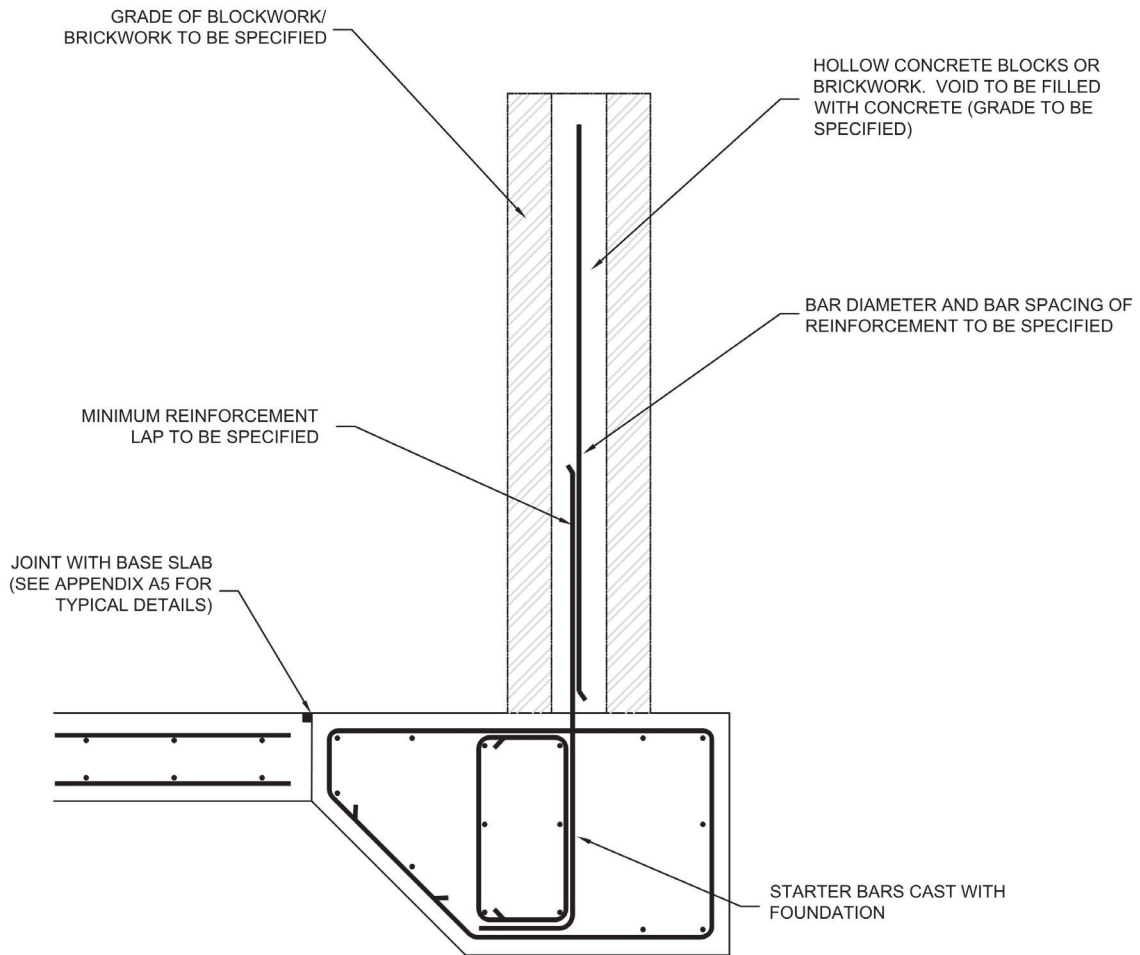

Figure A7.1 Typical detail for a reinforced blockwork/brickwork wall

A8 Typical details for earthwork lagoons and bunds

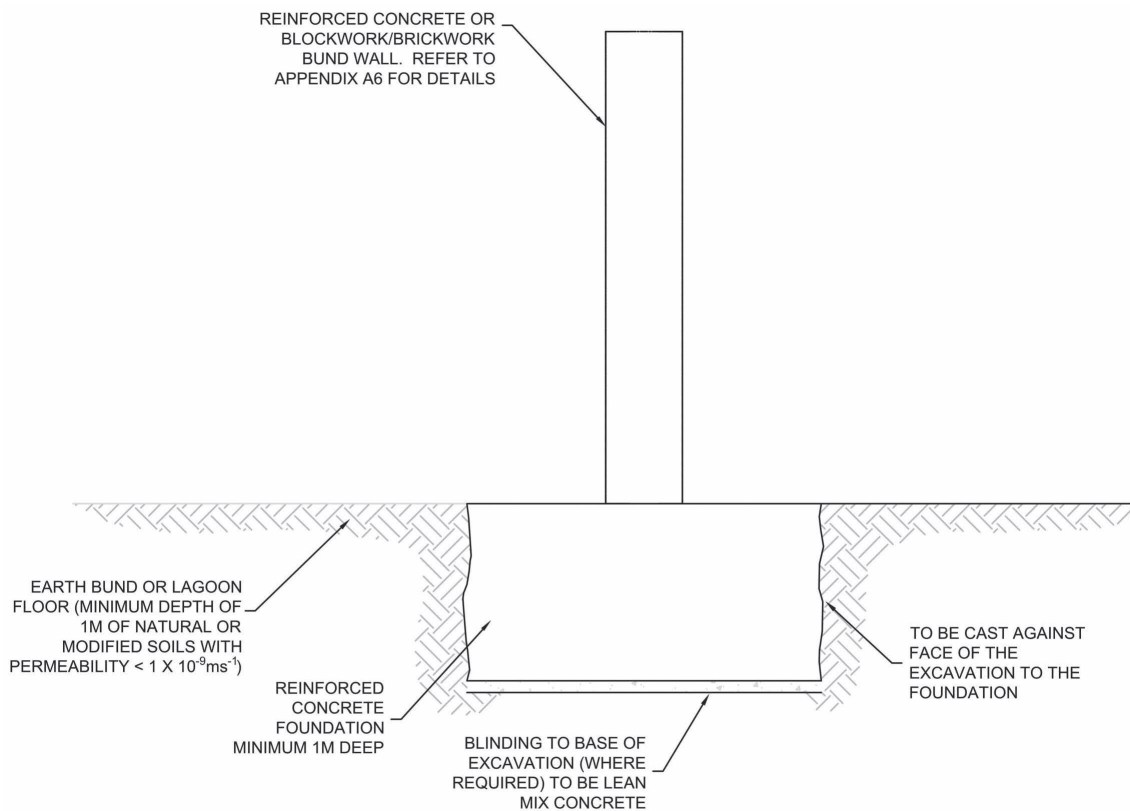

Figure A8.1 Foundation detail for in situ reinforced concrete or blockwork/brickwork bund wall with earth floor

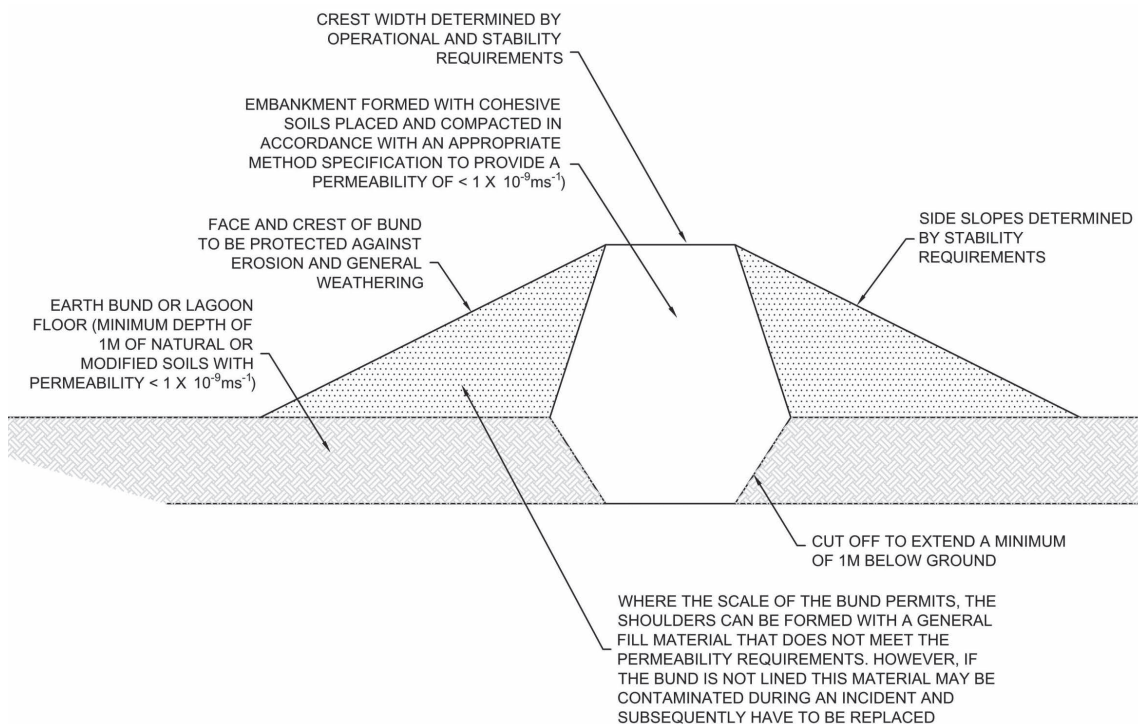

Figure A8.2 Typical earthwork or lagoon bund wall detail (see Section 8.10 for liner anchorage and protection details and pipe penetration details)

A9 Hydraulic pipe design

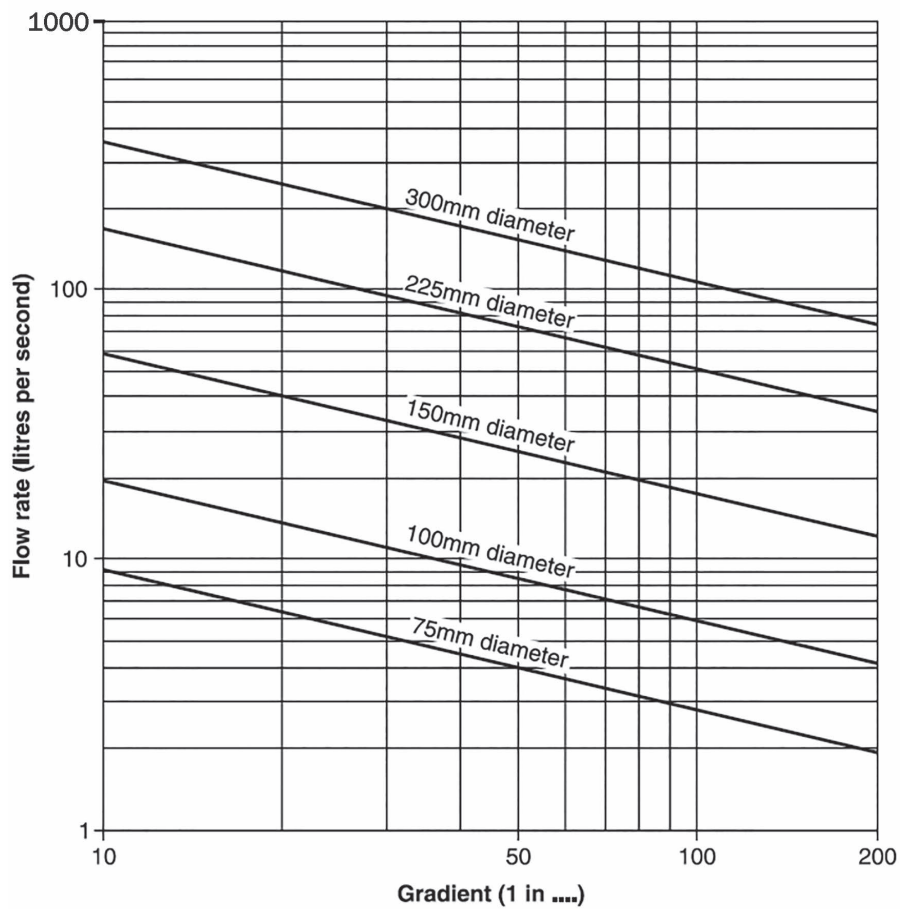

Figure A9.1 Discharge capacities of drains conveying water running full (from HM Government, 2010)

This chart is appropriate for clay or plastic pipework or a material with a similar roughness. Allowance has also to be made for head losses at bends, manholes and chambers.

Hydraulic design of drainage systems is commonly completed using a drainage analysis and design computer program. Available packages include WinDes® (MicroDrainage), xpswmm® (XP Solutions), and InfoWorks® (Innovyze).

A10 Concrete repair techniques

For more information readers should refer to BS EN 1504-9:2008.

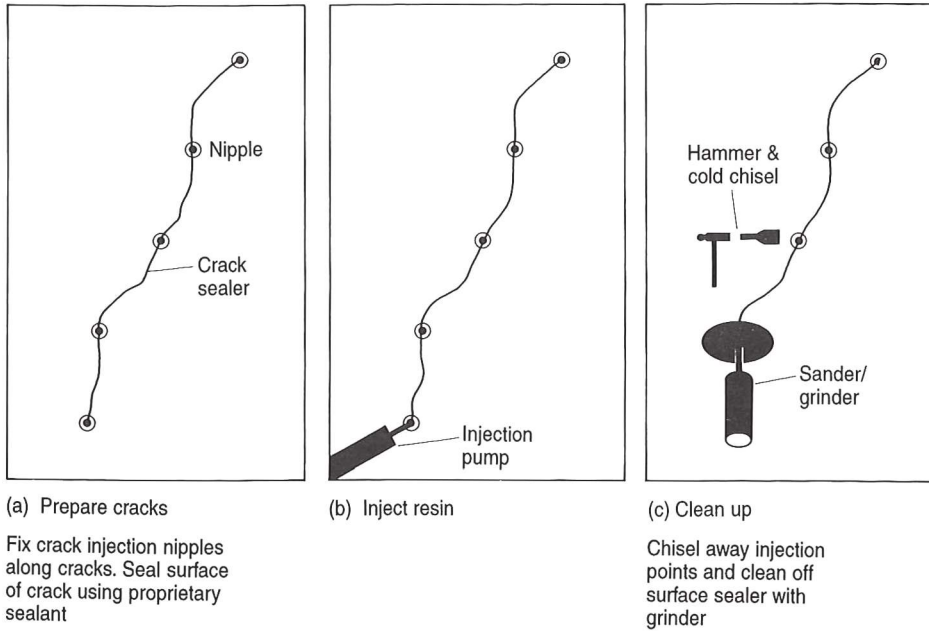

Figure A10.1 Concrete repair using resin injection (from Shaw, 1984)

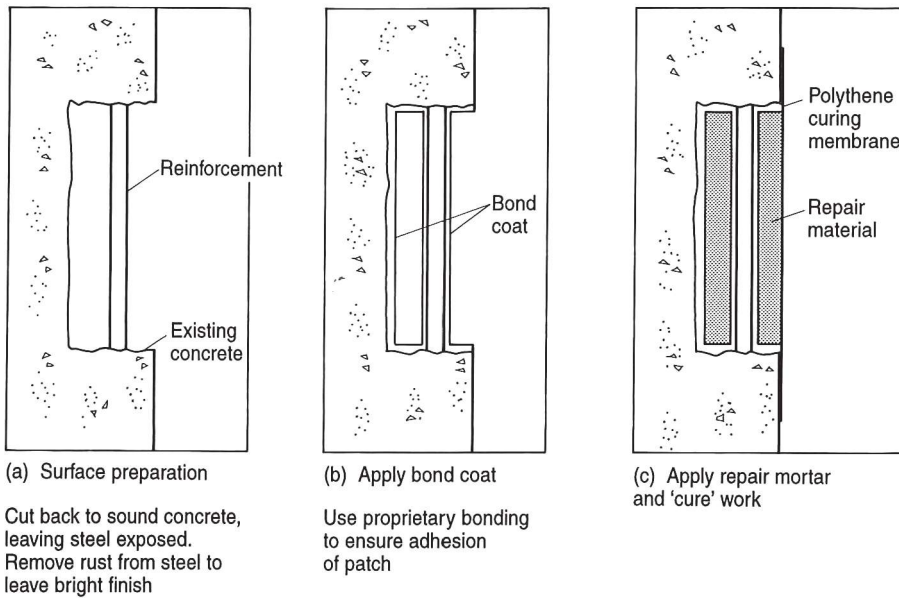
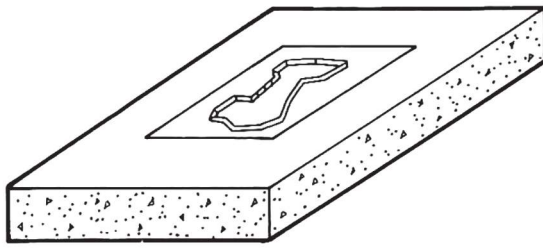

Figure A10.2 Patch repair to concrete (from Shaw, 1984)



(a) Mark out square or rectangular area around defect



(b) Chase out delineating groove around perimeter of repair



(c) Remove defective concrete from within repair area



(d) Thoroughly dampen area with water and/or apply primer as required



(e) Place and thoroughly compact repair material

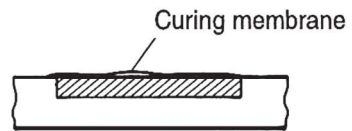

(f) Apply surface texture and cure immediately

Figure A10.3 Thin surface bonded repair to concrete (from Shaw, 1984)

Single-sided repair

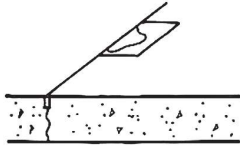

Double-sided repair

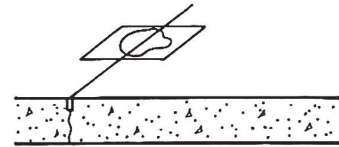

Mark out affected area



Chase around affected area and saw locating groove



Remove all unsound concrete from within repair area and clean out

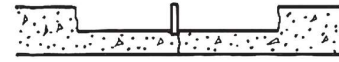
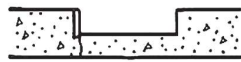

Securely fix joint former in locating groove to prevent bridging across crack.
Top 12 mm of former must be removable for application of joint sealer

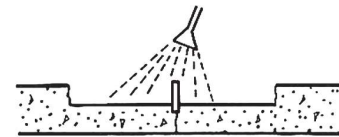

Thoroughly dampen area with water and/or apply primer as required



Place and thoroughly compact repair material

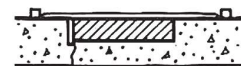

Cure immediately

After 24 hours remove top 12 mm of former to provide groove for sealant.
When concrete is mature, apply joint sealant on top of a bond breaker.

Figure A10.4 Thin surface bonded repair to concrete (from Shaw, 1984)



Core and Associate members

AECOM Ltd	Ministry of Justice
Arup Group Ltd	Morgan Sindall (Infrastructure) Plc
Atkins Consultants Limited	Mott MacDonald Group Ltd
Balfour Beatty Civil Engineering Ltd	MWH
BAM Nuttall Ltd	Network Rail
Black & Veatch Ltd	Northumbrian Water Limited
Buro Happold Engineers Limited	Rail Safety and Standards Board
BWB Consulting Ltd	Royal HaskoningDHV
Cardiff University	RSK Group Ltd
Environment Agency	RWE Npower plc
Galliford Try plc	Sellafield Ltd
Gatwick Airport Ltd	Severn Trent Water
Geotechnical Consulting Group	Sir Robert McAlpine Ltd
Golder Associates (Europe) Ltd	SKM Enviros Consulting Ltd
Halcrow Group Limited	SLR Consulting Ltd
Health & Safety Executive	Temple Group Ltd
Heathrow Airport Holdings Ltd	Thames Water Utilities Ltd
High Speed Two (HS2)	United Utilities Plc
Highways Agency	University College London
Homes and Communities Agency	University of Bradford
HR Wallingford Ltd	University of Reading
Institution of Civil Engineers	University of Salford
Lafarge Tarmac	University of Southampton
London Underground Ltd	WYG Group (Nottingham Office)
Loughborough University	

June 2014

This guide has been developed to assist owners and operators of industrial and commercial facilities storing substances (inventories) that may be hazardous to the environment.

It provides guidance on identifying the hazards, assessing the risks and mitigating the potential consequences of a failure of the primary storage facility and/or the combustion of its contents. A three-tier risk assessment methodology is introduced with recommendations for different 'classes' of construction for each.

It is applicable to the containment of a wide range of inventories and to all sizes of site from small commercial premises with a single storage tank, through to large chemical or petrochemical sites. It also applies to warehouses storing hazardous inventories.

Information is provided on the design, and construction of new secondary containment systems and the also the inspection, maintenance, repair, extension and upgrading of existing installations.

