



# User's Manual



# INSTALLATION INSTRUCTIONS

## Installation Manual

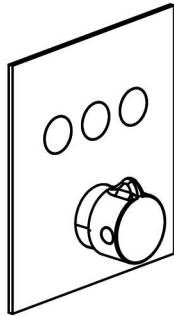
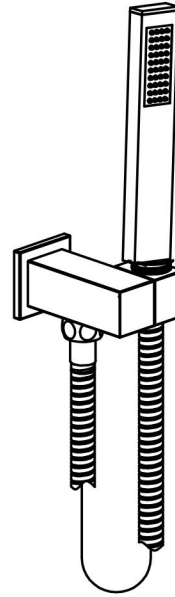
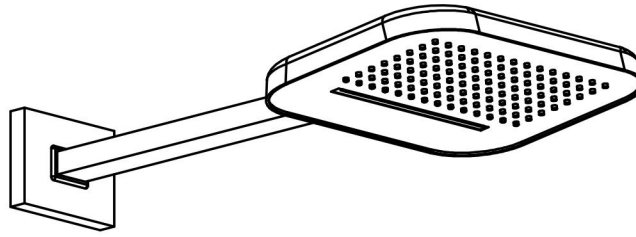

# RB1103

**IAPMO RESEARCH AND TESTING, INC.**  
5001 East Philadelphia Street, Ontario, California 91761-2816 • USA • 909-472-4100 • 909-472-4244 • www.iapmort.com

**CERTIFICATE OF LISTING**

 This certificate is not evidence of current listing. To verify listing status, visit the IAPMO R&T Product Listing Directory at [pld.iapmo.org](http://pld.iapmo.org)

Effective Date: December 2019 -Rev. 2/24/2020- Void After: December 2024  
Product: Flexible Water Connectors File No. 5311  
Issued To: Fanaki Group Inc.  
Mechanical & Electrical  
Industrial Zone,  
Yuhuan County,  
Yuhuan 317400, ZHEJIANG  
China

Identification: Products shall be marked with manufacturer's name or trademark, a statement "For use with water in accessible locations only." The product shall also bear the cUPC® certification mark. Markings shall be by means of either a permanent mark on the product, a label on the product or a tag attached to the product.

Characteristics: Flexible water connectors manufactured in various sizes, lengths and metal and fittings for hot or cold water applications that consist of an inner tube, which may or may not have an outer braided cover. Connectors are to be installed for use in accessible locations only. To be installed in accordance with the manufacturer's instruction, and the latest edition of the Uniform Plumbing Code and National Plumbing Code of Canada.

Products listed on this certificate have been tested by an IAPMO R&T recognized laboratory. This recognition has been granted based upon the

   
Chairman, Product Certification Committee CEO, The IAPMO Group

This listing is based upon the test data and the results indicated on the Effective Date and Void After Date shown above. Any change in material, manufacturing process, marking or design without having first obtained the approval of the Product Certification Committee, or any extension of manufacturing, will constitute a violation of the listing. This listing is not to be used for advertising purposes. Production of or reference to this listing for advertising purposes may be made only by specific, written permission of IAPMO Research and Testing, Inc. Any alteration of this certificate could be grounds for revocation of the listing. This document shall be reproduced in its entirety.

**IAPMO RESEARCH AND TESTING, INC.**  
5001 East Philadelphia Street, Ontario, California 91761-2816 • USA • 909-472-4100 • 909-472-4244 • www.iapmort.com

**CERTIFICATE OF LISTING**

 This certificate is not evidence of current listing. To verify listing status, visit the IAPMO R&T Product Listing Directory at [pld.iapmo.org](http://pld.iapmo.org)

Effective Date: November 2019 Void After: November 2024  
Product: Plumbing Fixture Fittings File No. 10633  
Issued To: Aqua Gallery Co., Ltd  
13th-15th A/D Block  
International Dynamics  
Sanitary City, 528000  
Foshan,  
China

Identification: Plumbing supply fittings complying with this Standard shall be marked with the manufacturer's recognized name, trademark, or other mark or, in the case of private labeling, the name, trademark or other mark of the customer for whom the fitting was manufactured. The marking shall be accomplished by use of a permanent mark or by placing a permanent label on the product. Markings on plumbing supply fittings shall be visible after installation.

Single-handle, single-control, and automatic compensating mixing bath and shower valves shall have identifiable temperature control settings in which the settings are indicated by words ("cold", "warm", "hot", etc.), by numbers, or graphically.

Packages shall be marked with the manufacturer's name, trademark, or other mark as well as the model number or, in the case of private

   
Chairman, Product Certification Committee CEO, The IAPMO Group

This listing is based upon the test data and the results indicated on the Effective Date and Void After Date shown above. Any change in material, manufacturing process, marking or design without having first obtained the approval of the Product Certification Committee, or any extension of manufacturing, will constitute a violation of the listing. This listing is not to be used for advertising purposes. Production of or reference to this listing for advertising purposes may be made only by specific, written permission of IAPMO Research and Testing, Inc. Any alteration of this certificate could be grounds for revocation of the listing. This document shall be reproduced in its entirety.

**IAPMO RESEARCH AND TESTING, INC.**  
5001 East Philadelphia Street, Ontario, California 91761-2816 • USA • 909-472-4100 • 909-472-4244 • www.iapmort.com

**CERTIFICATE OF LISTING**

 This certificate is not evidence of current listing. To verify listing status, visit the IAPMO R&T Product Listing Directory at [pld.iapmo.org](http://pld.iapmo.org)

Effective Date: March 2019 Void After: March 2024  
Product: Plumbing Fixture Fittings - Components File No. MC-9703  
Issued To: Ningbo Nantai Cartridge Technology Co., Ltd.  
Lincheng Zone, Chunhui  
Fengpu, JIANGSU 215518  
China

Identification: Each fitting component shall bear permanent legible markings to identify the manufacturer. This marking shall be the trade name, trademark, or other mark known to identify the manufacturer. The product shall also bear all other markings required by the standards. The marking shall be applied so as to be visible after installation. The product or packaging shall also bear the cUPC® certification mark along with the term "COMPONENT" above.

Characteristics: Plumbing fixture fitting components to be installed in accordance with the manufacturer's instructions and the requirements of the latest edition of the Uniform Plumbing Code.

Products listed on this certificate have been tested by an IAPMO R&T recognized laboratory. This recognition has been granted based upon the Laboratory's compliance to the applicable requirements of ISO/IEC 17025.

Products are in compliance with the following code(s):  
Uniform Plumbing Code (UPC®)

   
Chairman, Product Certification Committee CEO, The IAPMO Group

This listing is based upon the test data and the results indicated on the Effective Date and Void After Date shown above. Any change in material, manufacturing process, marking or design without having first obtained the approval of the Product Certification Committee, or any extension of manufacturing, will constitute a violation of the listing. This listing is not to be used for advertising purposes. Production of or reference to this listing for advertising purposes may be made only by specific, written permission of IAPMO Research and Testing, Inc. Any alteration of this certificate could be grounds for revocation of the listing. This document shall be reproduced in its entirety.

# BEFORE INSTALLATION

## Usage

As shown in the right, the water outflow can be turned on or off independently by the switch button, and the water temperature can be adjusted by the constant temperature hand wheel on the right.

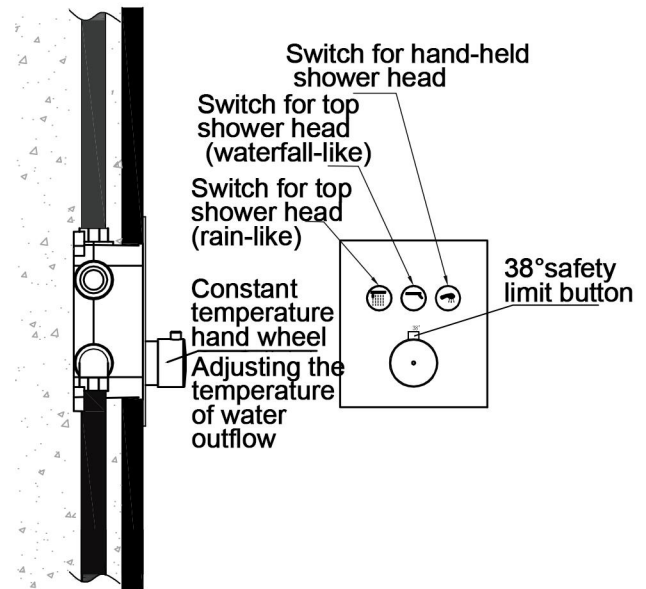

## Notes

1. The valve core of the main body has been tested and adjusted by the manufacturer. Please do not disassemble and install it by yourself.
2. Hot water temperature 55-80 °C (recommended 65 °C), cold water temperature 5-29 °C (recommended 15 °C).
3. Cold water should be connected to the main body on the side marked with "C", and hot water on the side marked with "H". Reversed connection is strictly prohibited. The water pressure at the cold and hot water inlet should not vary too much (pressure difference between the two ends  $\leq 20\%$ ).
4. The working water pressure of the valve core is 0.1-0.5 MPa (including the pressure of cold or hot water). Working water pressure of 0.3 MPa is recommended to use. A pressure reducing valve should be installed on the pipeline when the working water pressure exceeds 0.5 MPa.
5. The temperature displayed on the constant temperature handwheel is adjusted under the specific water temperature condition in the factory. The product may be different as the working water temperature changes. The difference of  $\pm 2$  °C is normal. If there is large difference, it should be adjusted by professional personnel.

## Piping Diagram

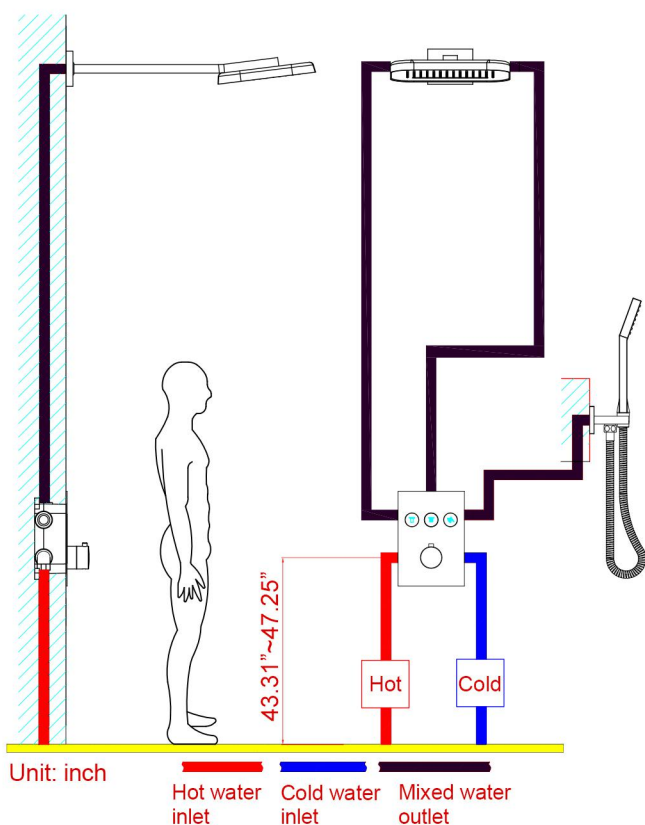

## Installation of Main Body Parts list

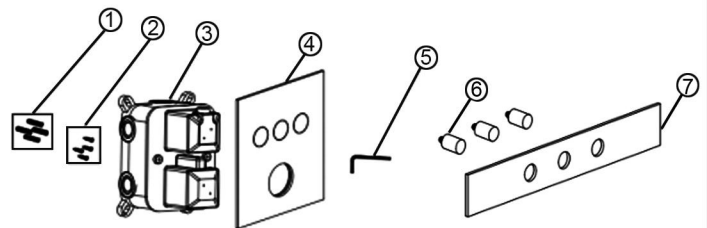

NO.	Name	Quantity
1	Expansible colloidal particle	4
2	Self-tapping screw	4
3	Pre-embedded main body	1
4	Decorative panel	1
5	2.5mm hexagon wrench	1
6	Extension rod	3
7	Locating plate	1

# INSTALL THE SHOWER VALVE BODY

This product has been inspected and debugged by the factory to the best condition. Please do not disassemble and assemble it yourself.

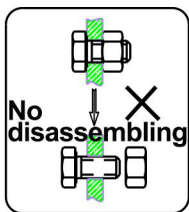

Before installing the product, please be sure to remove sundries and sludge from the water pipe to prevent sundries from blocking the product.

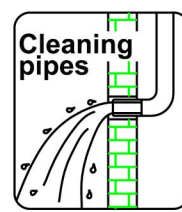

1. According to the basic size of the product (with reference to the figure above), the pre-embedded grooves of main body, inlets of hot and cold water and mixed water outlets and joints should be excavated.

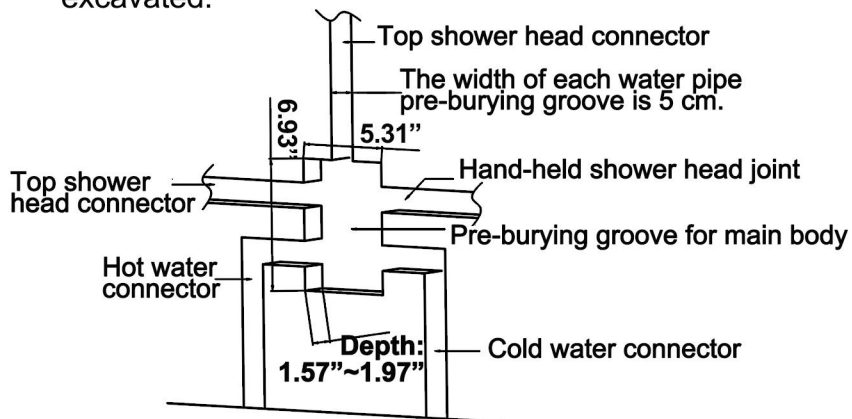

2. Drill four 6-mm holes with percussion drill according to the product size.

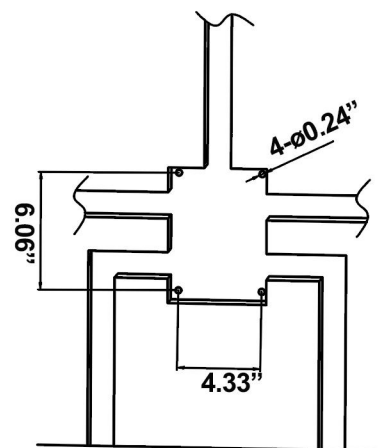

3. Drive 4 expansible colloidal particles into the drilled holes with hammer.

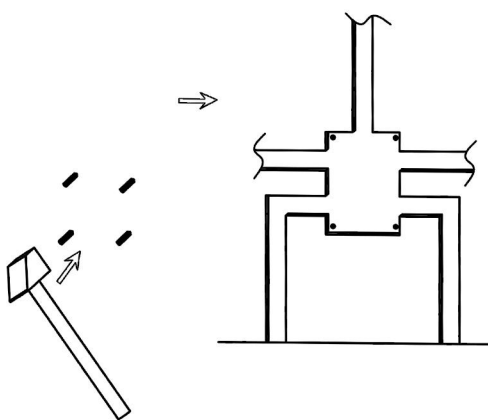

4. Each pipe should be linked and connected to water to confirm there is no leakage.

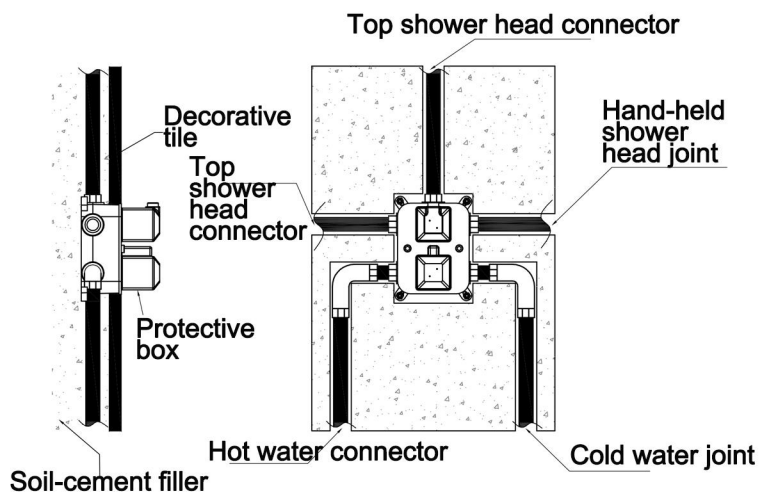

5. Adjust the pre-embedded main body to the horizontal line and fix the main body on the wall with four self-tapping screw and a cross screwdriver. Seal the pipeline with cement filler.

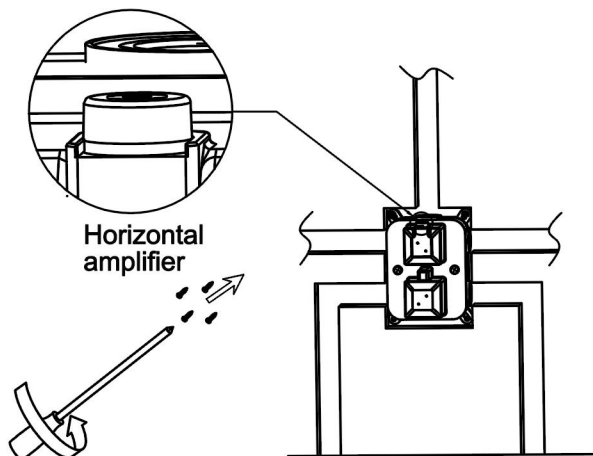

6. Loosen the two M5 screws on the sheath counterclockwise with a cross screwdriver and remove the sheath.

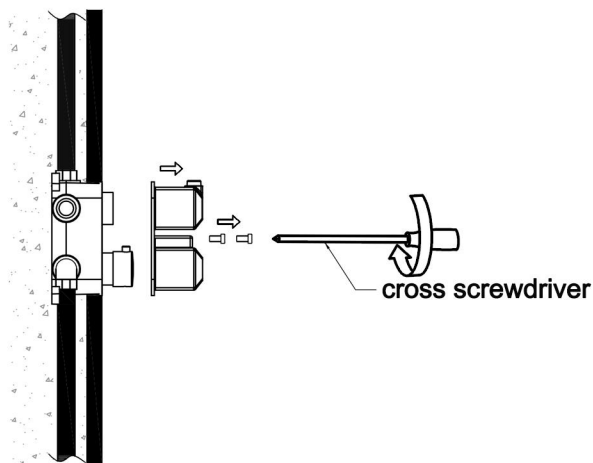

# INSTALL THE SHOWER VALVE BODY

7. First, take out the color button of the constant temperature handwheel; then loosen the main body of the handwheel counterclockwise with the 2.5-mm hexagon wrench, and unload it. Do not rotate the constant temperature handwheel when taking it out. Ensure that the button of the constant temperature handwheel is aligned with the 38-degree line on the panel.

8. Tighten the three extension rods on the valve core with button; then put the positioning plate on the surface of wall; cut off the redundant part by cutting machine or the blade along the outer plane of the extension rod of positioning plate; finally, remove the positioning plate again (as shown in the figure).

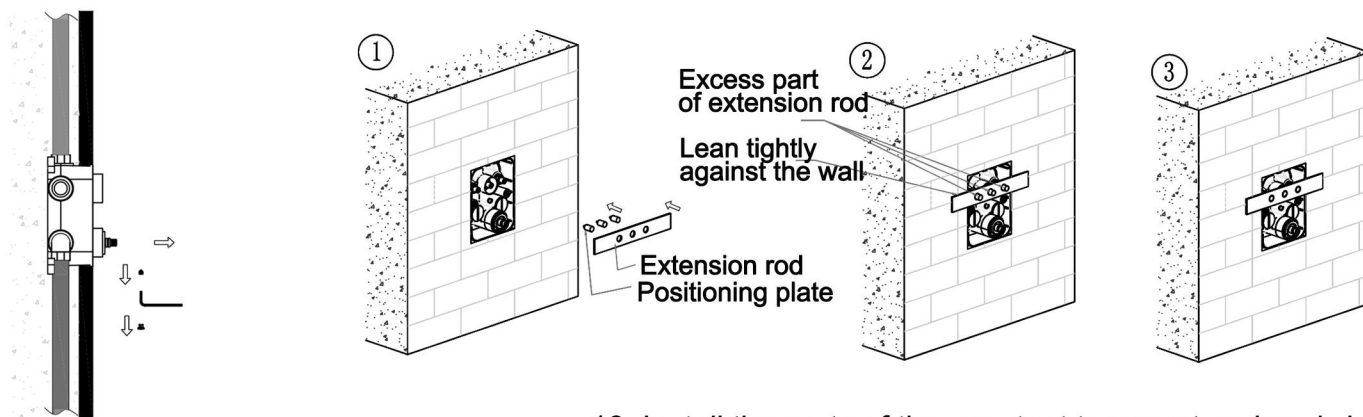

9. Install the panel on the main body in a balanced manner.

10. Install the parts of the constant temperature handwheel on the main body in the opposite direction of unloading. (please ensure that the valve core does not rotate when installing the constant temperature hand wheel and the direction of the button is aligned with the direction of the outlet pipe.)

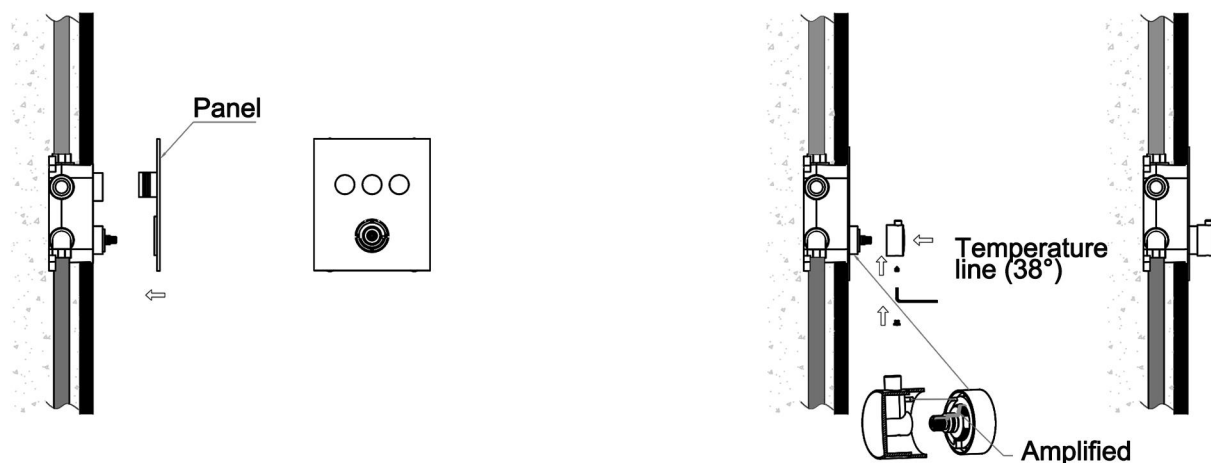

# INSTALLATION OF THE HAND SHOWER

1. Wrap the PTFE tape on the 1/2 thread of the stand for shower head.

2. Screw the stand for shower head clockwise on the outlet hole of the water outlet.

3. Connect the water outlet of the stand for shower head with the tube of shower head, and put the hand-held shower head in the stand.

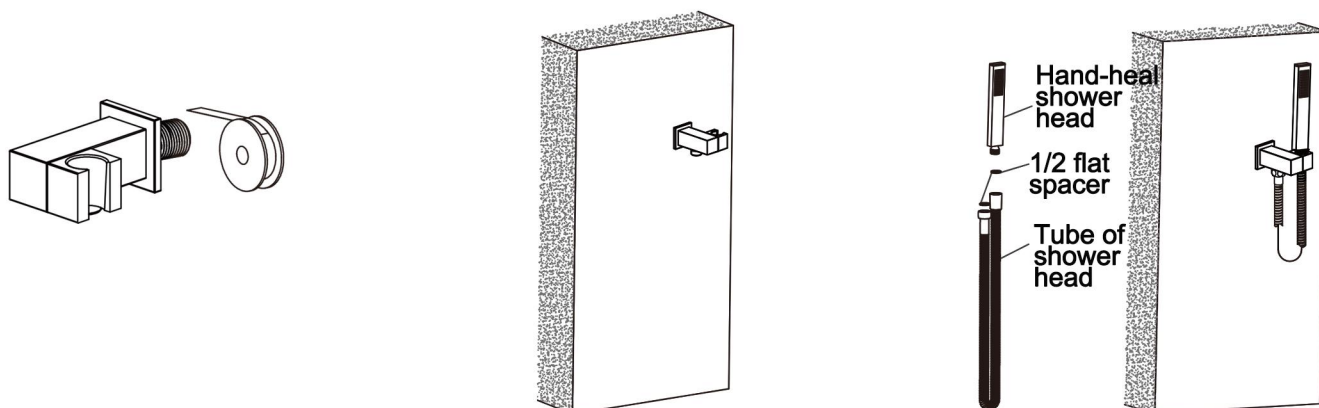

# INSTALLATION OF RAIN SHOWER HEAD

## Parts list

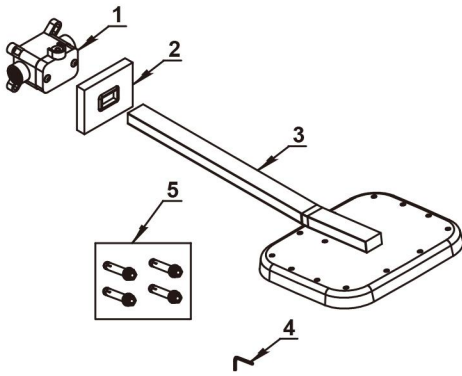

NO.	Name	Qty
1	Pre-embedded main body	4
2	panel	1
3	Parts of shower head	1
4	2.5mm hexagon wrench	1
5	Explosion screw	1

## Sketchy diagram

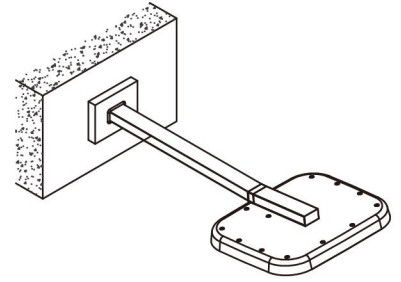

# INSTALLATION OF RAIN SHOWER HEAD

1. Dig the main body pre-embedment outlet, inlet pipe1 and inlet pipe2 on the wall according to the main body size drawing.

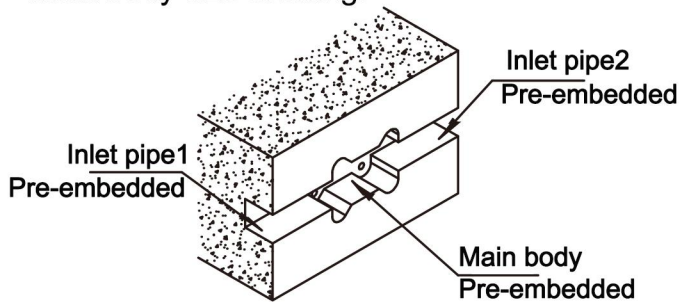

2. Drill four Ø0.31" holes on the wall where the pre-embedded holes have been dug based on the basic dimensions of the fixed holes.

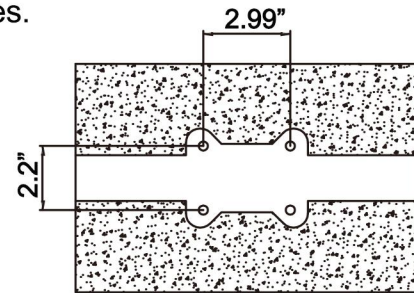

3. The pre-embedded main body is sealed with PTFE tape to connect the two water inlet pipes, and tighten them with vigorously pliers to confirm that there is no water leakage.

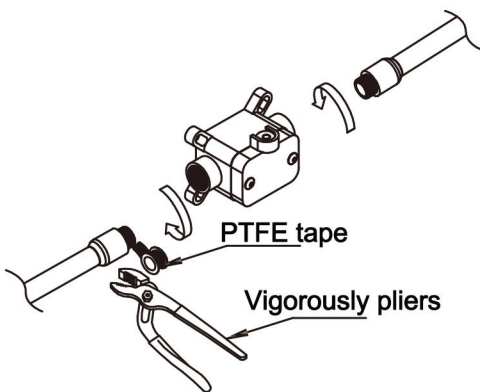

4. Adjust the level and position of the embedded main body that has been connected to the water pipe. Use four explosive screws to fix the embedded main body. Then seal the wall with concrete filler in the already dug embedded hole.

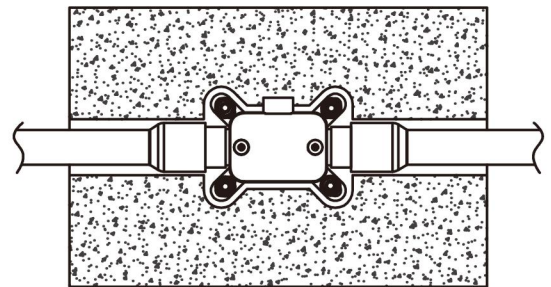

5. Put the panel on the shower arm of the shower assembly, the direction is as shown in the figure.

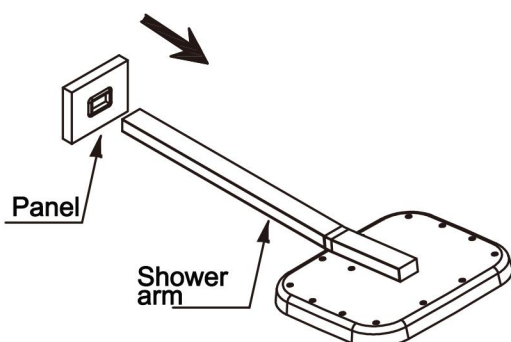

6. Use a screwdriver to loosen the two screws on the embedded main body and remove the sheath.

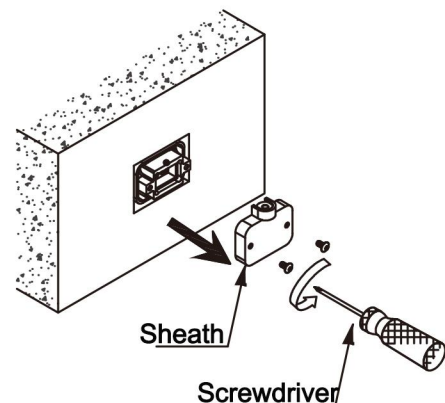

# INSTALLATION OF RAIN SHOWER HEAD

7. Insert the shower assembly into the embedded body.

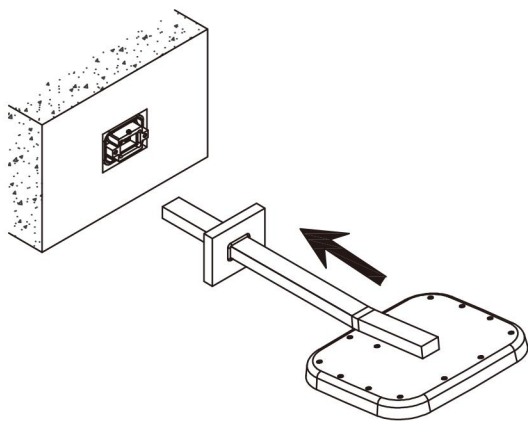

8. Tighten the shower head screws with a hexagon wrench.

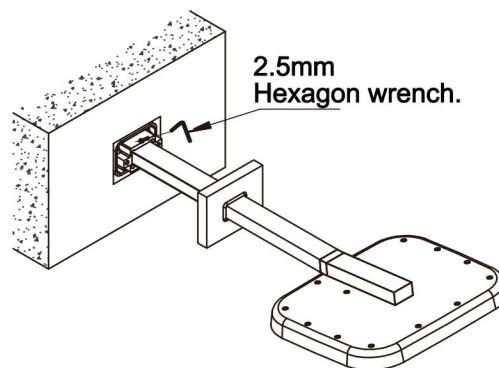

9. Press the panel tightly against the wall.

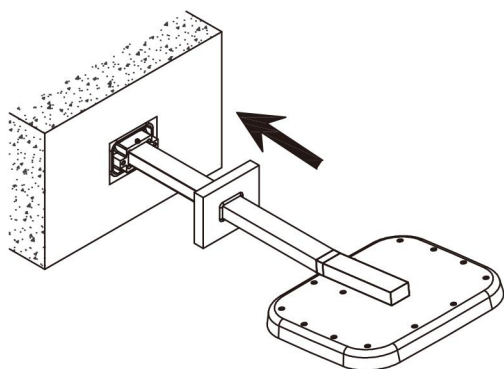

## CLEANING CARE

1. To keep the surface of the product clean and bright, please wash it frequently:

- A. Rinse with water and dry with soft cotton cloth;
- B. Do not use abrasive detergent, emery cloth and sandpaper;
- C. Do not use any acid cleaner, polish, soap, coarse detergent, abrasive polish.

2. When the water outflow is reduced or the temperature is difficult to adjust, please follow the following steps to remove the impurities on the filter screen: (as shown above)

- A. Disassemble the inlet parts on both sides of the main body with tools;
- B. Brush the impurities attached to the filter screen on the backwater-proof inlet;
- C. Reinstall the parts sequentially, and then open the supply of cold and hot water on the body part.

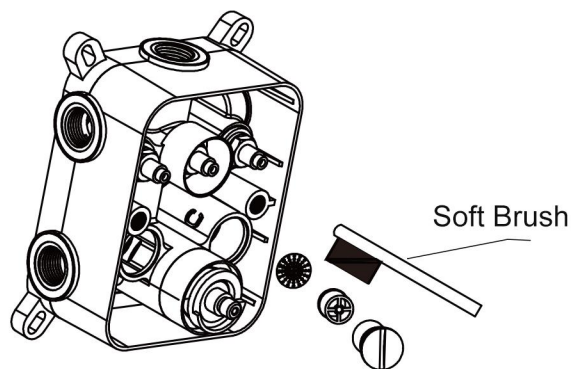

Please feel free to contact us if you have any questions. We will help to solve the issue together with you. OUR EMAIL: [services@rbrohant.com](mailto:services@rbrohant.com)



Service Contact:  
**+1(801) 800-9309**  
**services@rbrohant.com**

Made in China