



Read all instructions
before assembly and use.
KEEP INSTRUCTIONS FOR
FUTURE USE.

Lisez toutes les instructions avant
l'assemblage et l'utilisation.
CONSERVEZ LES INSTRUCTIONS
POUR UN USAGE ULTERIEUR.

Lea todas las instrucciones
antes de ensamblar y usar.
MANTENGA LAS INSTRUCCIONES
PARA SU USO FUTURO.



Bunk Bed
Lit Mezzanine
Cama Litera

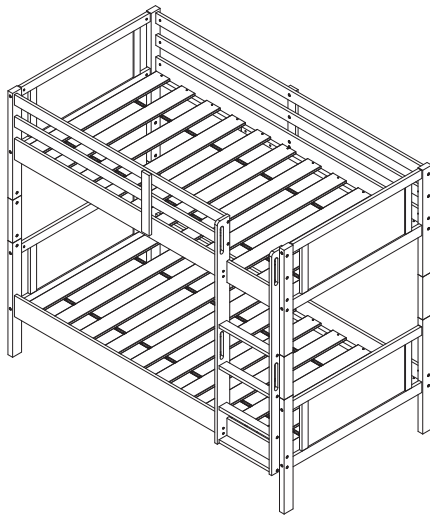

⚠ ADULT ASSEMBLY REQUIRED

Due to the presence of small parts during assembly, keep out of reach of children until assembly is complete.

⚠ L'ASSEMBLAGE DOIT ETRE FAIT PAR UN ADULTE

A cause de la presence de petites pieces, pendant l'assemblage gardez hors de portee des enfants jusqu'a ce que celui-ci soit termine.

⚠ DEBE SER ENSAMBLADO POR UN ADULTO

Debido a la presencia de piezas pequeñas durante el ensamblaje, mantenga fuera del alcance de los niños hasta que complete el ensamblaje.

This product is not intended for institutional or commercial use.
Ce produit ne pas destine a un usage institutionnel ou commercial.
Este producto no esta hecho para uso institucional o comercial.

NEED EXTRA HELP?

We make assembly easy with
our tips & tricks video
[https://www.deltachildren.com/
pages/instructions](https://www.deltachildren.com/pages/instructions)

BESOIN D'AIDE SUPPLÉMENTAIRE?

Nous facilitons l'assemblage avec
nos trucs et astuces vidéo
[https://www.deltachildren.com/
pages/instructions](https://www.deltachildren.com/pages/instructions)

¿NECESITA AYUDA EXTRA?

Hacemos el montaje fácil con
nuestros consejos y trucos video
[https://www.deltachildren.com/
pages/instructions](https://www.deltachildren.com/pages/instructions)

When contacting Delta Consumer Care, please reference the information on the Product Information label found on the product.

Lorsque vous contactez le Service après Vente de Delta, veuillez nous donner les références sur l'étiquette d'Information qui se trouve sur le produit.

Cuando contacte al Servicio de Atención al Consumidor de Delta por favor mencione los datos que aparecen en la etiqueta de información que se encuentra en el producto.

DELTA CHILDREN'S PRODUCTS CORP
114 WEST 26TH STREET. M / #: xxxxx
NEW YORK, NY 10001. PO #: xxxxx LOT #: xxxxx
Email: tcs@DeltaChildren.com D. O. M.: xxxxx
TEL.: 646-435-8728 Base Model: BW303
MADE IN MALAYSIA TSCA VI

Product information label
L'étiquette d'information
Etiqueta de información



Consumer Care:

Delta Children's Products Corp
114 West 26th Street New York, NY 10001
Tel: (646) 435-8728

Email: tcs@DeltaChildren.com

<https://www.deltachildren.com/pages/instructions>

©2021 DELTA ENTERPRISE CORP.



SAVE BIG WITH DELTA CHILDREN

Visit Deltachildren.com To Start Shopping

Welcome to the
DELTA FAMILY
Here's a Gift From Us To You

10% OFF

Your Next Purchase From
DeltaChildren.com

USE CODE:
DELTA10

*Exclusions Apply
*Subject to Change

REVIEW TO WIN \$2500

RULES TO ENTER



"We LOVE, LOVE, LOVE this crib"

My husband was impressed with the directions and organization of the hardware package. He easily assembled this crib in an hour without any help. It's very sturdy and we like that it has adjustable levels for the mattress height. To top it all off, it's so incredibly darling!!!

- 1** **WRITE A REVIEW** for this product on the store's website from where it was purchased
- 2** **TAKE A SCREENSHOT** of your review and upload it to www.DeltaChildren.com/Review
- 3** **IT'S THAT EASY!** Upon submission, you'll be instantly **ENTERED TO WIN \$2,500**

FOLLOW US FOR MORE CHANCES TO WIN

[@deltachildren](https://www.instagram.com/deltachildren)

SCAN HERE



For more information
and to see all of our
products





WARNING

- Follow the information on the warnings appearing on the upper bunk end structure and on the carton. **DO NOT** remove warning label from bed.
- Always use the recommended size mattresses or mattress supports, or both, to help prevent the likelihood of entrapment or falls.
- Surface of mattress must be at least 5". (127 mm) below the upper edge of guardrails.
- Upper Bunk Mattress Specification:
 - Only use a mattress that is 74" - 75" long and 37 ½" – 38 ½" wide on upper bunk.
 - Ensure thickness of mattress does not exceed 8".
- Lower Bunk Mattress Specification:
Only use a mattress that is 75" long and 39" wide on lower bunk.
Ensure thickness of mattress is 7" only.
- **DO NOT** allow children under 6 years of age to use the upper bunk.
- Periodically check and ensure that the guardrail, ladder, and other components are in their proper position, free from damage, and that all connectors are tight.
- **DO NOT** allow horseplay on or under the bed and prohibit jumping on the bed.
- Use of a night light may provide added safety precaution for a child using the upper bunk.
- **DO NOT** substitute parts. Replacement parts, including additional guardrails, may be obtained from Delta Children's Products dealers that carry this item or by contacting Delta Consumer Care.
- Always use the ladder for entering and leaving the upper bunk.
- Always use guardrails on both long sides of the upper bunk. If the bunk bed will be placed next to the wall, the guardrail that runs the full length of the bed should be placed against the wall to prevent entrapment between the bed and wall.
- The use of water or sleep flotation mattresses is prohibited.
- Prohibit more than one person on upper bunk.
- **STRANGULATION HAZARD**—Never attach or hang items to any part of the bunk bed that are not designed for use with the bed; for example, but not limited to, hooks, belts and jump ropes.
- Keep these instructions for future reference.



AVERTISSEMENT

- Suivez les informations des avertissements apparaissant sur l'extrémité du cadre du lit en hauteur et sur le carton. Ne pas retirer l'étiquette d'avertissement du lit.
- Toujours utiliser la taille de matelas ou support de matelas recommandés, ou les deux, pour prévenir le risque de piégage ou de chute.
- La surface de matelas doit être au moins 5 pouces. (127mm) en dessous du bord supérieur de la barre de sécurité.
- Caractéristiques du matelas superposé supérieur:
 - Uniquement utiliser un matelas de 74" – 75" de long et 37 ½" – 38 ½" de large sur le lit superposé supérieur.
 - S'assurer que l'épaisseur du matelas ne dépasse pas 8".
- Caractéristiques du matelas superposé inférieur:
 - Uniquement utiliser un matelas de 75" de long et 39" de large sur le lit superposé inférieur.
 - S'assurer que l'épaisseur du matelas est de 7" uniquement.
- **NE PAS** autoriser un enfant de moins de 6 ans utiliser le lit en hauteur.
- Fréquemment vérifier et s'assurer que la barre de sécurité, l'échelle, et les autres composants sont dans leurs positions correctes, sans dommage, et que tous les connecteurs sont serrés.
- **NE PAS** laisser l'enfant se mettre à cheval sur ou en dessous du lit et interdire de sauter sur le lit.
- **NE PAS** remplacer des pièces. Des pièces de rechange, y compris des rambardes de sécurité supplémentaires, sont disponibles auprès des magasins Delta Children's Products qui vendent cet article, ou en contactant le Service Client de Delta.
- Utiliser une lampe de nuit peut apporter une précaution de sécurité supplémentaire pour l'enfant utilisant le haut du lit.
- Toujours utiliser les barres de sécurité sur les deux côtés du lit en hauteur. Si le lit superposé sera placé à côté du mur, la barre de sécurité se trouvant près du mur devra être contre le mur pour prévenir le risque de piégage ou de chute.
- L'utilisation de matelas d'eau ou de flottaison est interdit.
- **RISQUE D'ÉTRANGLEMENT** - Ne jamais attacher ou laisser pendre des objets à n'importe quel endroit du lit superposé qui ne sont pas faits pour l'utilisation de ce lit; par exemple, mais ne se limite pas à ceci, crochets, ceintures et cordes à sauter
- Gardez ces instructions pour future référence.



ADVERTENCIA

- Siga las advertencias que aparecen en uno de los extremos de esta cama litera y en la caja de este producto. **NO** remueva la etiqueta de advertencia de la cama.
- Siempre utilice el tamaño recomendado de colchón o soporte o ambos, para prevenir posibles atrapamientos o caídas.
- Asegúrese de que el espesor del colchón esté al menos 5" debajo del borde superior de barandas.
- Características del colchón de litera superior:
 - Utilice únicamente un colchón de 74" - 75" de largo y 37 ½" - 38 ½" de ancho en la litera superior.
 - Asegúrese de que el espesor del colchón no supere las 8".
- Características del colchón de litera inferior:
 - Utilice solo un colchón de 75" de largo y 39" de ancho en la litera inferior.
 - Asegúrese de que el colchón tenga solo 7" de espesor.
- **NO** permita que niños menores de 6 años utilicen la litera superior. Verifique periódicamente que las barandillas, escalera y otros componentes estén en la posición adecuada, libre de daños, y que todas las conexiones estén correctamente apretadas.
- **NO** permita juegos bruscos sobre o debajo de la cama.
- Use siempre la escalera para subir y bajar de la parte superior litera.
- **NO** sustituya piezas. Piezas de reemplazo, incluyendo barandas de seguridad, pueden ser obtenidas a través de los distribuidores de Delta Children que vendan este producto o comunicándose con Atención al Consumidor de Delta Children.
- Usar luz nocturna quizá proporcione seguridad adicional al niño que utilice esta cama litera.
- Siempre use barandas de seguridad en ambos lados largos de camas litera. Si la litera está colocada junto a la pared, las barandas de seguridad que recorre toda la cama debe colocarse contra la pared para evitar atrapamientos entre la cama y la pared.
- El uso de colchones de agua o colchones inflables está prohibido en esta cama.
- **PELIGRO DE ESTRANGULACIÓN**
NUNCA coloque o cuelgue artículos en ninguna parte de la cama litera que no sean diseñados para el uso esta; por ejemplo, pero no limitado a, ganchos, correas y cuerdas de saltar.
- Mantenga estas intrucciones para futuras referencias.



Hardware Kits Part#34273

L'ensemble de quincaillerie - pièce n°34273

El Kit De Herramientas - Pieza #34273

Note: Fasteners are shown full size
 Remarque: Les dispositifs de fixation sont montrés en taille réelle
 Nota: Los pernos se muestran en tamaño real



Required Tools
 Outils Nécessaires
 Herramientas necesarias



AA x24

M10x35mm

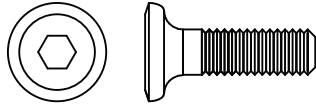

BB x16

M6x20mm

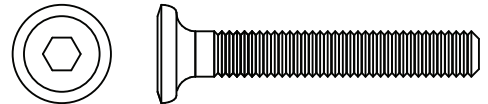

CC x2

M6x40mm



EE x22

M6x70mm

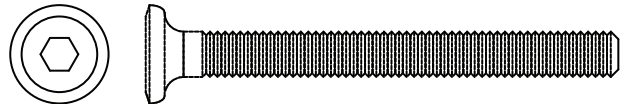

DD x14

M6x60mm

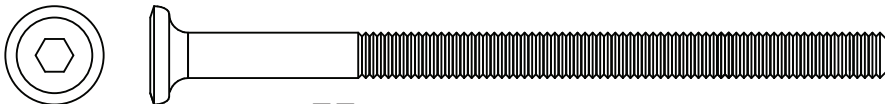

FF x16

M6x95mm

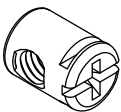

GG x52

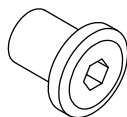

HH x2

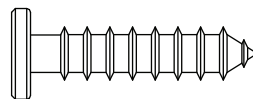
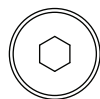

JJ x8

30mm



KK x44

32mm

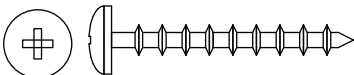

LL x3

32mm

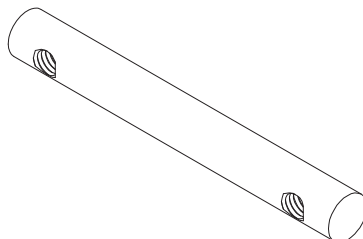

MM x8

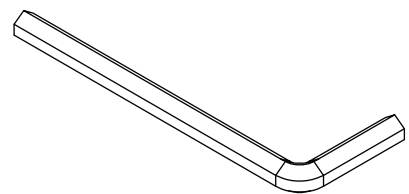

NN x2



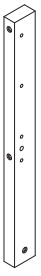

A x2
34251



B x1
34252



C x1
34253

TOP HEADBOARD POST
SUPPORT SUPÉRIEUR DE TÊTE DE LIT
POSTE SUPERIOR DE LA CABECERA



D x2
34256



E x1
34257



F x1
34258

BOTTOM HEADBOARD POST
SUPPORT INFÉRIEUR DE TÊTE DE LIT
POSTE INFERIOR DE LA CABECERA



G x4
34261

EXTENSION POST
SUPPORT D'EXTENSION
POSTE DE EXTENSION

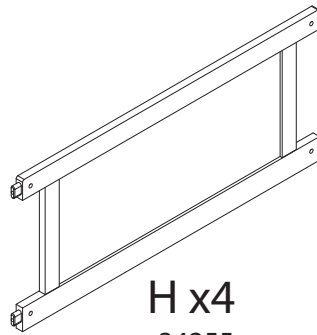

H x4
34255

HEADBOARD PANEL
PANNEAU TÊTE DE LIT
PANEL DE LA CABECERA

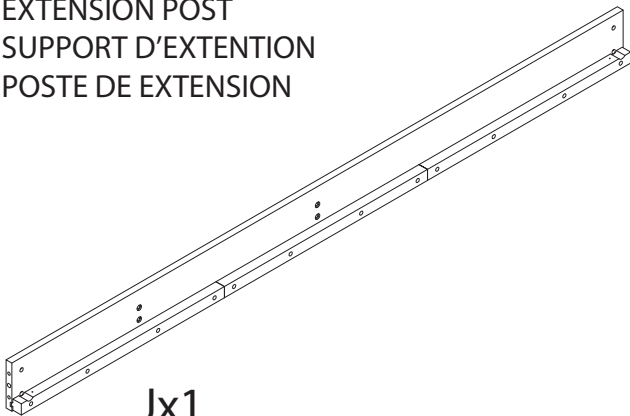

J x1
34262

TOP SIDE RAIL (FRONT)
RAIL SUPÉRIEUR LATÉRAL (AVANT)
RIEL LATERAL SUPERIOR (FRONTAL)

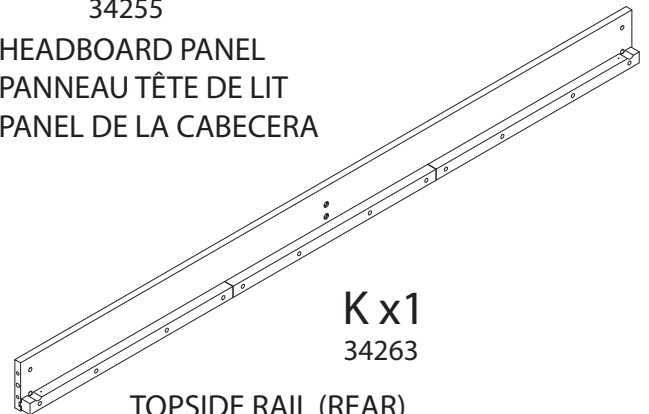

K x1
34263

TOPSIDE RAIL (REAR)
RAIL SUPÉRIEUR LATÉRAL (ARRIÈRE)
RIEL LATERAL SUPERIOR (TRASERO)

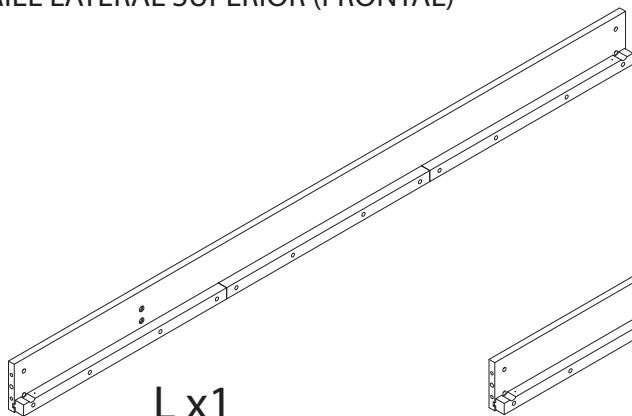

L x1
34264

BOTTOM SIDE RAIL (FRONT)
RIEL LATERAL INFERIOR (FRONTAL)
RAIL INFÉRIEUR LATÉRAL (AVANT)

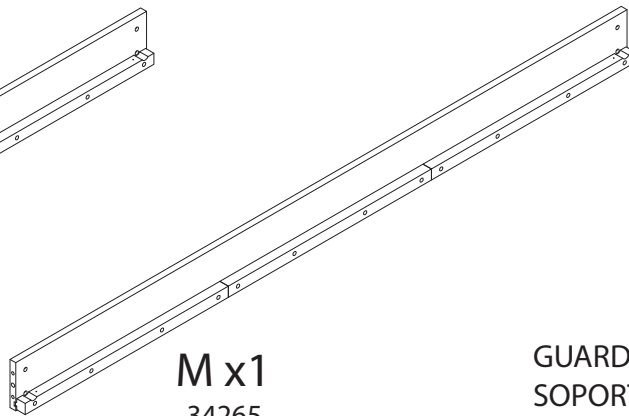

M x1
34265

BOTTOM SIDE RAIL (REAR)
RIEL LATERAL INFERIOR (TRASERO)
RAIL INFÉRIEUR LATÉRAL (ARRIÈRE)



N x2
34266

GUARD RAIL SUPPORT
SOPORTE DE LA BARANDILLA
SUPPORT DE LA BARRIÈRE



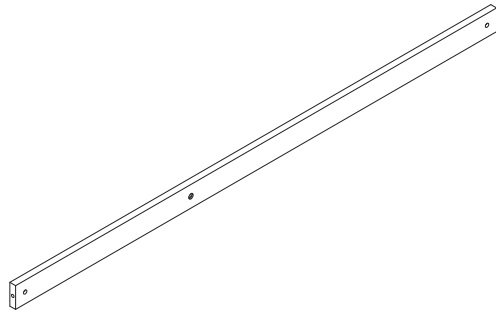

P x2
34267

SEMI GUARD RAIL
BARRIÈRE COURTE
SEMI-RIEL DE LA BARANDILLA

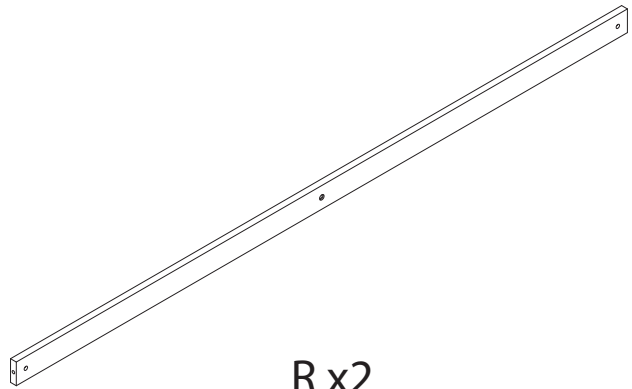

R x2
34268

FULL GUARD RAIL
BARRIÈRE LONGUE
RIEL LARGO DE LA BARANDILLA



S x1
34269

LADDER LEFT SIDE
CÔTÉ GAUCHE DE L'ECHELLE
LADO IZQUIERO DE LA ESCALERA



T x1
34270

LADDER RIGHT SIDE
CÔTÉ DROIT DE L'ECHELLE
LADO DERECHO DE LA ESCALERA



Y x4
34271

LADDER SLAT
LATTE D'ECHELLE
LISTON DE LA ESCALERA

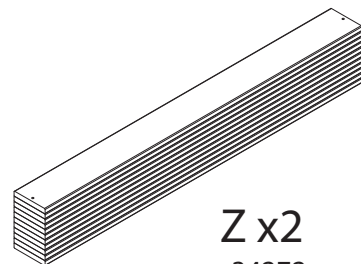

Z x2
34272

WOODEN SLAT
LATTE EN BOIS
LISTON DE MADERA



STEP 1
ÉTAPE 1
PASO 1

Note: Wood Dowel are shown full size
Remarque : Les chevilles en bois sont montrées à leur taille réelle
Nota: EL tarugo de madera se muestra en tamaño real.

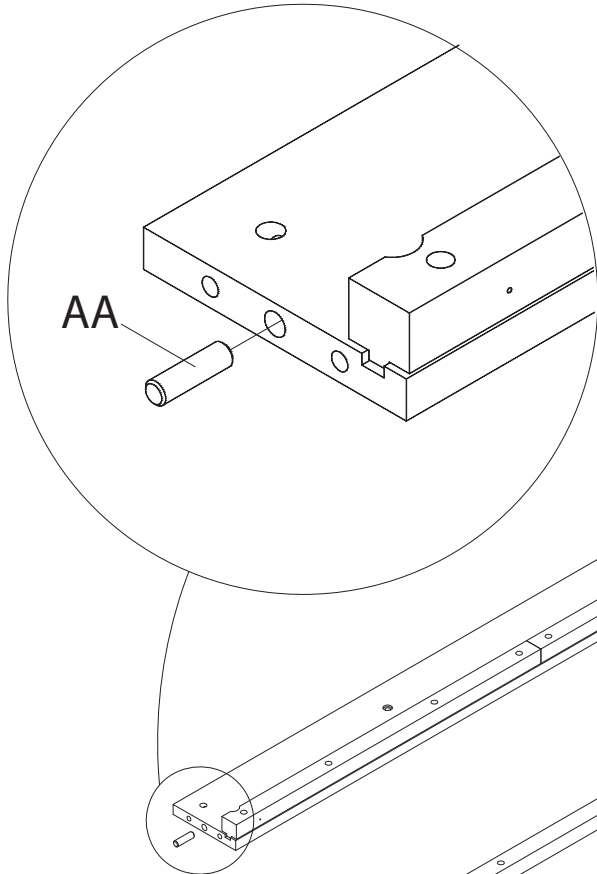
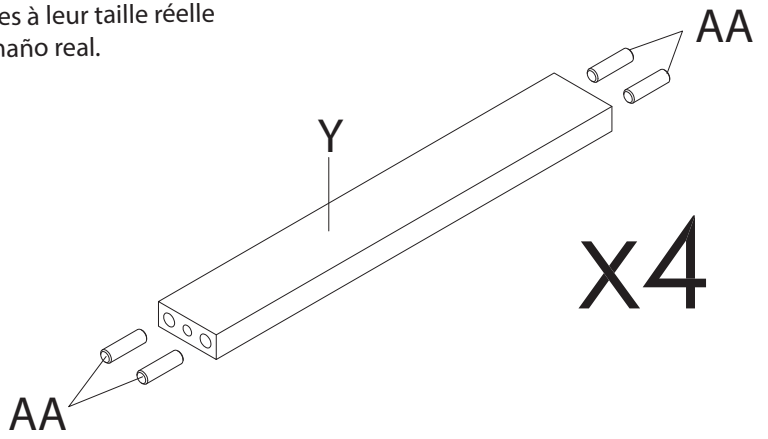
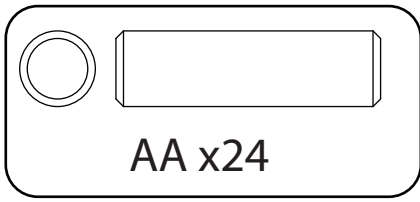

x8

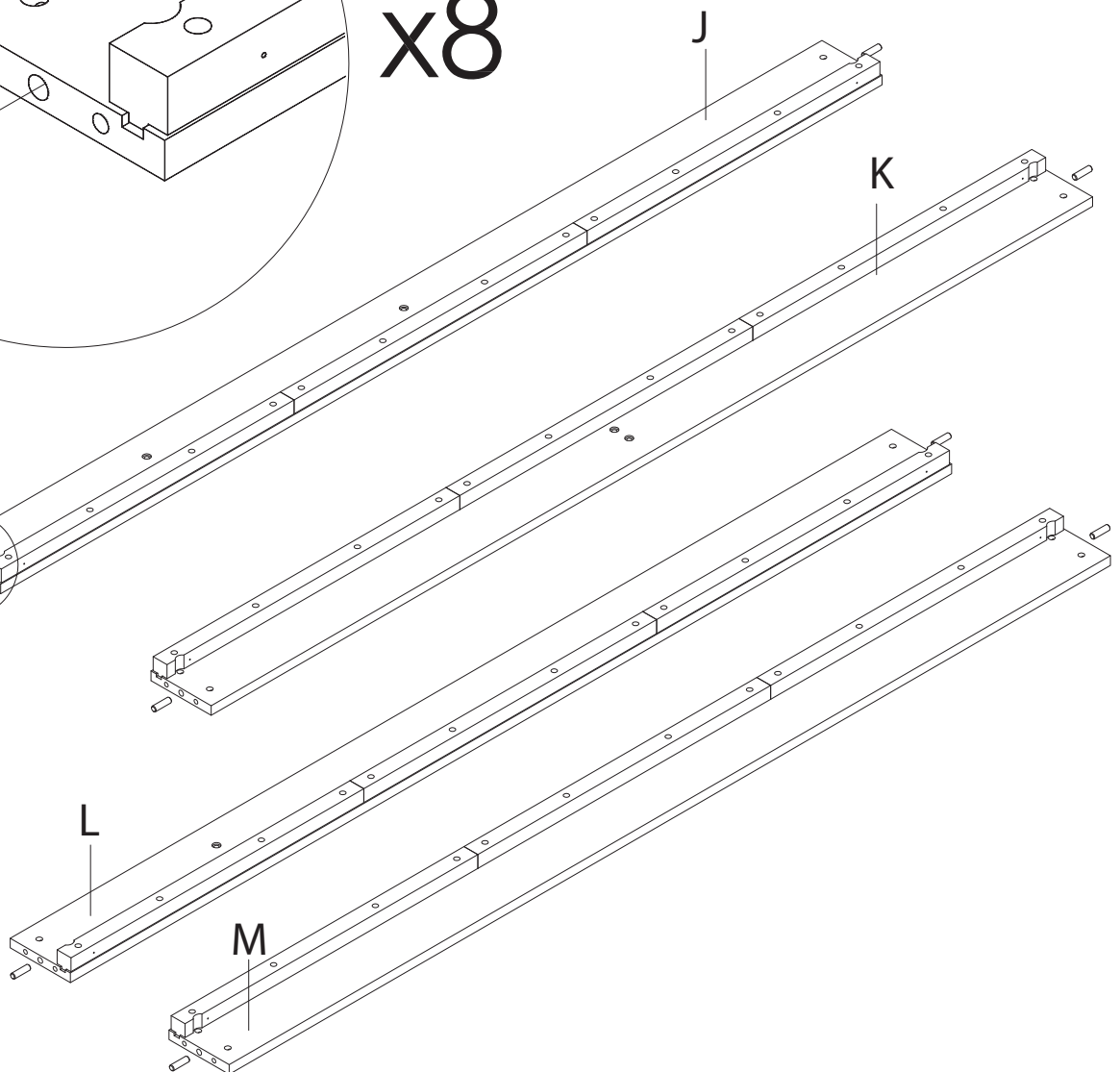

Insert (AA) into holes on Top Side Rail (Front), Top Side Rail (Rear), Bottom Side Rail (Front), Bottom Side Rail (Rear) and Ladder Slat.

Insérez (AA) dans les orifices sur le rail supérieur latéral (Avant), le rail supérieur latéral (Arrière), rail inférieur latéral (Avant) rail inférieur latéral (Arrière) et la latte de l'échelle.

Insertar (AA) en los agujeros del riel lateral superior (frontal), riel lateral superior (trasero), riel lateral inferior (frontal), riel lateral inferior (trasero) y el listón de la escalera.



STEP 2
ÉTAPE 2
PASO 2

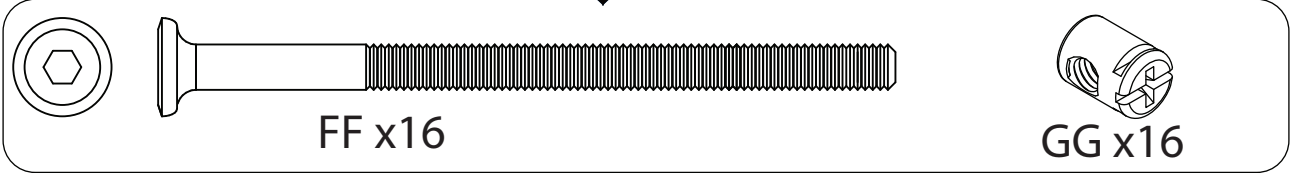

Note: Fasteners are shown full size
Remarque : les attaches sont montrées à leur taille réelle
Nota: Los sujetadores se muestran de tamaño real

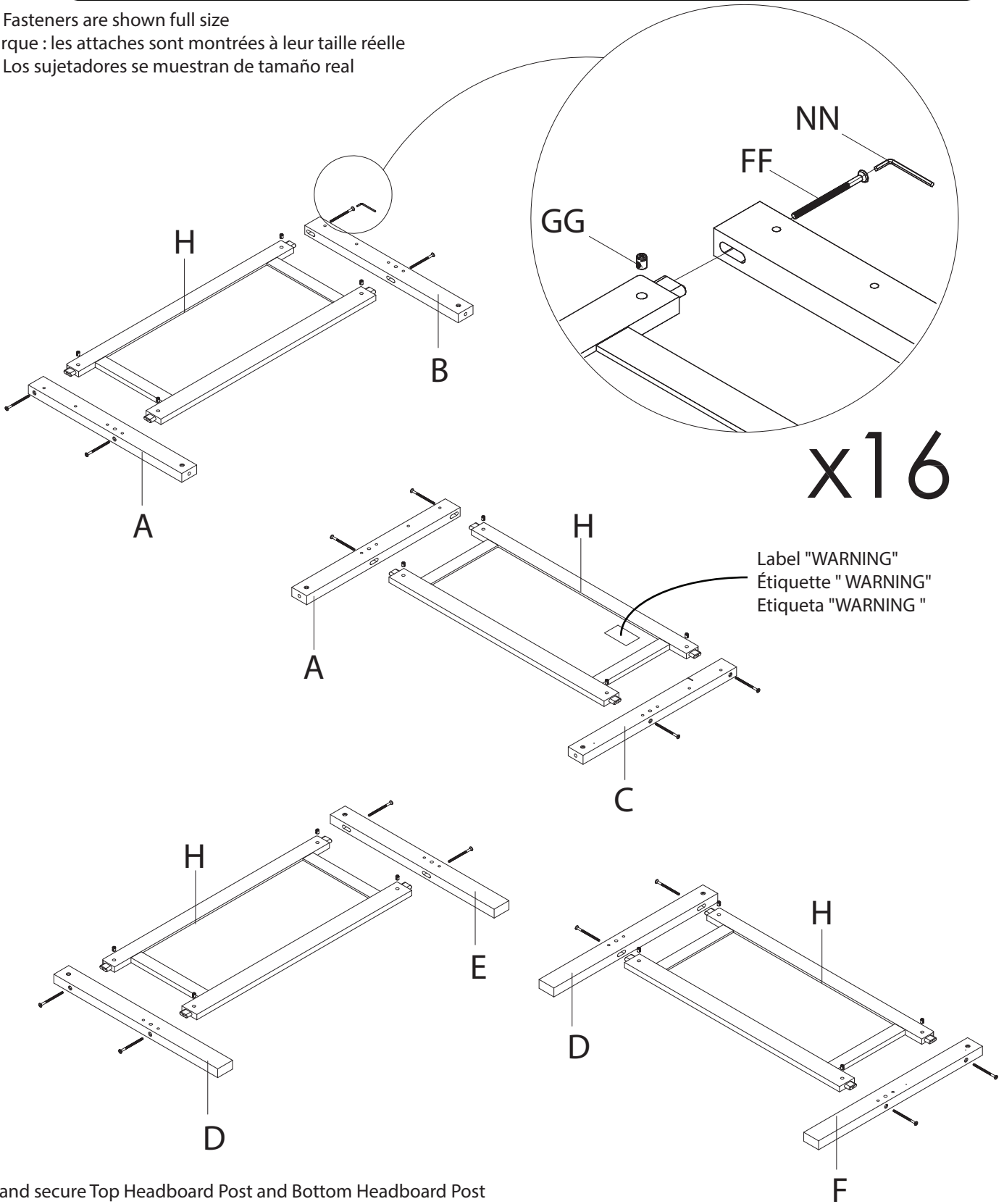

Attach and secure Top Headboard Post and Bottom Headboard Post onto Headboard Panel by using (FF) and (GG), tighten it up by using (NN).

Fixez et sécurisez le support supérieur de tête de lit et le support inférieur de tête de lit au panneau de tête de lit en utilisant (FF) et (GG), serrez en utilisant (NN)

Unir y asegurar los postes superior e inferior de la cabecera sobre el panel de la cabecera utilizando (FF) y (GG), apretarlo utilizando (NN).



STEP 3
ÉTAPE 3
PASO 3

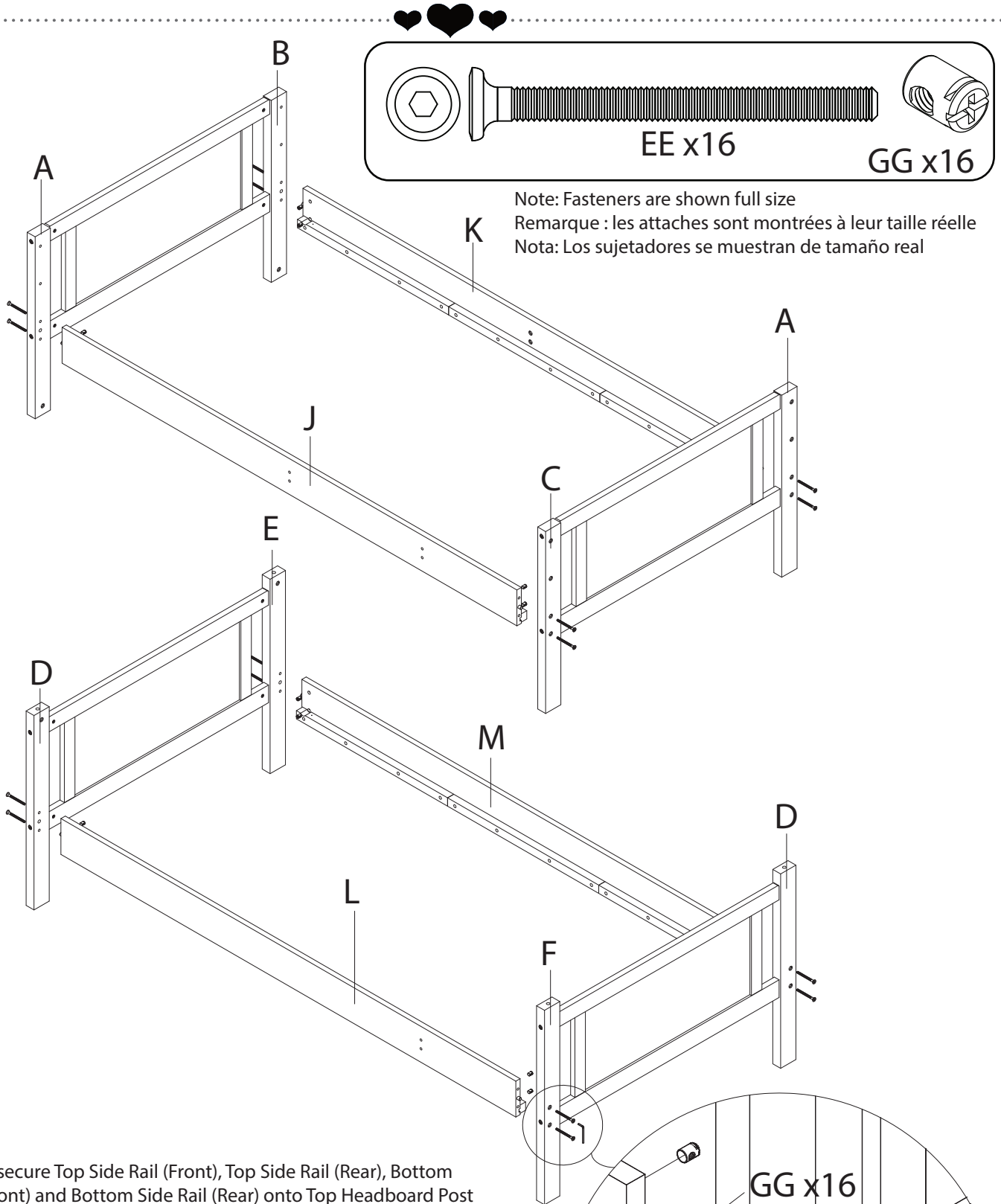

Attach and secure Top Side Rail (Front), Top Side Rail (Rear), Bottom Side Rail (Front) and Bottom Side Rail (Rear) onto Top Headboard Post and Bottom Headboard Post by using (EE) and (GG), tighten it up by using (NN).

Fixez et sécurisez le rail supérieur latéral (Avant), la rail supérieur latéral (Arrière), le rail inférieur latéral (Avant) et le rail inférieur latéral (Arrière) au support supérieur de tête de lit et le support inférieur de tête de lit en utilisant (EE) et (GG), serrez en utilisant (NN)

Unir y asegurar el riel lateral superior (frontal), el riel lateral superior (trasero), el riel lateral inferior (frontal) y el riel lateral inferior (trasero) sobre el poste superior de la cabecera utilizando (EE) y (GG), apretarlo utilizando (NN).

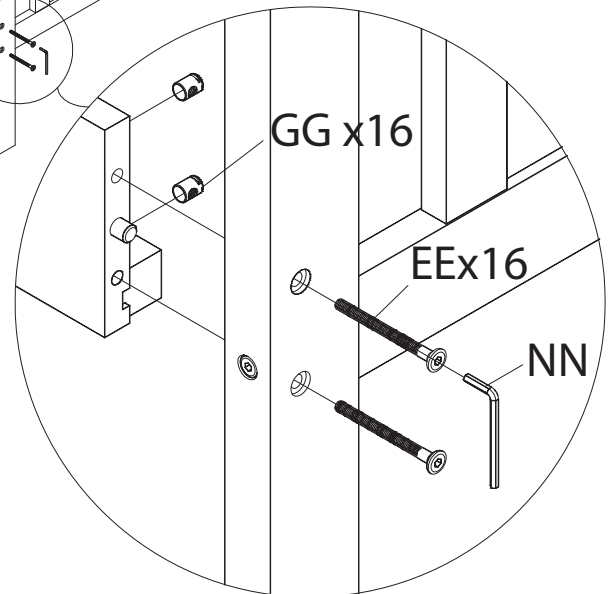



STEP 4 Note: Fasteners are shown full size
 ÉTAPE 4 Remarque : les attaches sont montrées à leur taille réelle
 PASO 4 Nota: Los sujetadores se muestran de tamaño real

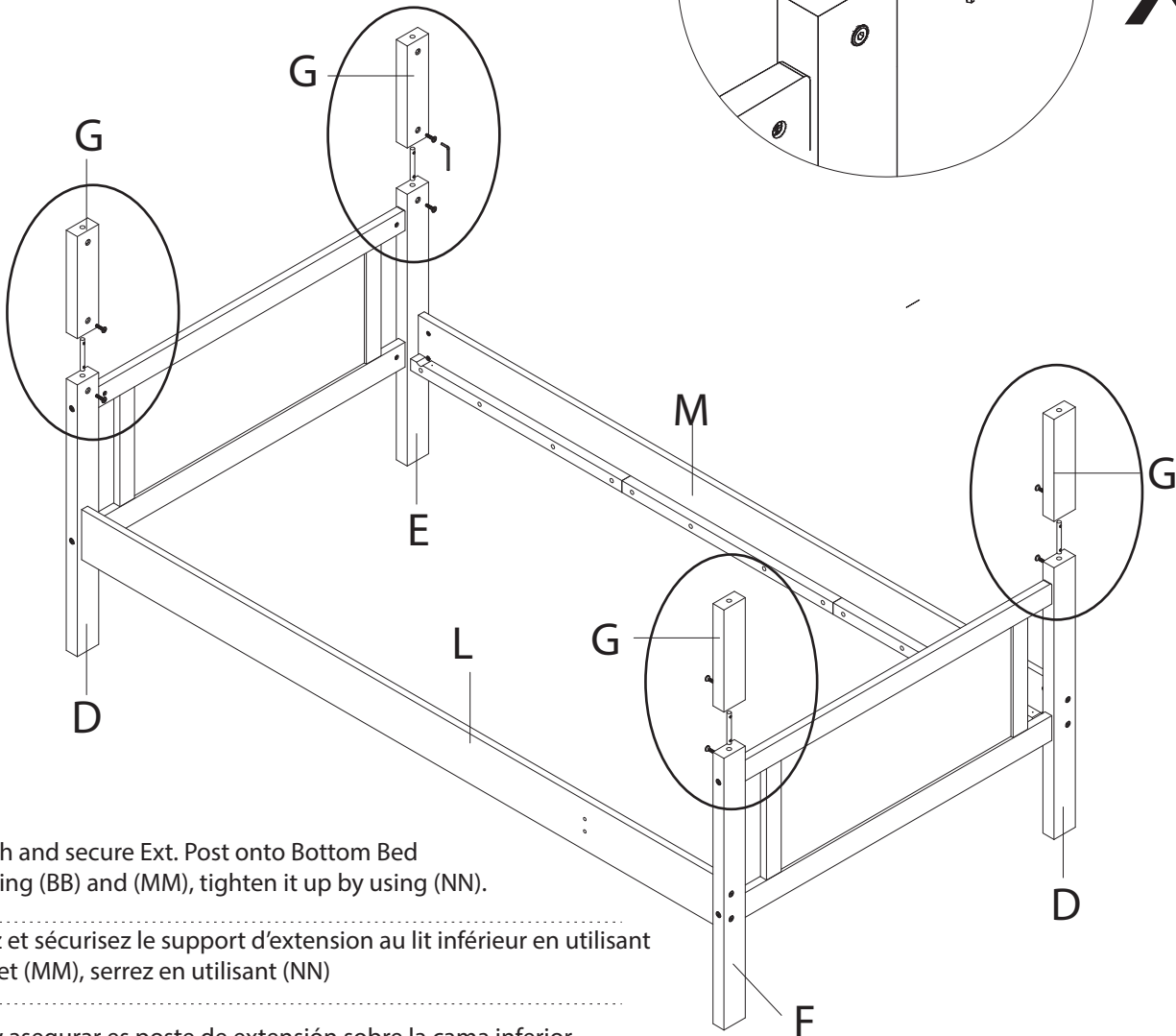
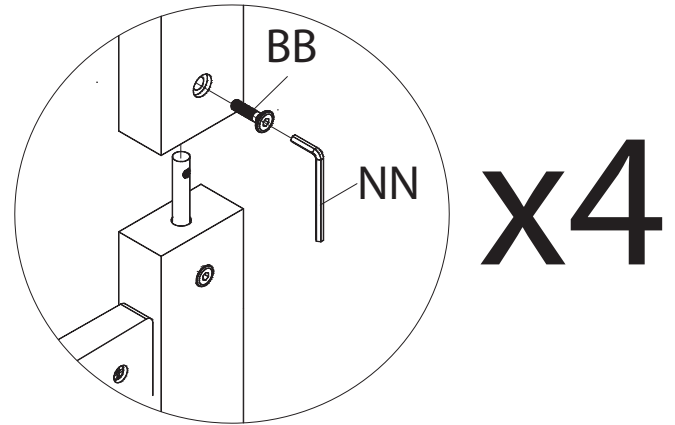
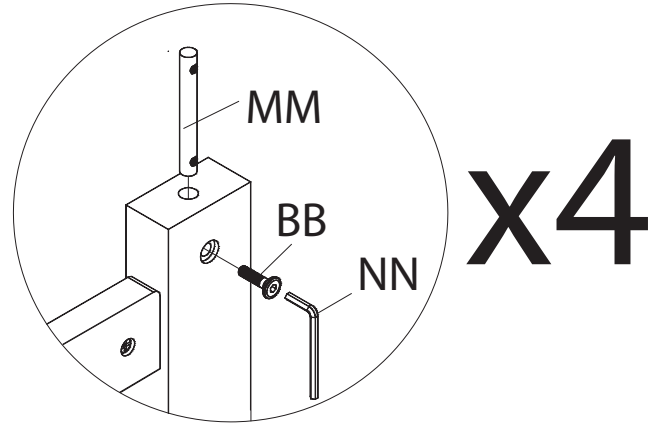
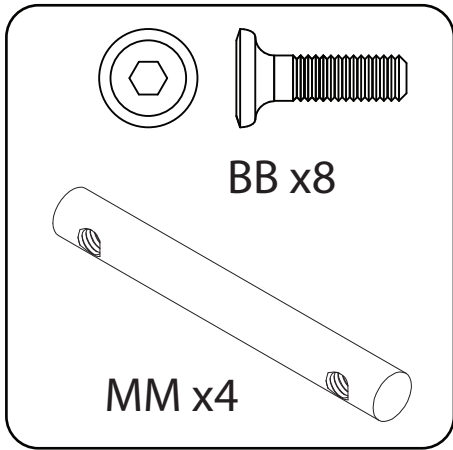

Attach and secure Ext. Post onto Bottom Bed by using (BB) and (MM), tighten it up by using (NN).

Fixez et sécurisez le support d'extension au lit inférieur en utilisant (BB) et (MM), serrez en utilisant (NN)

Unir y asegurar es poste de extensión sobre la cama inferior utilizando (BB) y (MM) apretar utilizando (NN).





STEP 5
ÉTAPE 5
PASO 5

Note: Fasteners are shown full size
Remarque : les attaches sont montrées à leur taille réelle
Nota: Los sujetadores se muestran de tamaño real

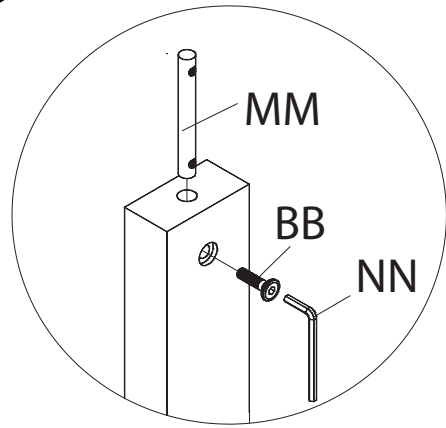
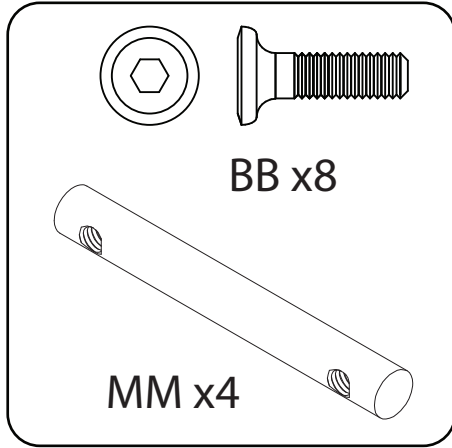

x4

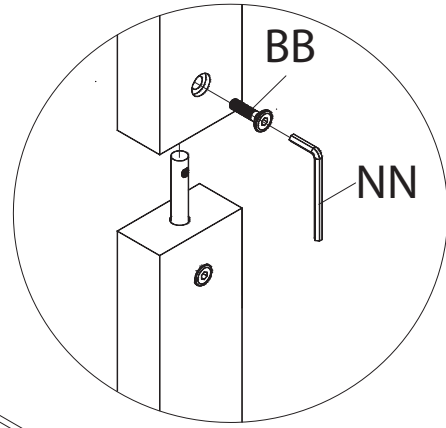

x4

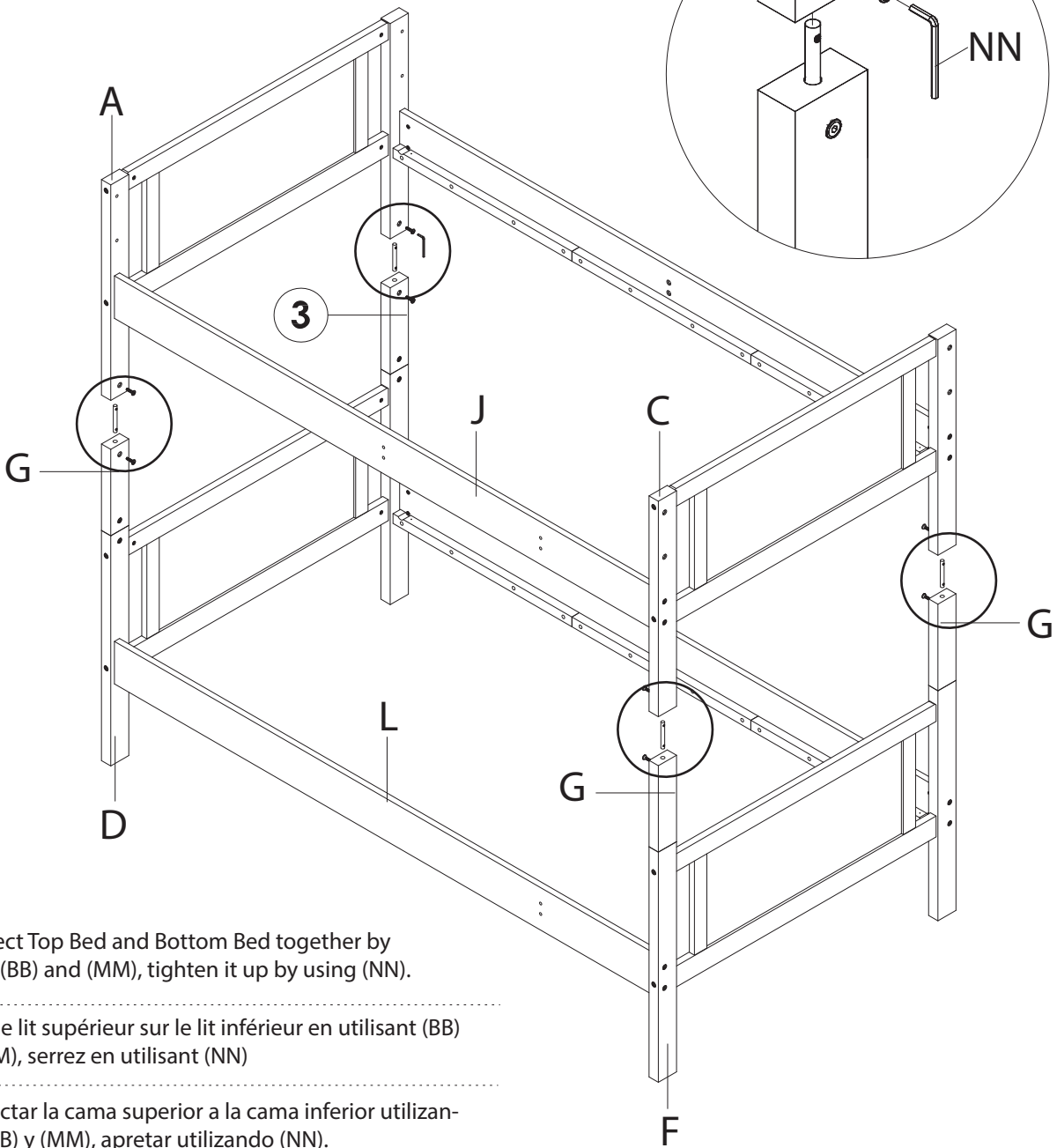

Connect Top Bed and Bottom Bed together by using (BB) and (MM), tighten it up by using (NN).

Fixez le lit supérieur sur le lit inférieur en utilisant (BB) et (MM), serrez en utilisant (NN)

Conectar la cama superior a la cama inferior utilizando (BB) y (MM), apretar utilizando (NN).





STEP 6
ÉTAPE 6
PASO 6

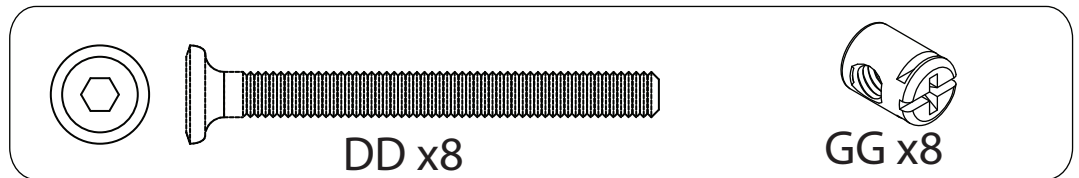

Note: Fasteners are shown full size
Remarque : les attaches sont montrées à leur taille réelle
Nota: Los sujetadores se muestran de tamaño real

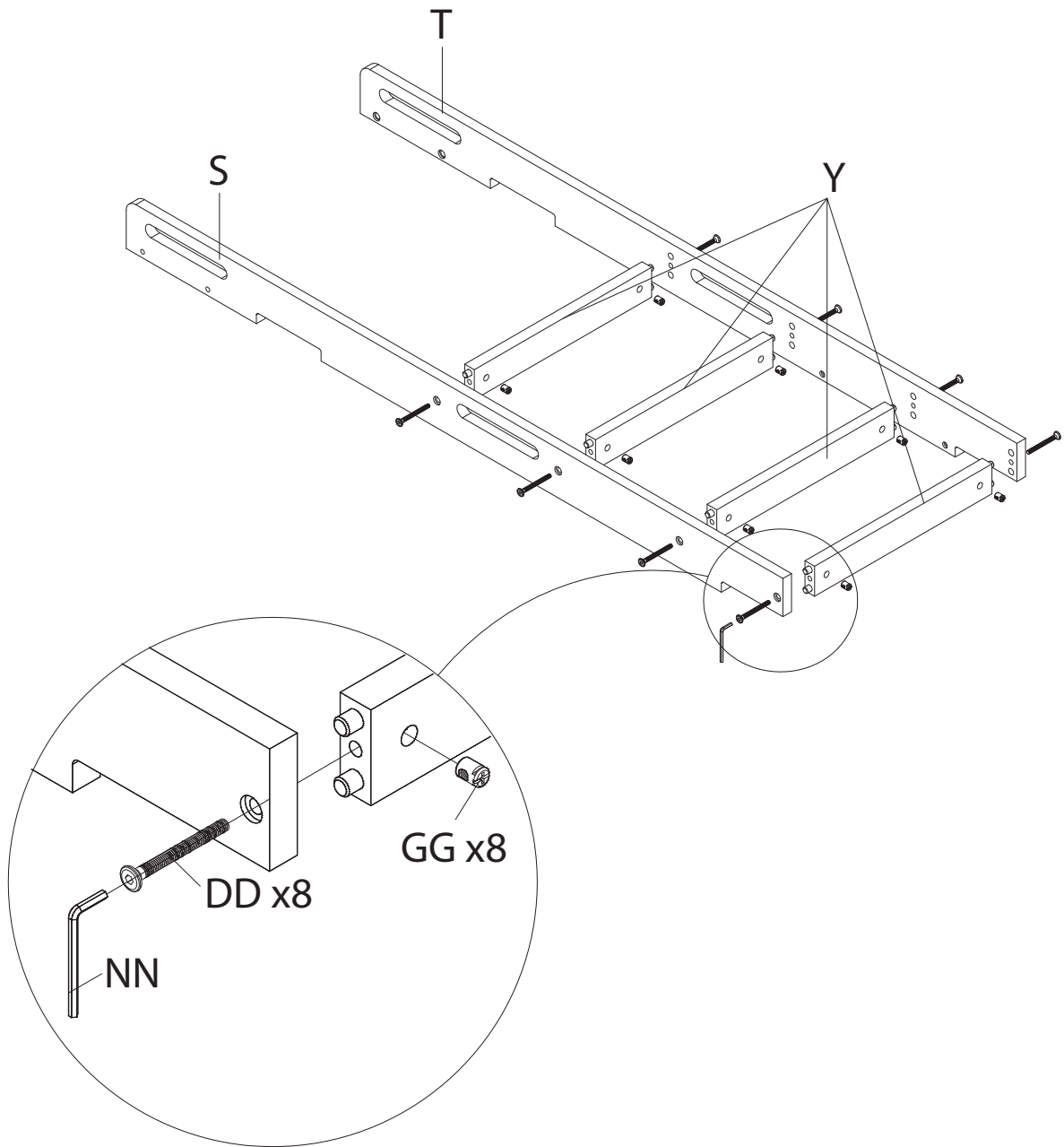

Attach and secure Ladder Side (L/R) onto Ladder Slat by using (DD) and (GG), tighten it up by using (NN).

Fixez et sécurisez le côté de l'échelle (L/R) à la latte de l'échelle en utilisant (DD) et (GG), serrez en utilisant (NN).

Unir y asegurar los lados de la escalera (L/D) con los listones de la escalera utilizando (DD) y (GG), apretar utilizando (NN).



STEP 7
ÉTAPE 7
PASO 7

Note: Fasteners are shown full size
Remarque : les attaches sont montrées à leur taille réelle
Nota: Los sujetadores se muestran de tamaño real

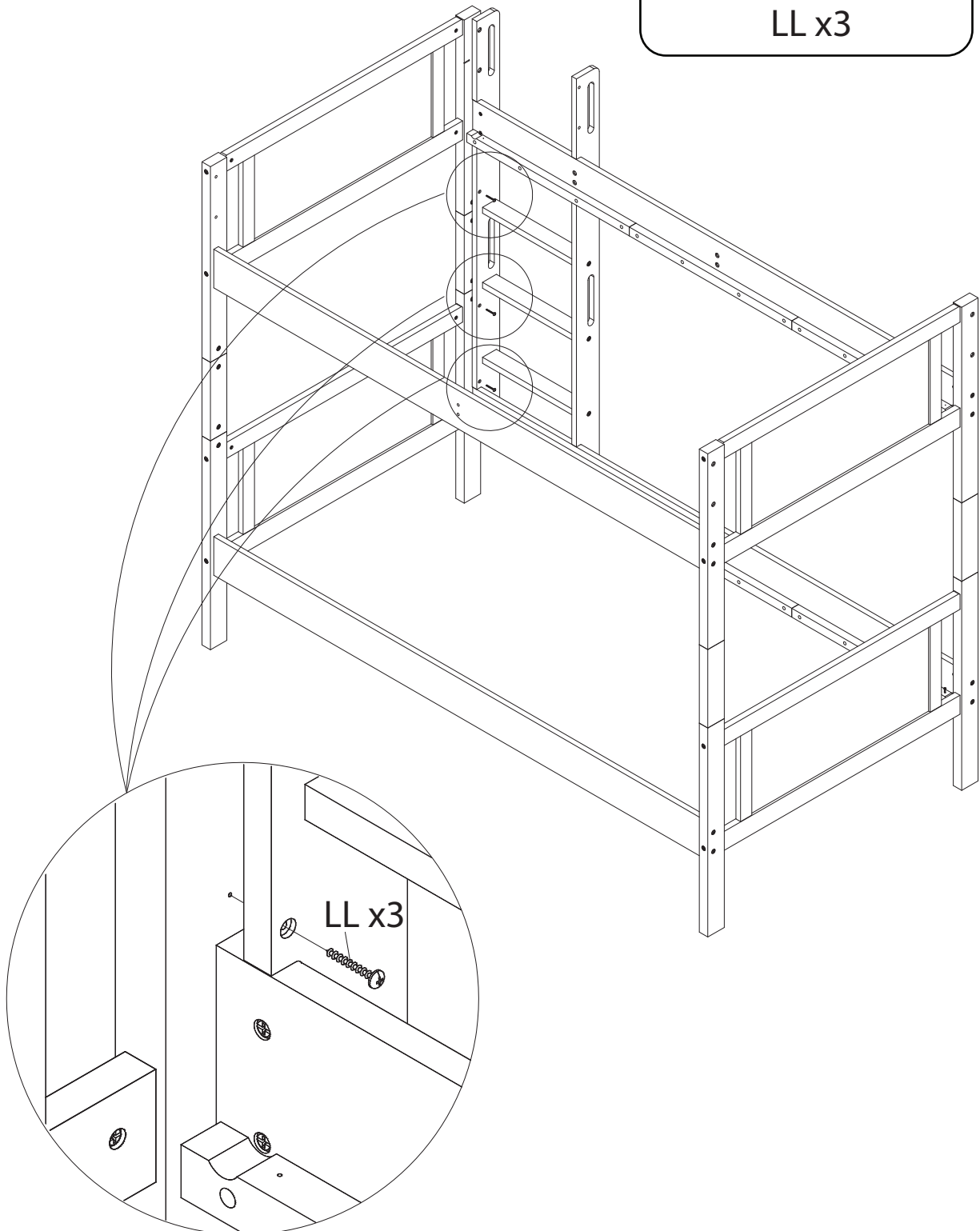
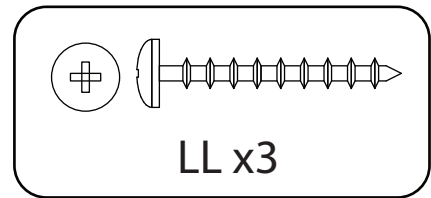

Attach and secure Ladder onto the Top Headboard Post, Bottom Headboard Post, Top Side Rail (Front) and Bottom Side Rail (Front), Follow it up by Screw (LL) onto Ladder Side (T).

Fixez et sécurisez l'échelle au support supérieur de la tête de lit, le support inférieur de la tête de lit, le rail supérieur latéral (Avant) et le rail inférieur latéral (Avant), vissez (LL) sur le côté de l'échelle (T).

Unir y asegurar la escalera sobre el poste superior de la cabecera, el poste inferior de la cabecera, el riel lateral superior (frontal) y el riel lateral inferior (frontal), atornillar (LL) en el lado de la escalera (T).



STEP 8
ÉTAPE 8
PASO 8

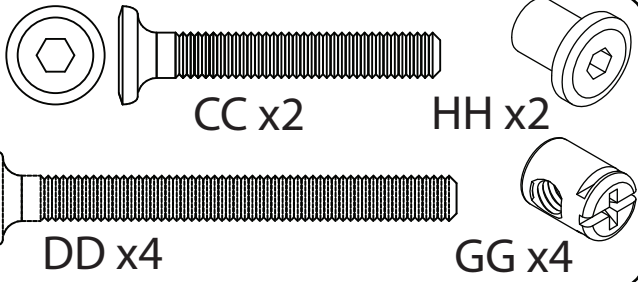

Note: Fasteners are shown full size
Remarque : les attaches sont montrées à leur taille réelle
Nota: Los sujetadores se muestran de tamaño real

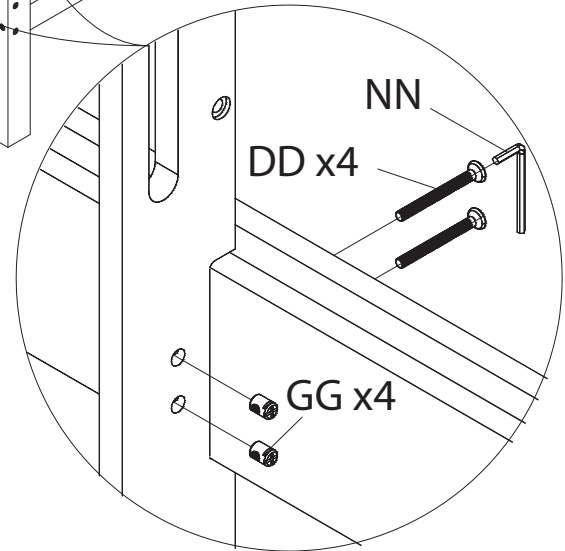
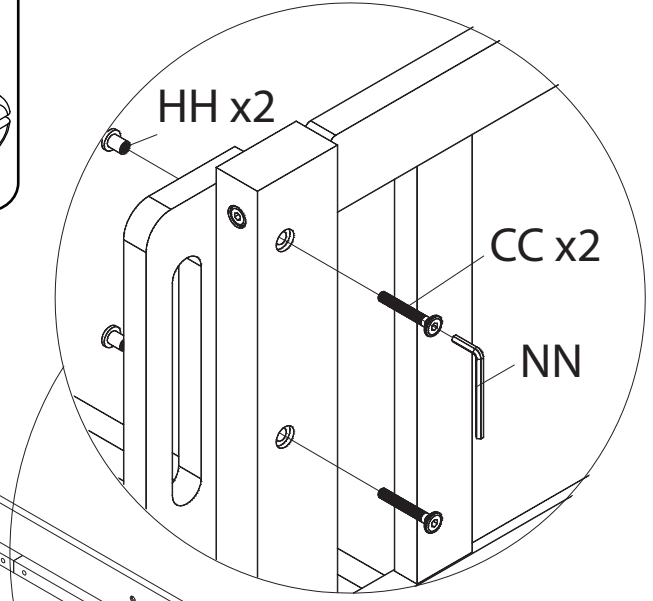
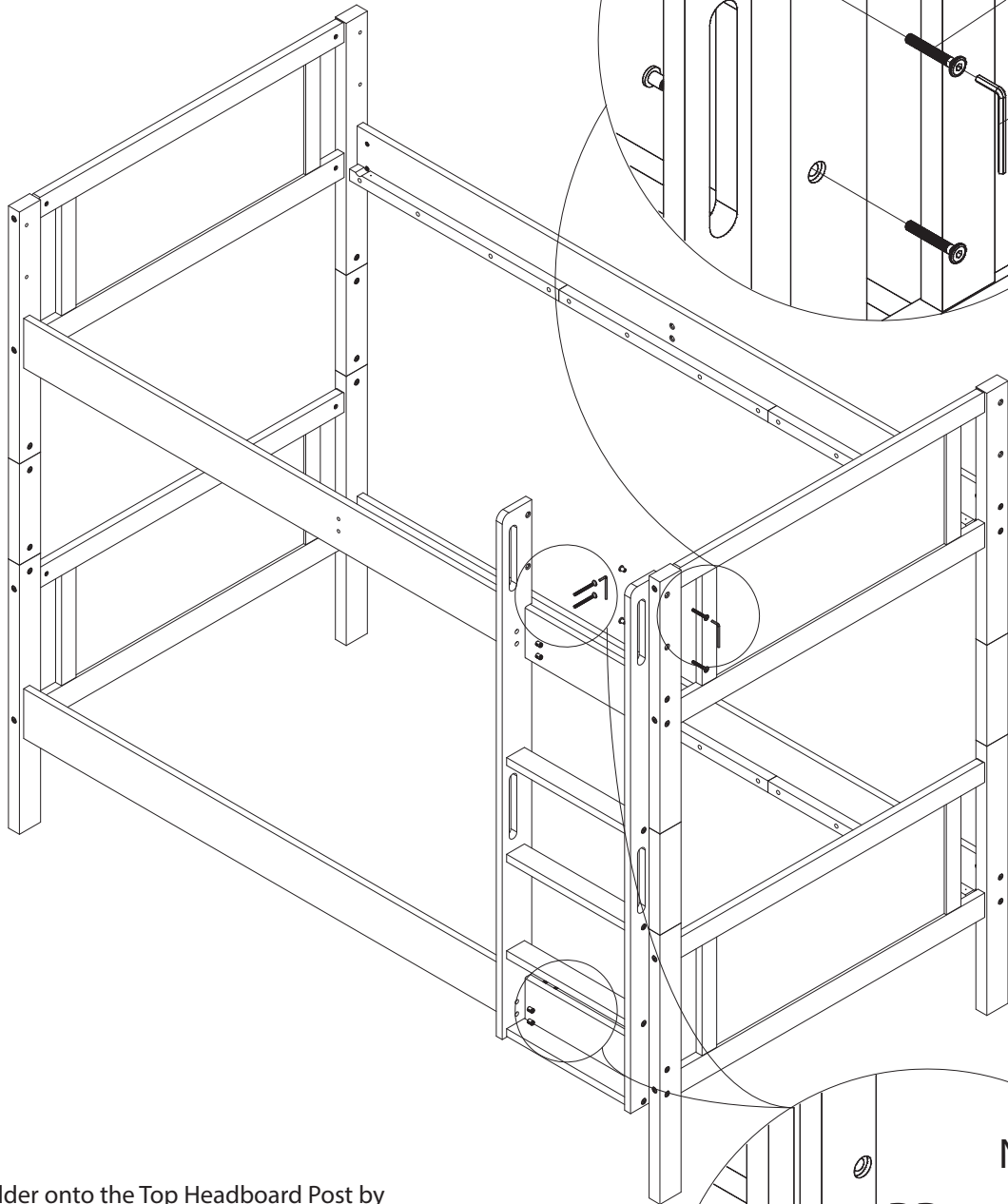

Attach and secure Ladder onto the Top Headboard Post by using (CC) and (HH), Ladder to Top Side Rail (Front) and Bottom Side Rail (Front) by using (DD) and (GG), tighten it up by using (NN).

Fixez et sécurisez l'échelle au support supérieur de la tête de lit en utilisant (CC) et (HH), l'échelle au rail supérieur latéral (Avant) et le rail inférieur latéral (Avant) et utilisant (DD) et (GG), serrez en utilisant (NN).

Unir y asegurar la escalera con el poste superior de la cabecera utilizando (CC) y (HH), la escalera al riel lateral superior (frontal) y el riel lateral inferior (frontal) utilizando (DD) y (GG), apretar utilizando (NN).





STEP 9
ÉTAPE 9
PASO 9

Note: Fasteners are shown full size
Remarque : les attaches sont montrées à leur taille réelle
Nota: Los sujetadores se muestran de tamaño real

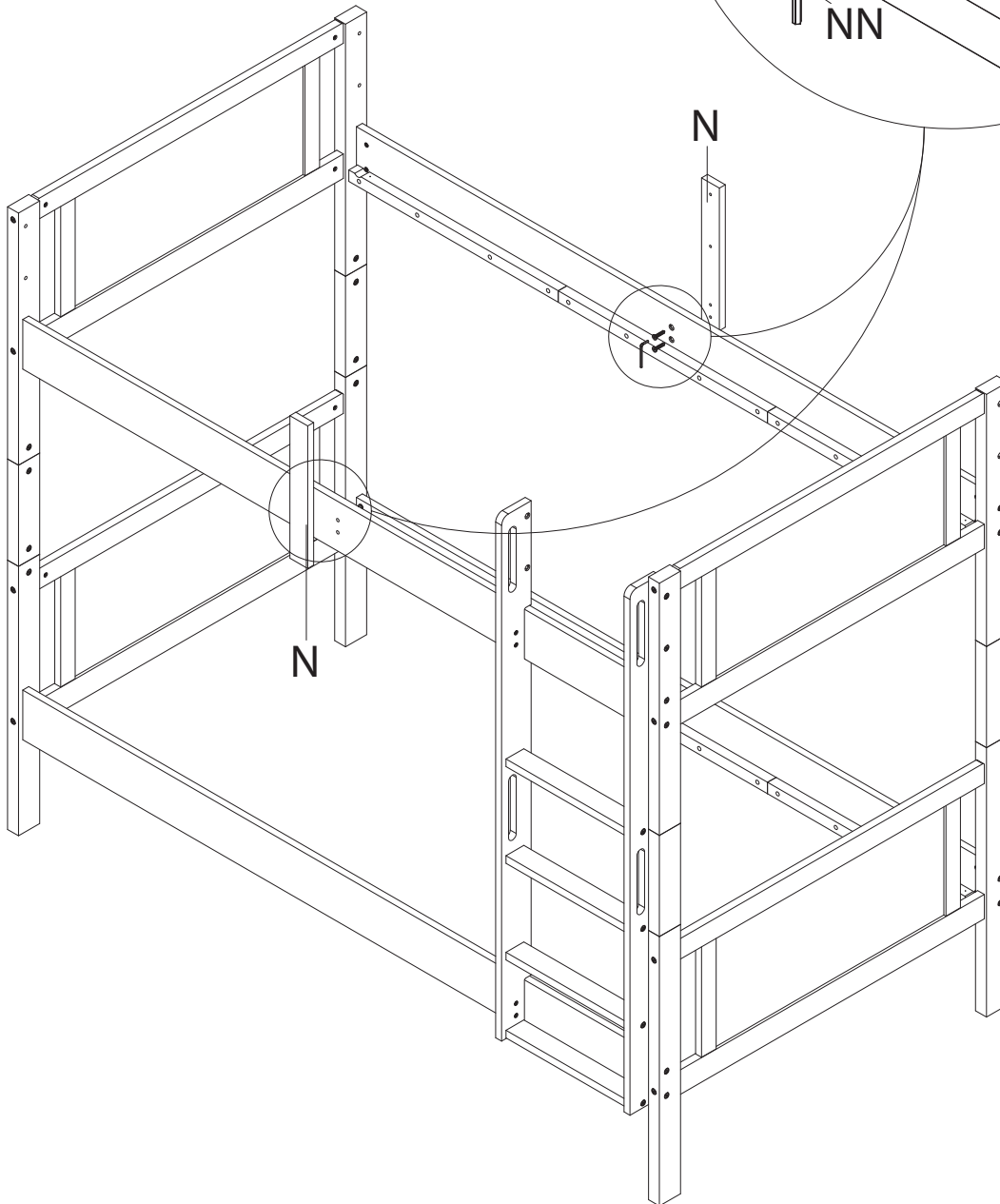
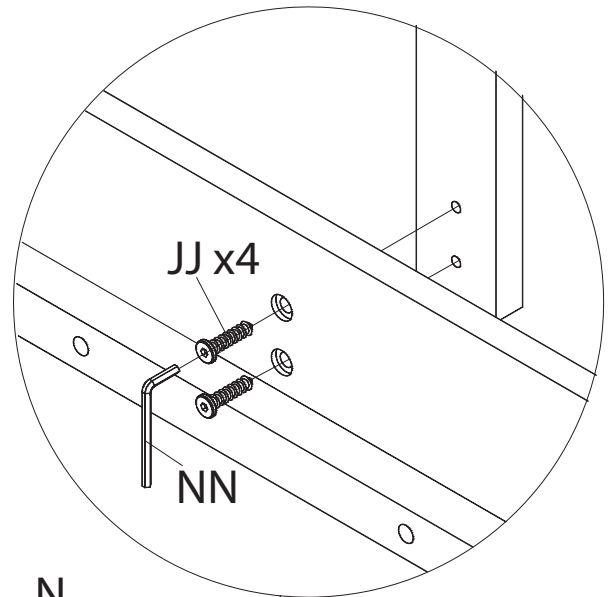
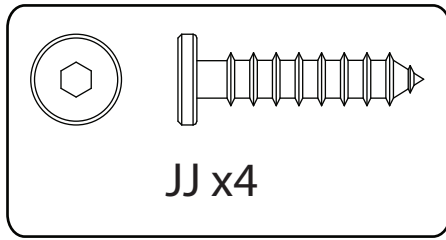

Attach and secure Guard Rail Support onto Top Side Rail (Front) and Top Side Rail (Rear) by using (JJ), tighten it up by using (NN).

Fixez et sécurisez le support de barrière au rail supérieur latéral (Avant) et le rail supérieur latéral (Arrière) en utilisant (JJ), serrez en utilisant (NN).

Unir y asegurar el soporte de la barandilla con el riel lateral superior (frontal) y el riel lateral superior (trasero) utilizando (JJ), apretar utilizando (NN).



STEP 10
ÉTAPE 10
PASO 10

Note: Fasteners are shown full size
Remarque : les attaches sont montrées à leur taille réelle
Nota: Los sujetadores se muestran de tamaño real

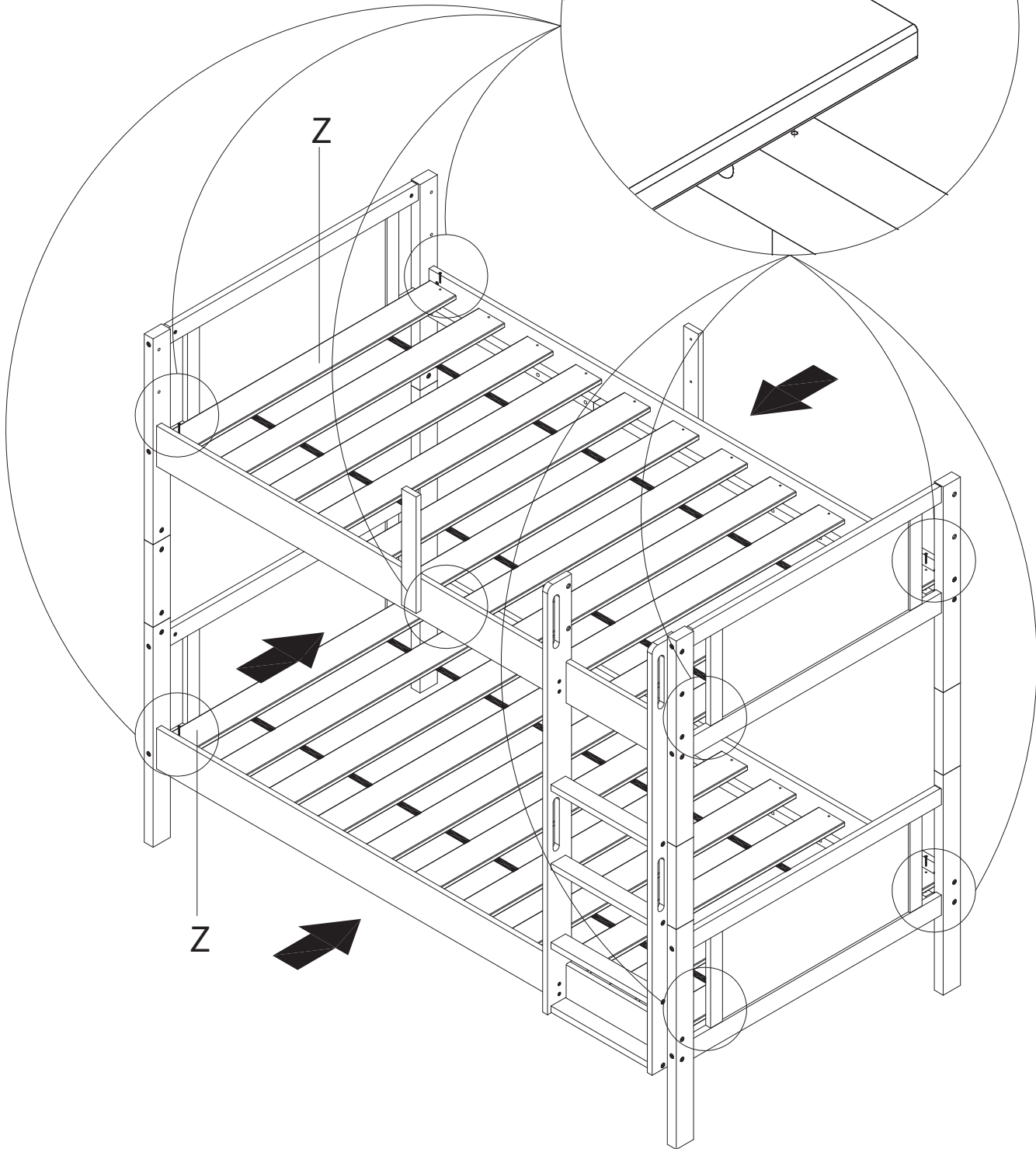
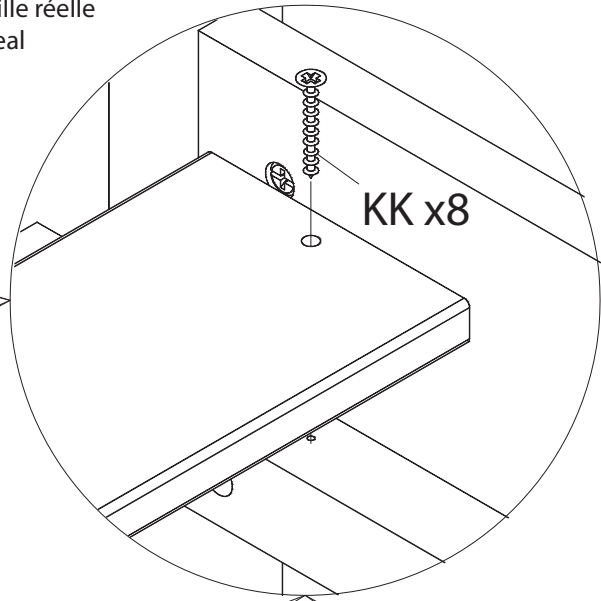
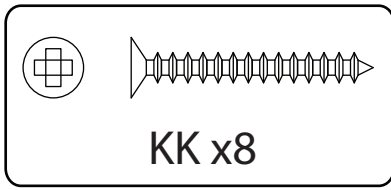

Attach and secure Wooden Slat onto both Side Rail by using (KK), tighten it up by using a Crosshead Screwdriver.
Align both Side Rail before tightening the screws.

Fixez et sécurisez la latte en bois au deux rails latéraux en utilisant (KK), serrez en utilisant un tournevis cruciforme.
Alignez les deux rails latéraux avant de serrer les vis.

Unir y asegurar los listones de madera de la cama sobre ambos rieles laterales utilizando (KK), apretar utilizando un destornillador de cruz. Alinear ambos rieles laterales antes de apretar los tornillos.





STEP 11
ÉTAPE 11
PASO 11

Note: Fasteners are shown full size
Remarque : les attaches sont montrées à leur taille réelle
Nota: Los sujetadores se muestran de tamaño real

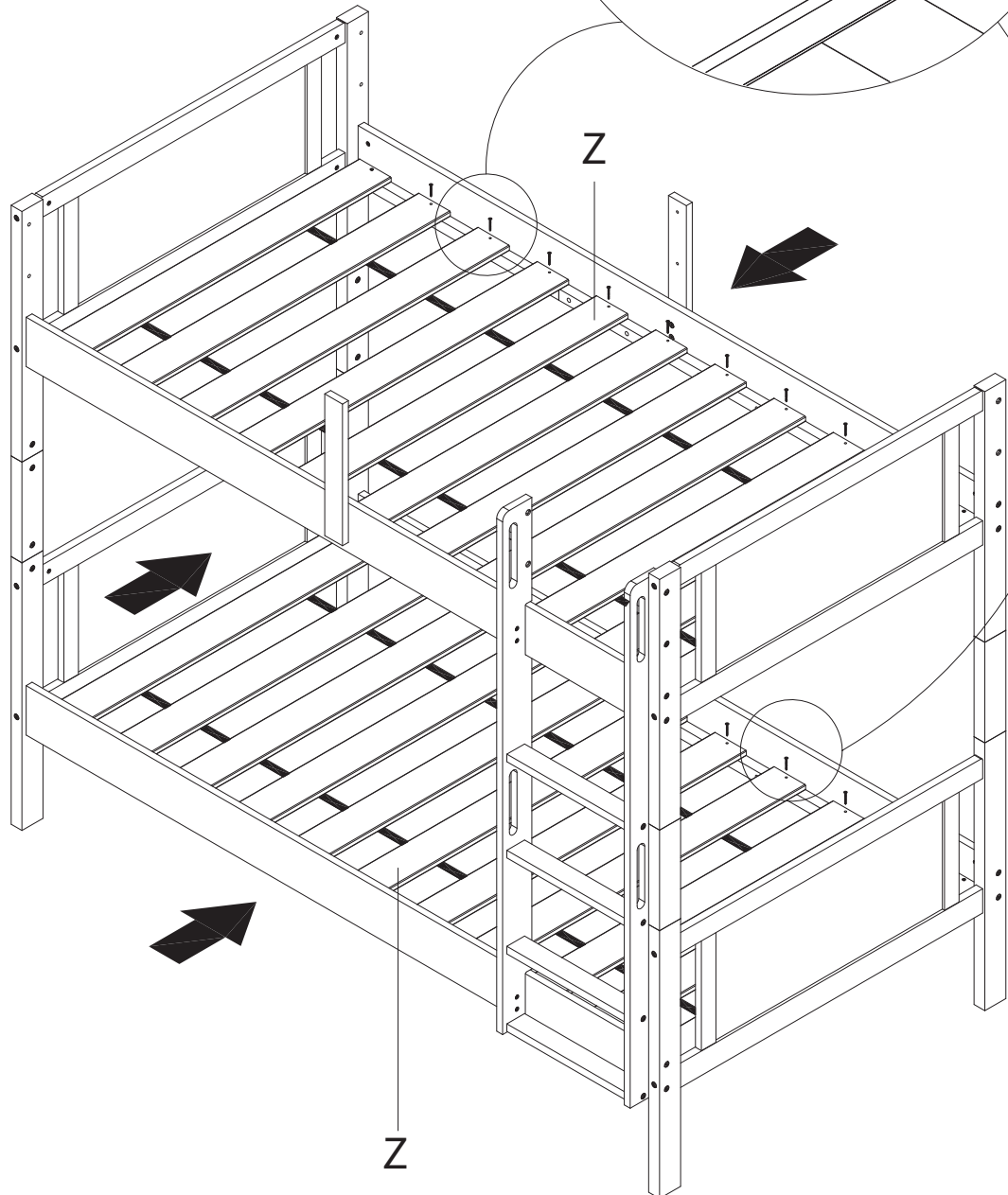
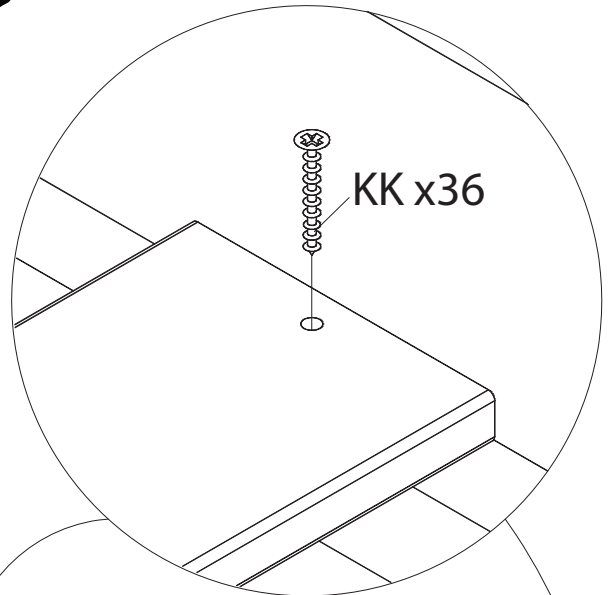
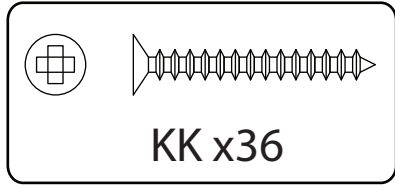

Attach and secure Wooden Slat onto both Side Rail by using (KK), tighten it up by using a Crosshead Screwdriver.
"Align both Side Rail before tightening the screws.

Fixez et sécurisez la latte en bois au deux rails latéraux en utilisant (KK), serrez en utilisant un tournevis cruciforme.
Alignez les deux rails latéraux avant de serrer les vis.

Unir y asegurar los listones de madera de la cama sobre ambos rieles laterales utilizando (KK), apretar utilizando un destornillador de cruz. Alinear ambos rieles laterales antes de apretar los tornillos.



STEP 12

ÉTAPE 12 Note: Fasteners are shown full size

PASO 12 Remarque : les attaches sont montrées à leur taille réelle
 Nota: Los sujetadores se muestran de tamaño real

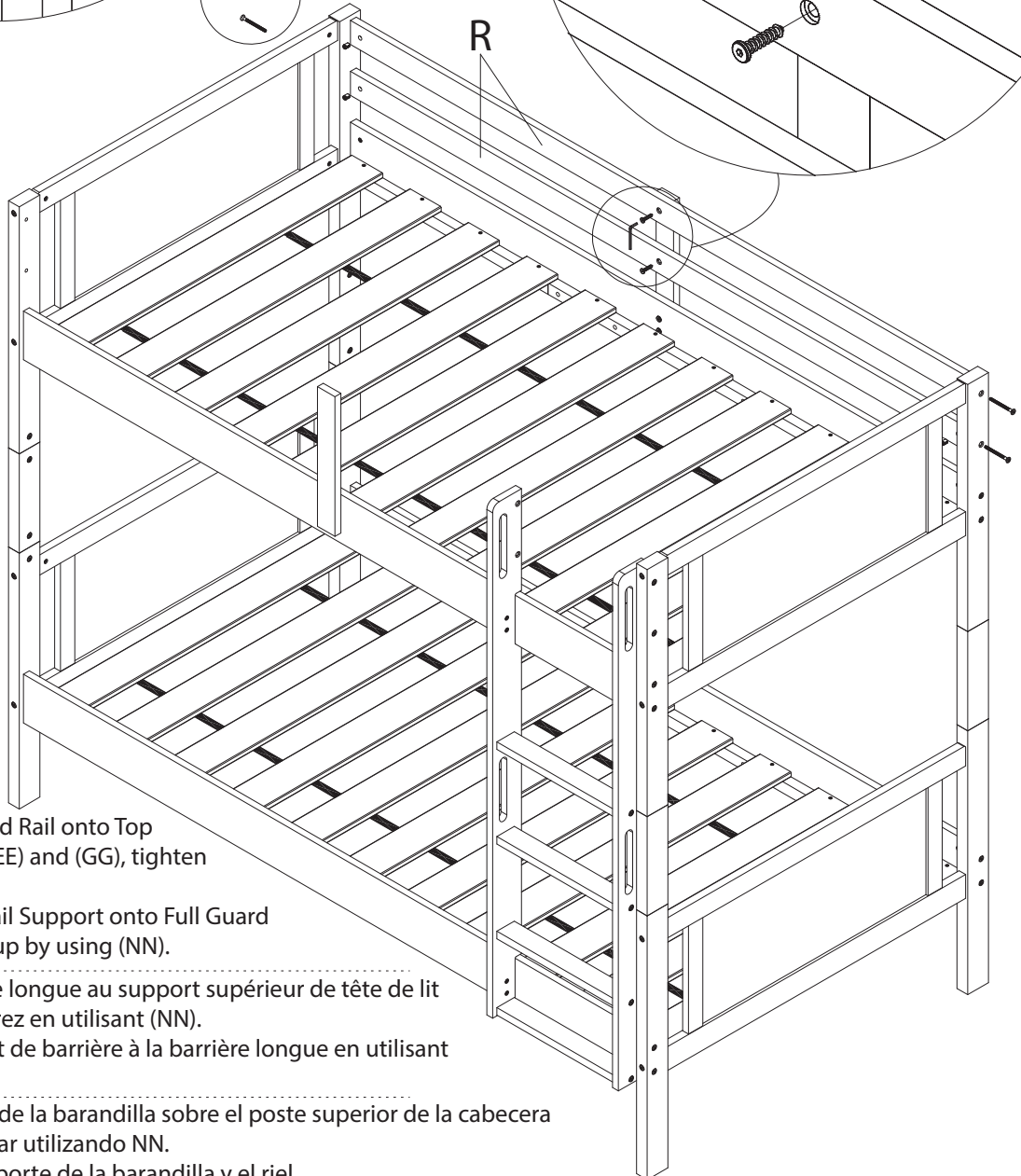
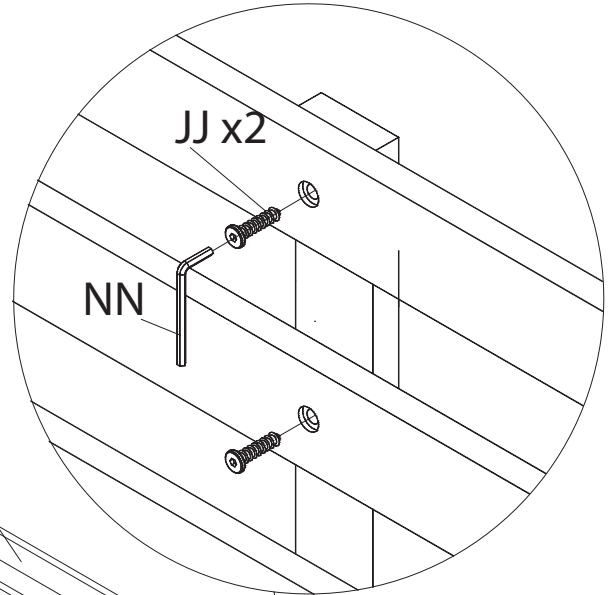
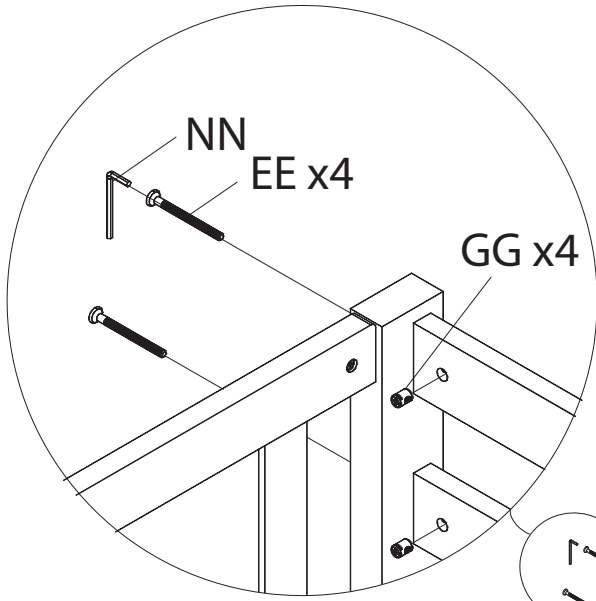
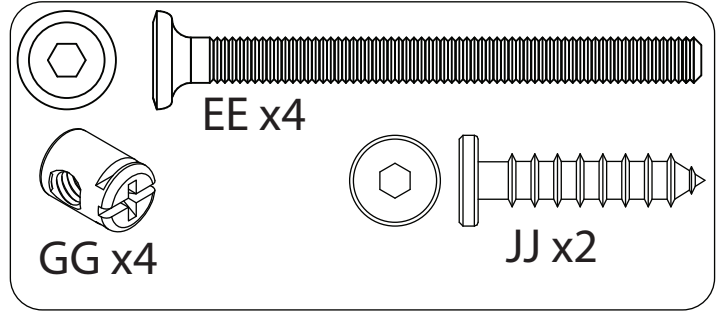

Attach and secure Full Guard Rail onto Top Headboard Post by using (EE) and (GG), tighten it up by using (NN).

Attach and secure Guard Rail Support onto Full Guard Rail by using (JJ), tighten it up by using (NN).

Fixez et sécurisez la barrière longue au support supérieur de tête de lit en utilisant (EE) et (GG), serrez en utilisant (NN).

Fixez et sécurisez le support de barrière à la barrière longue en utilisant (JJ), serrez en utilisant (NN).

Unir y asegurar el riel largo de la barandilla sobre el poste superior de la cabecera utilizando (EE) y (GG), apretar utilizando NN.

Unir y asegurar el riel de soporte de la barandilla y el riel largo de la barandilla utilizando (JJ), apretar utilizando (NN).





STEP 13
ÉTAPE 13
PASO 13

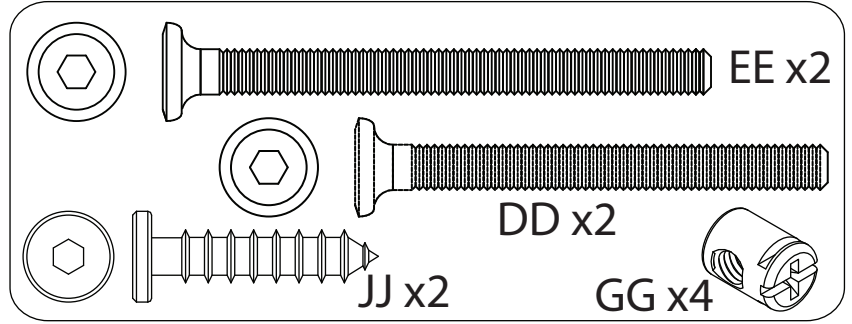
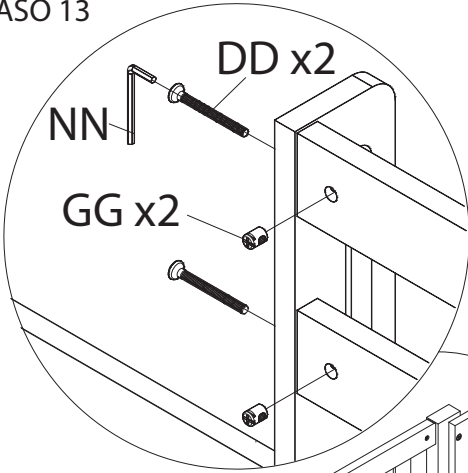

Note: Fasteners are shown full size
Remarque : les attaches sont montrées à leur taille réelle
Nota: Los sujetadores se muestran de tamaño real

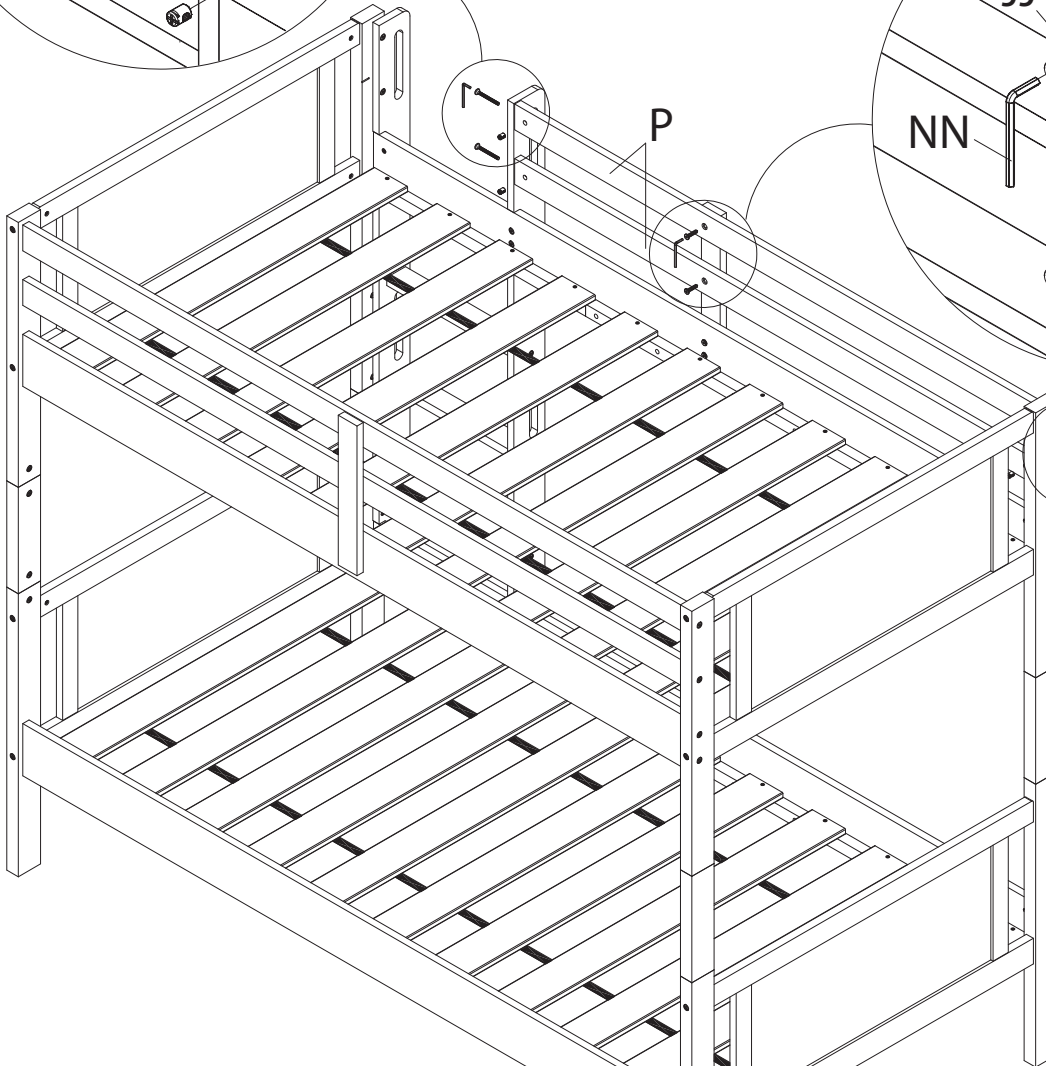
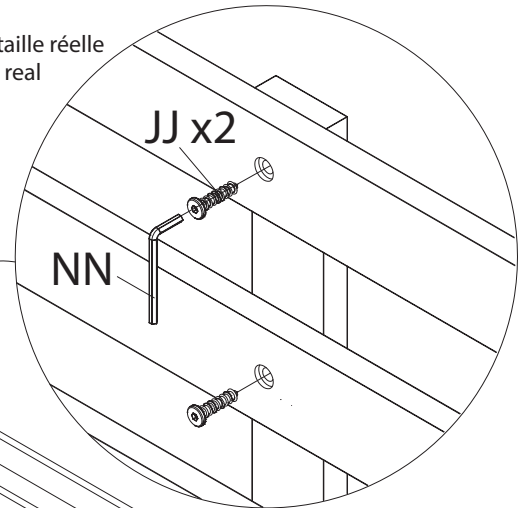

Attach and secure Semi Guard Rail onto Top Headboard Post by using (EE) and (GG) onto Ladder Side (RR) by using (DD) and (GG), tighten it up by using (NN). Attach and secure Guard Rail Support onto Semi Guard Rail by using(JJ), tighten it up by using (NN).

Fixez et sécurisez la barrière courte au support supérieur de la tête de lit (EE) et (GG), au côté de l'échelle (RR) en utilisant (DD) et (GG), serrez en utilisant (NN). Fixez et sécurisez le support de la barrière à la barrière courte en utilisant (JJ), serrez en utilisant (NN).

Unir y asegurar el semi-riel de la barandilla sobre el poste superior de la cabecera utilizando (EE) y (GG) sobre el lateral de la escalera (RR) utilizando (DD) y (GG), Apretar utilizando (NN).

Unir y asegurar el soporte del riel de la barandilla sobre el semi-riel de la barandilla utilizando (JJ), apretar utilizando (NN).

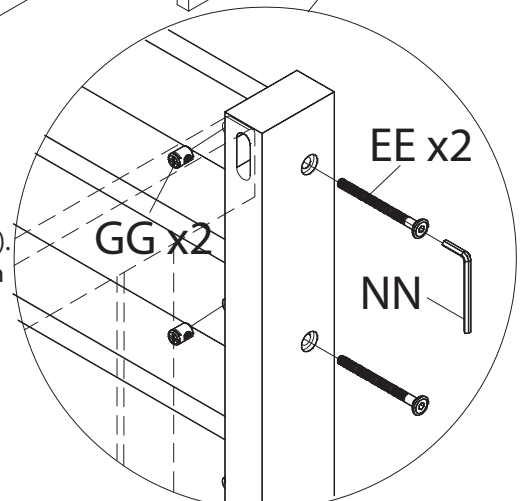



Section 2/Section 2/Sección 2

Convertible Feature

This bunk bed is able to convert to 2 single beds. Follow the instructions given.

This assembly must be completed by at least 2 person.

Fonction Convertible

Ce lit superposé peut se convertir en deux lits une place. Suivez les instructions données.

Cet assemblage doit être complété par au moins 2 personnes.

Capacidad de conversión

Esta litera se puede convertir en 2 camas individuales. Seguir las instrucciones dadas.

Este ensamblado debe ser realizado por lo menos por 2 personas.

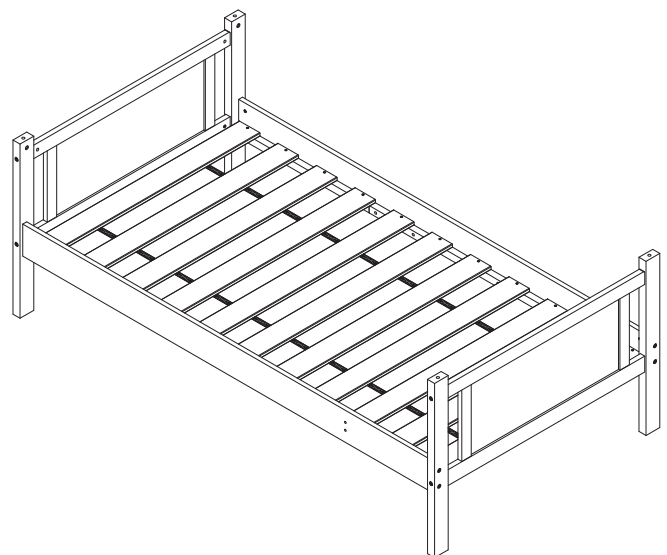
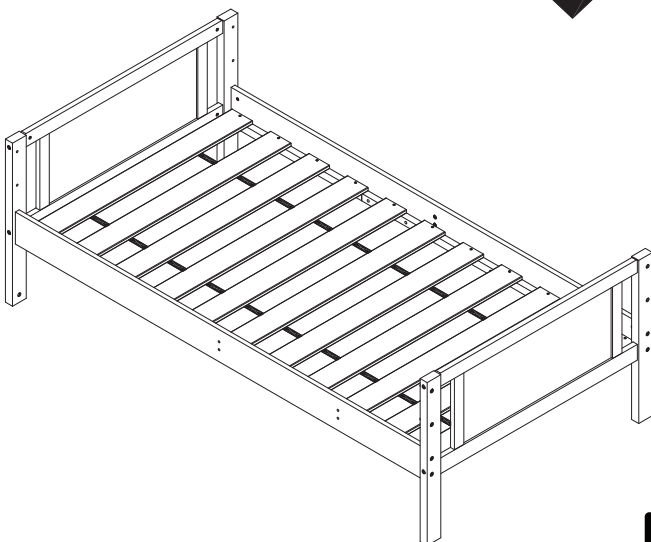
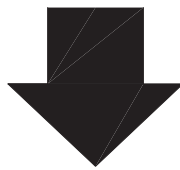
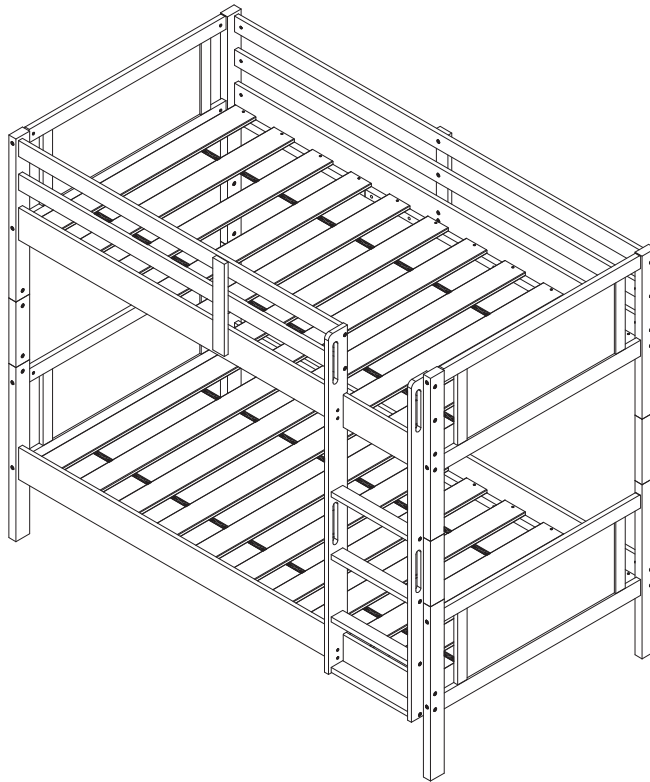

Section 2/Section 2/Sección 2

STEP 1
ÉTAPE 1
PASO 1

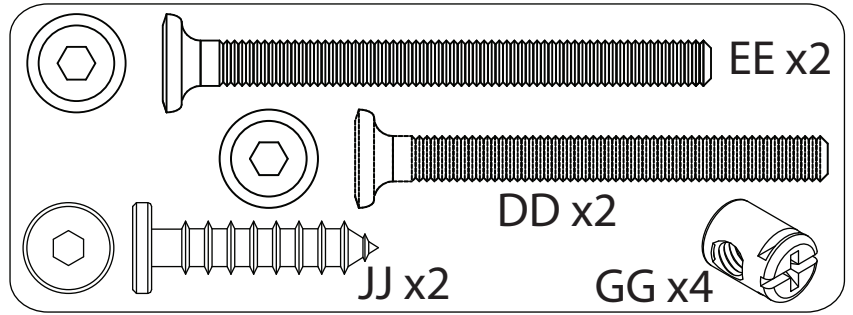
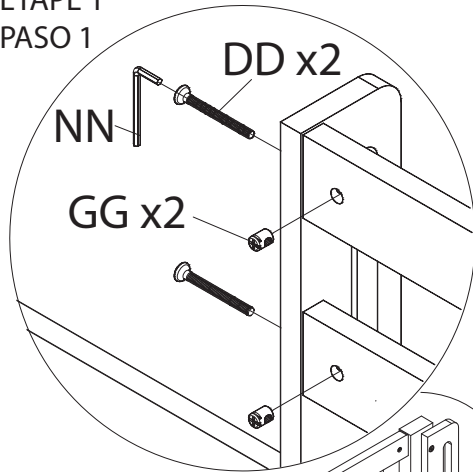

Note: Fasteners are shown full size
Remarque : les attaches sont montrées à leur taille réelle
Nota: Los sujetadores se muestran de tamaño real

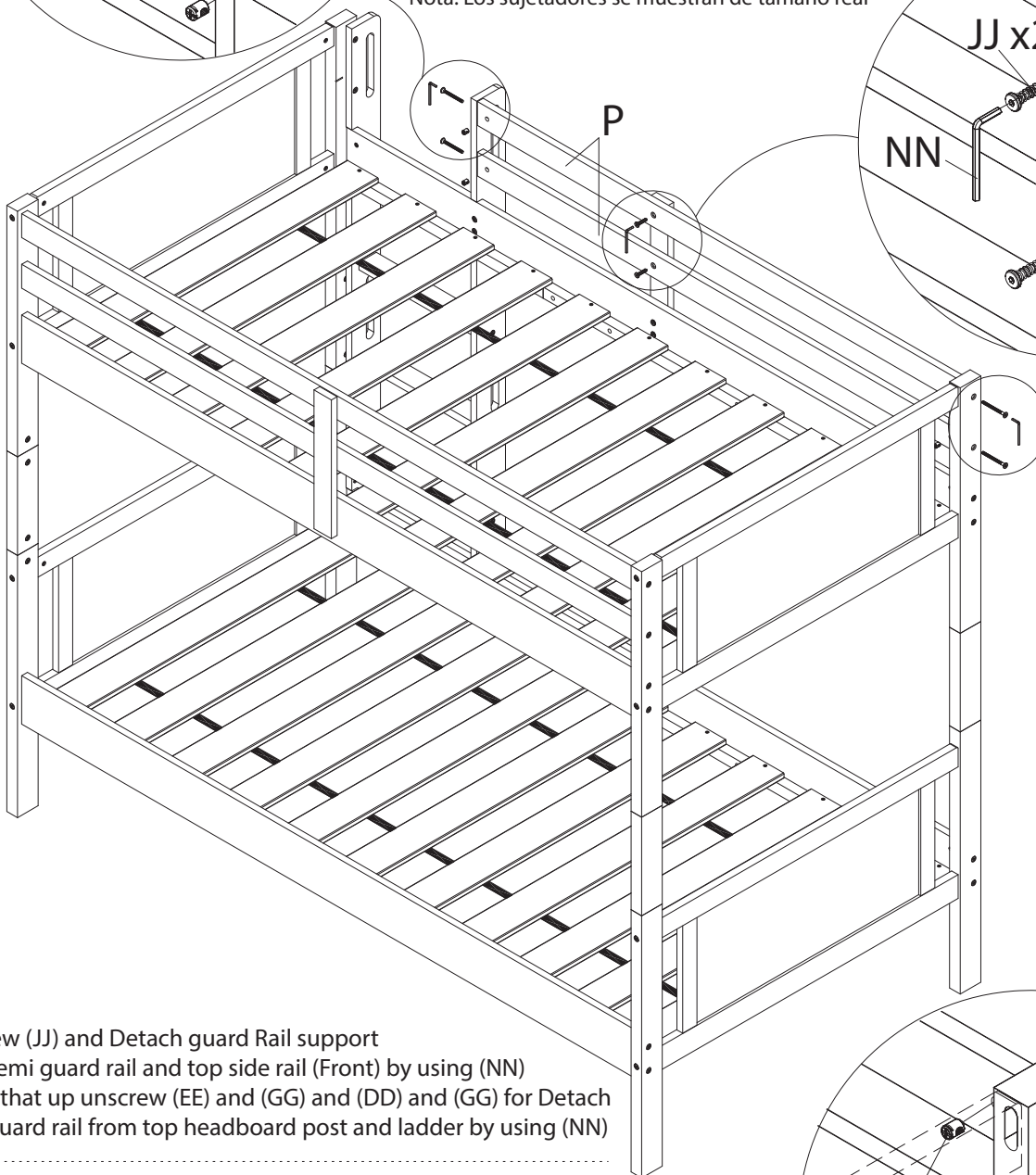
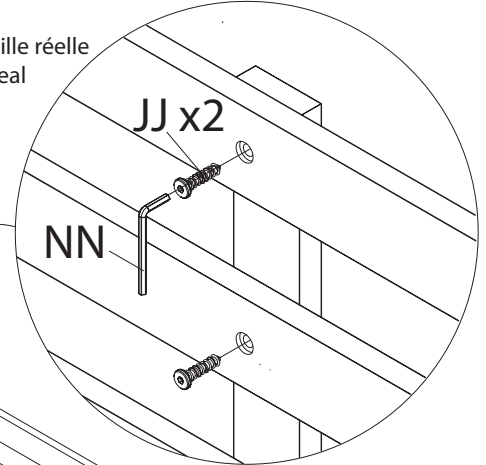

Unscrew (JJ) and Detach guard Rail support from semi guard rail and top side rail (Front) by using (NN) follow that up unscrew (EE) and (GG) and (DD) and (GG) for Detach semi guard rail from top headboard post and ladder by using (NN)

Dévissez (JJ) et détachez le support de barrière de la barrière courte et le rail supérieur latéral (Avant) en utilisant (NN). Dévissez (EE) et (GG) et (DD) et (GG) pour détacher la barrière courte du support supérieur de la tête de lit et de l'échelle en utilisant (NN).

Desatornillar (JJ) y separar el soporte del riel de la barandilla del semi-riel de la barandilla y del riel lateral superior (frontal) utilizando (NN), seguir desatornillando (EE) y (GG) y (DD) y (GG) para despegar el semi-riel de la barandilla del poste superior de la cabecera y la escalera utilizando (NN).

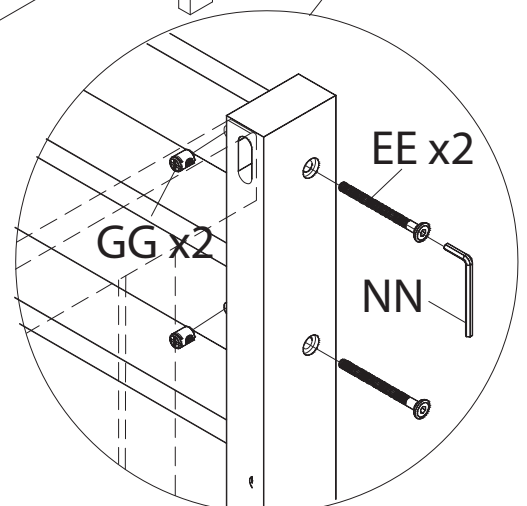



STEP 2
ÉTAPE 2
PASO 2

Section 2/Section 2/Sección 2

Note: Fasteners are shown full size
Remarque : les attaches sont montrées à leur taille réelle
Nota: Los sujetadores se muestran de tamaño real

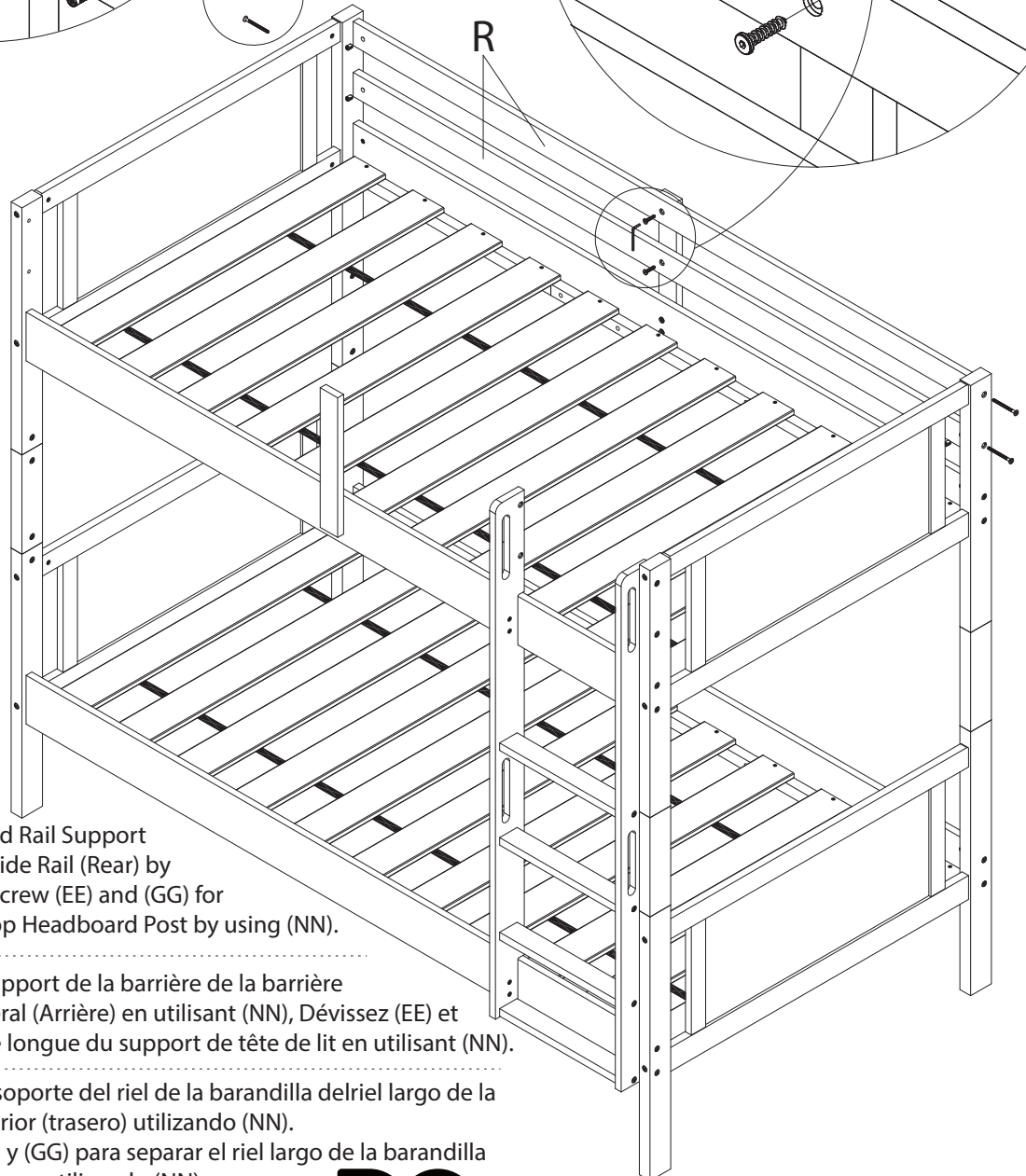
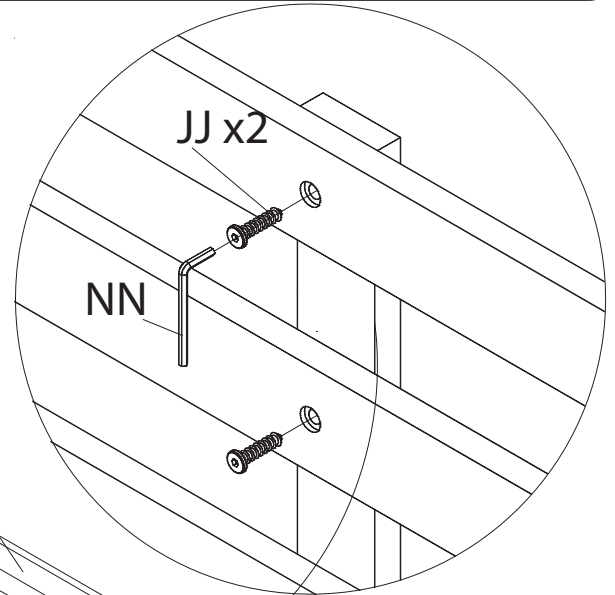
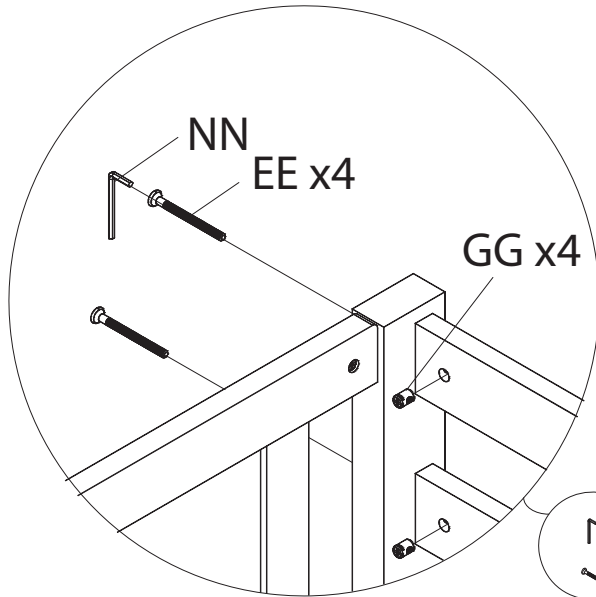
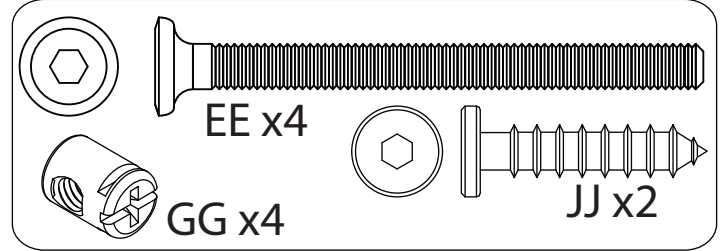

Unscrew (JJ) and Detach Guard Rail Support from Full Guard Rail and Top Side Rail (Rear) by using (NN). Follow that up Unscrew (EE) and (GG) for Detach Full Guard Rail from Top Headboard Post by using (NN).

Dévissez (JJ) et détachez le support de la barrière de la barrière longue et le rail supérieur latéral (Arrière) en utilisant (NN), Dévissez (EE) et (GG) pour détacher la barrière longue du support de tête de lit en utilisant (NN).

Desatornillar (JJ) y separar el soporte del riel de la barandilla del riel largo de la barandilla y el riel lateral superior (trasero) utilizando (NN). Continúe desatornillando (EE) y (GG) para separar el riel largo de la barandilla del poste superior de la cabecera, utilizando (NN)





STEP 3
ÉTAPE 3
PASO 3

Section 2/Section 2/Sección 2

Note: Fasteners are shown full size
Remarque : les attaches sont montrées à leur taille réelle
Nota: Los sujetadores se muestran de tamaño real

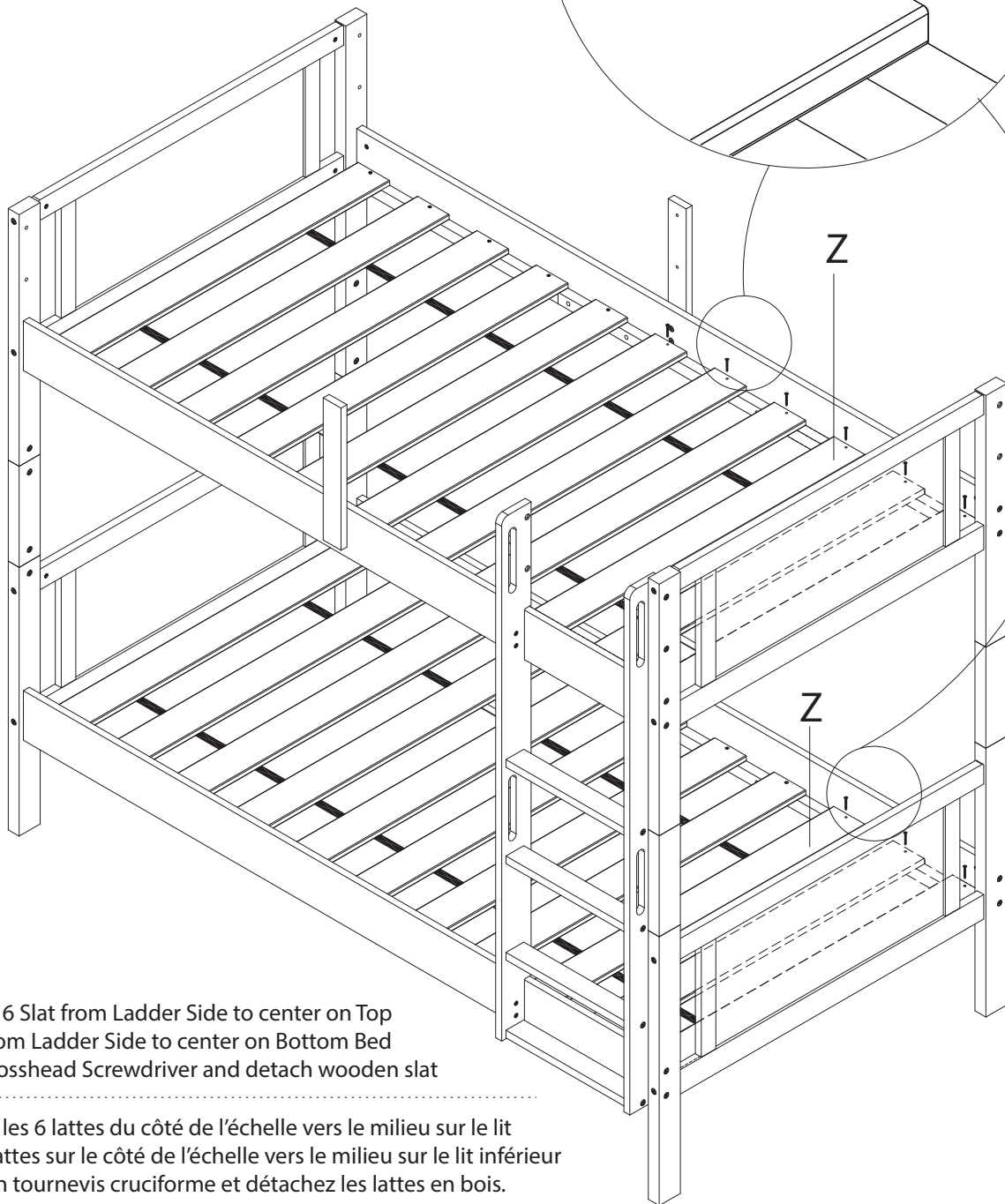
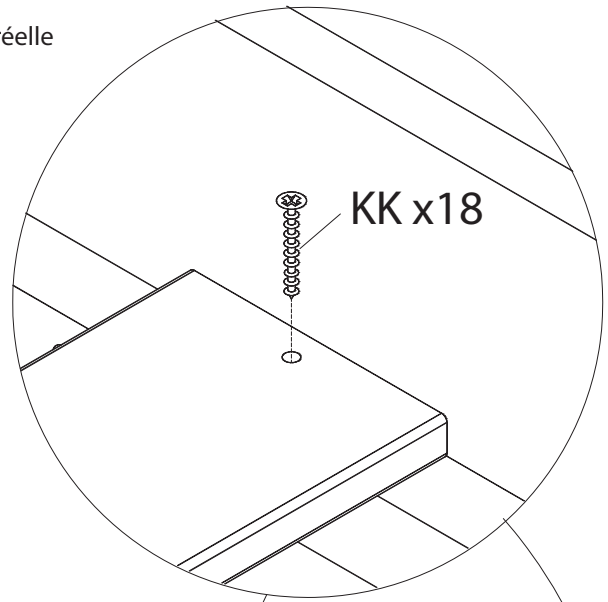
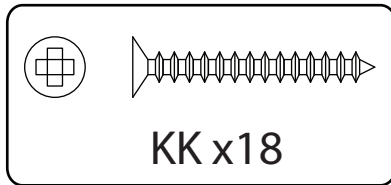

Unscrew (KK) 6 Slat from Ladder Side to center on Top Bed, 3 Slat from Ladder Side to center on Bottom Bed by using a crosshead Screwdriver and detach wooden slat

Dévissez (KK) les 6 lattes du côté de l'échelle vers le milieu sur le lit supérieur, 3 lattes sur le côté de l'échelle vers le milieu sur le lit inférieur en utilisant un tournevis cruciforme et détachez les lattes en bois.

Desatornillar (KK) 6 listones de la cama superior del lado de la escalera, 3 listones de la cama inferior del lado de la escalera, utilizando un destornillador de cruz y separe los listones de madera.





STEP 4
ÉTAPE 4
PASO 4

Section 2/Section 2/Sección 2

Note: Fasteners are shown full size
Remarque : les attaches sont montrées à leur taille réelle
Nota: Los sujetadores se muestran de tamaño real

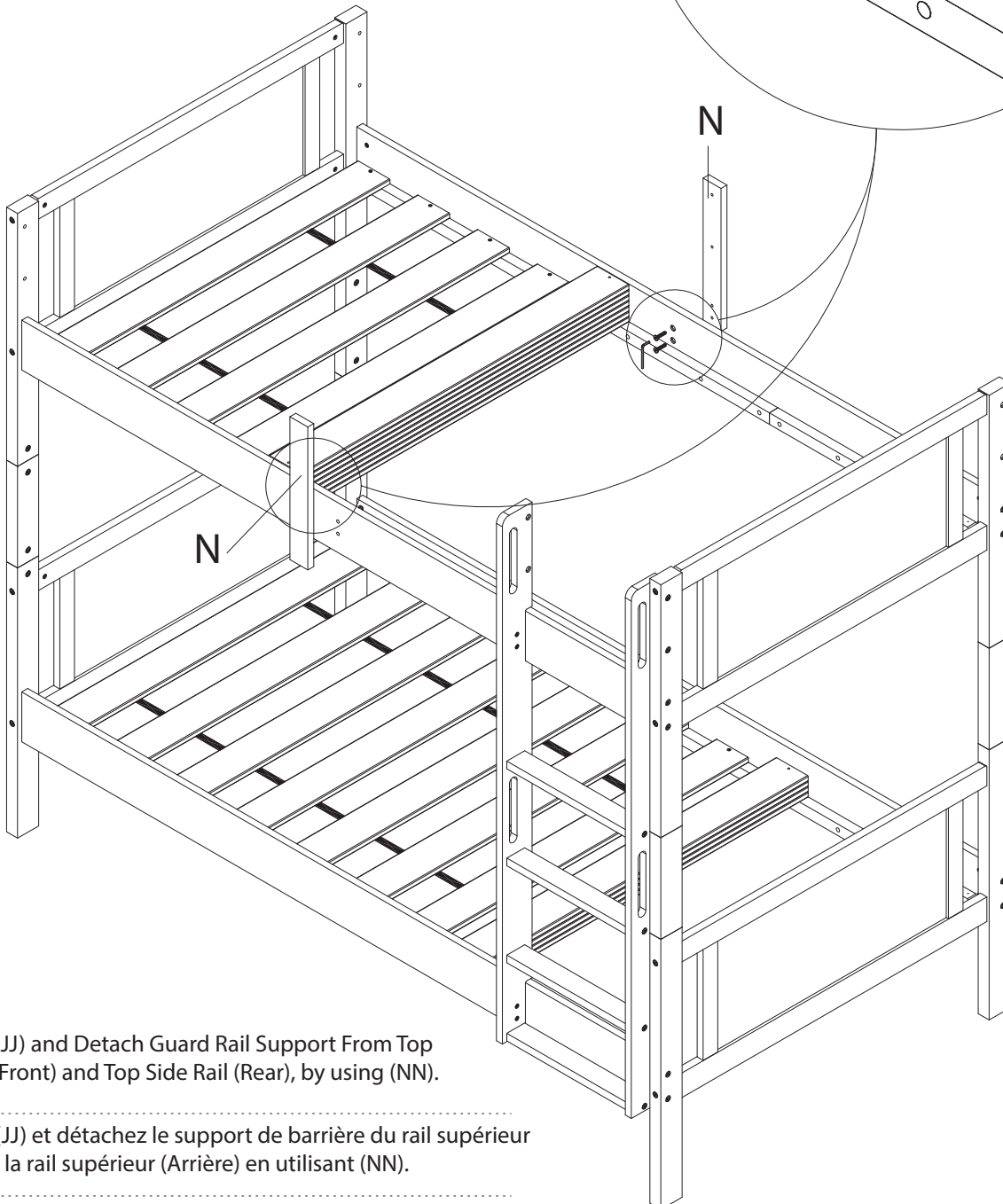
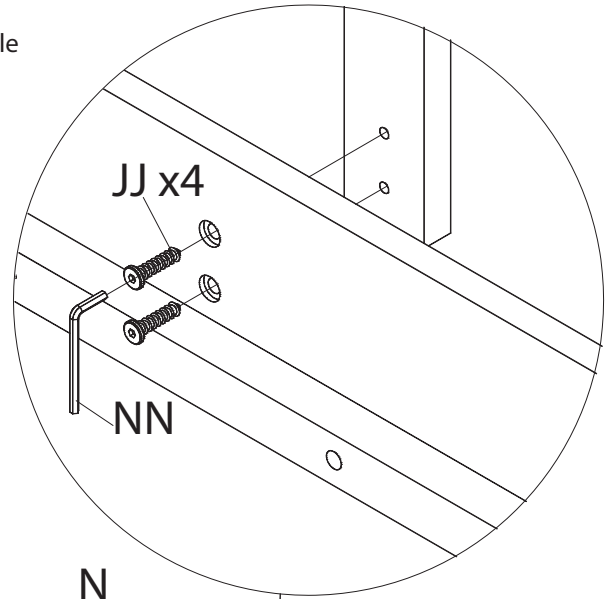
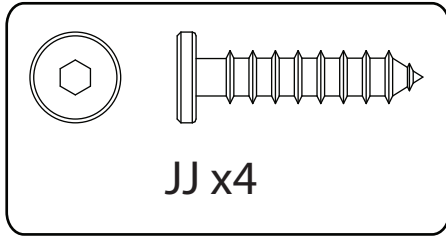

Unscrew (JJ) and Detach Guard Rail Support From Top Side Rail (Front) and Top Side Rail (Rear), by using (NN).

Dévissez (JJ) et détachez le support de barrière du rail supérieur (Avant) et la rail supérieur (Arrière) en utilisant (NN).

Desatornillar (JJ) y separar el riel de soporte de la barandilla del riel lateral superior (frontal) y el riel lateral superior (trasero), utilizando (NN).



STEP 5
ÉTAPE 5
PASO 5

Section 2/Section 2/Sección 2

Note: Fasteners are shown full size
Remarque : les attaches sont montrées à leur taille réelle
Nota: Los sujetadores se muestran de tamaño real

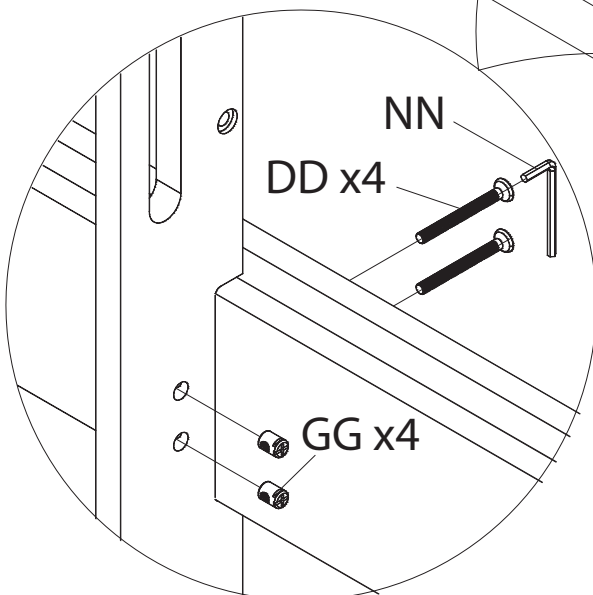
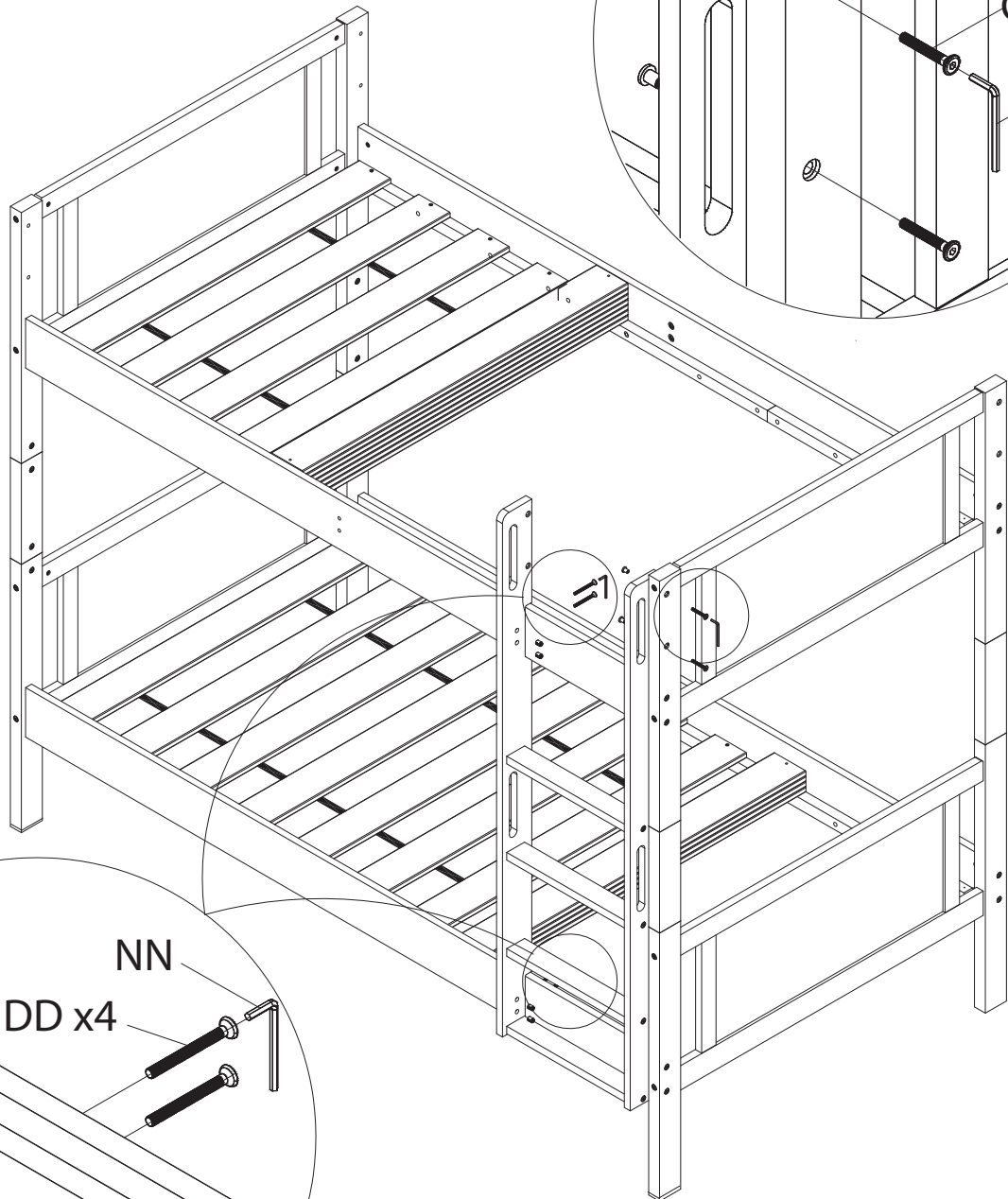
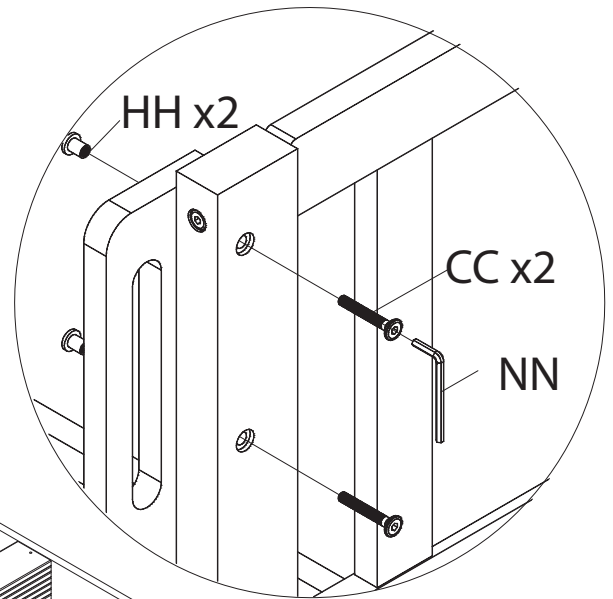
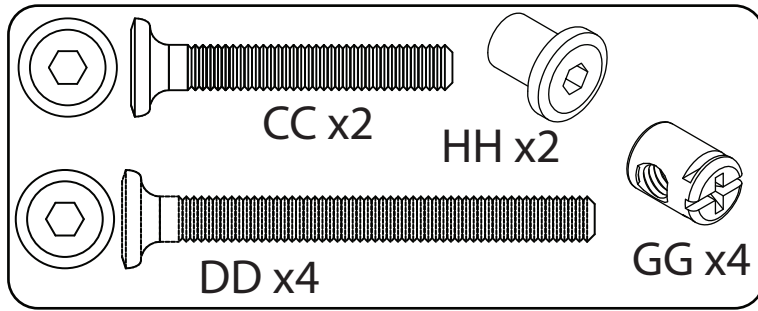

Unscrew (CC) and (HH) and (DD) and (GG), from Top Headboard Post, Ladder and Top Side Rail (Front) by using (NN).

Dévissez (CC) et (HH) et (DD) et (GG) du support supérieur de la tête de lit, l'échelle et le rail supérieur latéral (Avant) en utilisant (NN).

Desatornillar (CC) y (HH) y (DD) y (GG), del poste superior de la cabecera, escalera y riel lateral superior (frontal), utilizando (NN).





STEP 6
ÉTAPE 6
PASO 6

Section 2/Section 2/Sección 2

Note: Fasteners are shown full size
Remarque : les attaches sont montrées à leur taille réelle
Nota: Los sujetadores se muestran de tamaño real

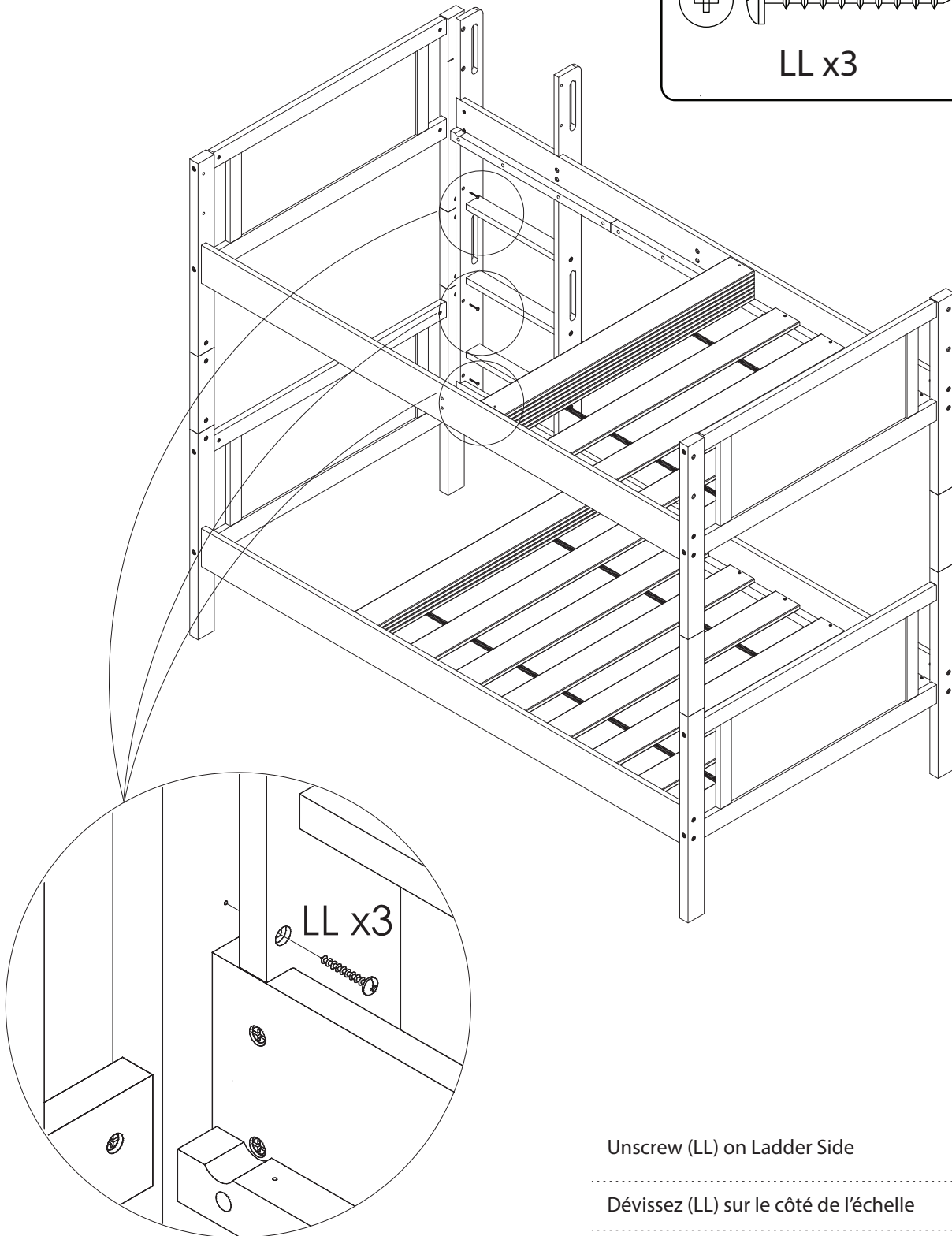
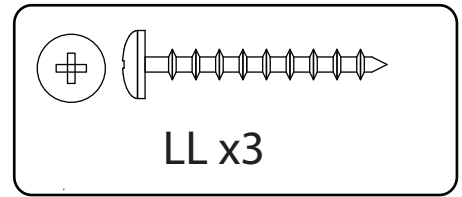

Unscrew (LL) on Ladder Side

Dévissez (LL) sur le côté de l'échelle

Desatornillar (LL) en el lado de la escalera



STEP 7
ÉTAPE 7
PASO 7

Section 2/Section 2/Sección 2

Note: Fasteners are shown full size
Remarque : les attaches sont montrées à leur taille réelle
Nota: Los sujetadores se muestran de tamaño real

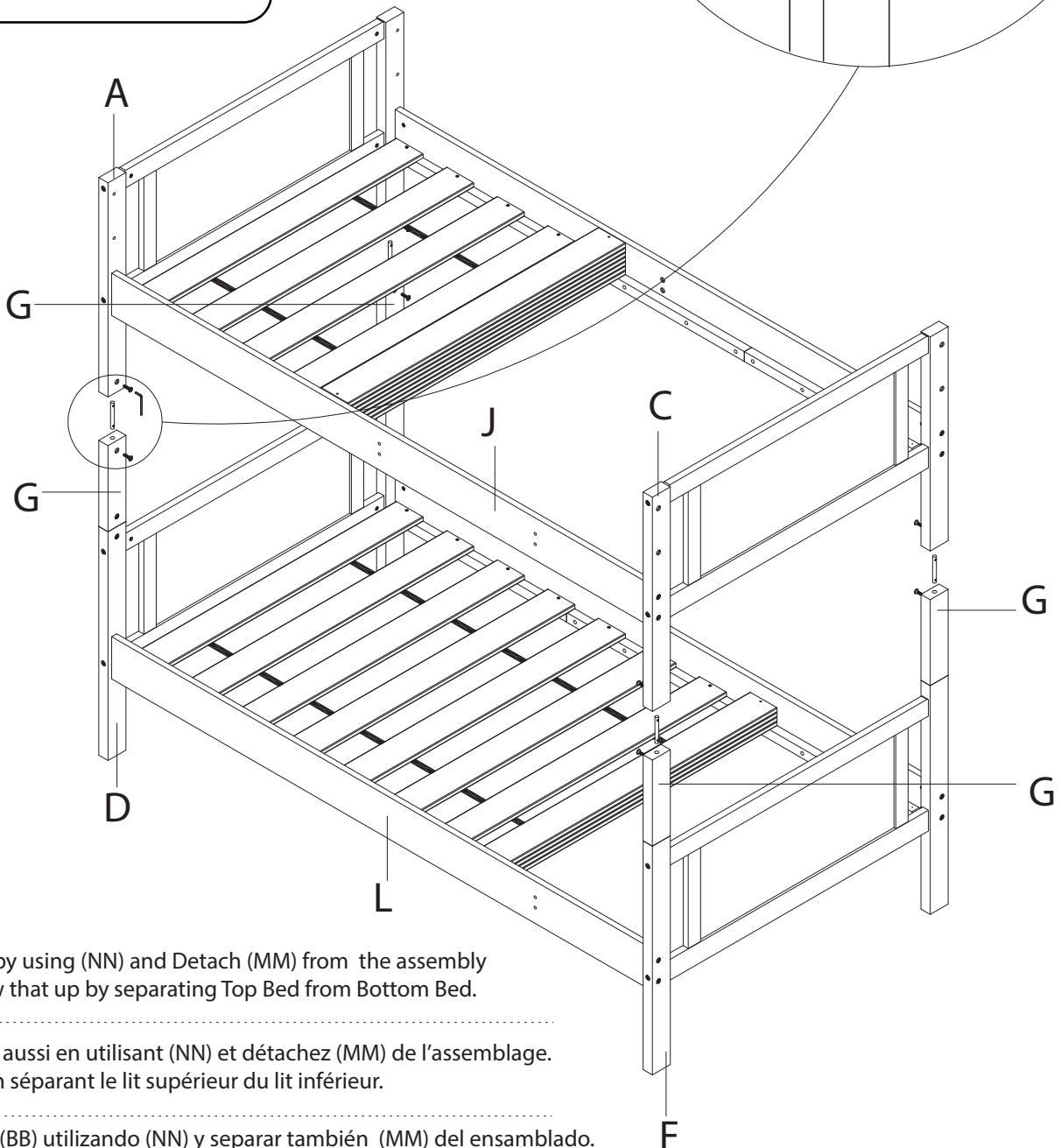
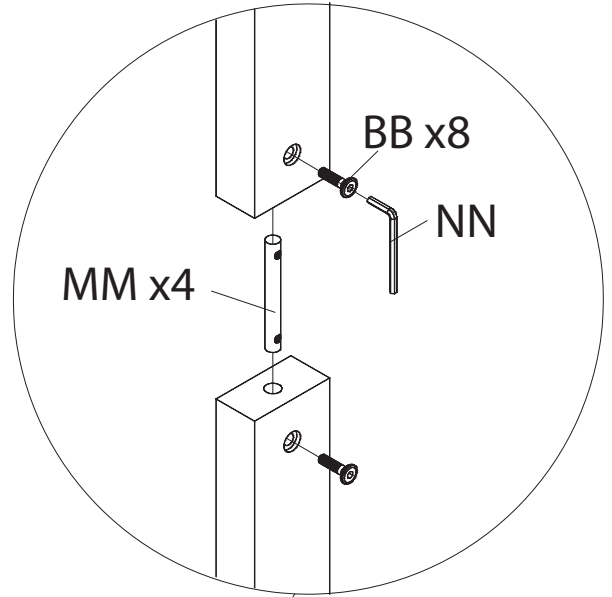
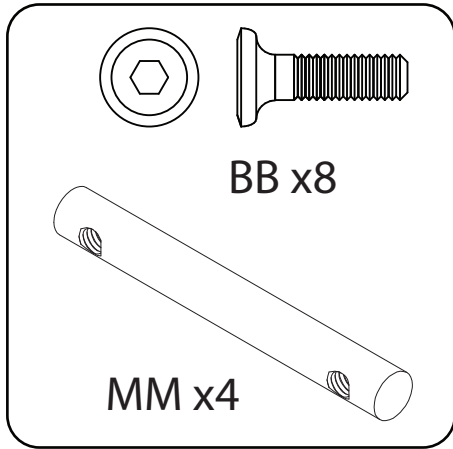

Unscrew (BB) by using (NN) and Detach (MM) from the assembly as well. Follow that up by separating Top Bed from Bottom Bed.

Dévissez (BB) aussi en utilisant (NN) et détachez (MM) de l'assemblage. Poursuivez en séparant le lit supérieur du lit inférieur.

Desatornillar (BB) utilizando (NN) y separar también (MM) del ensamblado. Continúe separando la cama superior de la cama inferior.



STEP 8
ÉTAPE 8
PASO 8

Section 2/Section 2/Sección 2

Note: Fasteners are shown full size
Remarque : les attaches sont montrées à leur taille réelle
Nota: Los sujetadores se muestran de tamaño real

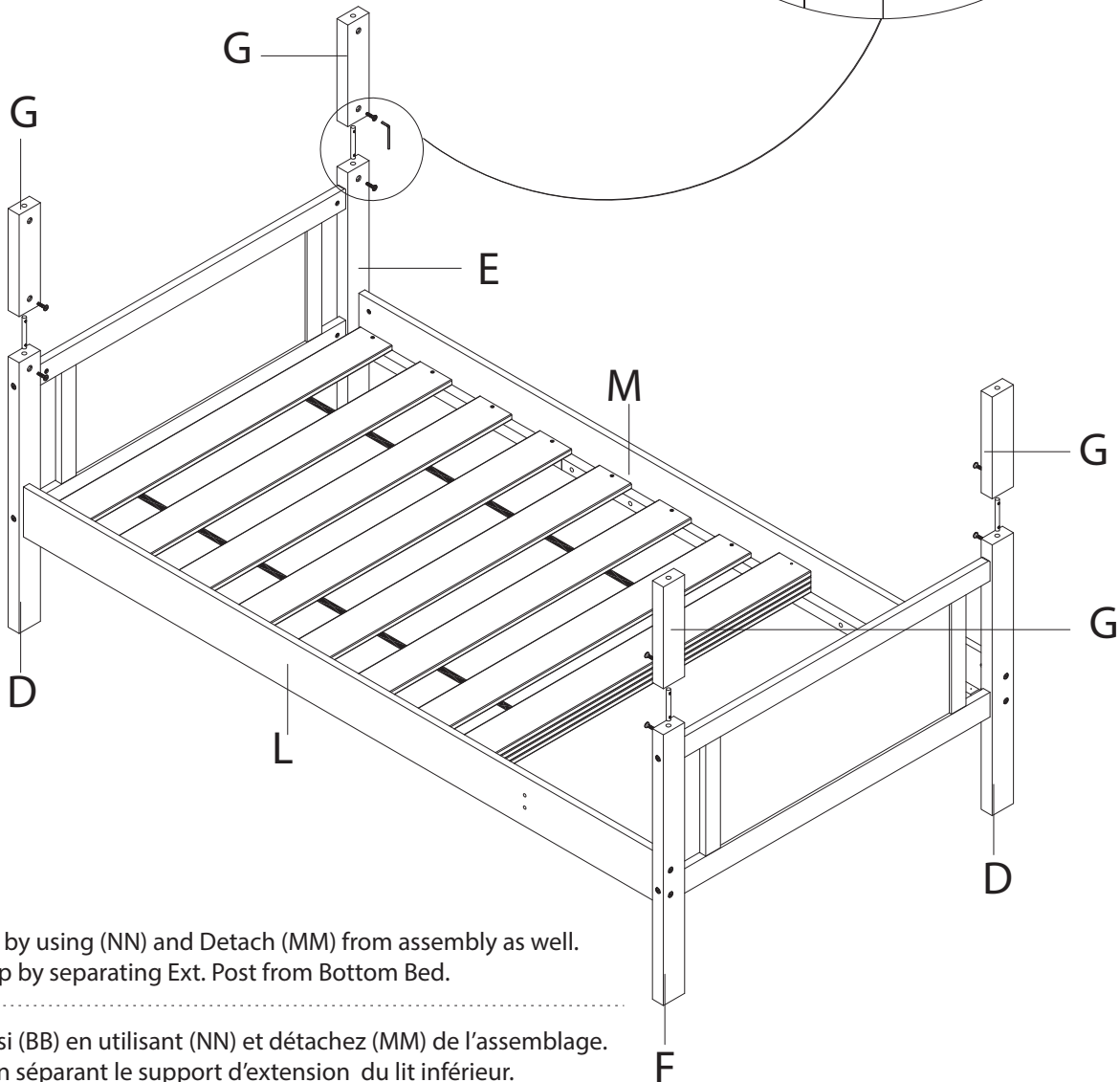
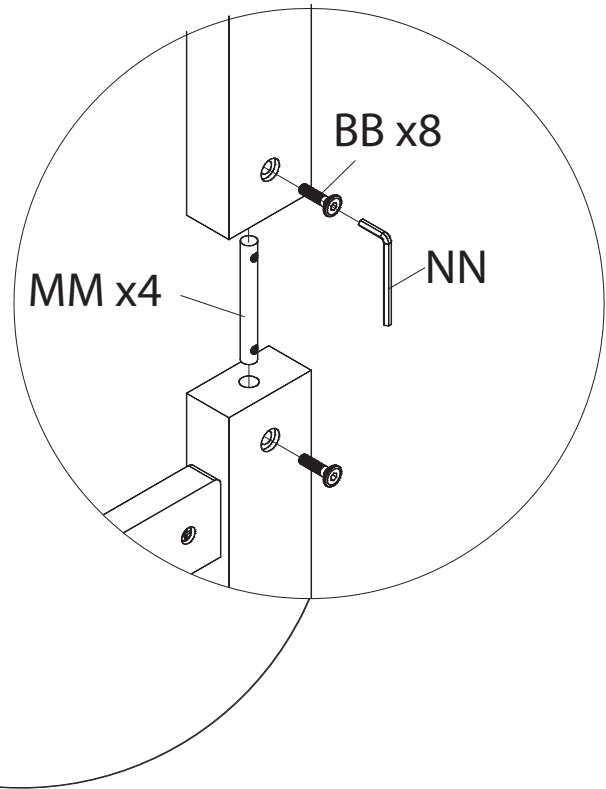
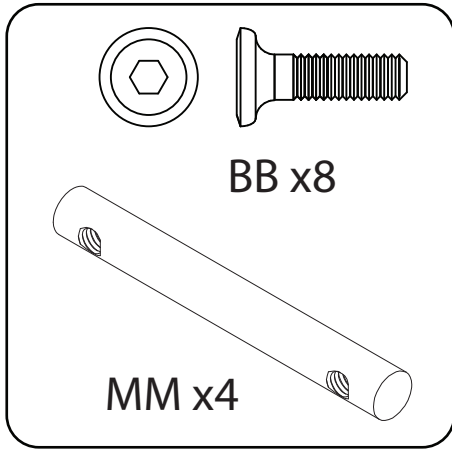

Unscrew (BB) by using (NN) and Detach (MM) from assembly as well.
Follow that up by separating Ext. Post from Bottom Bed.

Dévissez aussi (BB) en utilisant (NN) et détachez (MM) de l'assemblage.
Poursuivez en séparant le support d'extension du lit inférieur.

Desatornillar (BB) utilizando (NN) y separar también (MM) del ensamblado.
Continúe separando el poste de extensión de la cama inferior.





STEP 9
ÉTAPE 9
PASO 9

Section 2/Section 2/Sección 2

Note: Fasteners are shown full size
Remarque : les attaches sont montrées à leur taille réelle
Nota: Los sujetadores se muestran de tamaño real

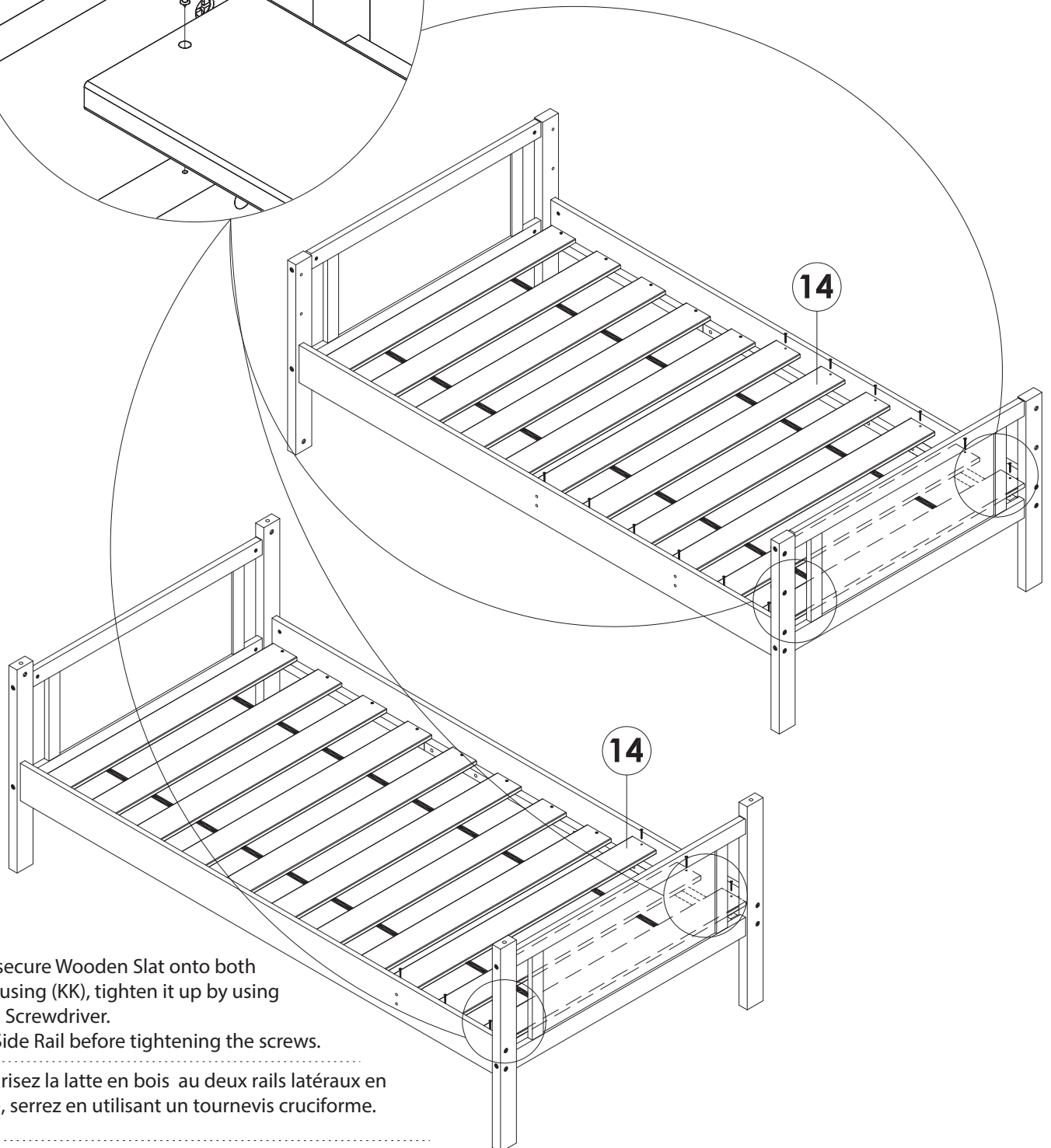
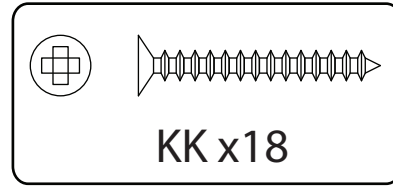
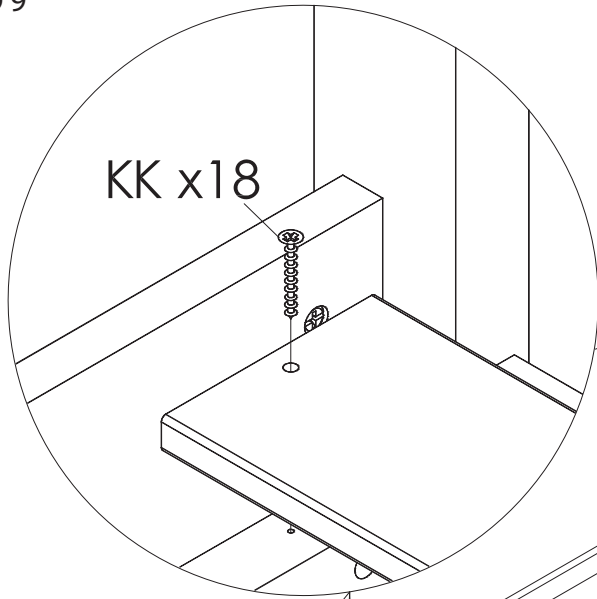

Attach and secure Wooden Slat onto both Side Rail by using (KK), tighten it up by using a Crosshead Screwdriver.
Align both Side Rail before tightening the screws.

Fixez et sécurisez la latte en bois au deux rails latéraux en utilisant (KK), serrez en utilisant un tournevis cruciforme.

Unir y asegurar los listones de madera de la cama sobre ambos rieles laterales utilizando (KK), apretar utilizando un destornillador de cruz.

Alinear ambos rieles laterales antes de apretar los tornillos.





Section 2/Section 2/Sección 2

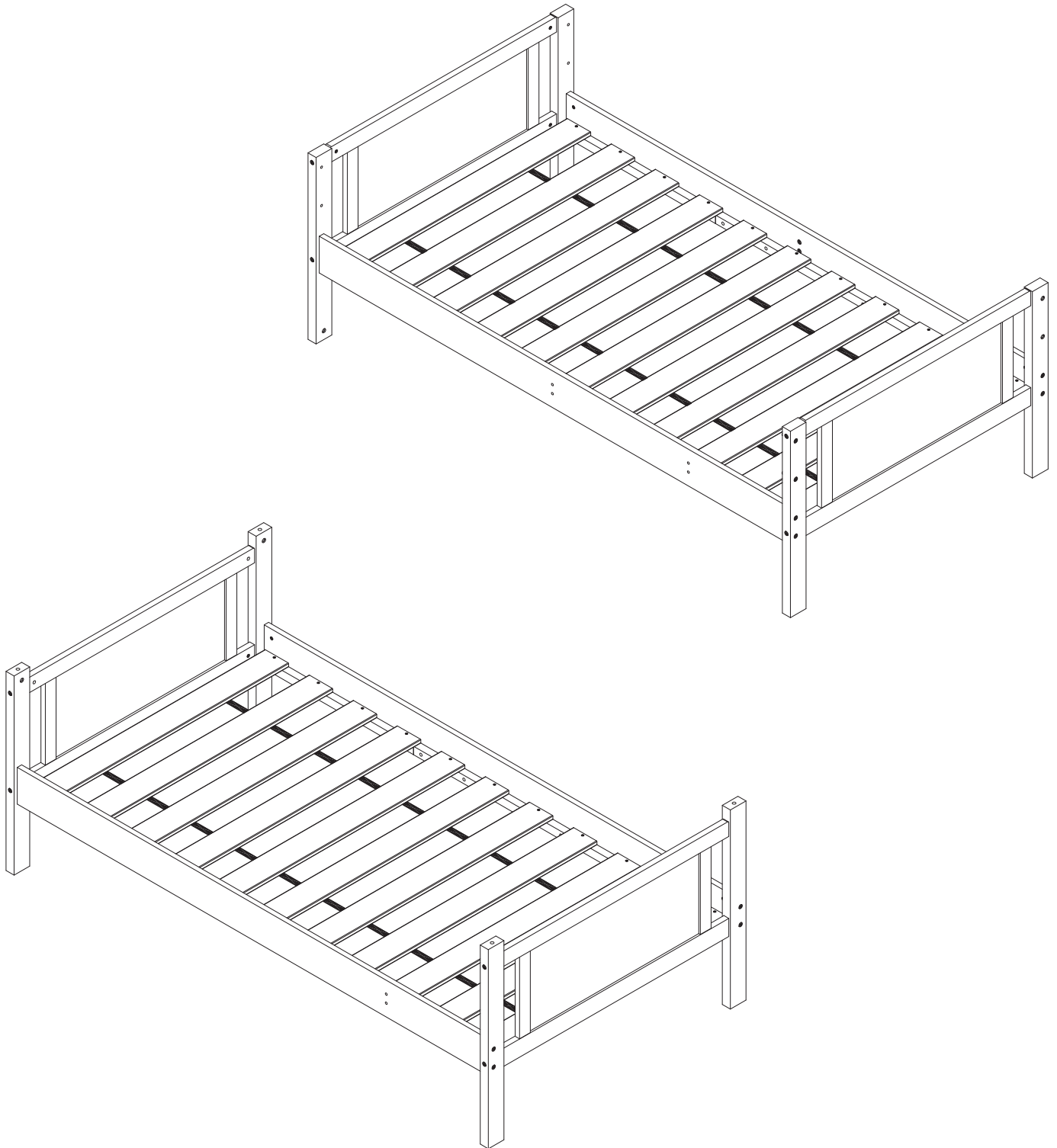

The convertible feature assembly of the Bunk Bed has been successfully completed.

L'assemblage de la version convertible du lit superposé a été complété avec succès.

La función de conversión de la litera ha sido completada con éxito.



♥♥♥

WHY CHOOSE DELTA CHILDREN?

Visit Deltachildren.Com/Pages/Our-Story for more information

<p>DELTA LEADS</p> <p>1 Out Of 2 Children In The U.S. Sleep In Our Products</p>	<p>DELTA GIVES</p> <p>10% Of Our Proceeds Go Toward Improving The Lives Of Children</p>	<p>DELTA CARES</p> <p>We Test Above & Beyond Industry Safety Standards</p>	<p>DELTA IS DEDICATED</p> <p>Our Family-Run Company Has Been There For Your Family Since 1968</p>	<p>DELTA GROWS WITH YOU</p> <p>We Have Products For Every Age And Stage</p>	<p>Over 50 Years Of Safety, Style & Innovation</p>
--	--	---	--	--	---

Welcome to the
DELTA FAMILY

Here's a Gift From Us To You

10% OFF

Your Next Purchase From
DeltaChildren.com

USE CODE:
DELTA10

*Exclusions Apply
*Subject to Change

PRODUCTS FOR EVERY AGE AND STAGE

 CRIBS	 STROLLERS	 GLIDERS	 BASSINETS	 MATTRESSES	
 BABY GEAR	 TODDLER BEDS	 PLAYROOM FURNITURE	 TWIN BEDS	 BINS & ORGANIZERS	 DRESSERS

OUR FAMILY OF TOP BRANDS



OVER 50 YEARS OF SAFETY, STYLE, AND INNOVATION



