



Read all instructions before assembly and use.  
KEEP INSTRUCTIONS FOR FUTURE USE.

Lisez toutes les instructions avant l'assemblage et l'utilisation.  
CONSERVEZ LES INSTRUCTIONS POUR UN USAGE ULTERIEUR.

Lea todas las instrucciones antes de ensamblar y usar.  
MANTENGA LAS INSTRUCCIONES PARA SU USO FUTURO.



**Toddler Sleep & Play Area**

**Espace de jeux et de sommeil pour enfants**

**Recinto Infantil para Soñar y Jugar**

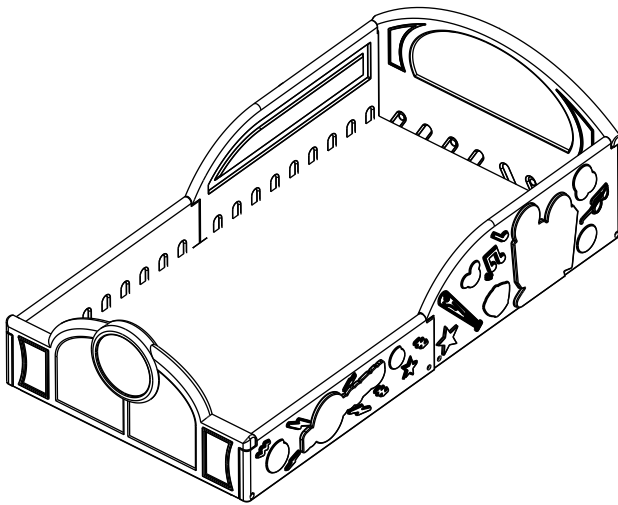

**ADULT ASSEMBLY REQUIRED**

Due to the presence of small parts during assembly, keep out of reach of children until assembly is complete.

**L'ASSEMBLAGE DOIT ETRE FAIT PAR UN ADULTE**

A cause de la presence de petites pieces, pendant l'assemblage gardez hors de portee des enfants jusqu'a ce que celui-ci soit termine.

**DEBE SER ENSAMBLADO POR UN ADULTO**

Debido a la presencia de piezas pequeñas durante el ensamblaje, mantenga fuera del alcance de los niños hasta que complete el ensamblaje.

This product is not intended for institutional or commercial use.  
Ce produit ne pas destine a un usage institutionnel ou commercial.  
Este producto no esta hecho para uso institucional o comercial.

**NEED EXTRA HELP?**

We make assembly easy with our tips & tricks video  
<https://www.deltachildren.com/pages/instructions>

**BESOIN D'AIDE SUPPLÉMENTAIRE?**

Nous facilitons l'assemblage avec nos trucs et astuces vidéo  
<https://www.deltachildren.com/pages/instructions>

**¿NECESITA AYUDA EXTRA?**

Hacemos el montaje fácil con nuestros consejos y trucos video  
<https://www.deltachildren.com/pages/instructions>

When contacting Delta Consumer Care, please reference the information on the Product Information label found on the product.

Lorsque vous contactez le Service après Vente de Delta, veuillez nous donner les références sur l'étiquette d'Information qui se trouve sur le produit.

Cuando contacte al Servicio de Atención al Consumidor de Delta por favor mencione los datos que aparecen en la etiqueta de información que se encuentra en el producto.

 **DELTA CHILDREN'S PRODUCTS CORP**  
114 WEST 26TH STREET. M / #: xxxxx  
NEW YORK, NY 10001. PO #: xxxxx LOT #: xxxxx  
Email: tcs@DeltaChildren.com D. O. M.: xxxxx  
TEL.: 646-435-8728 Base Model: BB214  
FABRIQUÉ EN CHINE  
MADE IN CHINA

Product information label  
L'étiquette d'information  
Etiqueta de información



**Consumer Care:**

Delta Children's Products Corp  
114 West 26th Street New York, NY 10001  
Tel: (646) 435-8728

Email: tcs@DeltaChildren.com

<https://www.deltachildren.com/pages/instructions>



# SAVE BIG WITH DELTA CHILDREN

Visit [Deltachildren.com](http://Deltachildren.com) To Start Shopping

Welcome to the  
**DELTA FAMILY**  
Here's a Gift From Us To You

**10% OFF**

Your Next Purchase From  
**DeltaChildren.com**

USE CODE:  
**DELTA10**

\*Exclusions Apply  
\*Subject to Change

## REVIEW TO WIN \$2500

### RULES TO ENTER



*"We LOVE, LOVE, LOVE this crib"*

My husband was impressed with the directions and organization of the hardware package. He easily assembled this crib in an hour without any help. It's very sturdy and we like that it has adjustable levels for the mattress height. To top it all off, it's so incredibly darling!!!

- 1** WRITE A REVIEW for this product on the store's website from where it was purchased
- 2** TAKE A SCREENSHOT of your review and upload it to [www.DeltaChildren.com/Review](http://www.DeltaChildren.com/Review)
- 3** IT'S THAT EASY! Upon submission, you'll be instantly ENTERED TO WIN \$2,500

### FOLLOW US FOR MORE CHANCES TO WIN



### SCAN HERE



For more information  
and to see all of our  
products



# NEED A MATTRESS ?

ORDER NOW AND SAVE 15%,  
FROM THE BRANDS YOU TRUST

*Beautyrest*



Shop [Deltachildren.com/Mattress](https://deltachildren.com/Mattress)

**USE CODE: MATTRESS15**



## ⚠️ WARNING

### INFANTS HAVE DIED IN TODDLER BEDS FROM ENTRAPMENT.

Openings in and between bed parts can entrap head and neck of a small child.

NEVER use bed with children younger than 15 months.

ALWAYS follow assembly instructions.

The maximum user weight is 50lbs (22.7kg)

## ⚠️ WARNING

### STRANGULATION HAZARD

NEVER place bed near windows where cords from blinds or drapes may strangle a child.

NEVER suspend strings over a bed.

NEVER place items with a string, cord, or ribbon, such as hood strings or pacifier cords, around a child's neck. These items may catch on bed parts.

## ⚠️ CAUTION

### ENTRAPMENT HAZARD

To avoid dangerous gaps, any mattress used in this bed shall be a full-size crib mattress at least 51 5/8 in (1310mm) in length, 27 1/4 in (690mm) in width and 4 in (100mm) in thickness. Maximum recommended mattress thickness 5 1/2 in.(140 mm).

DO NOT use this bed without a mattress.

- Failure to follow these warnings and the assembly instructions could result in serious injury or death.
- The user's maximum weight shall not be greater than 50 LB (22.7 kg).
- Guardrails are used as a mattress containment means. Guardrails provided must be used to avoid the formation of a gap between the mattress and the bed that could cause an entrapment.
- **DO NOT** use for infants. This toddler bed is intended for a child between 15 months and 5 years of age.
- **DO NOT** use a water mattress with this toddler bed.
- Toddler bed must have more than 12 inches of space between the toddler bed and solid objects such as a wall or dresser. Child could slide into small spaces and suffocate.

### **Assembly**

- IMPORTANT! Before assembly, inspect toddler bed for damaged hardware, loose joints, missing pieces or sharp edges.
- BE SURE bed rails are secure. Bed rails must be attached to headboard on the inside of the post.
- **DO NOT** use bed if any parts are missing or damaged.
- **DO NOT** substitute parts.
- If you are without an instruction sheet, **DO NOT** use this product. Call 646-435-8728 or fax (212) 645-9032.

### Care And Maintenance

To clean bed frame and bed rails, use only household soap or detergent and warm water. **NO BLEACH.**





## ⚠️ AVERTISSEMENT

**DES ENFANTS SONT MORTS DANS DES LITS POUR ENFANT POUR CAUSE DE PIÈGÉAGE.**

Les ouvertures dans et entre les pièces du lit peuvent piéger la tête et le cou d'un petit enfant.

**NE JAMAIS** utiliser ce lit pour des enfants âgés de moins de 15 mois.

**TOUJOURS** suivre les instructions d'assemblage.

Le poids de l'utilisateur ne doit pas être supérieur à 50 livres (22.7kg).

## ⚠️ AVERTISSEMENT

**DANGER DE STRANGULATION**

**NE** placez JAMAIS ce lit près de fenêtres où les cordes des stores ou rideaux peuvent étrangler un enfant.

**NE** suspendez JAMAIS des ficelles sur ce lit.

**NE** placez JAMAIS des objets avec une ficelle, une corde ou un ruban, comme une ficelle de capuche ou une corde de sucette autour du cou d'un enfant. Ces objets peuvent s'agripper aux pièces du lit.

## ⚠️ ATTENTION

**DANGER DE PIÈGÉAGE**

Pour éviter les espaces dangereux, le matelas utilisé pour ce lit sera un matelas pour lit d'enfant de taille standard d'au moins 51 5/8 pouces (1310 mm) en longueur, 27 1/4 pouces (690 mm) en largeur, et de 4 pouces (100 mm) d'épaisseur. Épaisseur maximale conseillée pour le matelas 5 1/2 pouces (140mm).

**NE PAS** utiliser ce lit s'il n'y a pas de matelas

- Une défaillance dans le suivi de ces avertissements et des instructions d'assemblage peut entraîner de sérieuses blessures ou la mort.
- Les barrières de sécurité ont pour rôle de contenir le matelas, Les barrières de sécurité fournies doivent être utilisées pour éviter la formation d'espaces vides entre le matelas et le lit qui pourraient causer un piègeage.
- **NE PAS** utiliser à destination d'un bébé. Ce lit est prévu pour un enfant entre 15 mois et 5 ans d'âge.
- **NE PAS** utiliser un matelas à eau dans ce lit pour enfant.
- Le lit pour enfant doit être placé à une distance de plus de 12 pouces de n'importe quel objet solide comme un mur ou une armoire. L'enfant pourrait glisser dans des espaces étroits et suffoquer.

### ASSEMBLAGE

- **IMPORTANT!** Avant l'assemblage vérifiez qu'il n'y ait pas de pièces endommagées, joints desserrés, pièces manquantes ou coupantes.
- **ASSUREZ VOUS** que les barres du lit sont que les barres du lit sont têtiera sur le coté intérieur du poteau.
- **NE PAS** utiliser le lit si des pièces manquent ou sont endommagées.
- **NE PAS** substituer des pièces.
- Si vous ne possédez pas la feuille d'instructions, **N'UTILISEZ** pas ce produit. Appelez au n° 646-435-8728 ou fax (212) 645-9032.

### Soin et Entretien

Pour nettoyer le cadre du lit et les barres, utilisez uniquement un savon ménager ou détergent et de l'eau tiède. **PAS DE JAVEL.**





## ⚠️ ADVERTENCIA

HAN MUERTO NIÑOS PEQUEÑOS POR QUEDAR ATRAPADOS EN CAMA PARA NIÑOS. Las aberturas que existen dentro y entre las piezas de la cama pueden atrapar la cabeza y el cuello de un niño pequeño.

**NUNCA** utilice la cama para niños menores de 15 meses.

**SIEMPRE** siga las instrucciones de ensamblaje.

El peso máximo del usuario no puede ser mayor de 50 libras(22.7kg).

## ⚠️ ADVERTENCIA

### PELIGRO DE ESTRANGULACIÓN

**NUNCA** coloque la cama cerca de ventanas donde los cordones de persianas o cortinas puedan estrangular al niño.

**NUNCA** cuelgue cordones sobre la cama.

**NUNCA** coloque artículos con cuerdas, cordones o cintas, como los cordeles de las capuchas o los cordones de los chupetes alrededor del cuello del niño.

Estos artículos podrían quedar atrapados en piezas de la cama.

## ⚠️ ATENCIÓN

### PELIGRO DE QUEDARSE ATRAPADO

Para evitar espacios peligrosos, cualquier colchón que se use en esta cama tiene que ser un colchón para cuna de tamaño completo de por lo menos 51 5/8 pulgadas (1310 mm) de largo, 27 1/4 pulgadas(690mm) de ancho y 4 pulgadas (100 mm) de espesor. Espesor máximo recomendado 5 1/2 pulgadas (140 mm).

**NO** utilice esta cama si no tiene colchón.

- El incumplimiento de estas advertencias y de las instrucciones de ensamblaje pueden resultar en lesiones graves o la muerte.
- Las barandas son utilizadas como medio de contención, Las barandas suministradas deben ser usadas para evitar la formación de espacios entre el colchón y la cama, los cuales podrían causar aprisionamiento.
- **NO** utilice para bebés. esta cama de niños es para niños de edad comprendida entre 15 meses y 5 años.
- **NO** utilice un colchón de agua en esta cama para niños.
- La cama de niños tiene que tener mas de 12 pulgadas de separación de cualquier objeto sólido, como la pared o un tocador. objeto sólido, como la pared o un tocador. El niño de podría deslizar dentro de los espacios pequeños y se podría asfixiar.

## ENSAMBLAJE

- **IMPORTANTE !** Antes del ensamblaje, inspeccione la cama de niños a ver si tiene componentes dañados, conexiones sueltas, piezas extraviadas o bordes afilados.
- **ASEGÚRESE** de que las barandas estén bien sujetas. Las barandas deben estar fijadas a la cabecera por la parte interior del poste.
- **NO** use la cama si cualquiera de las piezas están dañadas o extraviadas.
- **NO** sustituya las piezas.
- Si usted no tiene una hoja de instrucciones, **NO** use este producto. Llame al 646-435-8728 o fax(212)645-9032

## Cuidado y Mantenimiento

Para limpiar el bastidor de la cama utilice solamente jabón o detergente casero y agua tibia. **NO USE BLANQUEADOR.**





Required Tools  
Outils Nécessaires  
Herramientas necesarias



A X1

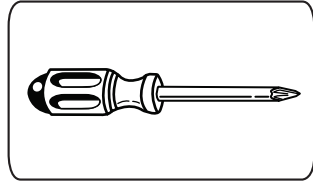

B X1

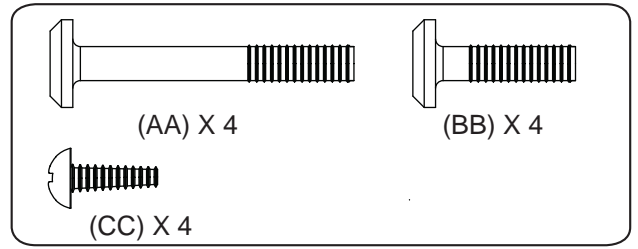

C X1

D X1

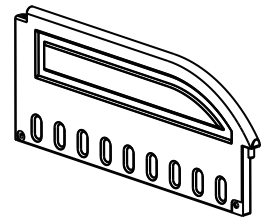
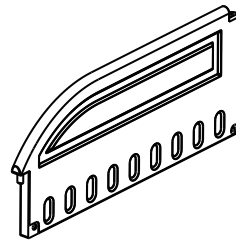
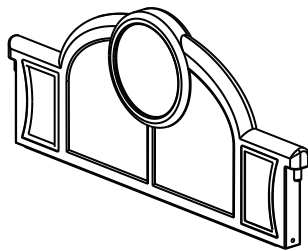
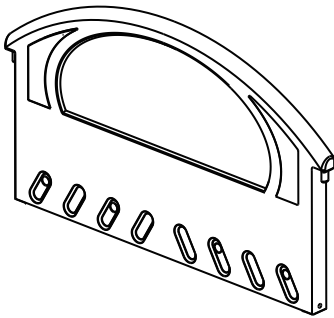

E X1

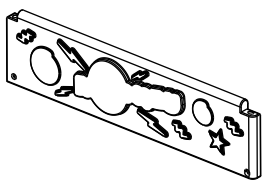

F X1

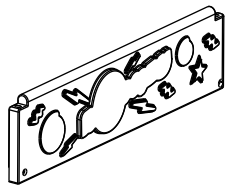

G X1

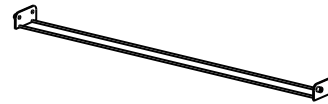

H X1

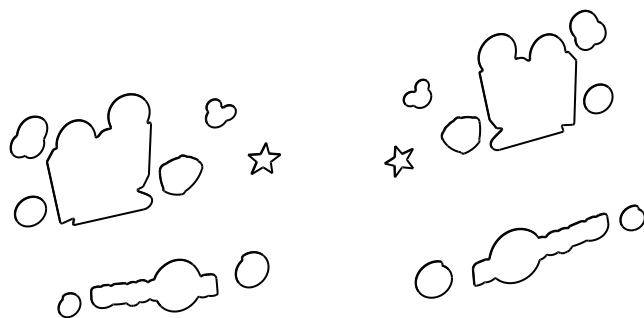
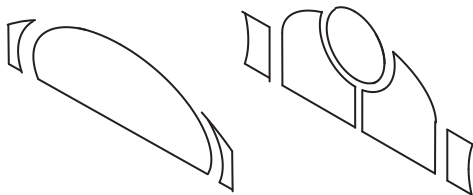

K X1

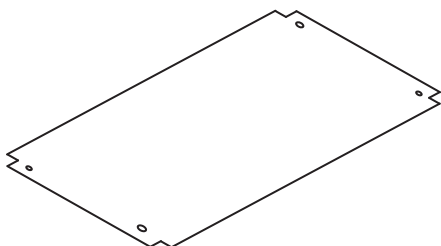

(P) CARD X 1  
(P) TARJETA X 1  
(P) CARTE X 1





- Before assembling the bed, apply stickers as shown.
- Avant d'assembler le lit, appliquez les autocollants comme il est montré.
- Antes de ensamblar la cama, aplique las etiquetas adhesivas como se muestra.

1

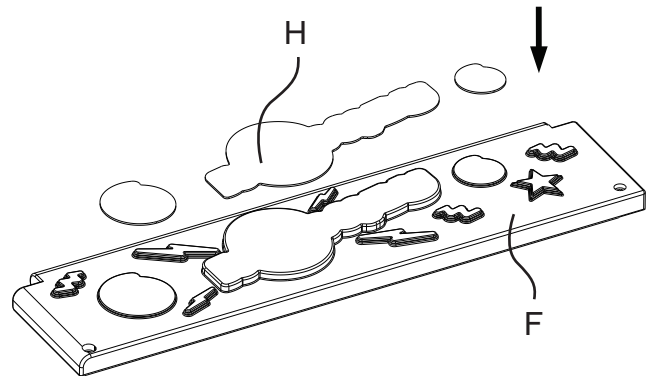
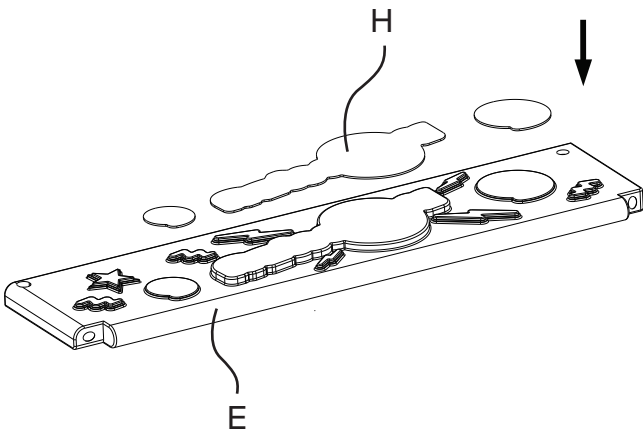
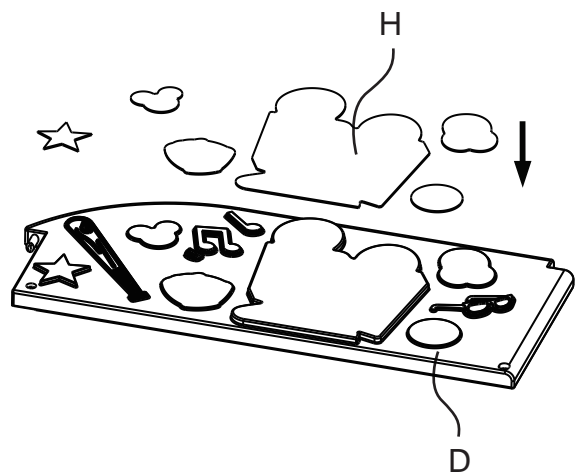
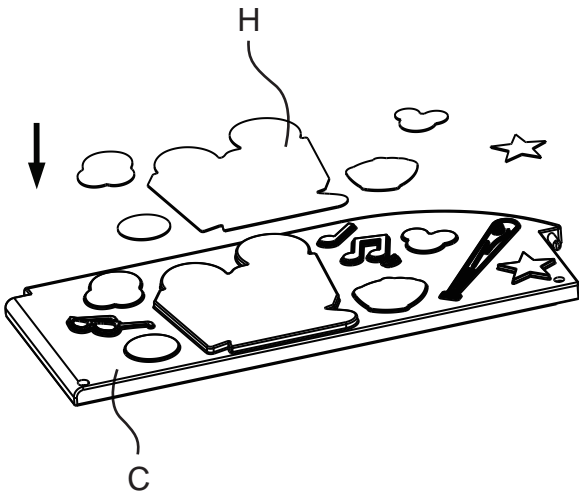
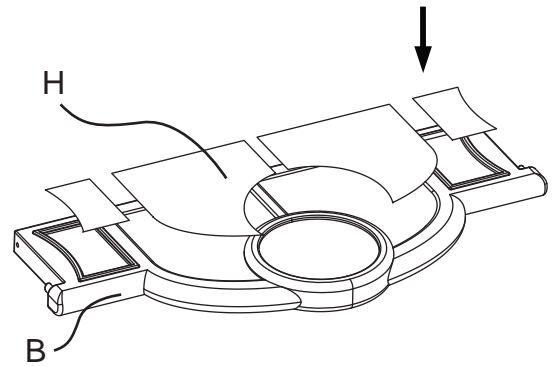
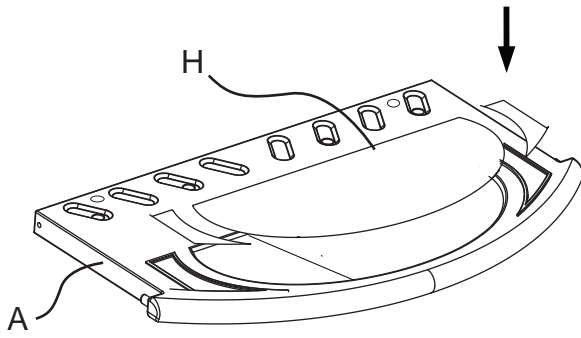

- Remove headboard decal from the cutting line. DO NOT remove the sticker. Put the whole decal on the headboard, use your hand to adjust its position on the headboard indentation.
- Saque la etiqueta adhesiva para la cabecera de la línea recortada. NO quitar el papel base de la etiqueta adhesiva. Ponga la etiqueta completa en la cabecera, utilice las manos para ajustar su posición en la hendidura de la cabecera.
- Détachez l'étiquette autocollante de la tête de lit le long de la ligne de coupe. NE PAS enlever l'autocollant. Mettez l'autocollant entier sur la tête de lit, utilisez la main pour ajuster sa position sur la marque de la tête de lit.



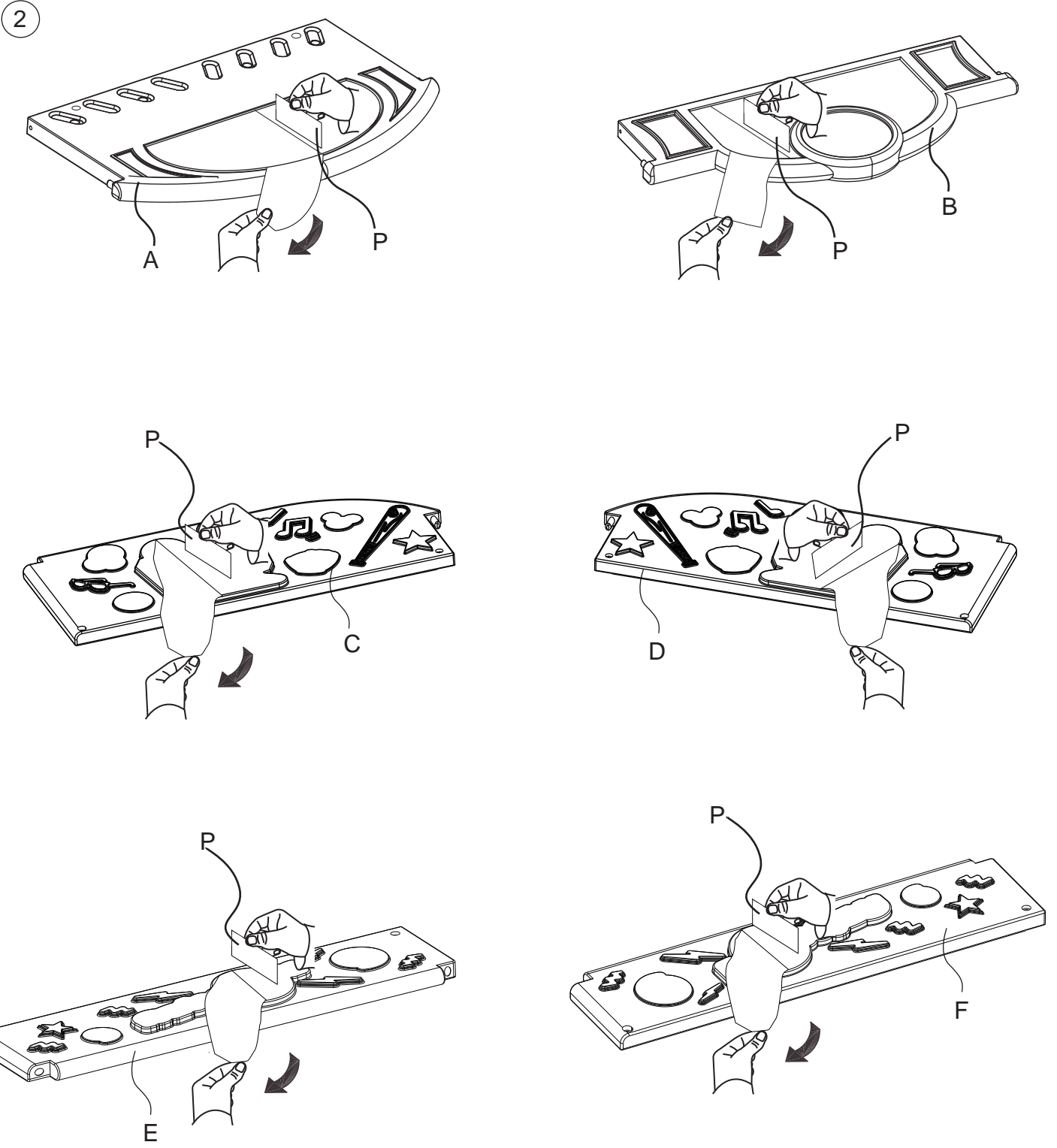

- Peel one end of the base paper and stick it on the edge of the headboard indentation.  
Slowly pull the base paper and adhere (helped by the plastic card to avoid bubbles) the sticker to the headboard.  
Use the plastic card to seal the sticker to the headboard.
- Remueva un extremo del papel base y pegue la etiqueta en el borde de la hendidura de la cabecera.  
Hale suavemente el papel base y adhiera (ayudándose con la tarjeta plástica para evitar burbujas) la etiqueta adhesiva a la cabecera.  
Utilice la tarjeta plástica para sellar la etiqueta adhesiva a la cabecera.
- Retirez une extrémité du papier de base et collez l'étiquette sur le bord de la marque sur la tête de lit.  
Tirez doucement le papier de base et faites adhérer (avec l'aide de la carte en plastique pour éviter les bulles) l'autocollant sur la tête de lit.  
Utilisez la carte en plastique pour sceller l'autocollant sur la tête de lit.



3

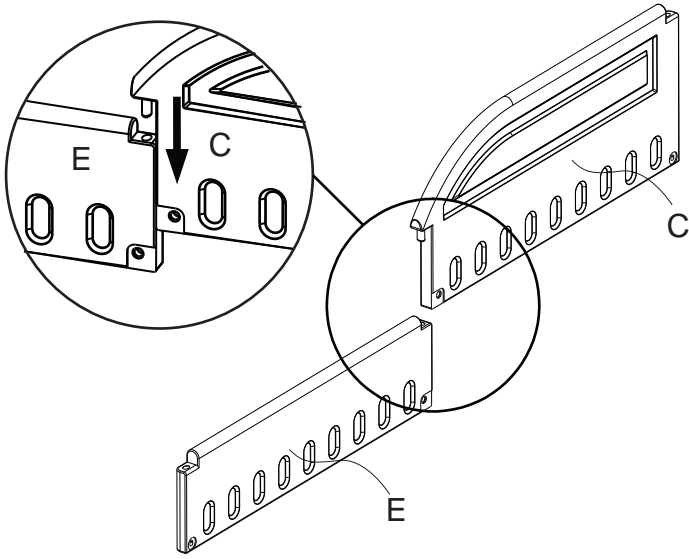

4

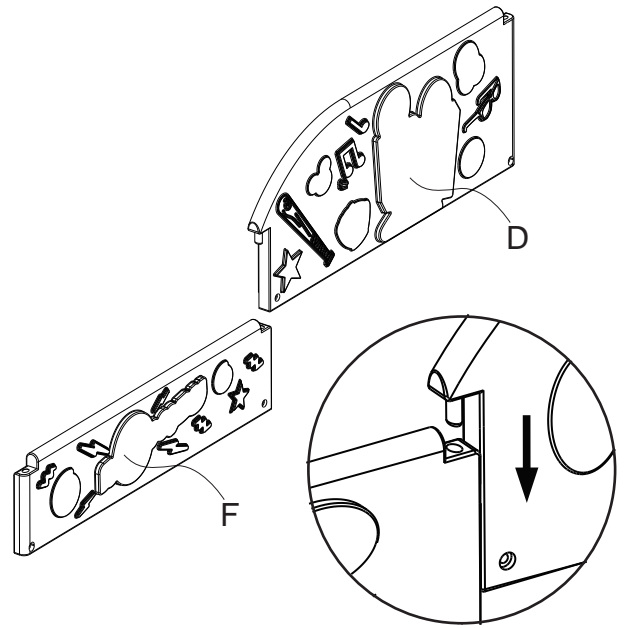

5

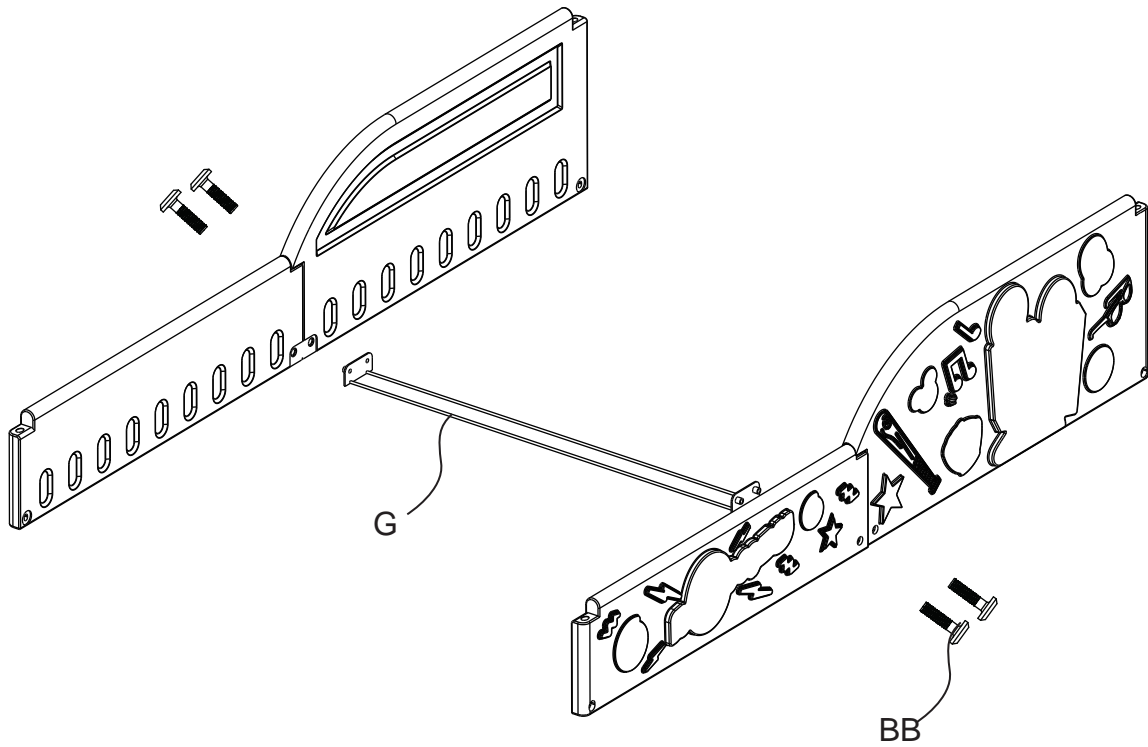

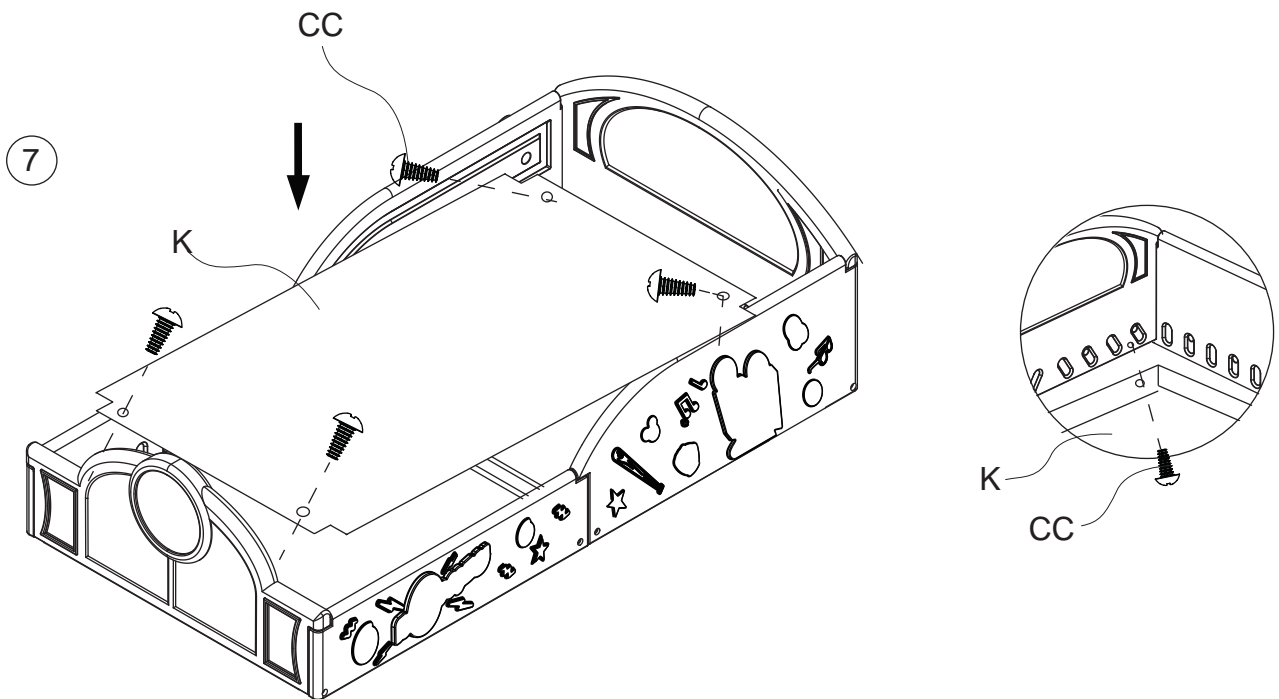
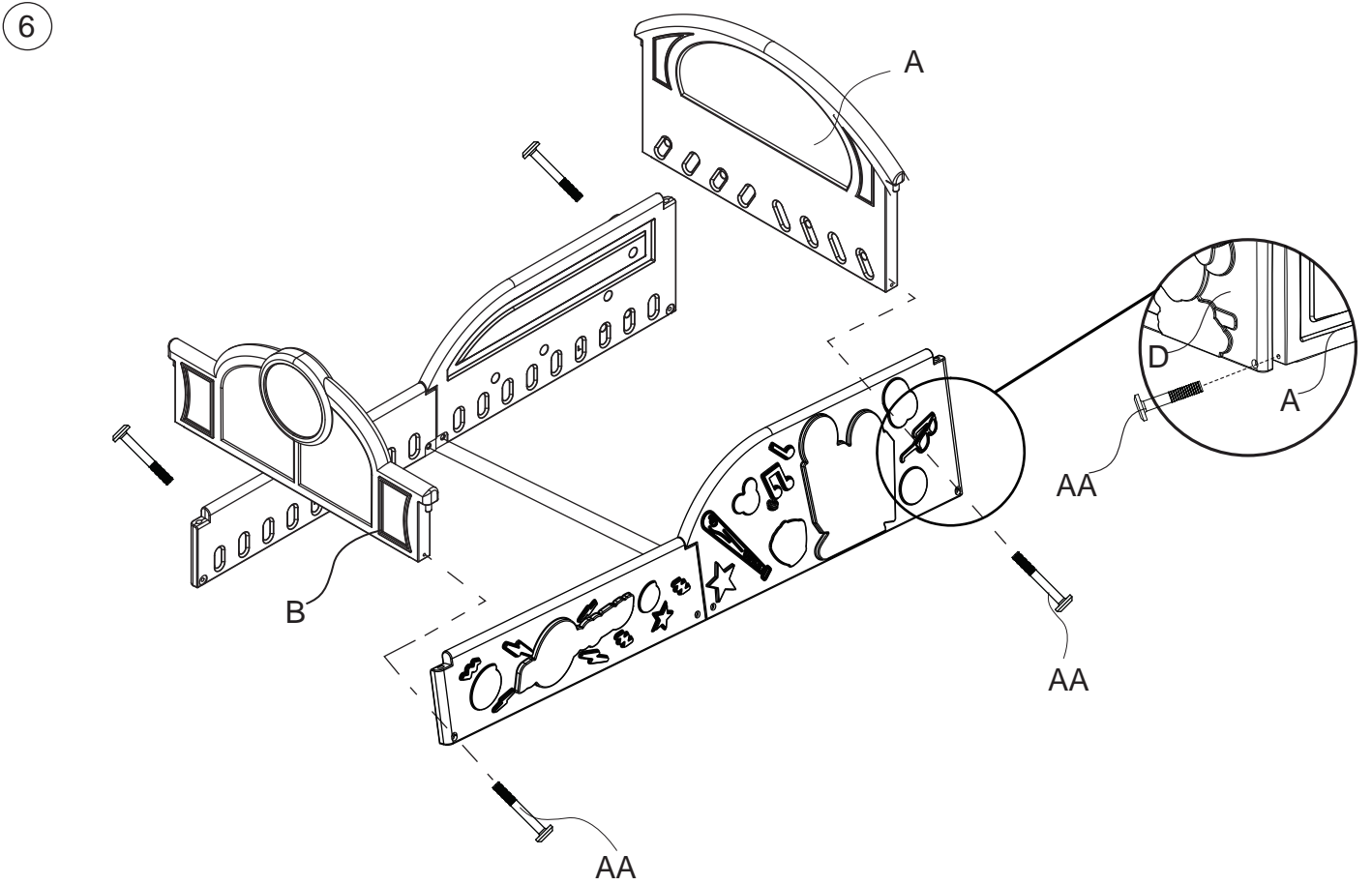

♥♥♥

# WHY CHOOSE DELTA CHILDREN?

Visit [Deltachildren.Com/Pages/Our-Story](http://Deltachildren.Com/Pages/Our-Story) for more information

<p style="text-align: center;"><b>DELTA LEADS</b></p> <p>1 Out Of 2 Children In The U.S. Sleep In Our Products</p>	<p style="text-align: center;"><b>DELTA GIVES</b></p> <p>10% Of Our Proceeds Go Toward Improving The Lives Of Children</p>	<p style="text-align: center;"><b>DELTA CARES</b></p> <p>We Test Above &amp; Beyond Industry Safety Standards</p>	<p style="text-align: center;"><b>DELTA IS DEDICATED</b></p> <p>Our Family-Run Company Has Been There For Your Family Since 1968</p>	<p style="text-align: center;"><b>DELTA GROWS WITH YOU</b></p> <p>We Have Products For Every Age And Stage</p>	<p style="text-align: center;"><b>Over 50 Years Of Safety, Style &amp; Innovation</b></p>
--------------------------------------------------------------------------------------------------------------------	----------------------------------------------------------------------------------------------------------------------------	-------------------------------------------------------------------------------------------------------------------	--------------------------------------------------------------------------------------------------------------------------------------	----------------------------------------------------------------------------------------------------------------	-------------------------------------------------------------------------------------------

Welcome to the  
**DELTA FAMILY**

Here's a Gift From Us To You

# 10% OFF

Your Next Purchase From  
[DeltaChildren.com](http://DeltaChildren.com)

USE CODE:  
**DELTA10**

\*Exclusions Apply  
\*Subject to Change

## PRODUCTS FOR EVERY AGE AND STAGE

 CRIBS	 STROLLERS	 GLIDERS	 BASSINETS	 MATTRESSES	
 BABY GEAR	 TODDLER BEDS	 PLAYROOM FURNITURE	 TWIN BEDS	 BINS & ORGANIZERS	 DRESSERS

## OUR FAMILY OF TOP BRANDS



OVER 50 YEARS OF SAFETY, STYLE, AND INNOVATION



1.Revision Date:	2019/06/21	Revision Note:	更改产品名称, 更新使用新版本说明书
2.Revision Date:	20200916	Revision Note:	更新新版本Logo
3.Revision Date:		Revision Note:	
4.Revision Date:		Revision Note:	
5.Revision Date:		Revision Note:	
6.Revision Date:		Revision Note:	

**注：此页面仅为更新记录，测试，大货不用印刷此页，**