

WRANGLER DELUXE

4 SEAT
STROLLER WAGON

Jeep®

by DELTA CHILDREN

INSTRUCTION MANUAL

ADULT ASSEMBLY REQUIRED
STYLES AND COLORS MAY VARY

60008A



**▲ WARNING:
CHOKING HAZARD**

Adult assembly required because of small parts. Keep assembly parts out of reach of children under 3 years.

Read all instructions BEFORE assembly and USE of product
KEEP INSTRUCTIONS FOR FUTURE USE.

Customer Experience Center
email: gcs@DeltaChildren.com

DELTA♥CHILDREN

www.DeltaChildren.com

DCP-IM-08172023

WARNING

WARNING: Please follow all of these instructions to ensure the safety of your child. Keep these instructions for future reference.

WARNING: Failure to follow these instructions could result in serious injury or death.

WARNING: Avoid serious injury from falling or sliding out. Always ensure that the child is properly positioned by using the safety harness according to these instructions.

WARNING: Never leave children unattended.

WARNING: INJURY HAZARD: Do not use the shade flaps during high wind conditions. Product may become unstable and tip-over causing injury to occupants.

CAUTION: This is a double occupant stroller wagon for two children only. The use of more than four children may cause an unstable condition which can injure your child. Do not place parcels, diaper bags or accessory items on sides of wagon or handles as this can cause an unstable condition.

- The maximum weight that can be carried in front zippered storage bag is 5 pounds (2.3kg).
- The maximum weight that can be carried in the cooler bag is 15 pounds (6.8kg).
- The maximum weight that can be carried in the wagon is 200 pounds (90.72 kg) combined. Any additional weight will cause a hazardous unstable condition.
- Use of the wagon with children weighing more than 50 pounds (22.68 kg) or over 42 inches (106.7 cm) tall in each seat, may cause a hazardous unstable condition to the wagon
- **ALWAYS** lift wagon from handlebar when going over curbs.
- **ALWAYS** remove canopies before folding.
- **ALWAYS** lock brakes when adding and removing children from wagon, or when parked.
- **NEVER** allow children to play with this product.
- **NEVER** allow children to play in or around the wagon. This wagon is not a toy.
- **NEVER** use the wagon on stairways, escalators, or moving walkways.
- **NEVER** use the wagon in conjunction with bicycles, skateboards, roller skates, or in-line skates.
- **NEVER** use on unstable or uneven terrain.
- **NEVER** put child inside wagon when using wagon as storage for other items.
- **NEVER** use near open flames or other sources of heat.
- **NEVER** sit on top rail or canopy, doing so may cause a hazardous unstable condition.
- **NEVER** install mattresses or similar items for use in wagon. Doing so may cause a hazardous unstable condition.
- **NEVER** allow children to stand up or place arms and legs outside of wagon while moving.
- **NEVER** leave wagon on sloped surface even if brakes are engaged.
- We recommend that the child occupant needs to be 6 months of age, at the minimum, before use of the wagon.

CARE AND MAINTENANCE

- To clean the wagon use a mild household soap with warm water on a sponge or clean cloth.
- Check your wagon for loose screws, worn parts, torn material or stitching on a regular basis. Replace or repair parts as needed.
- Discontinue use of wagon if it should become damaged or malfunctions. Please contact our customer service email at gcs@DeltaChildren.com to arrange for repair or obtain replacement parts.
- If you experience any difficulty with assembly, missing parts or use, please DO NOT return this item to the store. Retail stores are unable to properly assist you. Contact our Customer Service Department directly for assistance gcs@DeltaChildren.com

DELTA CHILDREN

LIMITED MANUFACTURER WARRANTY

This Delta product is warranted to be free from defects for a period of 90 days from the date of purchase under normal use. This warranty extends only to the original retail purchaser and is valid only when supplied with proof of purchase, or if received as a gift, when the registration is on file with Delta. This limited manufacturer warranty does not cover the following:

- Products purchased as floor models or samples.
- Items purchased on an “as-is” basis, as a second hand product, or as a resale product.
- Items purchased at a Final sale, a “Going out of Business” sale, or a Liquidation sale.

TO REGISTER YOUR PRODUCT for important safety alerts and updates to your product please visit www.deltachildren.com

TO REPORT A PROBLEM, please log on to www.deltachildren.com and click the Consumer Care Tab, or contact us by email at gcs@DeltaChildren.com.

Date of Purchase: _____ (you should also keep your receipt)

EXTENDED WARRANTY

DON'T MISS YOUR CHANCE TO BE COVERED FOR ALL OF LIFES MISHAPS!

With Delta's Extended Warranty, you're covered for mechanical failure from normal use or if your item stops working due to normal wear and tear, plus all those unexpected surprises.

2 YEARS OF PROTECTION

For Additional Information:

Simply visit our Website, register your product, and add the Extended Warranty

<https://www.deltachildren.com/pages/product-registration>

Extended Warranty only available in the following States: Arkansas, Colorado, Delaware, District of Columbia, Georgia, Idaho, Illinois, Indiana, Iowa, Kansas, Kentucky, Louisiana, Maryland, Michigan, Mississippi, Missouri, Nebraska, Nevada, New Hampshire, New York, North Carolina, North Dakota, Pennsylvania, Rhode Island, South Dakota, Tennessee, Utah, West Virginia

PARTS

IMPORTANT! Please remove all parts from the package and identify them before assembly.
IMPORTANT! Before assembly and each use, inspect this product for damaged hardware, loose joints, missing parts, or sharp edges. NEVER use if any parts are missing or broken. Contact manufacturer for replacement parts and instructions if needed. Never substitute parts. **IMPORTANT!** Adult assembly is required.



Front Wheel (x2)
(Lock & Swivel)



Rear Wheel (x2)



Rear Wheel Axle



Rear Axle Connection Tubes (x2)
(Ships inside of Cooler Bag)



Wagon Frame
*Shown folded with soft goods attached



Leatherette Handlebar Cover (x2)



Cup Holder (x2)
(Ships inside of Cooler Bag)



Canopy (Folded)



Canopy Frame



Removable Seats (x2)

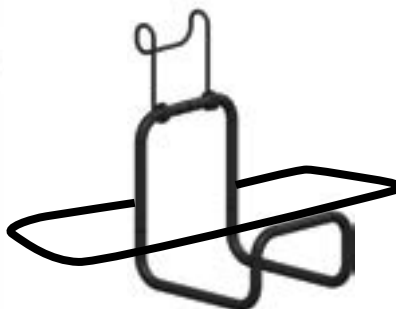

Cooler Adapter



Cooler Bag with Carry Strap



Footrest



Parent Organizer
(Ships inside of Cooler Bag)



Extending Tray

ASSEMBLY

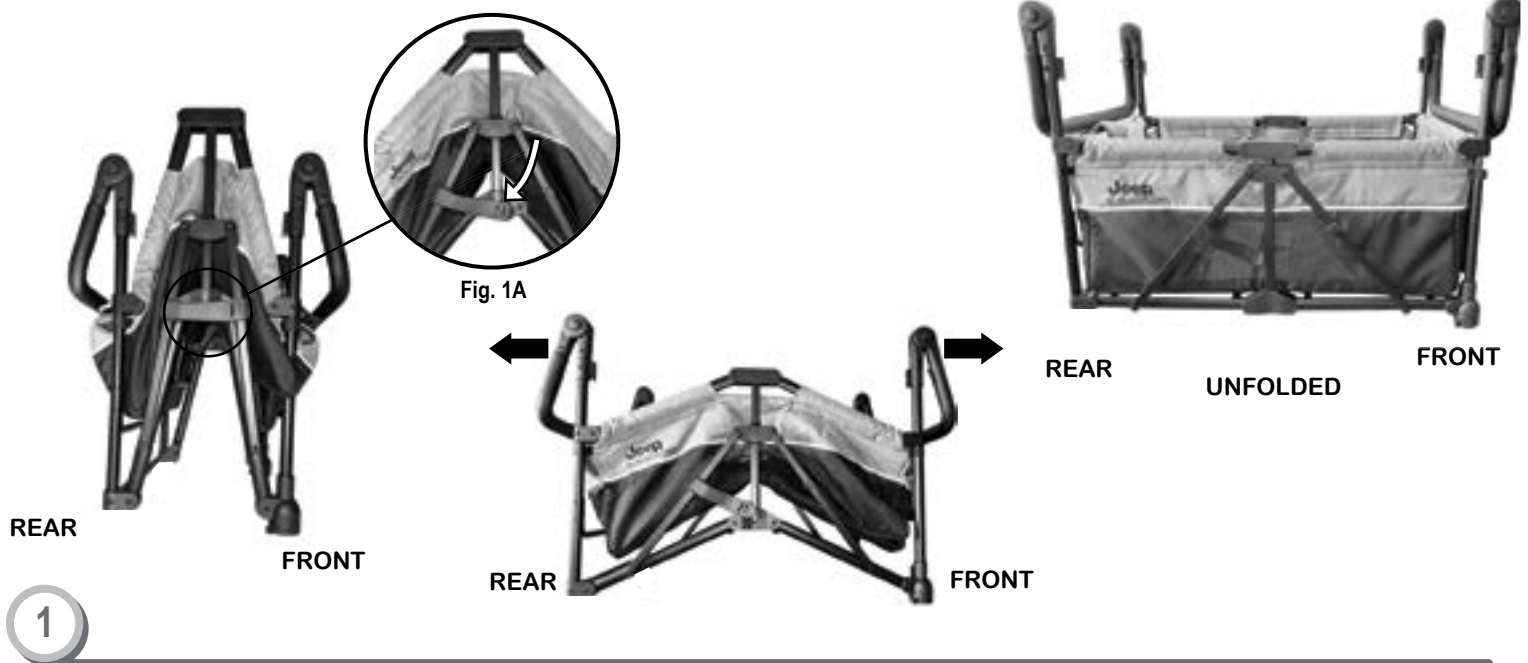

PREPARING WAGON

- Unfolding wagon: Unlatch wagon by pulling latch away from latch post (Fig. 1A).
- After latch is cleared, allow the wagon to unfold out, or manually pull the wagon apart (Fig. 1B)

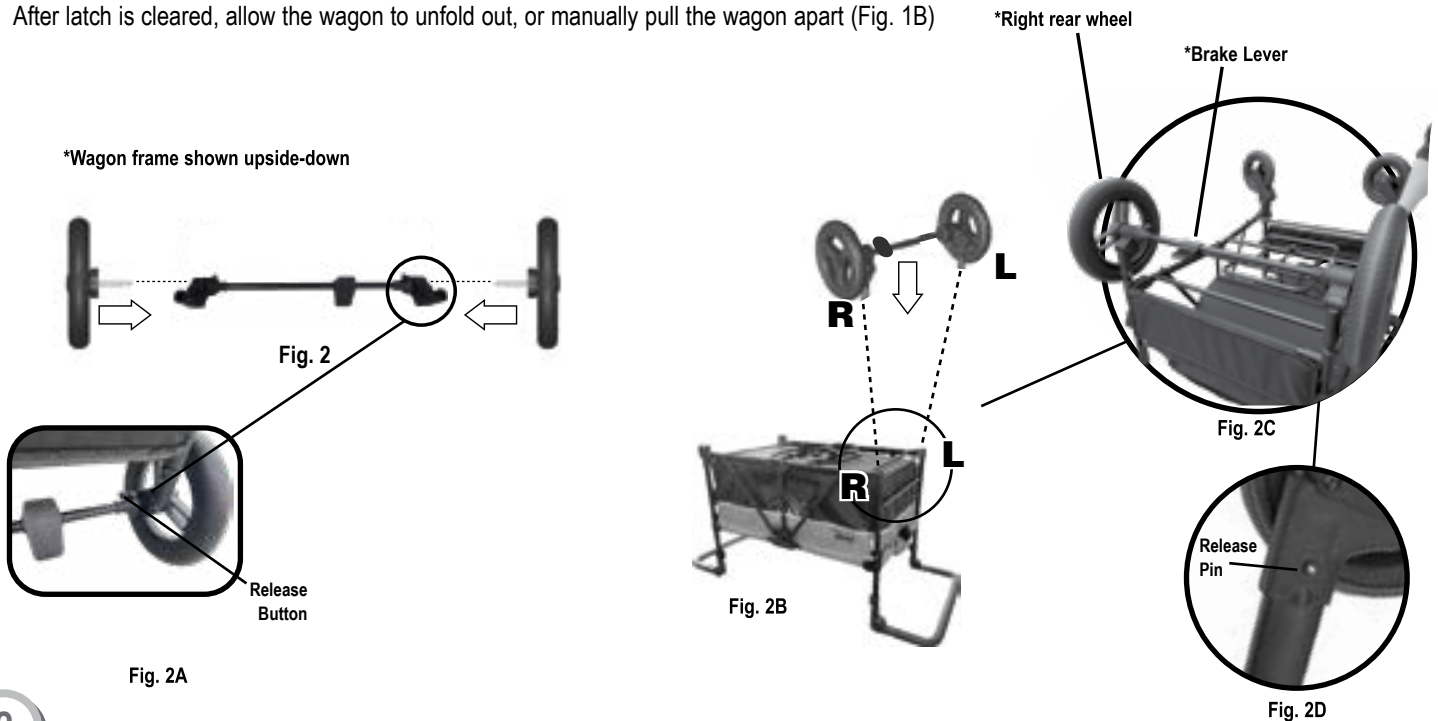

ATTACHING & REMOVING REAR WHEELS

- Attach rear axle connection tubes into rear wheel axle until they “click” into a locked position.
- To attach rear wheels to axle: Push each rear wheel into the axle housing as shown until they “CLICK” into a locked position (Fig. 2).
- Pull outward on wheel to ensure that the wheel is securely locked.
- To release rear wheels from axle: While pressing the release button located on the back of the wheel housing, remove wheel by pulling away from housing (Fig. 2A)

ATTACHING & REMOVING REAR WHEEL AXLE

- To attach rear wheel axle: Align axle with frame as shown and push in until both release pins “CLICK” (Fig. 2B). Make sure that the rear wheels are beneath the wagon frame. Match side L to L and side R to R.
- NOTE: Make sure brake is closest to right rear wheel.
- To detach rear wheel axle: Press in release pins on both outer sides of frame, and pull away from wagon frame (Fig. 2D).

ASSEMBLY

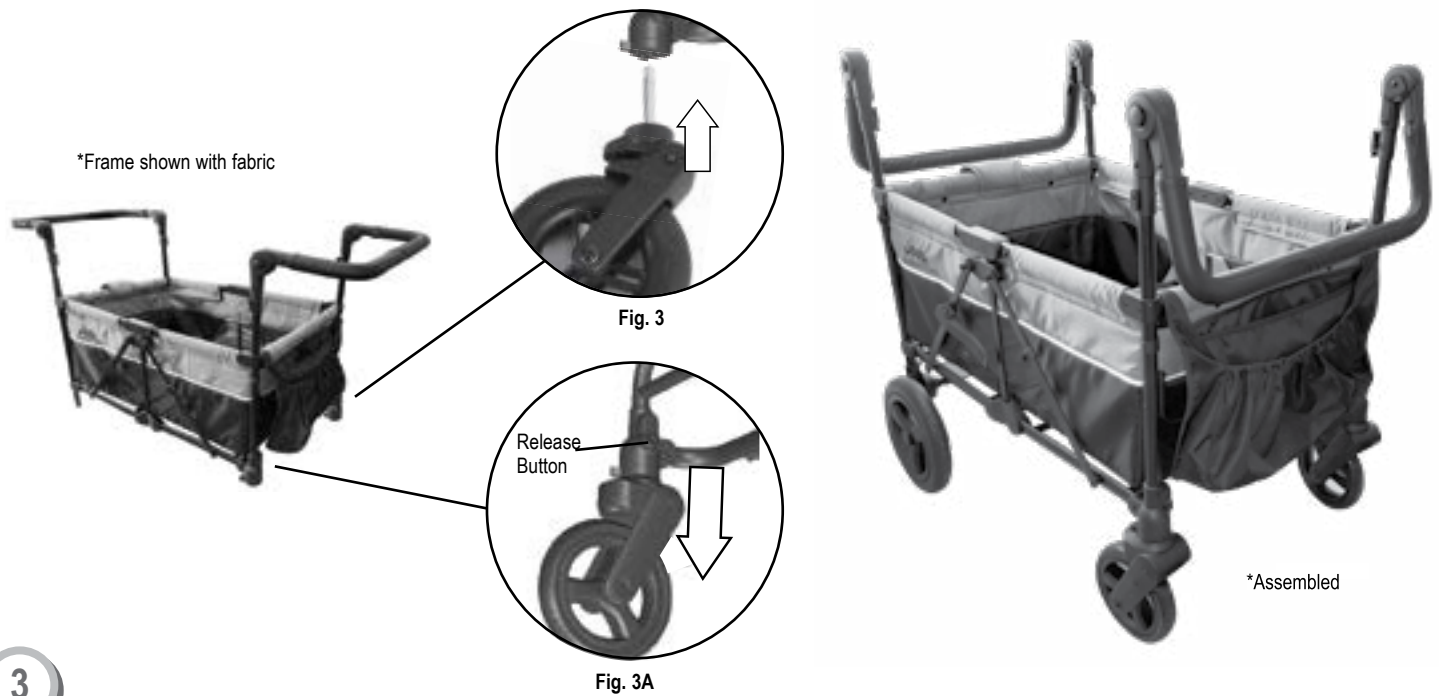

3

ATTACHING & REMOVING FRONT WHEEL

Note: Before attaching wheels, make sure the wagon is in a fully open position.

- To attach front wheel: Push front wheel post into the front wheel housing until it "CLICKS" into a fully locked position. (Fig. 3)
- To release front wheel: Press the release button located on the side of the wheel housing and pull down on wheel to release (Fig. 3A).

Note: Pull downward on wheel to ensure that the wheel is securely locked.

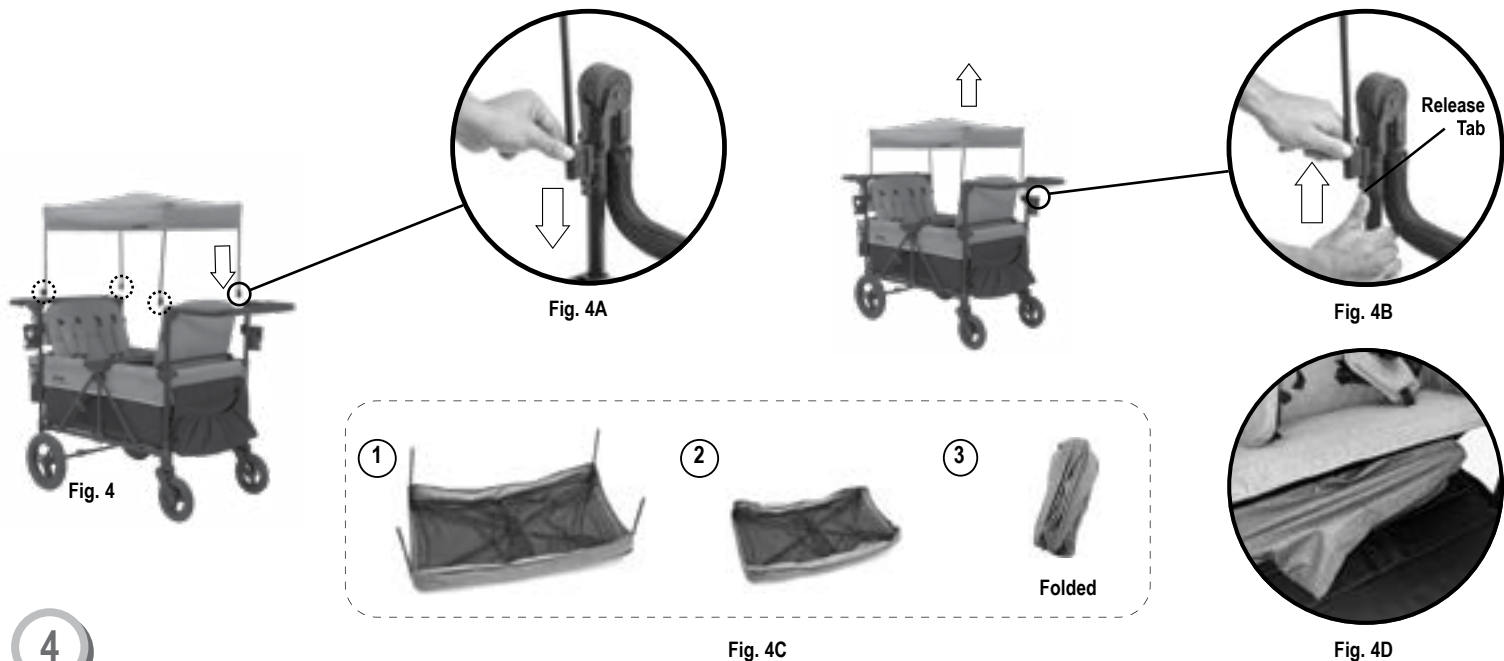

4

ATTACHING & REMOVING CANOPY

- To attach canopy: Align each of the 4 canopy rods with their corresponding posts (Fig 4A).
- Firmly insert each rod into its housing (Fig 4A).
- See (Fig. 4B) for detailed view of canopy post insertion.
- To remove canopy: While release tab is pressed, pull up on each rod until it clears the wagon frame (Fig. 4B).
- Fold canopy by folding each rod, then folding canopy frame closed (Fig. 4C).
- Canopy can be stored in under-seat storage areas (Fig. 4D).

SETUP AND USE



Fig. 2

Fig. 2A

1

WARNING: Always lock brake when the wagon is not being pushed so that the wagon will not roll away. Never leave wagon unattended on a hill or incline as the wagon may slide down.

WARNING: NEVER leave children unattended in wagon.

REAR WHEEL BRAKE LOCK

- To engage brakes: Apply light downward pressure to the brake lever located on the front of the wheel housing. (Fig. 1).
- Check to make sure the brakes are in a fully locked position, making sure stroller will not move when pushed.
- To release brakes: Gently lift the brake lever up. (Fig. 1A).

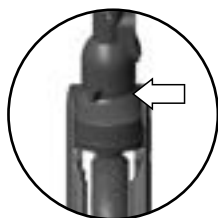

Rotate clockwise to lock

Fig. 3

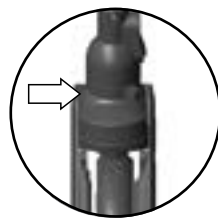

Rotate counter clockwise to unlock

Fig. 3A

3

FRONT WHEEL SWIVEL LOCK

- To lock the front swivel wheel lock: Rotate the lever located on the top of the front wheel housing clockwise until it "CLICKS" into a fully locked position (Fig. 3).
- To unlock the front swivel wheel lock: Rotate the lever located on the top of the front wheel housing counter clockwise until it "CLICKS" into a fully locked position (Fig. 3A)

2

FRONT WHEEL SWIVEL LOCK

- To engage brakes: Apply light downward pressure to the FRONT of the brake lever located on the axle. (Fig. 2).
- Check to make sure the brakes are in a fully locked position, making sure stroller will not move when pushed.
- To release brakes: Apply light downward pressure to the BACK of the brake lever (Fig. 2A).

Fig. 4

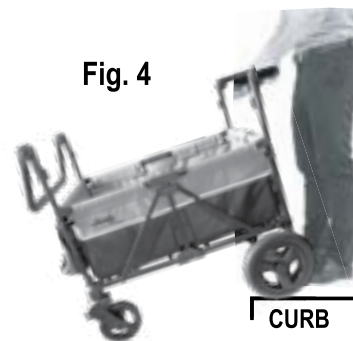

CURB

4

CLEAR WAGON OVER SIDEWALKS AND CURBS

- To clear wagon over sidewalks and curbs: Lift wheels using the REAR handlebars and PULL over the sidewalk or curb from a backwards position (Fig. 4).

WARNING: Please do not attempt to push down on rear handlebars to lift front wheels.

SETUP AND USE

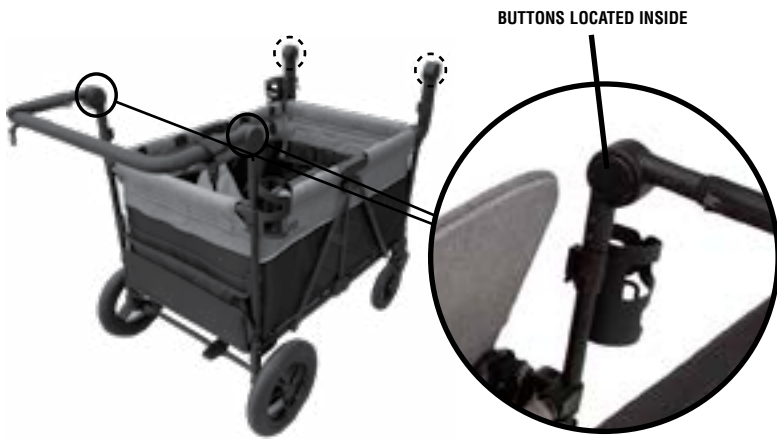

Fig. 5



Fig. 5A

4

ADJUSTING HANDLEBARS

- To adjust handle: Press BOTH buttons (located on either side, inside of handlebar) (Fig. 5).
- With both buttons pressed, rotate the handle up or down to desired position (Fig. 5A).
- The buttons will “CLICK” on both sides once it is in a fully locked position.
- Confirm both buttons are depressed and handlebars are in a locked position before use.

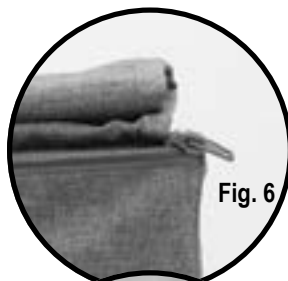

Fig. 6



Fig. 6A



Fig. 6B



Fig. 6C

6

ADJUSTING CANOPIES

- To use sun shade: Locate zipper at the top of the canopy (Fig. 6).
- Unzip to reveal sunshade and carefully roll down (Fig. 6A).
- Use magnet attachments to firmly secure to wagon (Fig. 6C).
- To store sun shade: Detach sunshade from magnet attachment points (Fig. 6B).
- Carefully roll the sun shade up so that it fits in storage compartment as originally stored, and zip to enclose (Fig. 6A).

SETUP AND USE

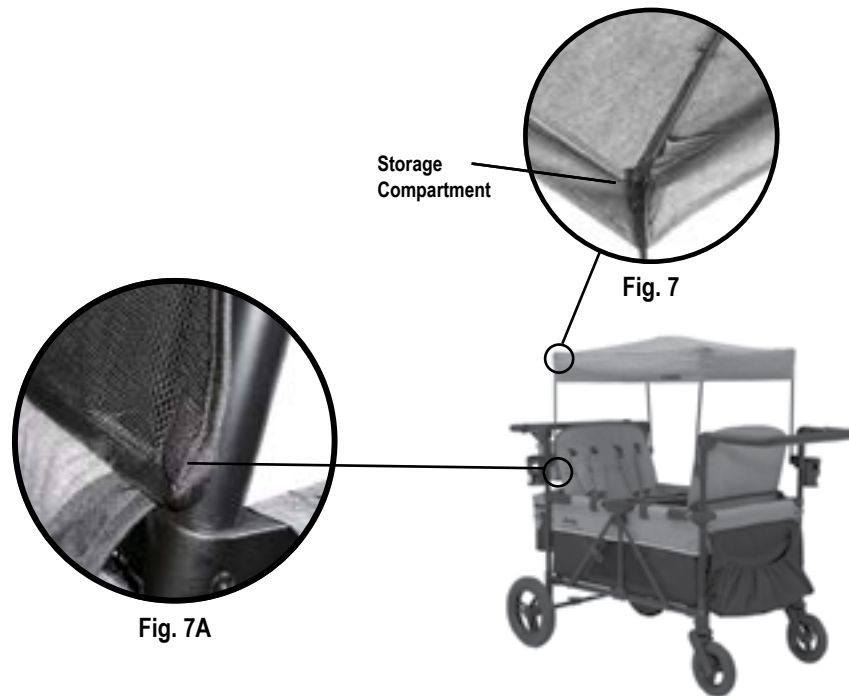

7

USING MESH NET

- To use mesh net: Locate the mesh net in the storage compartment directly underneath the canopy at the front and rear of the wagon (Fig. 7).
- Remove mesh from storage compartment and roll down.
- Secure mesh to each side of the frame of the wagon using magnets (Fig. 7A).
- To store mesh net: Unfasten magnet from frame of wagon.
- Roll mesh net evenly towards the top of the wagon.
- Store in the storage compartment on the inside of the canopy (Fig. 7).

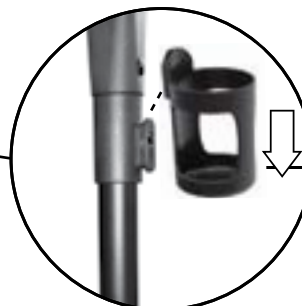

Fig. 8A



Fig. 8B

8

POSITIONING CUP HOLDER

NOTE: Cup holder can be positioned in one of the two posts on the wagon frame. (Fig.8).

- To install cup holder: Align clip on cup holder with frame post and apply downward pressure until it 'SNAPS' into place (Fig. 8A).
- To remove cup holder: Apply upwards pressure until cup holder releases from post (Fig. 8B).

SETUP AND USE

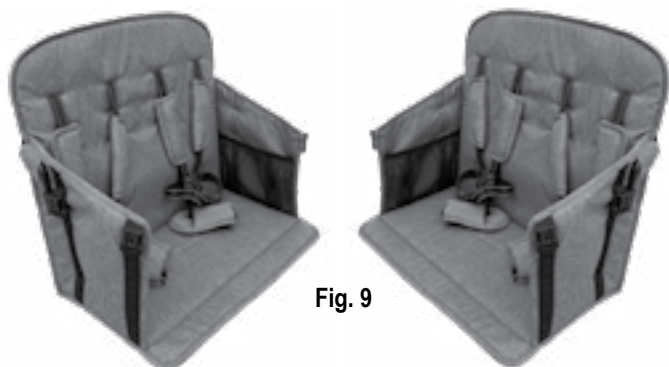

Fig. 9

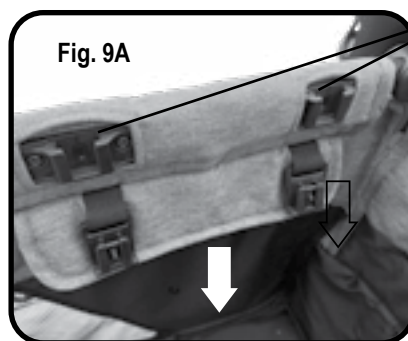

Fig. 9A

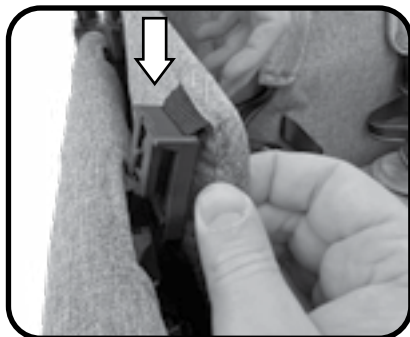

Fig. 9B

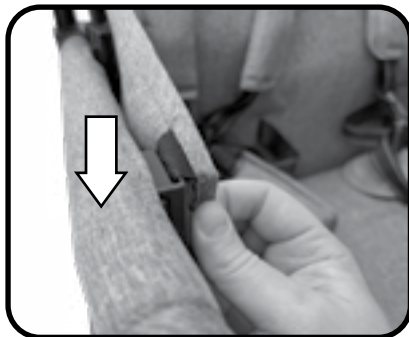

Fig. 9C



Fig. 9D



9

INSTALLING SEATS

- Seats can hold up to two children each. (Fig. 9).
- Secure seats to frame. Make sure to use both sides to attach securely.
- Harnesses can be removed from seats and installed directly into wagon liner. SEE STEP 11 FOR INSTALLING HARNESS IN WAGON.
- Locate the open slots on either side of the wagon. There is a set on both the front and the back. (Fig. 9A)
- With the seat oriented in the desired location and direction, insert clip into slot as shown (Fig. 9B) Repeat for other 3 clips on seat. Then

repeat on second seat if desired.

- Push down on each clip until they lock into place. (Fig. 9C).
- Make sure clips are fully secure before seating children in seats. (Fig. 9D)

WARNING: Harnesses should always be used when child is seated in wagon.

SETUP AND USE



Fig. 10



Fig. 10B



Fig. 10A



Fig. 10C

10

SEATING CONFIGURATIONS

- Seats can face each other (Fig. 10).
- Seats can face forward (Fig. 10A), or backward (Fig. 10B).
- Seats removed, harnesses can be used in wagon without seats.
- Seats can face opposite directions with open wagon (Fig. 10C). SEE STEP 11 FOR LOWERING BAR FOR OUTWARD FACING SEATING.



Fig. 11



Fig. 11A



Fig. 11B

11

WHEN SEATS ARE NOT IN USE APPLY PADDED SLOT COVERS

- Locate vacant slots – The same slots the seat clips use – And the attached covering (Fig. 11).
- Insert covering clips as show (Fig. 11A). Push down until covering clips lock into place.
- Fully installed covering protects and pads clips (Fig. 11B)

SETUP AND USE



Fig. 12

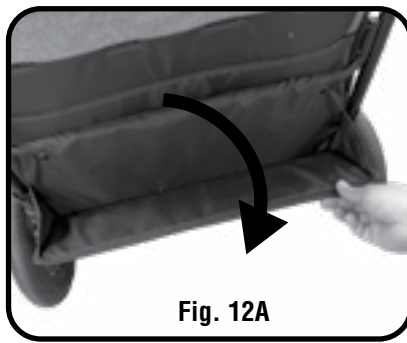

Fig. 12A

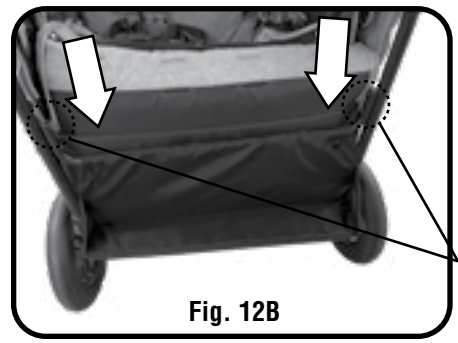

Fig. 12B

ZIPPERS

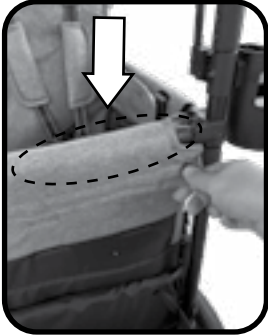

Fig. 12C



Fig. 12D



Fig. 12E



Fig. 12F



Fig. 12G



⚠ WARNING:

**DO NOT USE AS A
STEP INTO THE SEAT**

12

USING FOOTREST WHEN SEAT IS IN OUTWARD FACING POSITION

- Locate the folded up footrest. They can be found on the lower portion of both the front and back of the wagon. (Fig. 12)
- Fold footrest down. (Fig. 12A) If using both sides, repeat.
- Undo the zippers on both sides above the footrest. (Fig. 12B)
- At the top of the frame locate the crossbar. (Fig. 12C)
- At each end of the crossbar, there is spring-loaded plastic fitting. Pull back on the fitting as shown in Fig. 12D, Repeat on other side and pull out crossbar. (Fig. 12E)
- Holding onto the cross bar, tuck it and attached fabric into the space between the edge of the seat and the frame and frame covering. (Fig. 12F)
- Smooth out fabric and foot rest is now ready to use. (Fig. 12G)
- **WARNING:** Harnesses should always be used when child is seated in wagon.

SETUP AND USE



Fig. 11

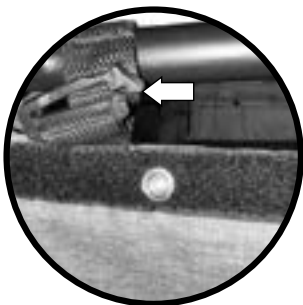

Fig. 11A



Fig. 11B



Fig. 11C



Fig. 11D

11

SETTING UP FOR OUTWARD FACING SEATING

- Open velcro securing fabric to frame.
NOTE: If opening end where storage bag is located, zip off the storage bag first (Fig. 11).
- Slide out clips from straps on each side (x2) (Fig. 11A).
- Zipper down each side (x2) (Fig. 11B).
NOTE: Zippers only go down half way.

- Fold fabric around bar, and button into place (x2) (Fig. 11C).
- Place seat facing forward, feet will hang over front (Fig. 11D).

WARNING: Harnesses should always be used when child is seated in wagon.



Fig. 12

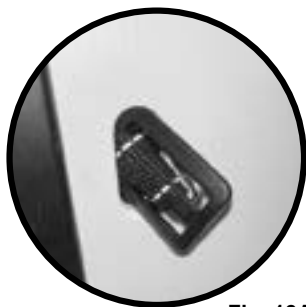

Fig. 12A

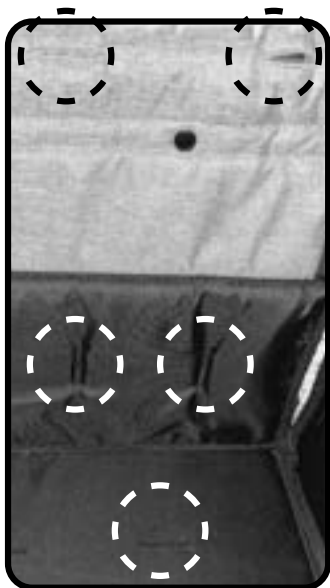

Fig. 12B

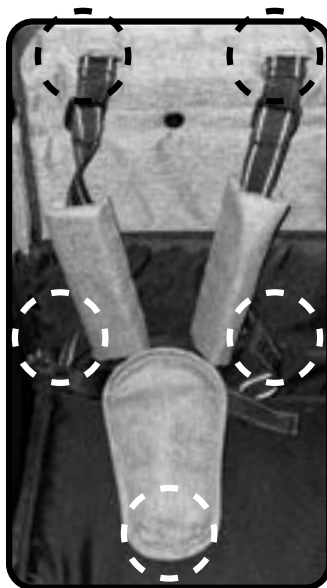

Fig. 12C

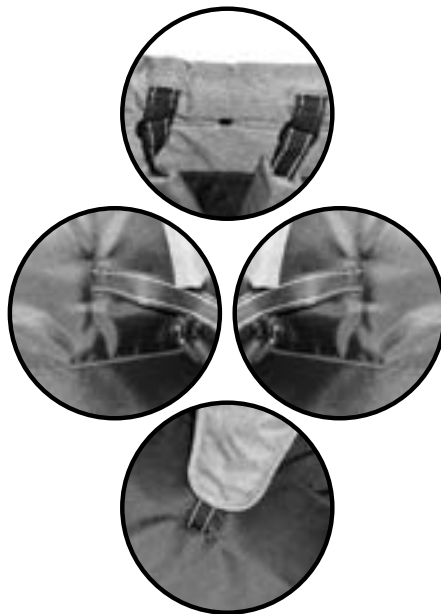

Fig. 12D

12

USING HARNESS IN WAGON WITHOUT SEATS

- Open velcro securing fabric to seat. pull back fabric (Fig. 12).
- Slide out tabs to release straps (Fig. 12A). Release each harness point.
- Locate 5 harness points on wagon (Fig. 12B). There are 4 locations (2 on each end) where harness can be attached.
- Insert tabs for each harness to slots in desired location (Fig. 12C).

- Make sure each harness point is securely fastened (Fig 12D).
- Pull on each point to test. If tab is loose or comes out resecure into place.

WARNING: Do not use if harness is not secure.

SETUP AND USE

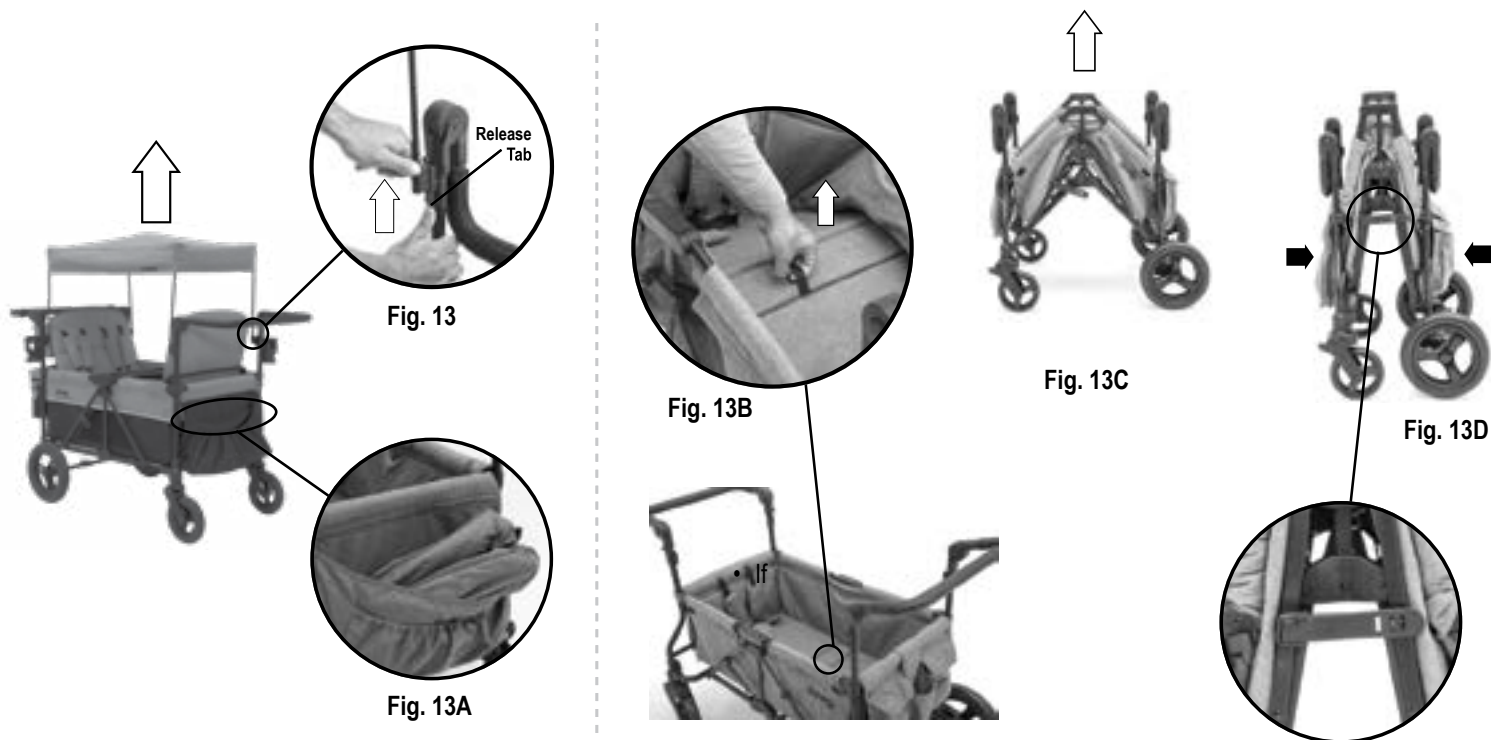

13

FOLDING WAGON FOR STORAGE

- If canopy installed: Uninstall by pressing release tab and pulling up on each rod until it clears the wagon frame (Fig. 13).
NOTE: Folded canopy can be stored in front storage compartment (Fig. 13A).
- If seats installed: Remove straps from back of seat. Pull clips to detach from frame. Fold and store.
- To fold wagon frame: Locate handle in center of wagon seat pad (Fig. 13B) and pull upward until wagon frame begins to fold (Fig. 13C).
- To finish the fold, apply pressure inwards until wagon is fully closed and auto latch “CLICKS” (Fig. 13D).
- Pull outwards on wagon to confirm latch is secured.
- Fold seats and slide into each end of folded wagon to store (Fig. 13E).
- Store cup holders, connect tubes & parent organizer into cooler bag. (Fig. 13F).



SECURING CHILD

Before Placing your Child in Stroller:

Close Canopy. Press both brake pedals down until they “click” into the lock position.

Make sure the brake pedals are pressed down completely.

Always set both brake pedals when parking the stroller.

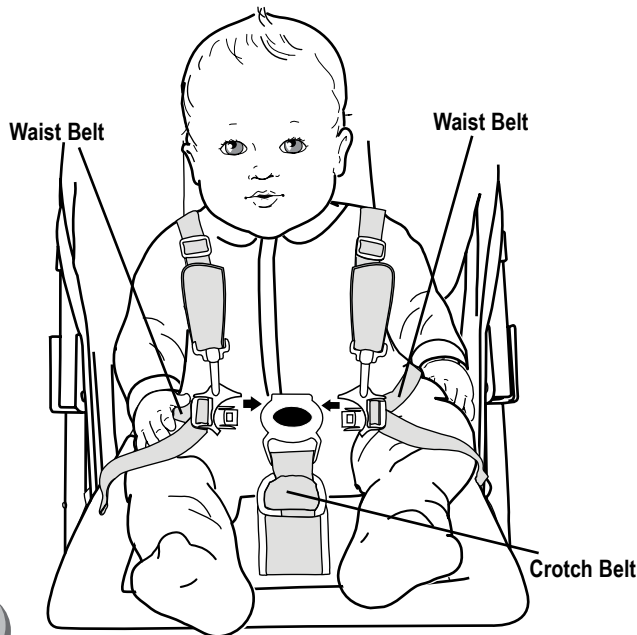

1

Securing Child

- Place your child in the stroller. Position the crotch belt between your child’s legs.
- Pull shoulder straps over child’s arm and shoulder and fasten both strap ends to the restraint system.
- Fasten both waist belts to the buckle on each side of the crotch belt. Make sure you hear a “click” on both sides.
- Check to be sure the restraint system is securely attached by pulling it away from your child. The restraint system should remain attached.



2

- Tighten each waist belt and shoulder strap so that the restraint system is snug against your child.

Please refer to the next section for instructions to tighten the waist belts.

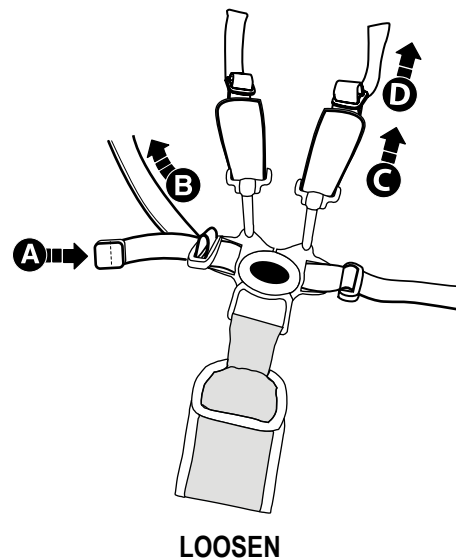
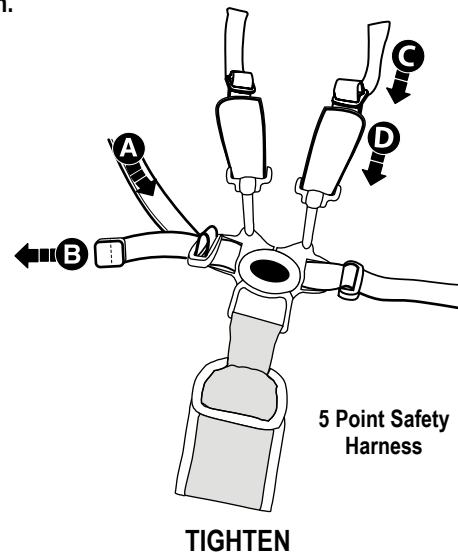

3

To tighten the waist belts and shoulder straps:

- Feed the anchored end of a waist belt up through the buckle to form a loop **A**. Pull the free end of the waist belt **B**.
- Repeat this procedure to tighten the other waist belt.
- Feed the top end of the shoulder strap through the plastic stay to form a loop **C**. Pull the bottom end down to tighten the strap **D**.
- Repeat this procedure to tighten the other shoulder strap.

To loosen the waist belts and shoulder straps:

- Feed the free end of the waist belt up through the buckle to form a loop **A**. Enlarge the loop by pulling on the end of the loop toward the buckle. Pull the anchored end of the waist belt to shorten the free end of the waist belt **B**.
- Repeat this procedure to loosen the other waist belt.
- Feed the bottom end of the shoulder strap through the plastic stay to form a loop **C**. Pull the top end up to loosen the strap **D**.
- Repeat this procedure to loosen the other shoulder strap.

Please Note: After adjusting the restraint system to fit your child, make sure you pull on it to be sure it is securely fastened.

CLEANING AND MAINTENANCE

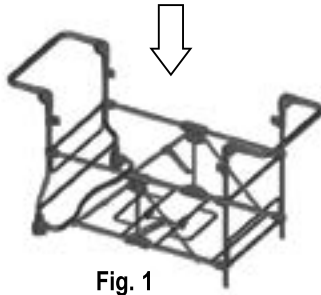

Fig. 1

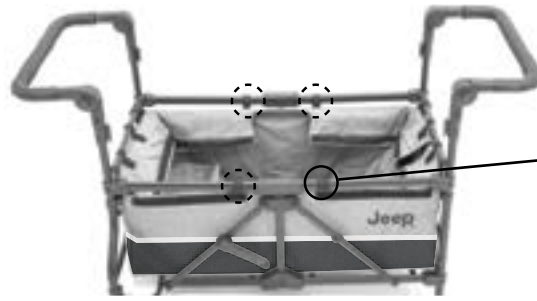

Fig. 1A

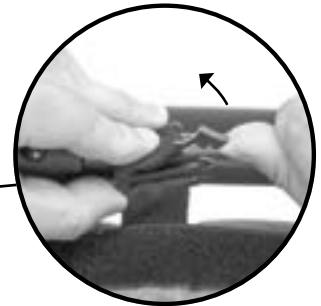

Fig. 1B



Fig. 1D

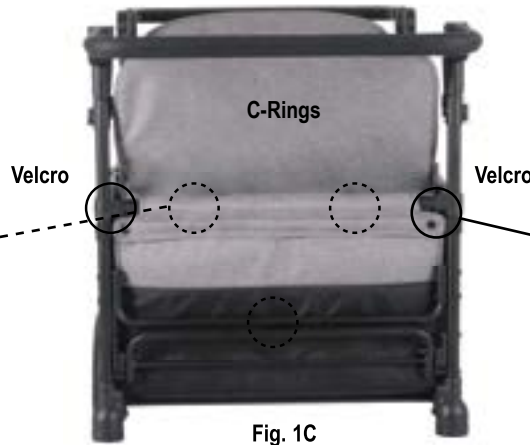
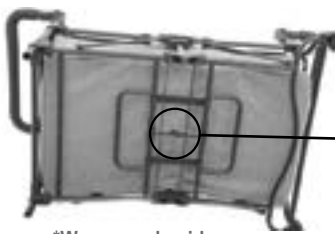

Fig. 1C
Front & Rear view



*Wagon underside



Fig. 1F



FRONT & REAR



ALL SIDES

Fig. 1G

1

INSTALLING & REMOVING FABRIC LINER FROM WAGON FRAME

- Installing fabric liner: Start by inserting fabric liner as shown with all flaps inside (Fig. 1).
- Attaching buckle straps: Locate the 4 buckle straps on the sides of fabric liner (Fig. 1A).
- Place each strap over wagon frame and use finger tip to pull buckle open. While buckle is open, feed strap through and release finger from clip to secure. Repeat for all 4 buckles (Fig. 1B).
- Attaching C-ring straps: Locate the 7 C-rings (3 front, 3 rear, 1 under) on front, rear and underside of fabric liner (Fig. 1C, Fig. 1F).
- Place each strap over the wagon frame and secure by pulling strap through the slit at the bottom of the C-ring (Fig. 1D). Do the same for wagon underside but attach to center of frame (Fig. 1F).
- Attaching velcro straps: Locate the 4 velcro (2 front, 2 rear) straps on the front and rear of fabric liner (Fig. 1E).
- Secure velcro straps by placing around wagon frame as shown (Fig. 1E).
- Finish by securing fabric liner velcro attachments as shown (Fig. 1G). On Front and back velcro, snap both buttons on both sides.
- To remove fabric liner from wagon frame: Follow these steps in reverse.

CLEANING AND MAINTENANCE

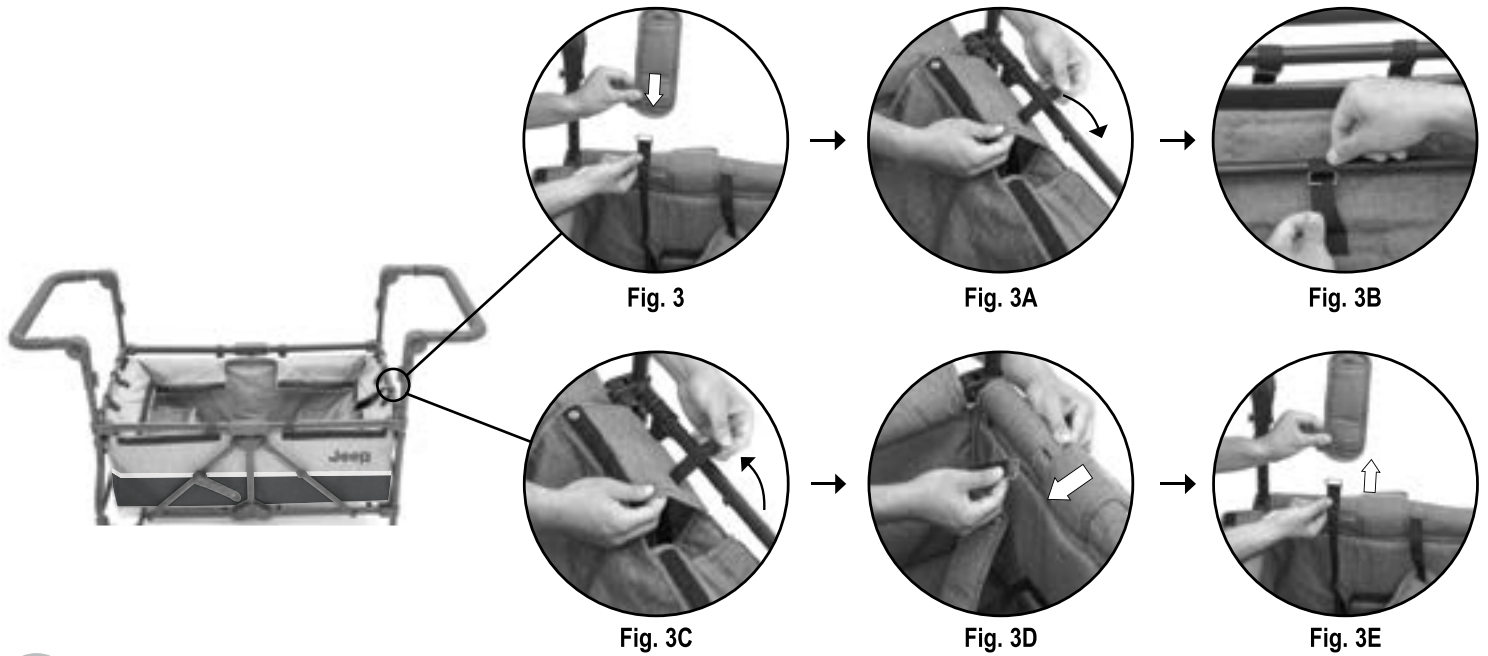

2

INSTALLING & REMOVING SHOULDER STRAPS FOR CLEANING

- To install shoulder straps: Slide shoulder strap fabric onto C-ring strap (Fig. 3)
- Slip C-ring strap through slit in fabric liner (Fig. 3A).
- Secure by placing strap over the wagon frame and pulling strap through the slit at the bottom of the C-ring (Fig. 3B).
- To remove shoulder straps: Remove C-ring strap by pulling strap through slit and removing (Fig. 3C)
- Remove strap from fabric liner slit (Fig. 3D)
- Remove shoulder strap fabric from harness by sliding up and off (Fig. 3E)

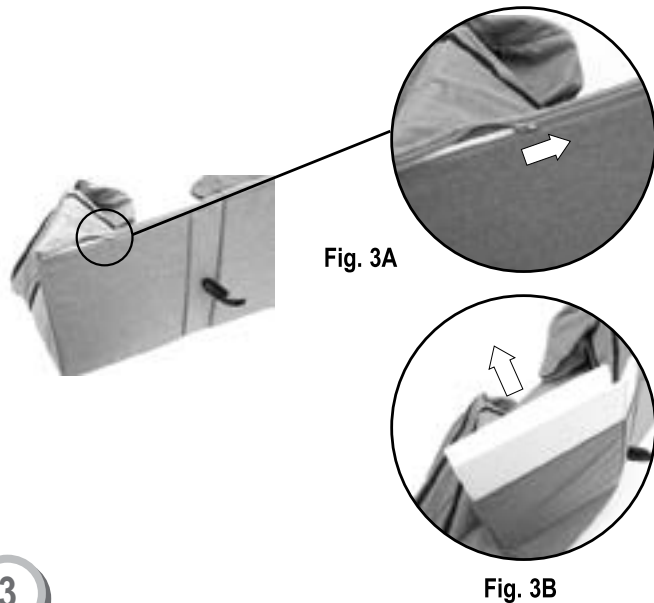

3

REMOVING SEAT PAD FOR CLEANING

- Use earlier instructions on pg. 12 to remove fabric liner from frame.
- Locate zipper at the bottom edge of fabric (Fig. 3A).
- Unzip to remove foam and board (Fig. 3B).
- To replace, follow these steps in reverse.

ASSEMBLING COOLER ADAPTER

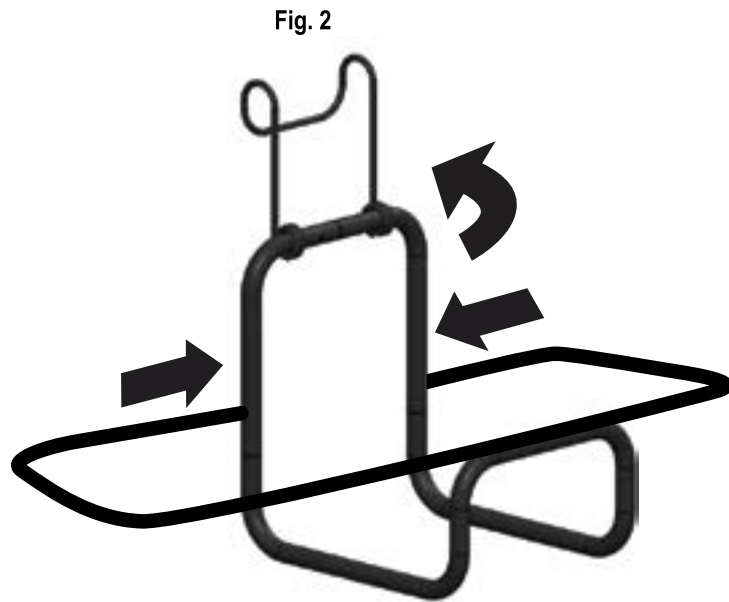
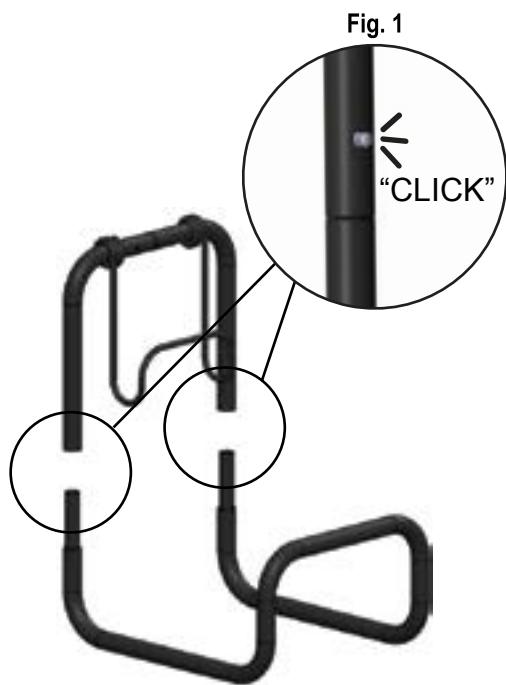

1

ATTACHING BOTTOM BASE TO SIDE FRAME ASSEMBLY

- To attach bottom base to the side frame assembly, insert the bottom base to the ends of the side frame until it "CLICKS" into place (Fig. 1).

NOTE: Pull outward on the bottom base to ensure it is fully fastened.

ATTACH COOLER OUTER FRAME

- Clip both ends of outer frame to holes in main frame. Push in to secure.

2

ROTATING CLIP

- To complete the assembly, rotate the clip of the adapter until it is fully upright (Fig. 2).

ATTACHING COOLER & ADAPTER

! WARNING !

WARNING: THE MAXIMUM WEIGHT THAT CAN BE CARRIED IN THE COOLER BAG IS 15 POUNDS (6.8KG).
CAPACITY: CAN HOLD A 10 POUND (4.5KG) BAG OF ICE (ONLY) & 16 (12OZ) CANS OF SODA.



Fig. 3



Fig. 3A

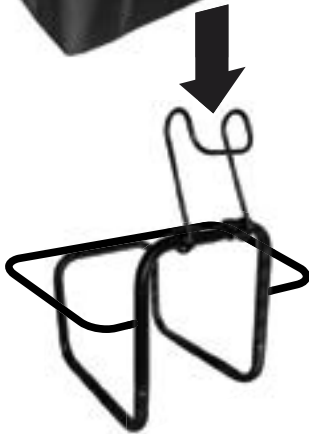

3

ATTACHING COOLER TO COOLER ADAPTER

- To attach cooler to cooler adapter, locate the back strap behind cooler and slide it over the cooler adapter hooks to secure in place (Fig. 3).
- Fully assembled cooler to cooler adapter (Fig. 3A).



Fig. 4

*Assembled

4

ATTACHING COOLER ASSEMBLY TO WAGON FRAME

- To attach cooler assembly to wagon frame, locate the metal hooks on back of cooler and attach to the top rail of wagon (Fig. 4).

ATTACHING COOLER & ADAPTER

! WARNING !

WARNING: THE MAXIMUM WEIGHT THAT CAN BE CARRIED IN THE PARENT ORGANIZER IS 3 LBS (1.4KG).



Fig. 5



Fig. 5A

5

ATTACHING PARENT ORGANIZER TO WAGON FRAME

- Wrap straps around each bar leading to handle, fasten both sides(x2) (Fig 5).
- Adjust straps to desired height on wagon and to level (Fig 5A).

ATTACHING EXTENDING TRAY



Fig. 6



Fig. 6A



6

ATTACHING EXTENDING TRAY TO WAGON FRAME

- Extend tray over each 'Jeep' Connector on sides of wagon (Fig 6).
- Push down on each side until tray 'clicks' into place (Fig 6A).

DELTA♥CHILDREN

Delta Children's Products Corp.
114 West 26th Street
New York, NY 10001
gcs@DeltaChildren.com
www.DeltaChildren.com

follow us



@deltachildren