

DELTA♥CHILDREN™ Dresser With Changing Top

Read all instructions before assembly and use.

KEEP INSTRUCTIONS FOR FUTURE USE.



To Make Assembly Even Easier Watch Video Here!



For Questions or to Contact Us:

DeltaChildren.com/Help

If unable to access website, please email wcs@DeltaChildren.com

Expect longer response times via email.

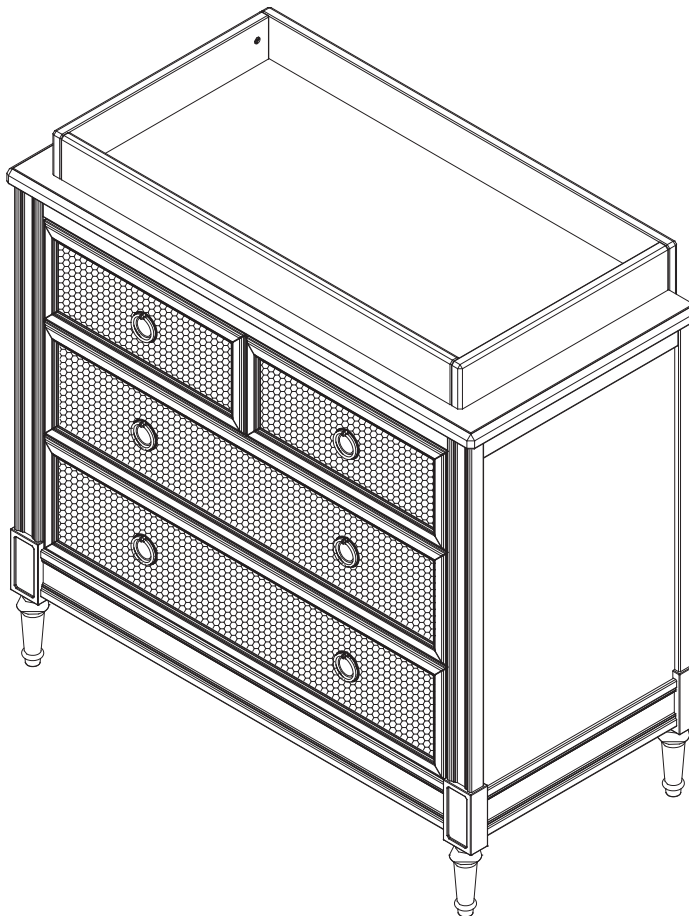

sample tested to meet U.S. Federal, ASTM and other safety requirements

Style #: _____
 [A] Lot: _____
REV
 Date: _____

Before contacting Delta Consumer Experience Center please ensure this information matches the information found on the label on the Back Panel.



ADULT ASSEMBLY REQUIRED

Due to the presence of small parts during assembly, keep out of reach of children until assembly is complete.

This product is not intended for institutional or commercial use.

DELTA♥CHILDREN™ **Cómoda con el cambiador**

Lea todas las instrucciones antes de ensamblar y usar.

MANTENGA LAS INSTRUCCIONES PARA SU USO FUTURO.

ES

Para facilitar más aun el ensamblaje ver el video aquí

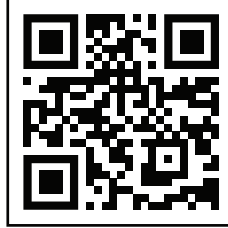

Para preguntar o para contactarnos :

DeltaChildren.com/Help
Si no puede acceder el sitio web, por favor envíenos un email a wcs@DeltaChildren.com
El tiempo de espera para respuestas será más largo por email.

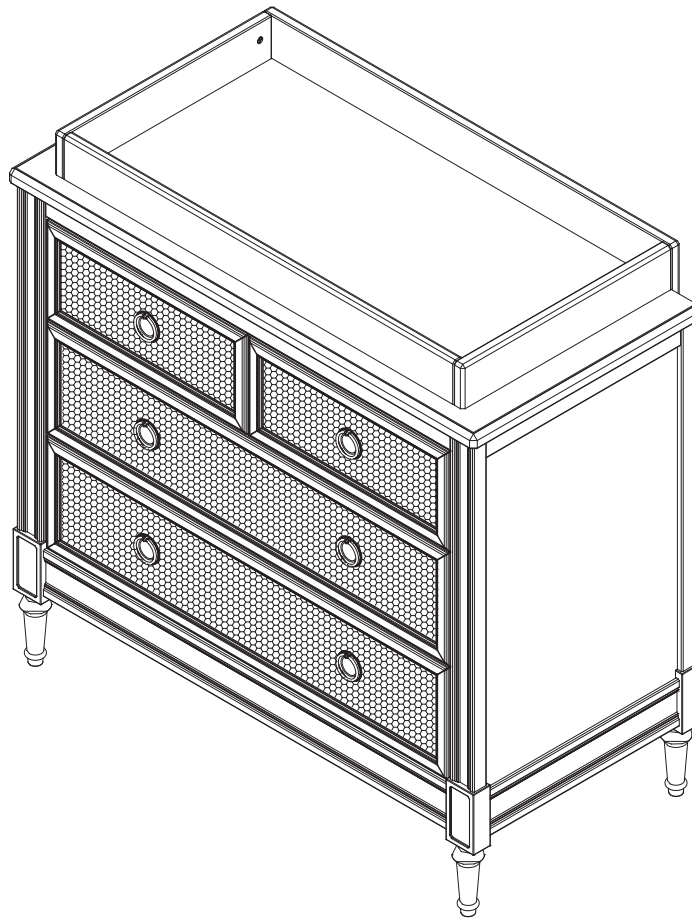

sample tested to meet U.S. Federal, ASTM and other safety requirements

Antes de contactar el Centro de Experiencia del Consumidor de Delta por favor asegúrese de que la información de la primera página coincida con la información que se encuentra en la etiqueta ubicada en el panel trasero.



DEBE SER ENSAMBLADO POR UN ADULTO

Debido a la presencia de piezas pequeñas durante el ensamblaje, mantenga fuera del alcance de los niños hasta que complete el ensamblaje.

Este producto no esta hecho para uso institucional o comercial.

BABY SAFE SLEEP TIPS

Visit Deltachildren.Com/Pages/Crib-Safety-Tips for more information



Read all warnings and follow all instructions.



DO NOT place any items in the crib.



The safest place for your baby to sleep is in a JPMA Certified crib.



Pillows and blankets have caused infants to suffocate, **NEVER** use in a crib.

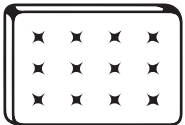

Your baby should sleep on a firm mattress.



NEVER place the crib near a window or any wall hangings.



Adult beds are not safe for babies: **NEVER** co-sleep.



Missing or broken parts, any questions?
www.DeltaChildren.com/Help



AAP RECOMMENDS:

Always lay your baby on its back to sleep.

Consult your doctor.

FURNITURE SAFETY TIPS

Visit [DeltaChildren.Com/Pages/Leaders-In-Safety](https://www.DeltaChildren.com/Pages/Leaders-In-Safety) for more information

SERIOUS OR FATAL CRUSHING INJURIES
CAN OCCUR FROM FURNITURE TIP-OVER.



Read all warnings and follow all instructions.



NEVER open more than one drawer at a time.



ALWAYS use provided tipover restraints.



DO NOT leave drawers open when not in use.



DO NOT set TV's or other heavy objects on the top of bedroom or nursery furniture.



NEVER allow children to climb or hang on drawers, doors, or shelves.



Place heaviest items in the lowest drawers.



Missing or broken parts, any questions?

www.DeltaChildren.com/Help

CONSEJOS PARA UN SUEÑO SEGURO PARA LOS BEBÉS

Visite Deltachildren.Com/Pages/Crib-Safety-Tips para obtener más información



Lea todas las advertencias y siga todas las instrucciones.



NO coloque artículos en la cuna.



El lugar más seguro para que su bebé duerma es una cuna con certificación JPMA.



Las almohadas y frazadas han provocado asfixia en menores; por lo tanto, **JAMÁS** se deben utilizar en una cuna.



Su bebé debe dormir sobre un colchón firme.



JAMÁS coloque la cuna cerca de una ventana o elementos colgados en las paredes.



Las camas para adultos no son seguras para los bebés: **JAMÁS** duerma con ellos.



¿Le faltan piezas o vienen rotas?
www.DeltaChildren.com/Help



APP RECOMIENDA:

Haga que su bebé duerma siempre boca arriba.

Consulte a su médico.

CONSEJOS DE SEGURIDAD SOBRE MUEBLES

Visite Deltachildren.Com/Pages/Leaders-In-Safety para obtener más información

**PUEDEN PRODUCIRSE LESIONES GRAVES O MORTALES
POR APLASTAMIENTO AL VOLCARSE MUEBLES.**



Lea todas las advertencias y siga todas las instrucciones.



NUNCA abra más de un cajón al mismo tiempo.



Utilice **SIEMPRE** las retenciones contra volcamiento incluidas



NO DEJE cajones abiertos si no los está utilizando.



NO posicione televisores u otros objetos pesados sobre la cama o muebles para infantes.



NUNCA permita que los niños trepen sobre cajones, puertas o baldas de estantería ni que se cuelguen de ellos.



Coloque los artículos de mayor peso en los cajones inferiores.



¿Le faltan piezas o vienen rotas?
www.DeltaChildren.com/Help

SAVE BIG WITH DELTA CHILDREN

Visit **Deltachildren.com** To Start Shopping

Welcome to the
DELTA FAMILY
Here's a Gift From Us To You

10% OFF

Your Next Purchase From
DeltaChildren.com

**USE CODE:
DELTA10**

*Exclusions Apply
*Subject to Change

REVIEW TO WIN \$2500

RULES TO ENTER

★ ★ ★ ★ ★

"We LOVE, LOVE, LOVE this crib"

My husband was impressed with the directions and organization of the hardware package. He easily assembled this crib in an hour without any help. It's very sturdy and we like that it has adjustable levels for the mattress height. To top it all off, it's so incredibly darling!!!

- 1 WRITE A REVIEW** for this product on the store's website from where it was purchased
- 2 TAKE A SCREENSHOT** of your review and upload it to www.DeltaChildren.com/Review
- 3 IT'S THAT EASY!** Upon submission, you'll be instantly **ENTERED TO WIN \$2,500**

FOLLOW US FOR MORE CHANCES TO WIN

@deltachildren

SCAN HERE



For more information & to see all of our products

AHORRE MUCHO CON DELTA CHILDREN

Visita **Deltachildren.com** Para Comenzar A Comprar

Bienvenido a la
FAMILIA DELTA
Aquí Está Nuestro Regalo
Para Usted

**10%
OFF**

Su Próxima Compra En
DeltaChildren.com

UTILICE EL CÓDIGO:
DELTA10

*Exclusions Apply
*Subject to Change

CALIFIQUE EL PRODUCTO PARA **GANAR \$2500**

REGLAS PARA PARTICIPAR



- 1 CALIFIQUE EL PRODUCTO** en la página web de la tienda donde haya sido comprado
- 2 HAGA UNA CAPTURA DE PANTALLA** de su calificación y cárguela a la pagina www.DeltaChildren.com/Review
- 3 ES ASÍ DE FÁCIL!** En cuanto lo envíe ya estará instantáneamente **PARTICIPANDO PARA GANAR \$2.500**

SÍGANOS PARA TENER MAS CHANCES DE GANAR

@deltachildren

ESCANEE AQUÍ



Para más
información
y para ver todos
nuestros productos

⚠ WARNING

Children have died from furniture tipover. To reduce the risk of furniture tipover:

- ALWAYS install anti-tip device provided.
- NEVER put a TV on this product.
- NEVER allow children to stand, climb or hang on any drawers, doors, or shelves.
- NEVER open more than one drawer at a time.
- DO NOT defeat or remove the drawer interlock system, it is an important stability and safety system.
- Place heaviest items in the lowest drawers.

**NOTES ON ASSEMBLY:**

- During the assembly process whenever using screws or bolts, check each by placing the screw/bolt on the diagram of the item which is drawn actual size and design. Be sure to use the proper size and shape specified in the instructions.
- To assemble this unit you may be required to place the unit on it's side and face. It is strongly recommended that assembly is done on a soft, non-abrasive surface to avoid damaging the finish.

NOTES ON USE:

Keep children and others safe by following these simple rules:

- **Do not** allow any child to play on furniture
- **Do not** allow climbing on any piece of furniture.
- **Do not** allow hanging from any piece of furniture.
- Always monitor your child's activity when in the nursery.

NOTES ON CARE AND MAINTENANCE:

- **Do not** scratch or chip the finish.
- Inspect the product periodically, contact Delta Children's Products for replacement parts or questions.
- **Do not** store the product or any parts in extreme temperatures and conditions such as a hot attic or a damp, cold basement. These extremes can cause a loss of structural integrity.
- To preserve the luster of the high quality finish on your product, it is recommended to place a doily or felt pad under any items you place on the finish.
- Clean with a damp cloth, then a dry cloth to preserve the original luster and beauty of this fine finish.
- Do not** use abrasive chemicals.
- Do not** spray cleaners directly onto furniture.
- Lift slightly when moving on carpeting to prevent leg breakage.
- Use of a vaporizer near furniture will cause wood to swell and finish to peel.

⚠ ADVERTENCIA



**Niños han muerto por el volcamiento de muebles.
Para reducir el riesgo de volcamiento de muebles:**

- .SIEMPRE instale el dispositivo antivuelco proporcionado.
- .NUNCA coloque un televisor sobre este producto
- .NUNCA permita que los niños se paren, trepen o se cuelguen de las gavetas, puertas o estantes
- .UNCA abra más de una gaveta al mismo tiempo.
- .NO trate de desactivar o quitar el sistema de bloqueo de la gaveta, es un sistema de estabilidad y seguridad muy importante.
- .Coloque los artículos más pesados en las gavetas de abajo.



INFORMACIÓN SOBRE EL MONTAJE:

- Durante el proceso de montaje, ya utilice pernos o tornillos, compruebe cada uno de ellos colocando el perno/tornillo en el diagrama del artículo donde está dibujado el tamaño y el diseño real. Asegúrese de que utiliza el tamaño y la forma adecuada que especifican las instrucciones.
- Para montar esta unidad, puede que se le solicite que coloque la unidad de lado y de cara. Se recomienda encarecidamente que realice el montaje sobre una superficie no abrasiva (Como la envoltura de embalaje de espuma) para evitar dañar el acabado.

INFORMACIÓN SOBRE EL USO:

Mantenga a los niños y otras personas a salvo siguiendo estas sencillas reglas:

- **No permita** que ningún niño juegue sobre muebles.
- **No permita** que nadie trepe sobre un mueble.
- **No permita** que nadie se cuelgue de un mueble.
- Vigile siempre la actividad de su hijo cuando se encuentre en su cuarto.

NOTAS SOBRE SU CUIDADO Y MANTENIMIENTO:

- **No** arañe ni desconche el acabado.
- Inspeccione el producto con regularidad, póngase en contacto con Delta Children's Products para el recambio de partes o para formular preguntas.
- **No** guarde el producto ni ninguna de sus partes a temperaturas ni en condiciones extremas como un ático caluroso o un sótano húmedo y frío. Estos extremos pueden provocar una pérdida de integridad estructural.
- Para preservar el brillo del acabado de alta calidad que recubre su producto, se recomienda que coloque un paño o una almohadilla de fieltro debajo de cualquier objeto que coloque sobre el acabado.
- Límpielo con un trapo húmedo y luego con uno seco para preservar el brillo y la belleza originales de este fino acabado.
- No** utilice productos químicos abrasivos.
- No** pulverice limpiadores directamente sobre el mueble.
- Elévelo ligeramente cuando lo mueva sobre alfombras o moqueta para evitar que se rompan las patas.
- El uso de vaporizadores cerca de muebles puede provocar que la madera se hinche y acabe desconchándose.

PARTS: MAKE SURE THAT ALL PRE-ASSEMBLED PARTS ARE TIGHT
PIEZAS: ASEGÚRESE DE QUE TODAS LAS PIEZAS PRE-ENSAMBLADAS ESTÁN BIEN APRETADAS.

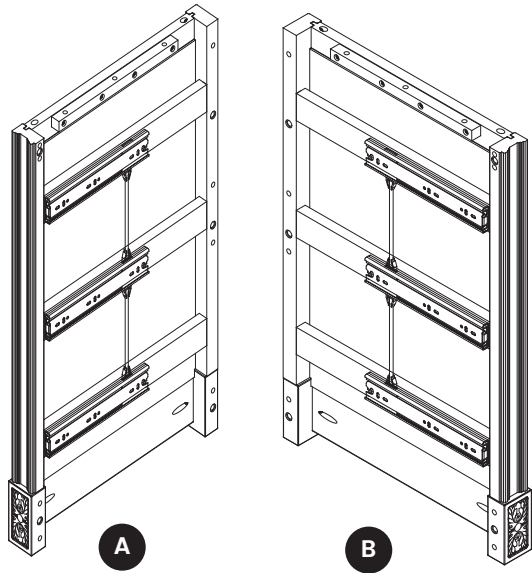

A
 Left Side x1
 Lado izquierdo
 #43686

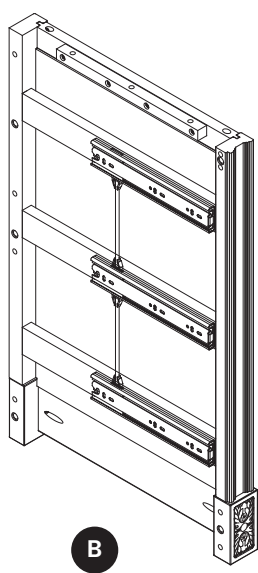

B
 Right Side x1
 Lado derecho
 #43687

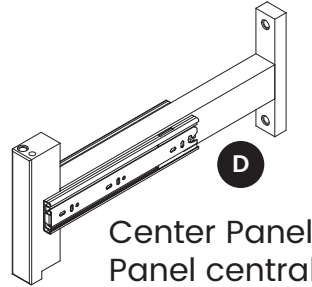

D
 Center Panel
 Panel central
 #43688

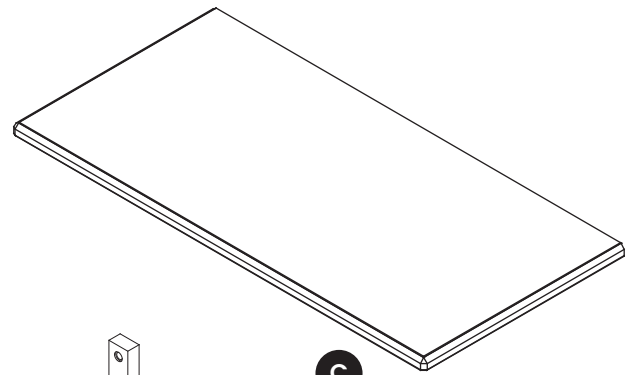

C
 Top Panel
 Panel superior
 #43689



M
 Foot x4
 Pies
 #40819

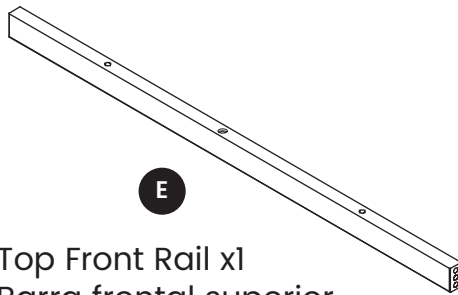

E
 Top Front Rail x1
 Barra frontal superior
 #43690

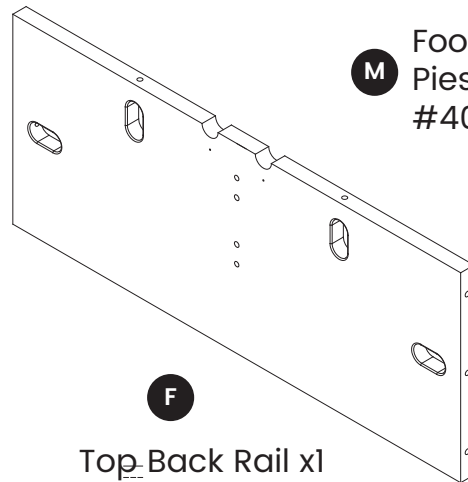

F
 Top Back Rail x1
 Barra trasero
 superior
 #43693

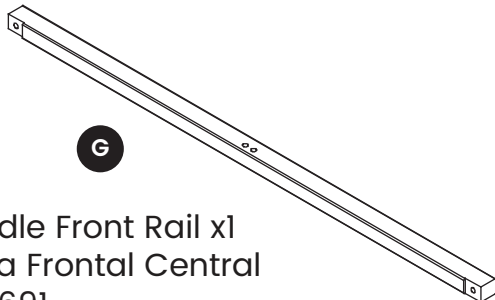

G
 Middle Front Rail x1
 Barra Frontal Central
 #43691



L
 Bottom Front Rail x1
 Barra frontal inferior
 #43692

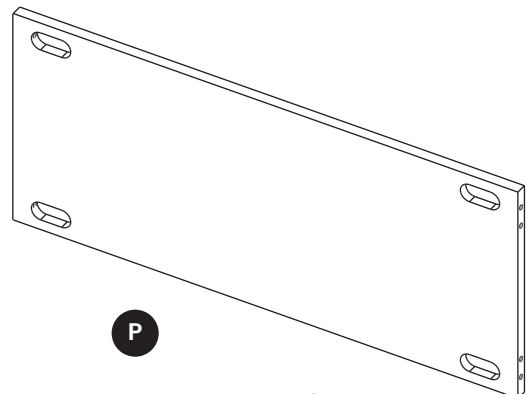

P
 Bottom Back Rail x1
 Barra trasero inferior
 #43694

PARTS: MAKE SURE THAT ALL PRE-ASSEMBLED PARTS ARE TIGHT
PIEZAS: ASEGÚRESE DE QUE TODAS LAS PIEZAS PRE-ENSAMBLADAS ESTÁN BIEN APRETADAS.

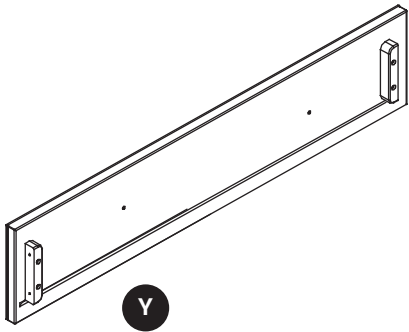

Y
 Drawer Front x2
 Parte frontal de la gaveta
 #43699

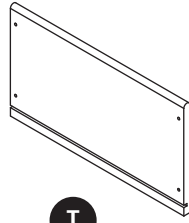

T
 Drawer Side 143 x8
 Barra de la gaveta 143
 #43990

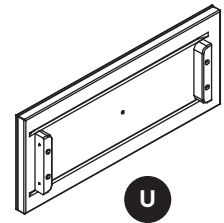

U
 Small Drawer Front x2
 Parte frontal pequeño de la gaveta
 #43695

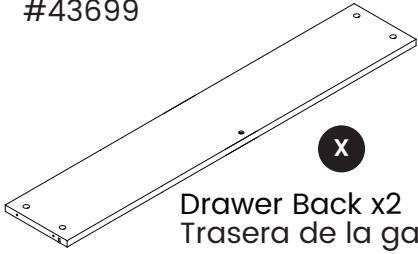

X
 Drawer Back x2
 Trasera de la gaveta
 #43700

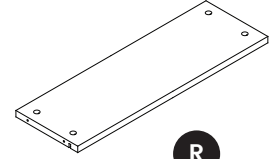

R
 Small Drawer Back x2
 Trasera pequeña de la gaveta
 #43696

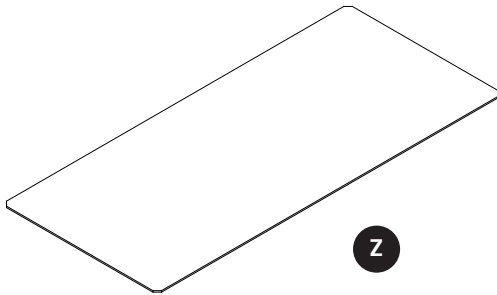

Z
 Drawer Bottom x2
 Fondo de la gaveta
 #43701



W
 Drawer Support x2
 Soporte de la Gaveta
 #43702

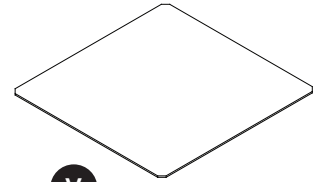

V
 Small Drawer Bottom x2
 Fondo pequeño de la gaveta
 #43697

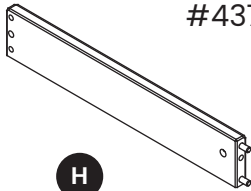

H
 Changing Top Left Side x1
 Lado izquierdo del cambiador
 #40822

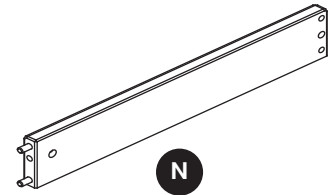

N
 Changing Top Right side x1
 Lado derecho del cambiador
 #40823

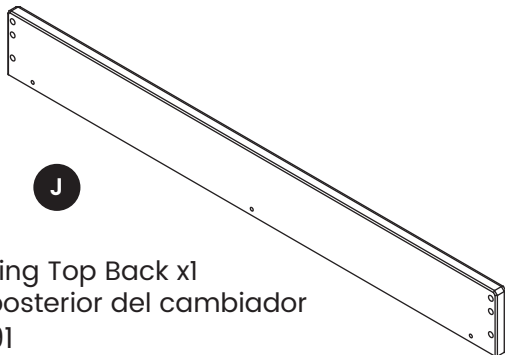

J
 Changing Top Back x1
 Parte posterior del cambiador
 #43991

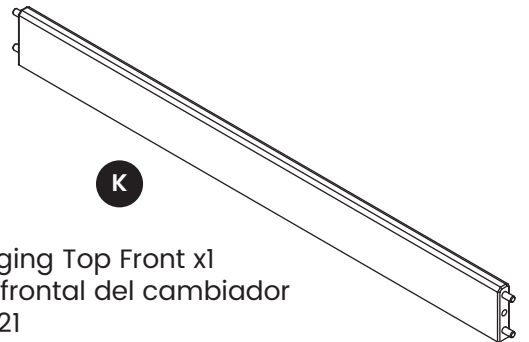

K
 Changing Top Front x1
 Parte frontal del cambiador
 #40821

PARTS: HARDWARE KITS PART#43703
PIEZAS: EL KIT DE HERRAMIENTAS - PIEZA #43703



BB 50mm Bolt x17
 Perno 50mm
 5467

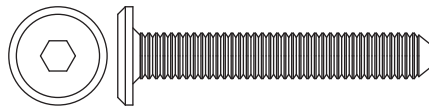

HH 40mm Bolt x5
 Perno 40mm
 5465

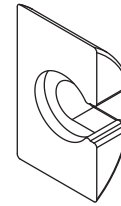

GG Crescent Washer x12
 Arandela de media luna
 5202

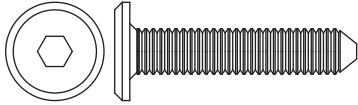

DD 30mm Bolt x4
 Perno 30mm
 5463



CC 10x15mm Barrel Nut x2
 Tuerca cilíndrica 10x15mm
 5478



FF Dowel x22
 Pasado
 5486



LL 20mm Screw x16
 Tornillo 20mm
 6069

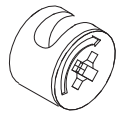

AA Cam lock x2
 Cerradura de Leva
 6127

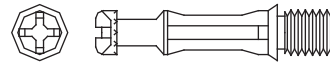

EE Cam bolt x2
 Perno De Leva
 6128



WW 12mm Screw x24
 Tornillo 12mm
 5736

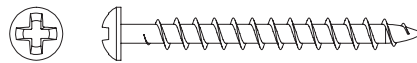

JJ 40mm Screw x21
 Tornillo 40mm
 5209

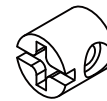

KK Plastic Barrel Nut x18
 Tuercacilíndrica plástica
 5497

PP Handle / Manija x6
 #40800

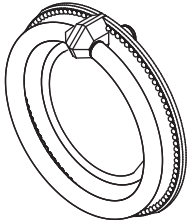

PP2 Knob Screw
 Tornillo para Perilla

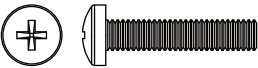

PP1 Handle
 Manija

Anti-tip Device / Dispositivo anti-volcaduras
 4779

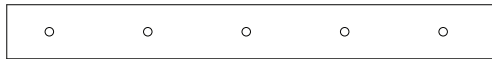

ZZ Wall Strap x1
 Abrazadera

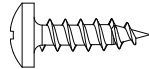

TT Washer x2
 Arandela

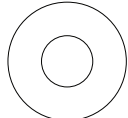

YY Short Screw x1
 Tornillo corto

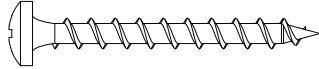

XX Long Screw x1
 Tornillo Largo



M4 Ballend Screwdriver
 destornillador M4 con cabeza de bola
 5818

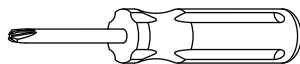

Phillips Screwdriver – Not included
 Destornillador Phillips – no incluido

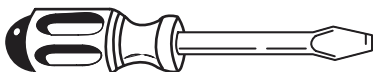

Flat Screwdriver – Not included
 destornillador de cabeza plana – no incluido

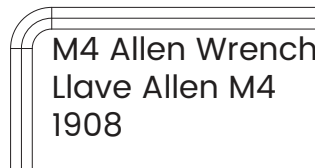

M4 Allen Wrench
 Llave Allen M4
 1908

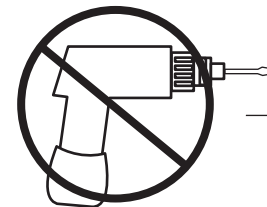

No drills necessary.
 Do not use power screwdriver.

No hace falta taladrar.
 No utilice destornilladores eléctricos

Hardware System - Review Before Assembly
Revise Antes De Armar- Elementos De Fijacion Y Ensamble

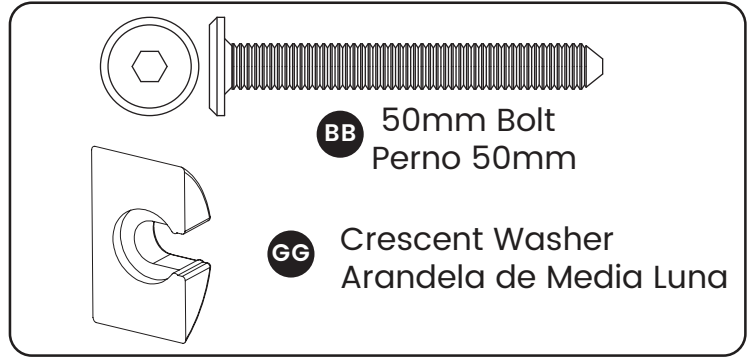
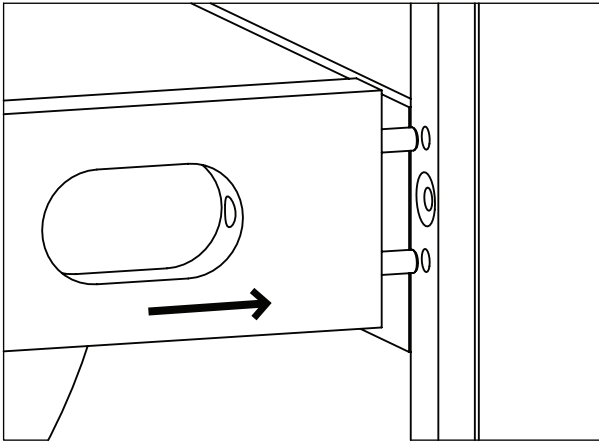

1. Insert the Dowels in the Rail into the holes in the Post.

1. Inserte los pasadores del Riel en los agujeros del Poste.

2. Slide the Crescent Washer into the slot, over the hole.

2. Deslice la arandela de media luna en la ranura, sobre el orificio.

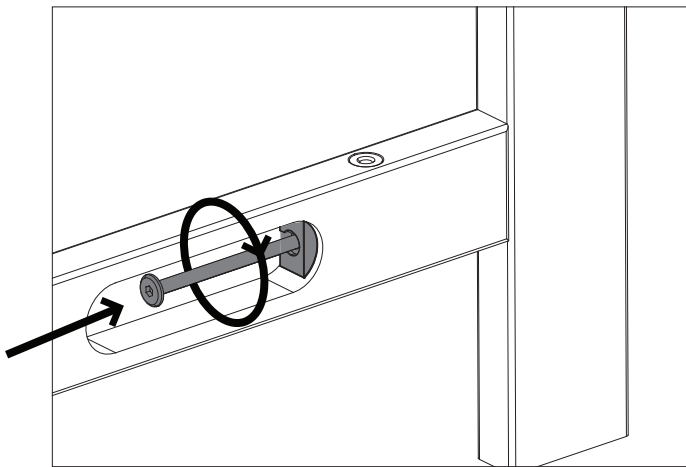
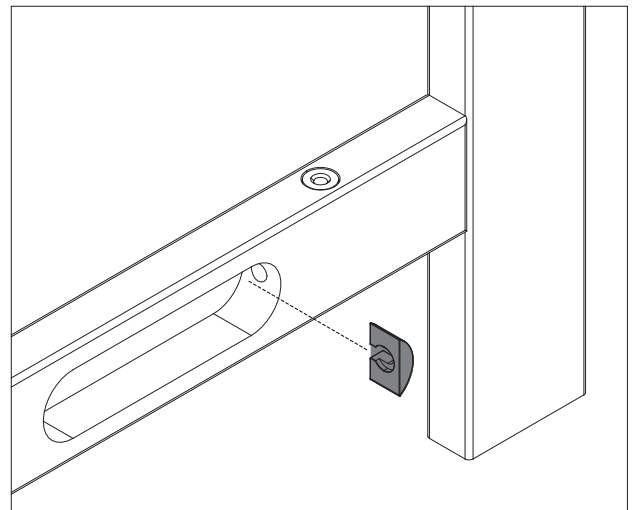

3. Install the bolt through the crescent washer and tighten as shown.

3. Instale el perno a través de la arandela de media luna y apriete como se muestra.

Install (1) bolt and (1) crescent washer at a time. Tighten until it looks like the picture.

Instale (1) perno y (1) Arandela de media luna al mismo tiempo. Apriételos hasta que quede como en la ilustración.

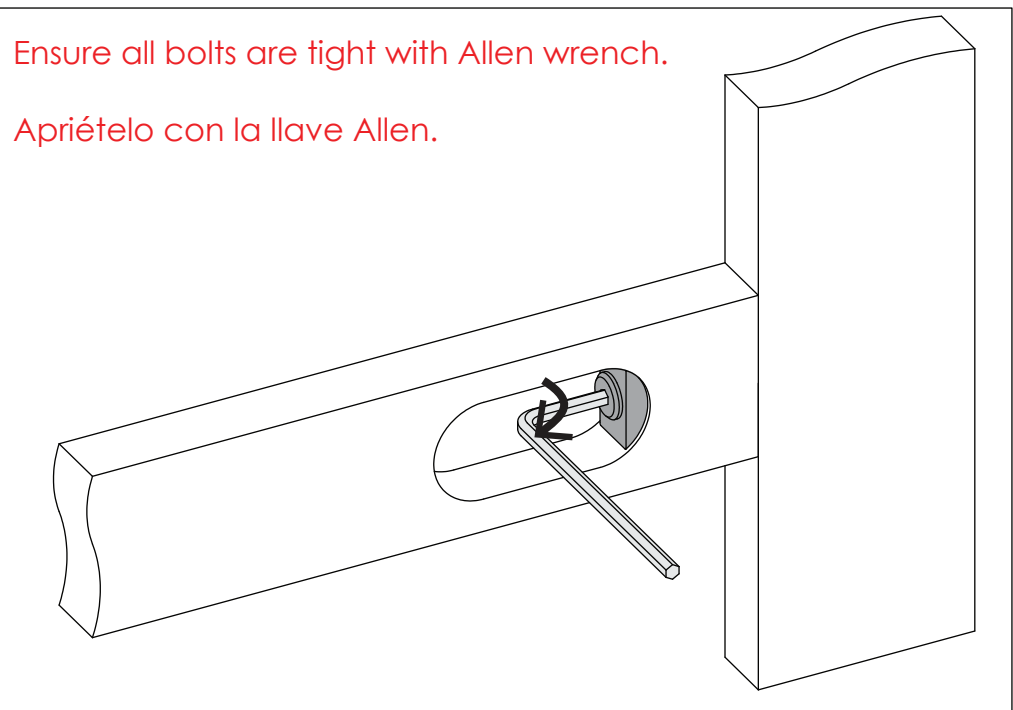
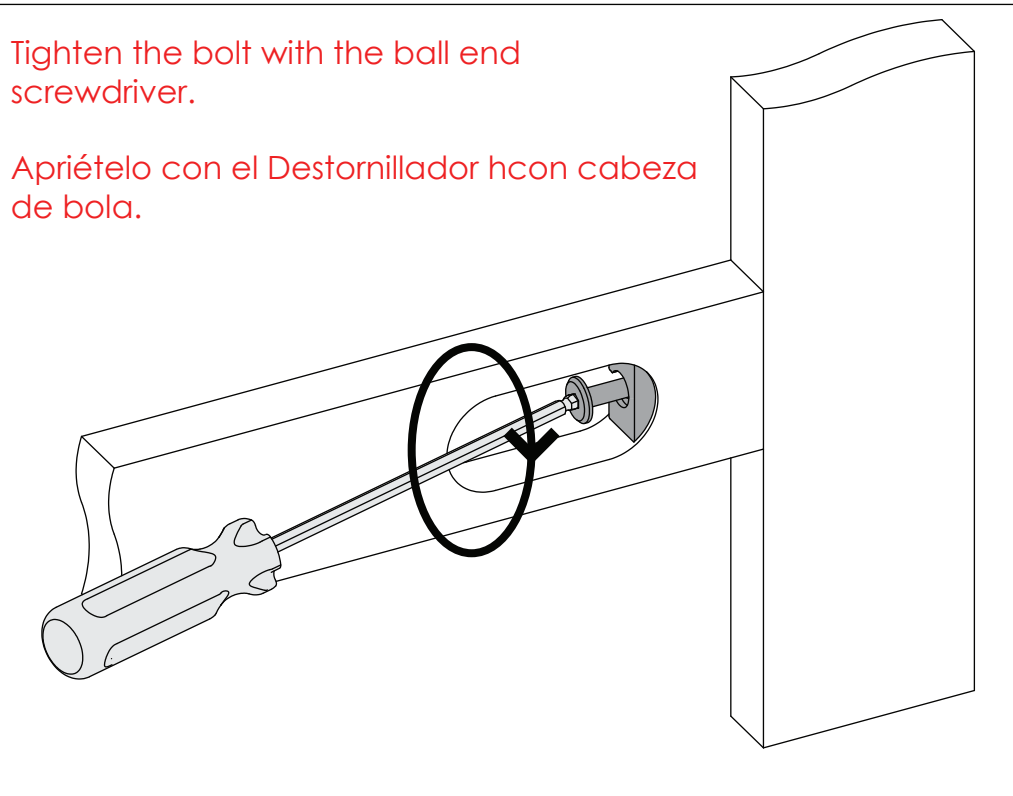

STEP 1
PASO 1

Parts and tools required to complete step
Piezas y herramientas necesarias para completar este paso



BB 50mm Bolt x1
Perno 50mm

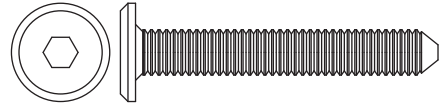

HH 40mm Bolt x1
Perno 40mm



FF Dowel x2
Pasador



M4 Allen Wrench
Llave Allen M4

Attach the Middle Front Rail (Part G) and Top Front Rail (Part E) to Center panel (Part D) using (1) 40mm bolt (Part HH), (1) 50mm bolt (Part BB) and (2) Dowels (Part FF). Tighten bolts with M4 Allen wrench provided.

Fije el Barra Frontal Central (Pieza G) y Barra Frontal Superior (Pieza E) al Panel Central (Pieza D) utilizando (1) Perno 40mm (Pieza HH), (1) Perno 50mm (Pieza BB) y (2) Pasadores (Pieza FF). Apriete todos los pernos utilizando la llave Allen M4 incluida.

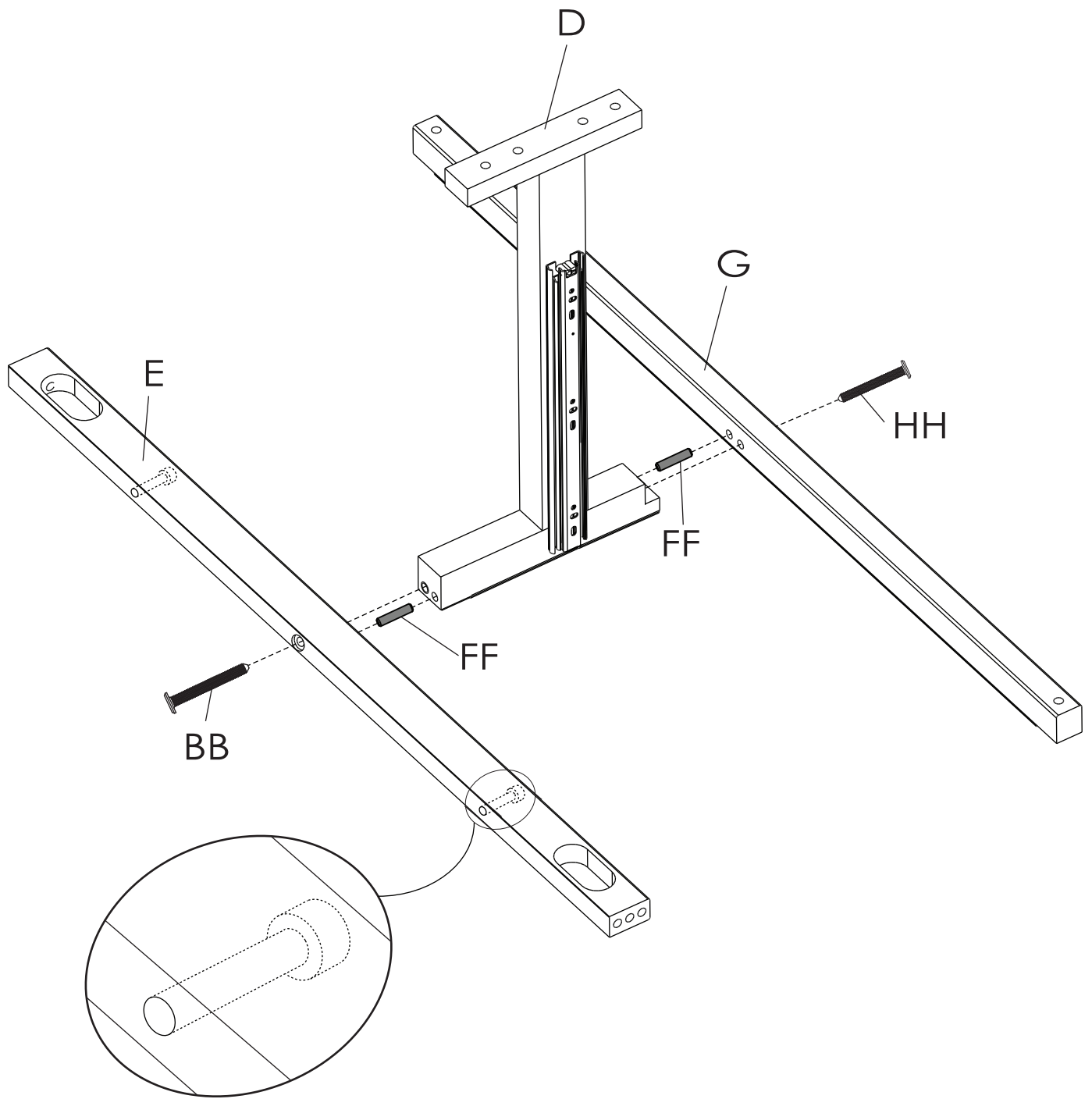

STEP 2
PASO 2

Parts and tools required to complete step
Piezas y herramientas necesarias para completar este paso



BB 50mm Bolt x3
Perno 50mm



GG Crescent Washer x3
Arandela de media luna



FF Dowel x4
Pasador



M4 Allen Wrench
Llave Allen M4



M4 Ballend Screwdriver
destornillador M4 con cabeza de bola

Attach the Top Back Rail (Part F) and Bottom Back Rail (Part P) to the Left Side (Part A) using (4) Dowels (Part FF), (3) 50mm Bolts (Part BB) and (3) Crescent Washers (Part GG). Tighten the Bolts with the M4 Ballend Screwdriver and M4 Allen wrench, following the instructions on pages 14 and 15.

Fije el Barra Posterior Superior (Pieza F) y la Barra trasero inferior (Parte P) al Lado Izquierdo (Parte A) utilizando (4) Pasadores (Pieza FF), (3) Pernos 50 mm (Pieza BB) y (3) Arandelas de Media Luna (Pieza GG) utilizando el destornillador M4 con cabeza de bola y la llave Allen M4 siguiendo las instrucciones de las páginas 14 y 15.

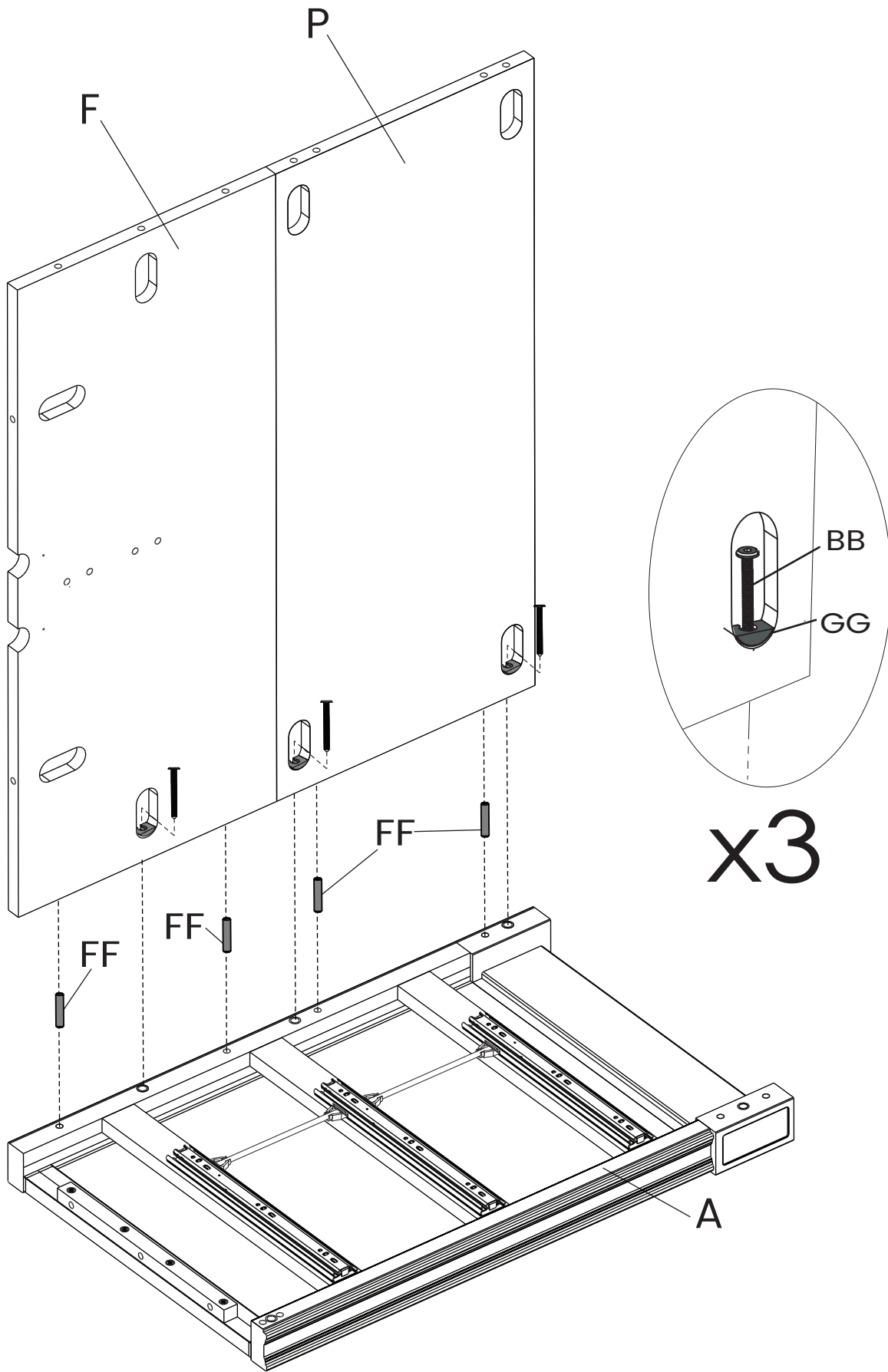

STEP 3 PASO 3

Parts and tools required to complete step
Piezas y herramientas necesarias para completar este paso

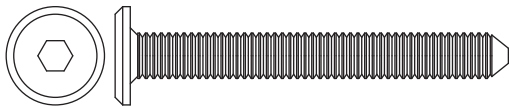

BB 50mm Bolt x2
Perno 50mm

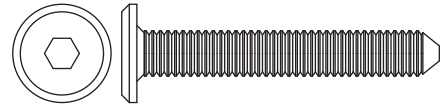

HH 40mm Bolt x3
Perno 40mm



FF Dowel x6
Pasador



GG Crescent Washer x2
Arandela de media luna



M4 Allen Wrench
Llave Allen M4



M4 Ballend Screwdriver
destornillador M4 con cabeza de bola

Attach the assembly from Step 1 and the Bottom Front Rail (Part L) to the assembly from Step 2 using (6) Dowels (Part FF), (3) 40mm Bolts (Part HH), (2) 50mm Bolts (Part BB) and (2) Crescent Washers (Part GG). Tighten the Bolts with the M4 Ballend Screwdriver and M4 Allen wrench, following the instructions on pages 14 and 15.

Fije el ensamblaje del Paso 1 y (1) Barra frontal inferior (Pieza L) al el ensamblaje del Paso 2 utilizando (6) Pasadores (Pieza FF), (3) Pernos 40mm (Pieza HH), (2) Pernos 50 mm (Pieza BB) y (2) Arandelas de Media Luna (Pieza GG) utilizando el destornillador M4 con cabeza de bola y la llave Allen M4 siguiendo las instrucciones de las páginas 14 y 15.

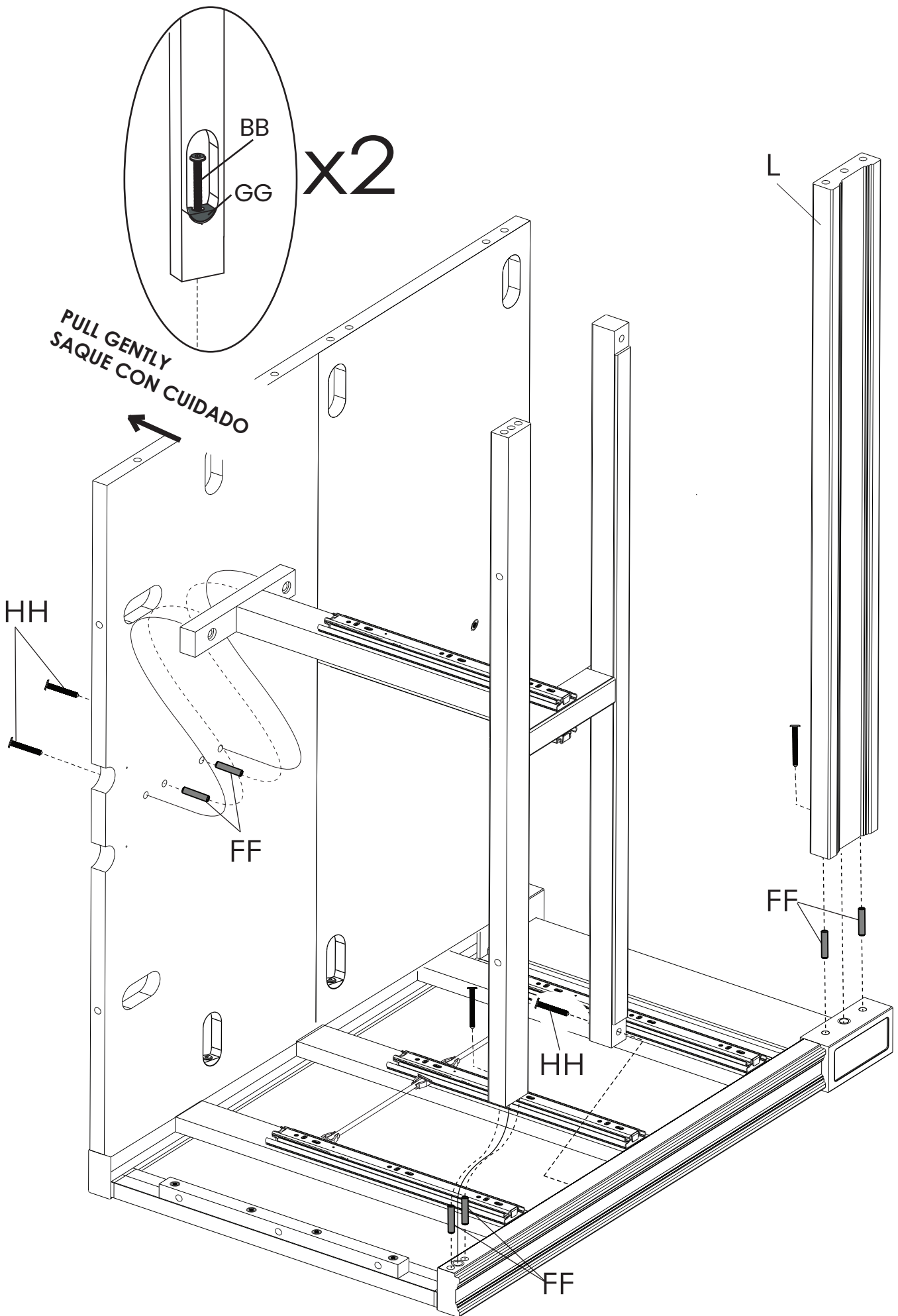

STEP 4
PASO 4

Parts and tools required to complete step
Piezas y herramientas necesarias para completar este paso

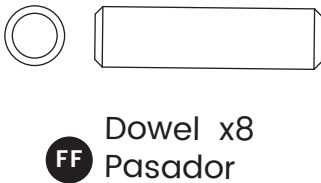
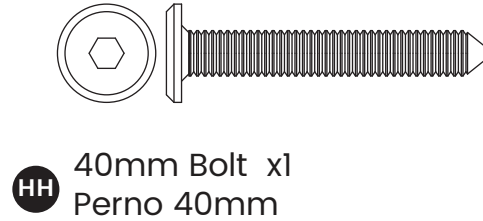

Attach the Right Side (Part B) using (8) Dowels (Part FF), (1) 40mm Bolt (Part HH), (5) 50mm Bolts (Part BB) and (5) Crescent Washers (Part GG). Tighten the Bolts with the M4 Ballend Screwdriver and M4 Allen wrench, following the instructions on pages 14 and 15.

Fije el Lado derecho (Pieza B) utilizando (8) Pasadores (Pieza FF), (1) Perno 40mm (Pieza HH), (5) Pernos 50 mm (Pieza BB) y (5) Arandelas de Media Luna (Pieza GG) utilizando el destornillador M4 con cabeza de bola y la llave Allen M4 siguiendo las instrucciones de las páginas 14 y 15.

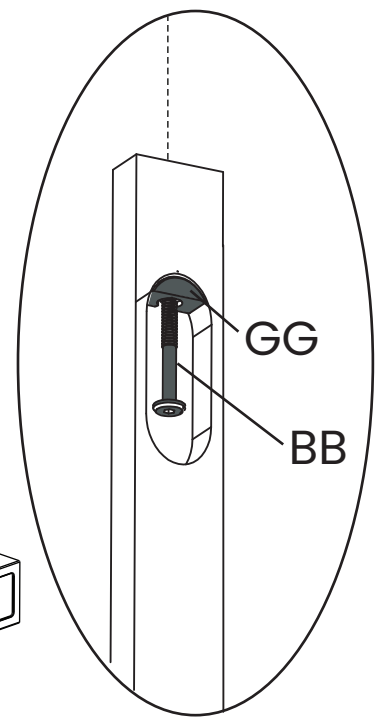
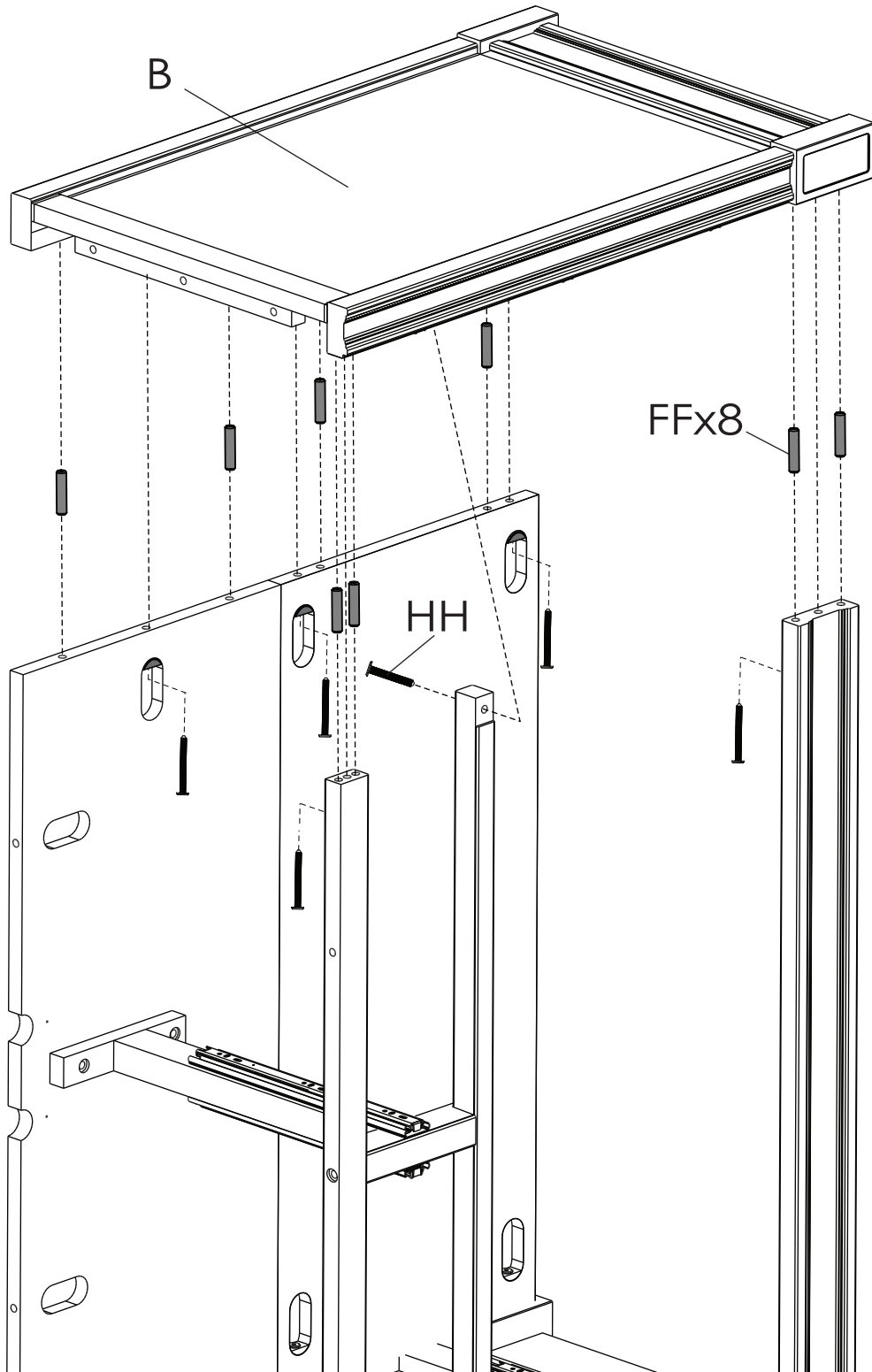

x5

STEP 5
PASO 5

Parts and tools required to complete step

Piezas y herramientas necesarias para completar este paso



M Foot x4
Pies

Attach (1) Foot (Part M) to each
Foot Bracket by hand.

Una (1) Pata (Pieza M) a cada Soporte de
la Pata, atornillando a mano.

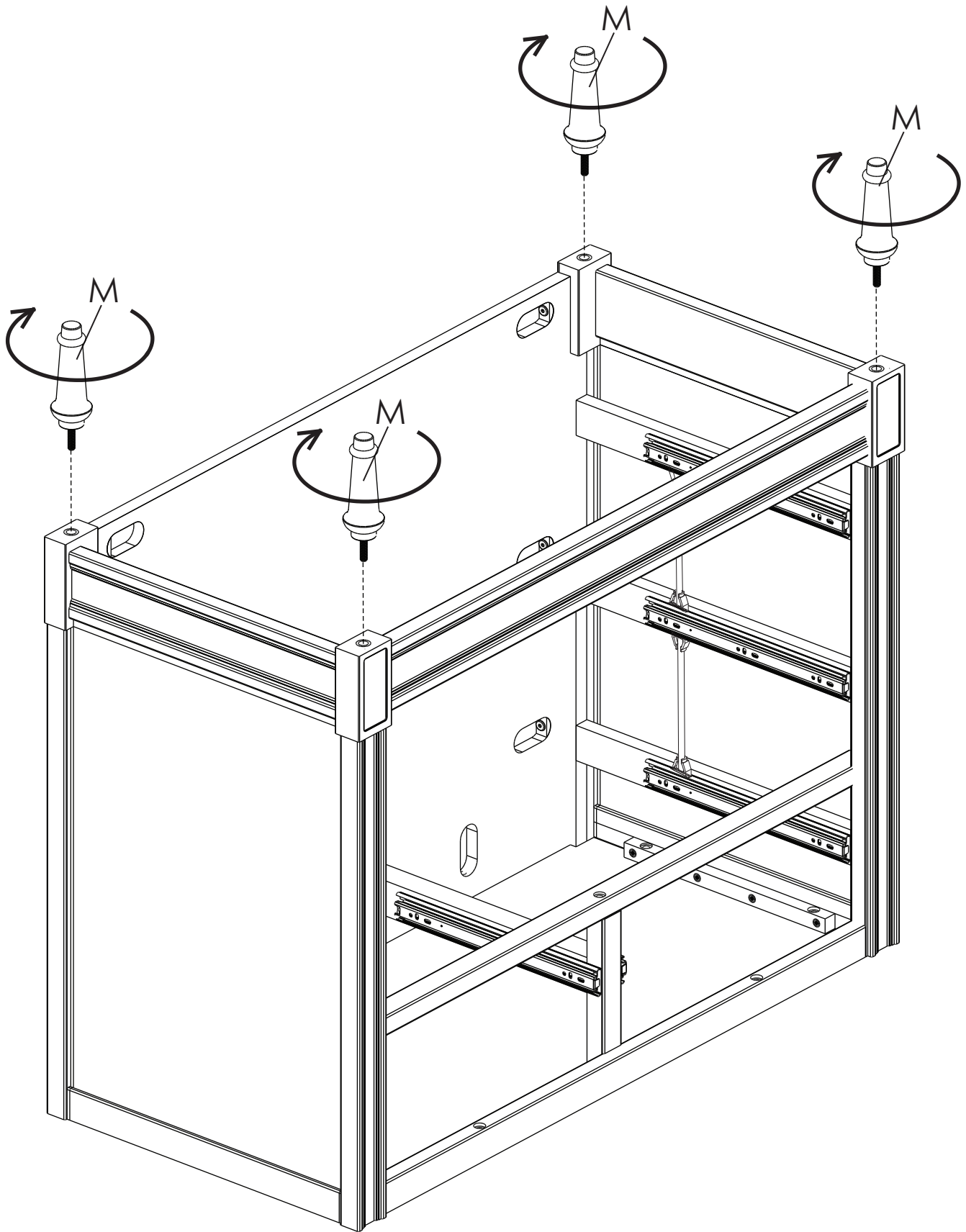

STEP 6
PASO 6

Parts and tools required to complete step
Piezas y herramientas necesarias para completar este paso



BB 50mm Bolt x4
Perno 50mm



GG Crescent Washer x2
Arandela de media luna



FF Dowel x2
Pasador



M4 Allen Wrench
Llave Allen M4



M4 Ballend Screwdriver
destornillador M4 con cabeza de bola

Insert (2) Dowels (Part FF) into the top of Both Sides.
Align the Top (Part C) with the Dowels.
Attach the Top Panel using (4) 50mm Bolts (Part BB) and (2) Crescent Washer (Part GG) . Tighten the Bolts with the M4 Allen wrench.

Instale (2) Pasadores (Pieza FF) encima deambos lados
Alineeel Panel superior (Pieza C) con los pasadores.
Fije el Panel superior utilizando (4) pernos de 50 mm (Pieza BB) y (2) Arandela de Media Luna (Pieza GG) utilizando el destornillador la Llave Allen M4

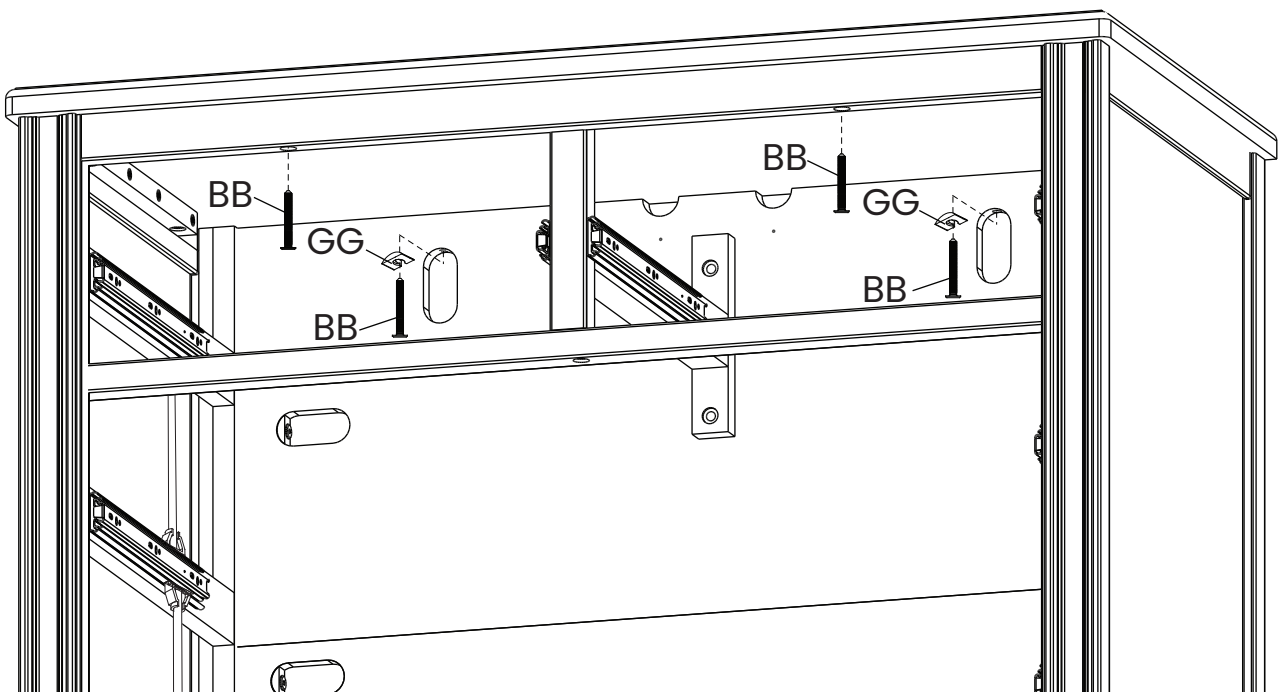
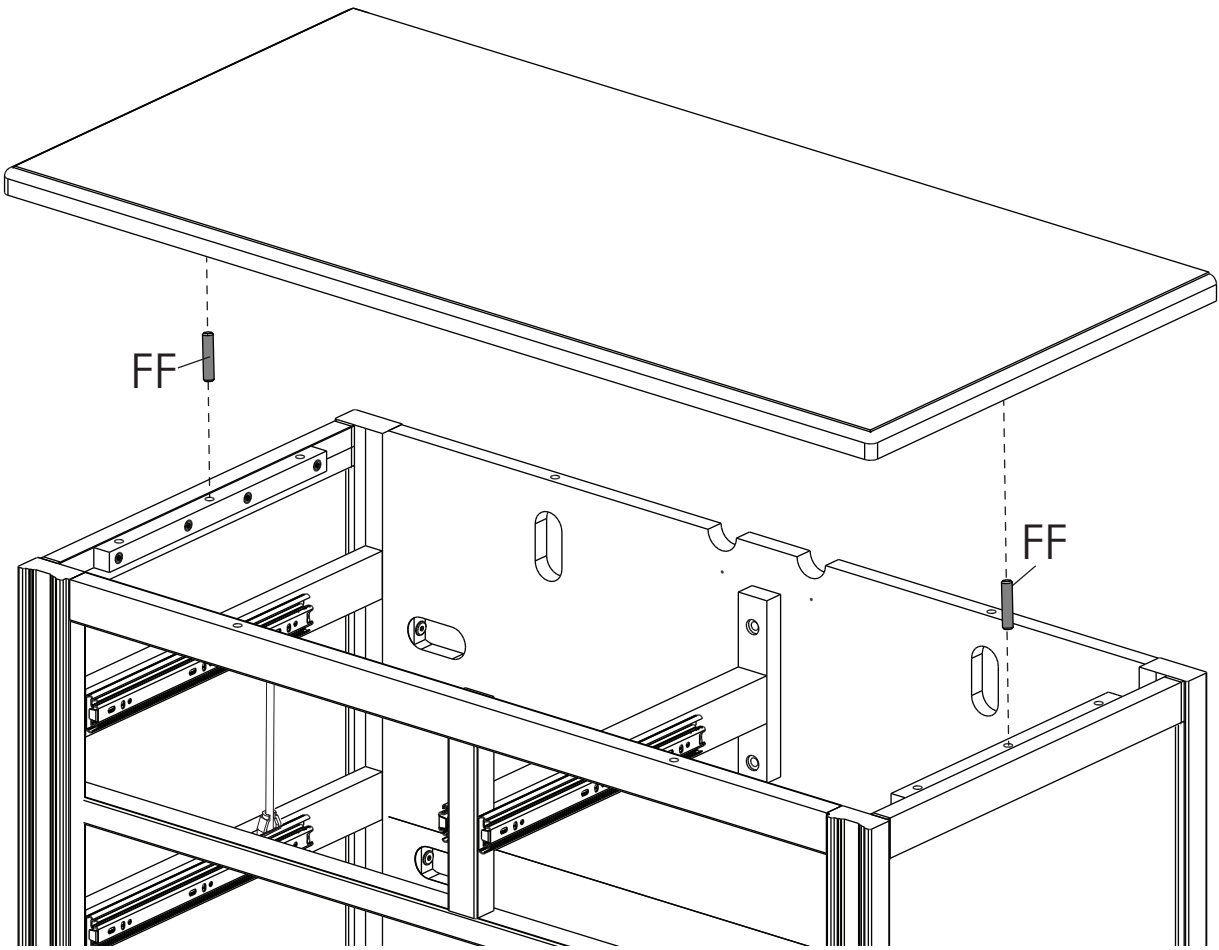

STEP 7
PASO 7

Parts and tools required to complete step

Piezas y herramientas necesarias para completar este paso

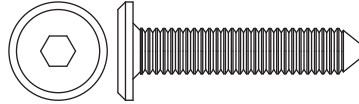
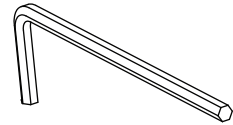
**DD** 30mm Bolt x4
Perno 30mmM4 Ballend Screwdriver
destornillador M4 con cabeza de bolaM4 Allen Wrench
Llave Allen M4

Attach the Top Panel (Part C) using (4) 30mm Bolts (Part DD). Tighten the Bolts with the M4 Ballend Screwdriver and M4 Allen wrench.

Fije el Panel Superior (Pieza C) utilizando (4) Pernos 30mm (Pieza DD) utilizando el destornillador M4 con cabeza de bola y la llave Allen M4.

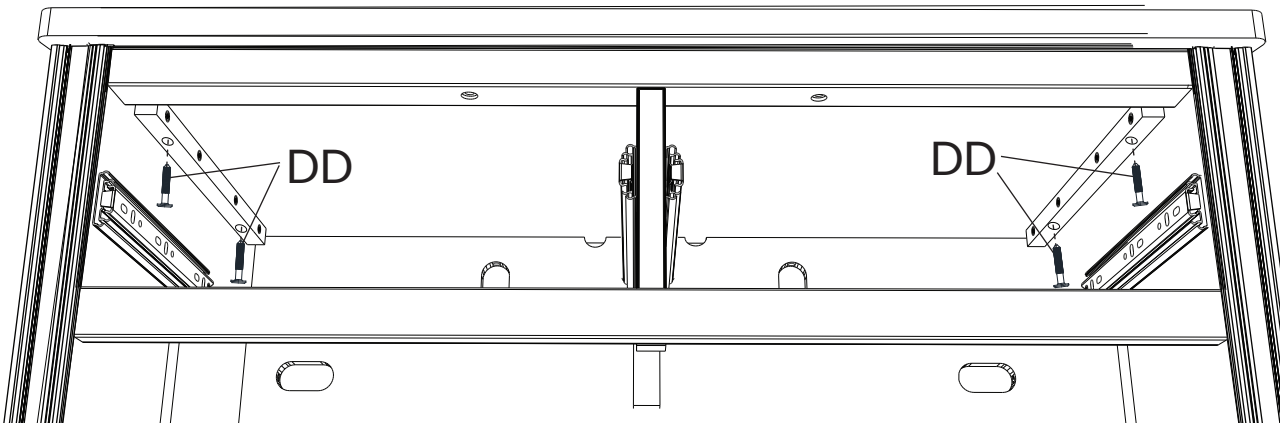

STEP 8
PASO 8

Parts and tools required to complete step
Piezas y herramientas necesarias para completar este paso

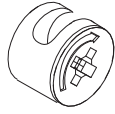

AA Cam lock x2
Cerradura de Leva

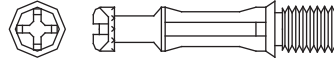

EE Cam bolt x2
Perno De Leva

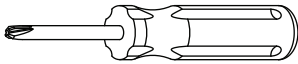

Phillips Screwdriver – Not included
Destornillidor Phillips – no incluido

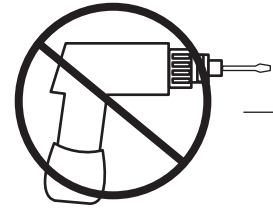

No drills necessary.
Do not use power screwdriver.

No hace falta taladrar.
No utilice destornilladores eléctricos

1. Insert Cam Bolt (Part EE) into Changing Top Right Side (Part N).
2. Insert (1) cam lock (part AA) into the holes on the side of the Changing Top Front (Part K).
3. Attach Changing Top Right Side (Part N) to the Changing Top Front (Part K). Insert and turn the cam lock clockwise to tighten using a phillips screwdriver.
4. Attach Changing Top Left Side (Part H) in the same manner

1. Inserte (1) perno de leva (Pieza EE) en la lado derecho del cambiador (pieza N).
2. Inserte (1) cerraduras (pieza AA) en los orificios en el lado del parte frontal del cambiador (pieza K).
3. Fijar el lado derecho del cambiador (pieza N) con la parte frontal del cambiador (pieza K). Inserte y gire la leva de la derecha para apretar con un destornillador.
4. Fijar el lado izquierdo del cambiador (pieza H) de la misma manera.

How to use the cam lock system
cómo utilizar la leva de bloqueo

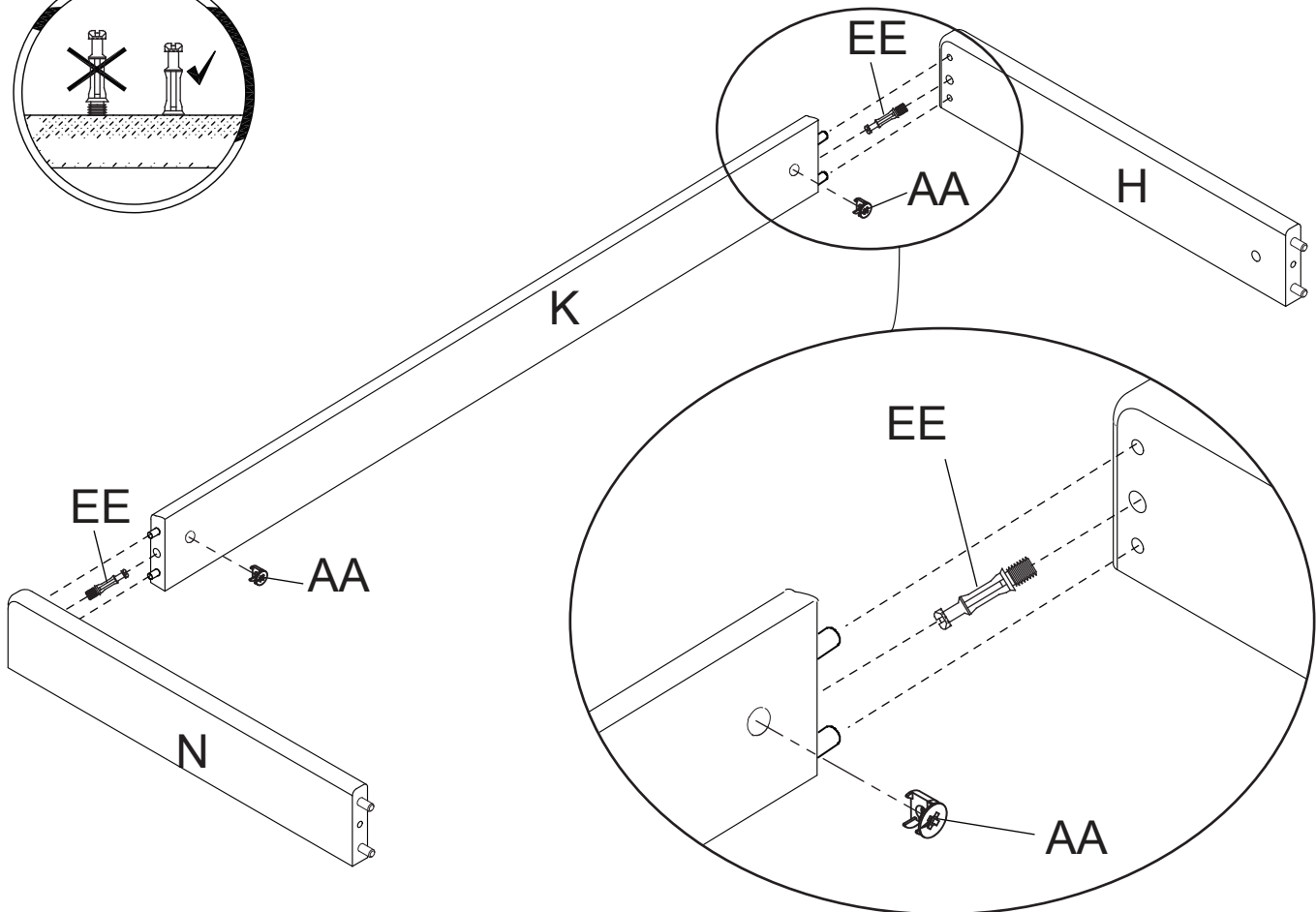
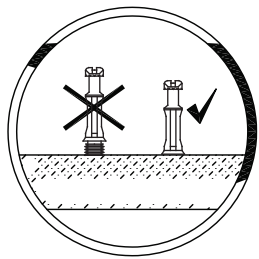
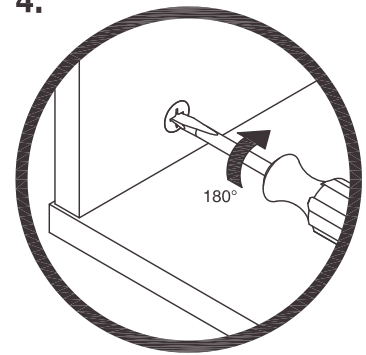
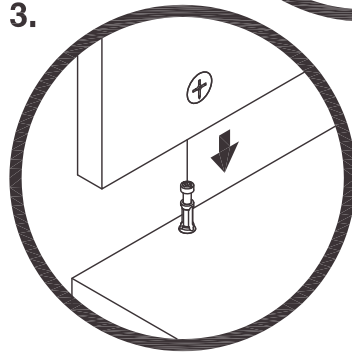
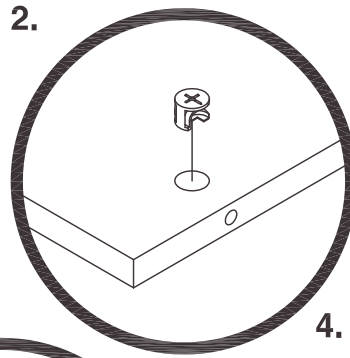
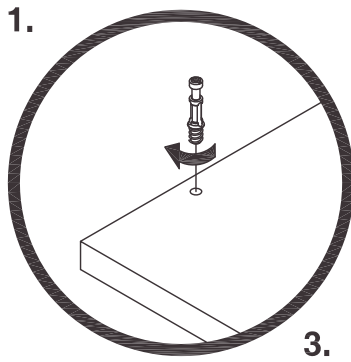

STEP 9 PASO 9

Parts and tools required to complete step

Piezas y herramientas necesarias para completar este paso

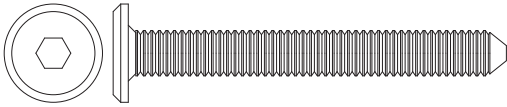

BB 50mm Bolt x2
Perno 50mm

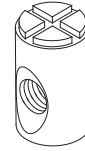

CC 10x15mm Barrel Nut x 2
Tuerca cilíndrica 10x15mm

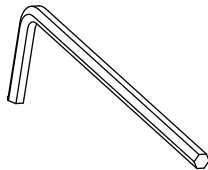

M4 Allen Wrench
Llave Allen M4

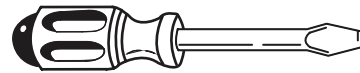

Flat Screwdriver – Not included
destornillador de cabeza plana –
no incluido

Attach Changing Top Back (Part J) to the Right and Left Sides using (2) 50mm Bolts (Part BB) and (2) Barrel Nuts (Part CC). Tighten with the M4 Allen Wrench. Use the Flat Head Screwdriver to hold the Barrel Nut in the proper alignment.

Fijar la parte posterior del cambiador (Pieza J) a los lados derecho e izquierdo utilizando (2) pernos de 50 mm (Pieza BB) y (2) Tuerca cilíndrica (Pieza CC) . Apriete todos los pernos utilizando la Llave Allen M4. Utilice el destornillador de cabeza plana para sostener la tuerca de barril en la alineación adecuada.

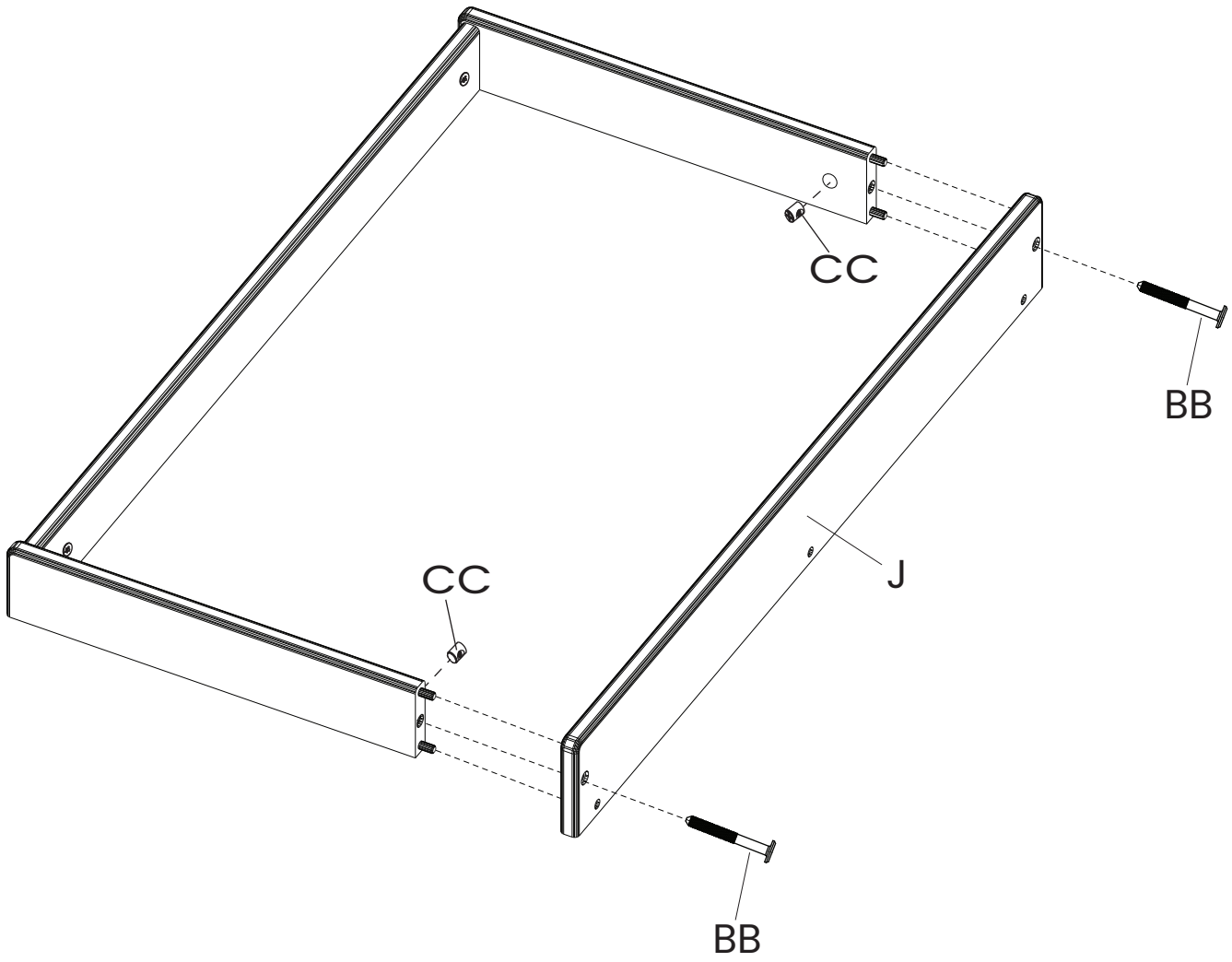

STEP 10
PASO 10

Parts and tools required to complete step

Piezas y herramientas necesarias para completar este paso

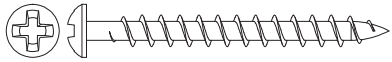

JJ 40mm Screw x3
Tornillo 40mm

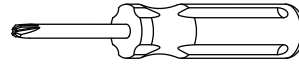

Phillips Screwdriver – Not included
Destornillador Phillips – no incluido

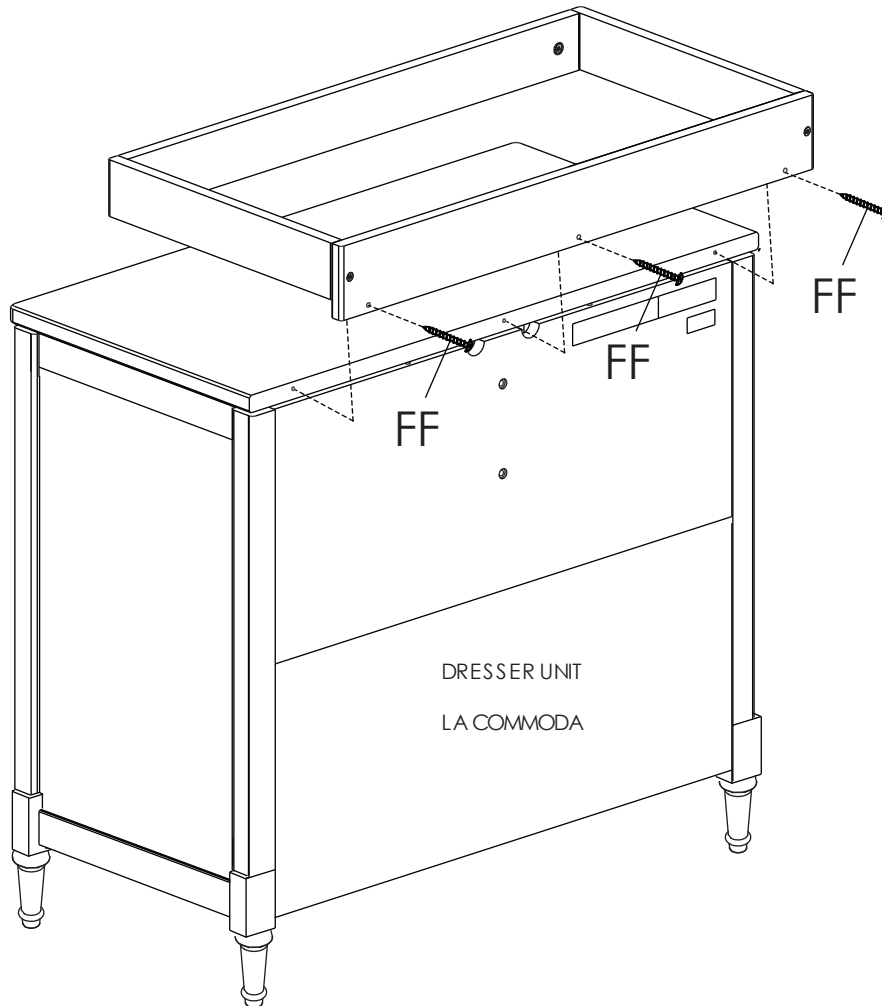

1. Set the Assembled Changing Top on the top of the Dresser as shown.
2. Insert (3) 40mm screws (Part JJ) through the back of the Changing Top, into the pre drilled holes the dresser.
3. Tighten with a Phillips Screwdriver.

1. Poner el equipó de ensamblaje encima del cambiador.
2. Inserta (3) tornillos 40 mm (pieza JJ) en la parte de atrás en los wecos pilót.
3. Apriete con destornillador phillips.

⚠️ WARNING

Fall Hazard Children have suffered serious injuries after falling from changing tables. Falls can happen quickly.

- **STAY** within arm's reach of the child.
- **ALWAYS** secure this unit to the support surface using the screws provided. See instructions.
- Read all instructions before use of the changing top.
- **KEEP THESE INSTRUCTIONS IN A SAFE PLACE FOR FUTURE USE.**
- Inspect the changing top periodically. Do not use the changing top if it is damaged or broken. Contact Delta Children's Products with any questions.
- Tighten all loose screws and bolts before each use.
- The maximum recommended weight of the child is 30lbs for the changing unit.
- Secure the changing unit only to Delta Children's Products item W134440.
- The changing pad used should be 32" x 16" with a maximum thickness of 1".

⚠️ ADVERTENCIA

Peligro de caídas. Hay niños que han sufrido lesiones serias al caer de cambiadores. Las caídas pueden ocurrir en un instante.

- **MANTENERSE** al alcance de la mano del niño.
- Asegurar **SIEMPRE** esta unidad a la superficie de soporte utilizando los tornillos provistos. Ver las instrucciones.
- Lea todas las instrucciones antes de usar el cambiador.
- **COLOQUE ESTAS INSTRUCCIONES EN UN LUGAR SEGURO PARA SU USO FUTURO.**
- Inspeccione este cambiador periódicamente. No use el cambiador si esta dañado o roto. Póngase en contacto con Delta Children's Products para formular preguntas.
- Apriete los tornillos y pernos flojos antes de cada uso.
- El peso máximo recomendado para los niños que usen el cambiador es 30 libras (13,6 kilos).
- Asegure el cambiador sólo al producto Delta Children's Products W134440.
- La almohadilla usada debe ser 32 x 16 pulgadas con un grosor máximo de 1 pulgada.

STEP 11
PASO 11

Tipover Restraint
Protección contra volcamiento

▲ WARNING

Use of tip-over restraints may only reduce, but not eliminate, the risk of tip-over.

Do not attempt to Screw into the wallboard only. You must Screw into a wood wall stud or other wood structure such as securely attached baseboard. If your wall is not wood stud construction, see your local hardware store or home center for a wall anchor system that will hold a pull force of 50 LBS in your wall type. If you are unsure of how to locate the wood stud, or of what type of wall you have, contact a professional contractor.

▲ ADVERTENCIA

El uso de herramientas de contención de vuelcos tan solo puede reducir, pero no eliminar, el riesgo de vuelco.

No intente atornillar a paredes hechas únicamente de paneles. Debe atornillar en un pilar u otra estructura de madera similar, como un zócalo fijado de manera segura. Si su pared no tiene vigas de Madera, visite su ferretería o tienda del ramo más cercana para conseguir un sistema de anclaje que soporte una fuerza de tiraje de hasta 50 LBS (22,7 Kgs) para su tipo de muro. Si no está seguro sobre cómo encontrar la viga de madera o tiene dudas sobre el tipo de muro, contacte a un contratista profesional.

- 1) Choose BOTTOM or TOP attachment.
- 2) Locate the through holes in the back of the dresser.
- 3) Align the hole to be used with the wood wall stud (For Open Bottom Installation, use wood wall stud closest to center)

- 1) Seleccione el aditamento SUPERIOR o INFERIOR.
- 2) Ubique los orificios pasantes en la parte posterior del mueble.
- 3) Alinee el orificio que utilizará con el pilar de la pared (para una instalación con fondo abierto, utilice el pilar de madera más cercano al centro)

4) Make a pencil mark on the wall using the wood rail as a guide, pencil mark must be over wood wall stud. Then move the case away from the wall.

4) Utilizando un lápiz, haga una marca en la pared utilizando el barra de madera como guía; la marca debe estar sobre el pilar de madera. Luego, aleje la carcasa de la pared.

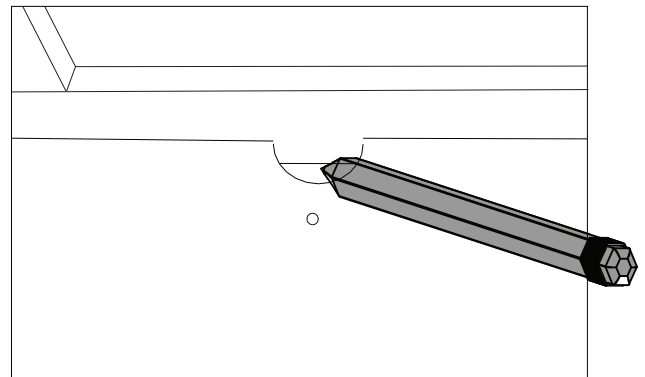

5) Drill $\varnothing 1/8$ " hole at Pencil Mark, in wood wall stud

5) Perfore un orificio de $\varnothing 1/8$ " en la marca del lápiz, sobre el pilar de madera

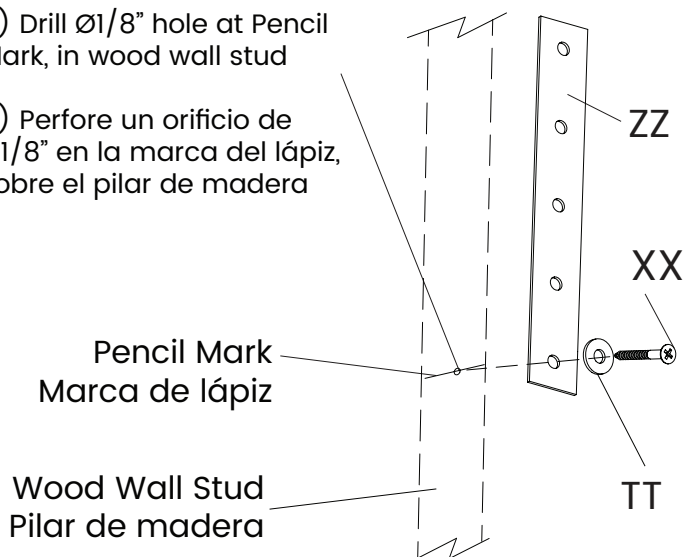

6) Attach the Tip-over restraint strap (ZZ) to the wall using (1) Long Screw (XX) and (1) washer (TT) as shown. The Screw MUST be installed into a wood wall stud (See WARNINGS for additional information).

6) Fije la correa de retención contra volcamiento (ZZ) a la pared utilizando (1) tornillo largo (XX) y (1) arandela (TT), como se indica. El tornillo DEBE instalarse en un pilar de madera (para obtener más información consulte las ADVERTENCIAS).

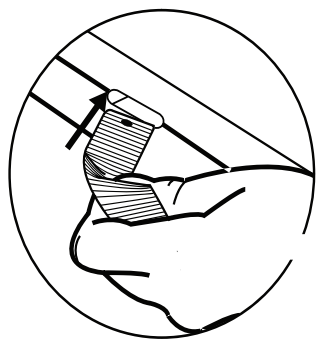

NOTE: Be sure to attach any accessory items to case before completing this step.

7) Feed the Tipover Restraint through the hole as you place the dresser in it's final position.

NOTA: Asegúrese de fijar todos los accesorios a la carcasa antes de completar este paso.

7) Pase el elemento de retención a través del orificio, a medida que posiciona el mueble en su posición final.

8) Pull the Tip-over restraint through the hole and fasten it securely to the case using (1) 15mm Screw (YY) and (1) washer (TT).

8) Pase el elemento de retención a través del orificio y fíjelo con seguridad a la carcasa utilizando (1) tornillo de 15 mm (YY) y (1) arandela (TT).

Attach to Top
Fijar a la parte superior

Attach to Bottom
Fijar al fondo

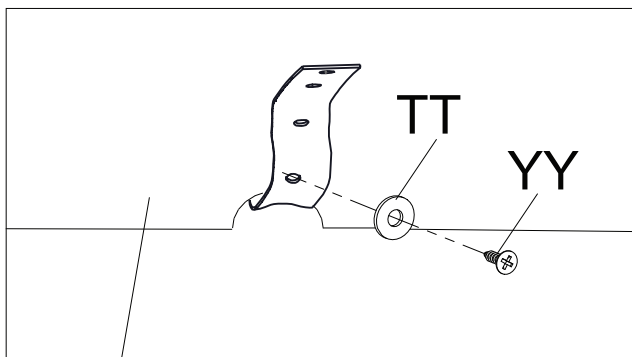
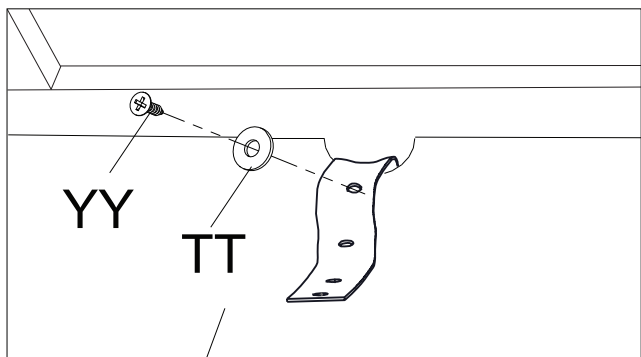

Top Back Rail
Barra Trasero Superior

Bottom Back Rail
Barra Trasero Inferior

9) Pull case AWAY from wall until Restraint is SNUG.
9) Jale la carcasa ALEJÁNDOLA de la pared hasta que la retención esté TENSA.

10) Ensure restraint is not loose.
10) Asegúrese de que la retención no esté suelta.

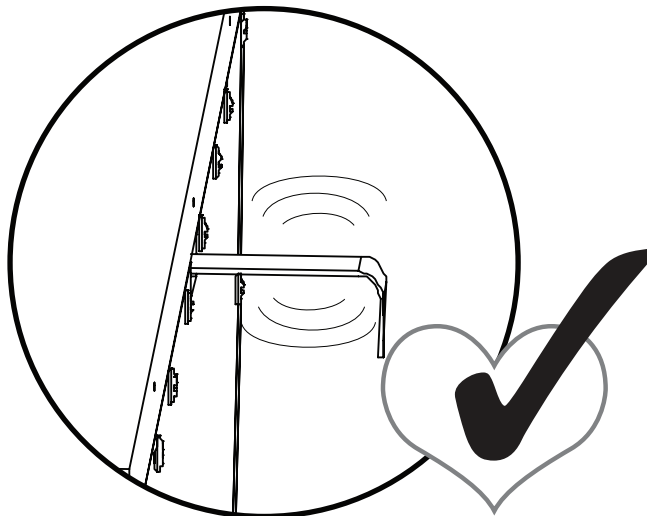
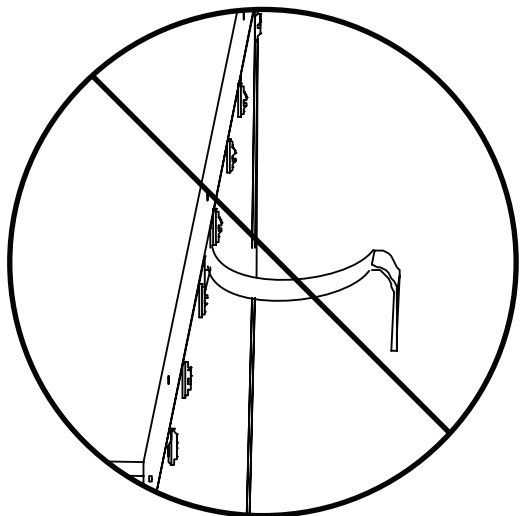

STEP 12
PASO 12

Parts and tools required to complete step
Piezas y herramientas necesarias para completar este paso

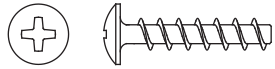

LL 20mm Screw x8
Tornillo 20mm



Phillips Screwdriver – Not included
Destornillador Phillips – no incluido

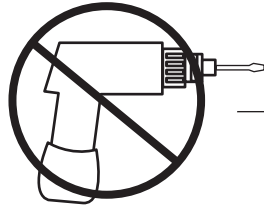

No drills necessary.
Do not use power screwdriver.

No hace falta taladrar.
No utilice destornilladores eléctricos

WARNING Label
Etiqueta de **ADVERTENCIA**

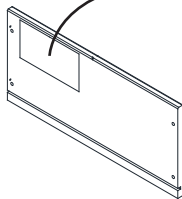

T x1

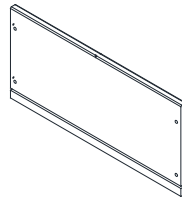

T x3

Slide Small Drawer Bottom (Part V) into the grooves. Attach the Drawer Sides (Part T) to the Small Drawer Fronts (Part U) with (4) 20mm Screws (Part LL). Grooves must align. Tighten With Phillips Screwdriver. Repeat this step until both Top drawers are complete.

Deslice la Fondo pequeño de la gaveta (Pieza V) hacia las ranuras. Fije los Barra de la gaveta (Pieza T) a la Parte frontal pequeño de la gaveta (Pieza U) utilizando (4) tornillos 20mm (Pieza LL). Las ranuras deben alinearse. Apriete utilizando un destornillador Phillips. Repita este paso hasta haber completado las 2 gavetas superior.

WARNING Label
Etiqueta de **ADVERTENCIA**

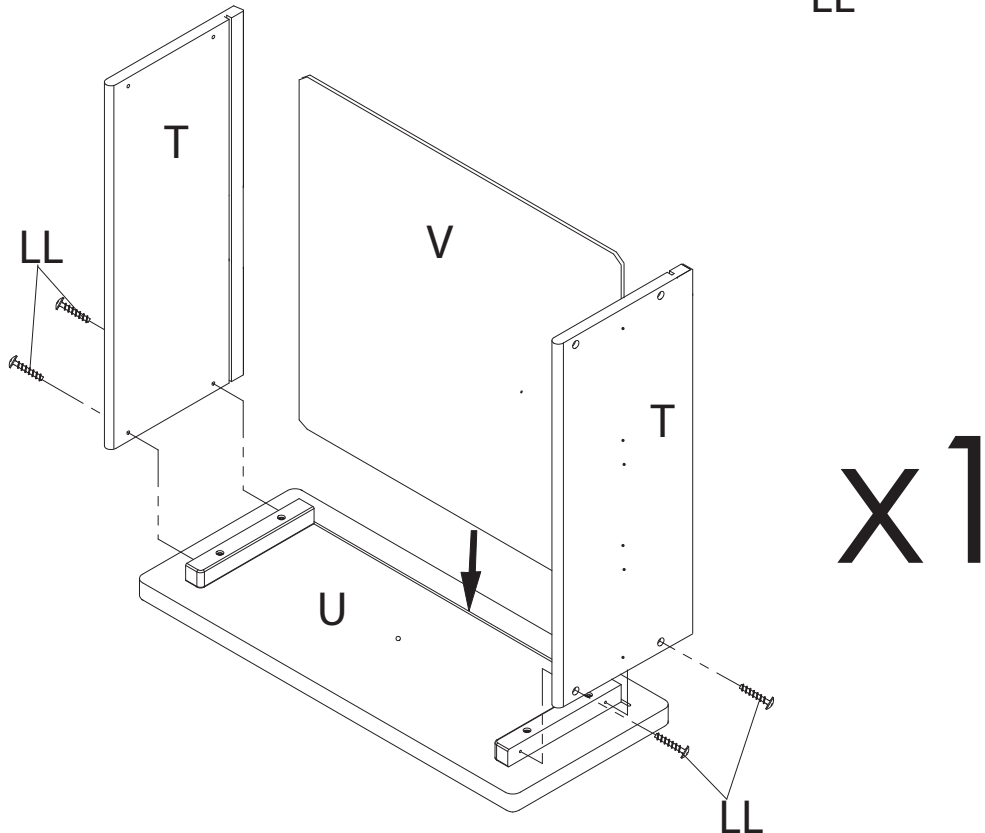
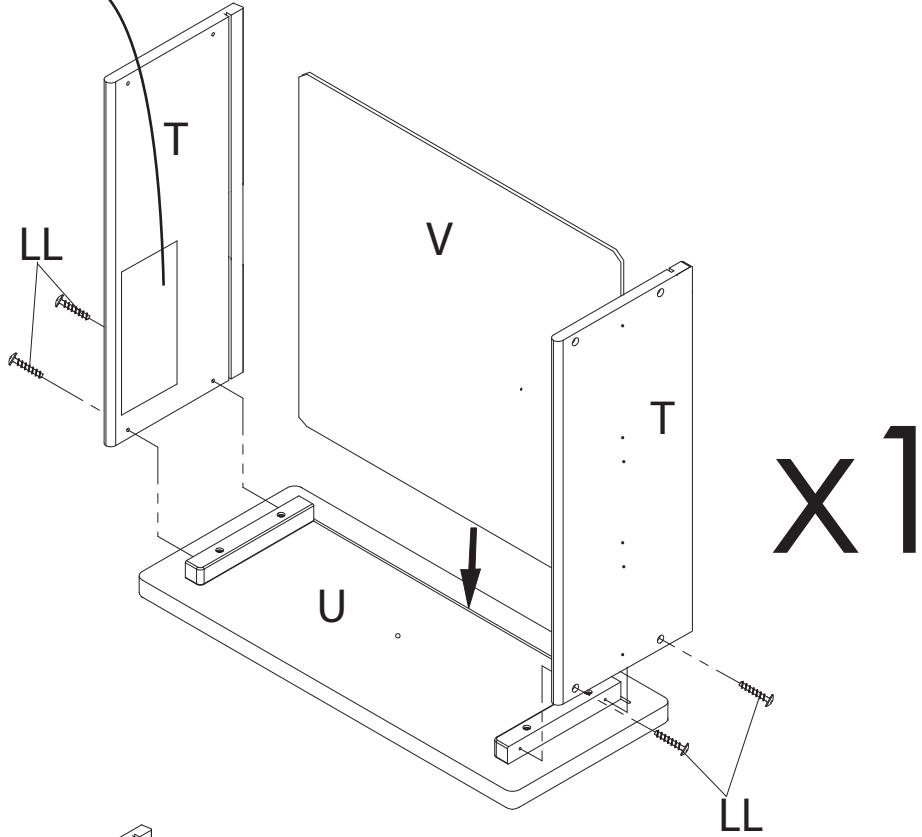

STEP 13

PASO 13

Parts and tools required to complete step
Piezas y herramientas necesarias para completar este paso

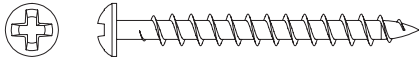

JJ 40mm Screw x8
Tornillo 40mm

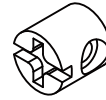

KK Plastic Barrel Nut x8
Tuerca de Barril Plásticas

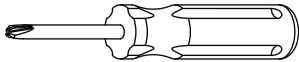

Phillips Screwdriver – Not included
Destornillidor Phillips – no incluido

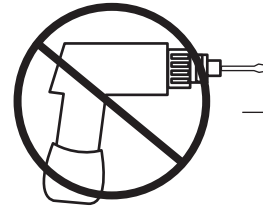

No drills necessary.
Do not use power screwdriver.

No hace falta taladrar.
No utilice destornilladores eléctricos

Install the Small Drawer Back (Part R) using (4) 40mm Screws (Part JJ) and (4) Plastic Barrel Nuts (Part KK). Note: Grooves In Bottom Must Align. Repeat this step until both small drawers are complete.

Instale el Trasera pequeña de la gaveta (Pieza R) utilizando (4) tornillos de 40 mm (Pieza JJ) y (4) tuercas cilíndricas plásticas (Pieza KK). Nota: Las ranuras al inferior deben alinearse. Apriete utilizando un destornillador Phillips. Repita este paso hasta haber completado las 2 pequeña gavetas.

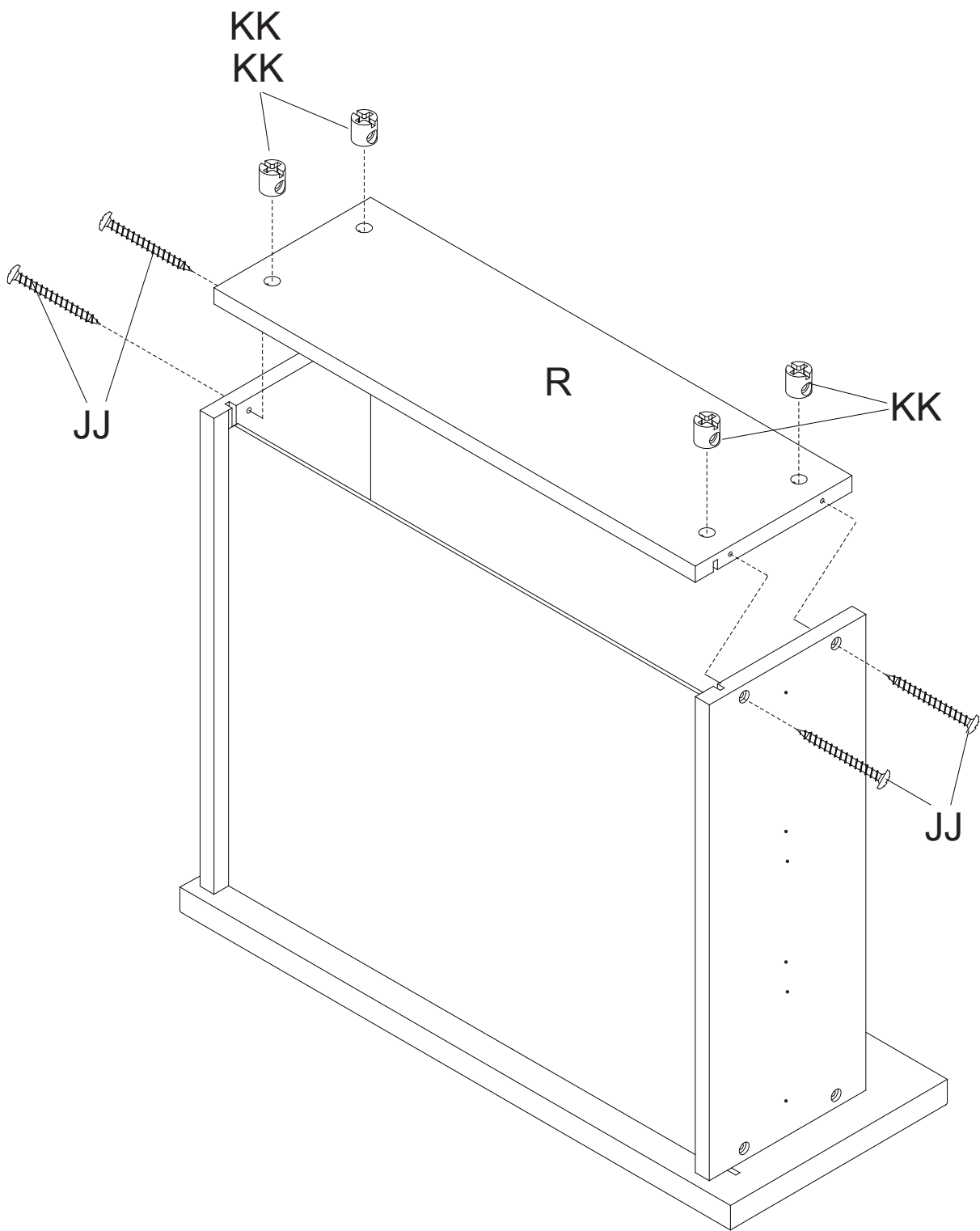

x2

STEP 14
PASO 14

Parts and tools required to complete step
Piezas y herramientas necesarias para completar este paso

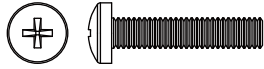

PP2 Handle Screw x2
Tornillo para Perilla

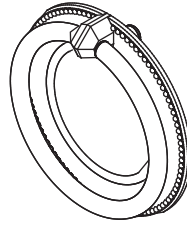

PP1 Handle x2
Manija

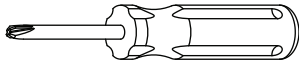

Phillips Screwdriver – Not included
Destornillidor Phillips – no incluido

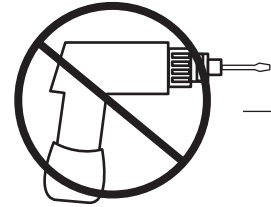

No drills necessary.
Do not use power screwdriver.

No hace falta taladrar.
No utilice destornilladores eléctricos

Attach (1) Handle (Part PP1) to Drawer Assembly using (1) Handle Screw (Part PP2). Repeat this step until both top drawers are complete.

Fije la (1) Manija (Pieza PP1) al ensamblaje de la gaveta utilizando (1) tornillo para Manija (Pieza PP2). Repita este paso hasta haber completado las 2 gavetas.

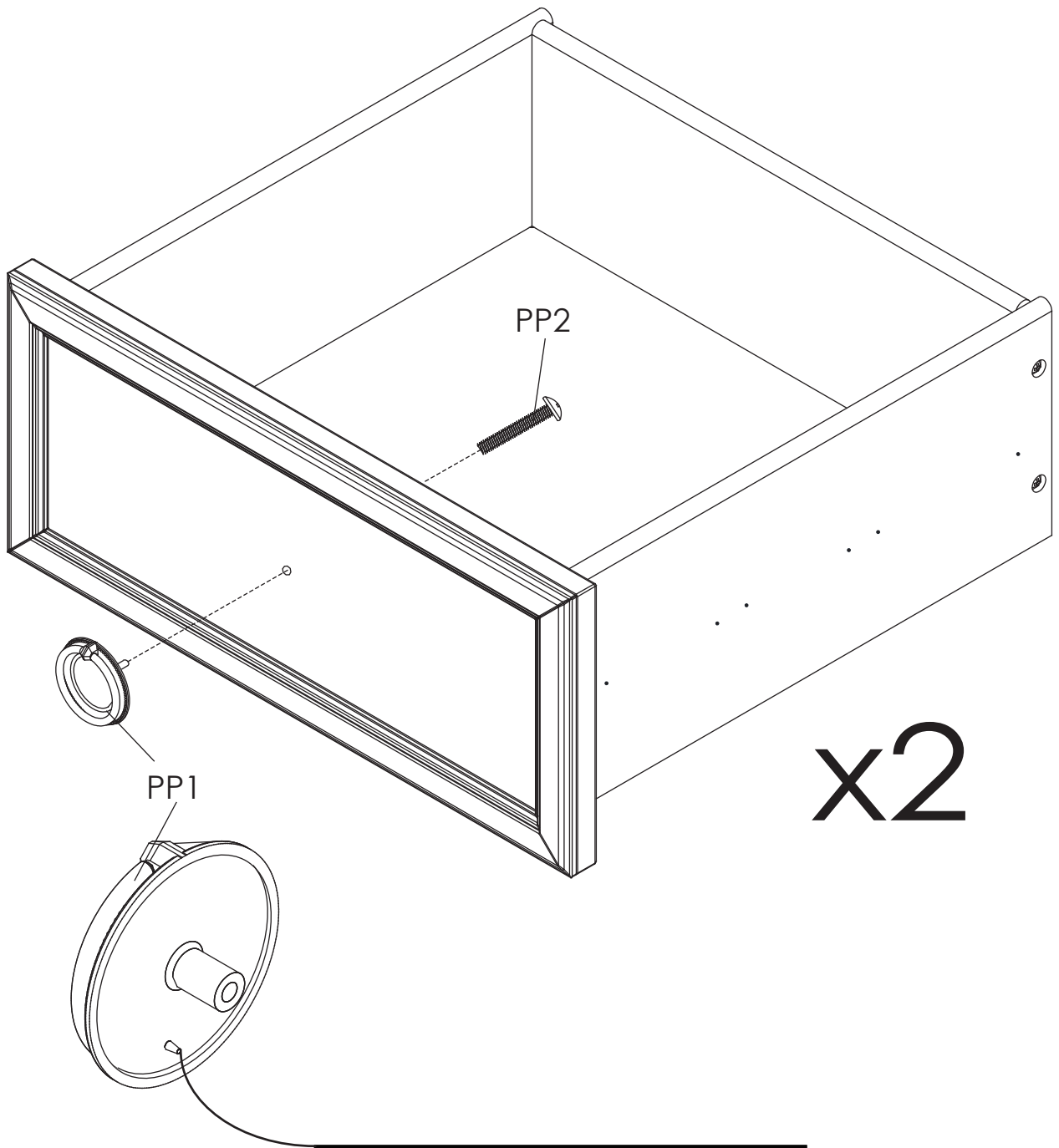

CAUTION

Align Handle BEFORE tightening.
This pin leaves a dent.

ATENCIÓN

Alinee la manija ANTES de apretar.
Este clavija deja una abolladura.

STEP 15

PASO 15

Parts and tools required to complete step

Piezas y herramientas necesarias para completar este paso

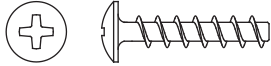

LL 20mm Screw x8
Tornillo 20mm

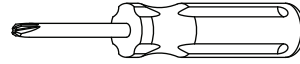

Phillips Screwdriver – Not included
Destornillidor Phillips – no incluido

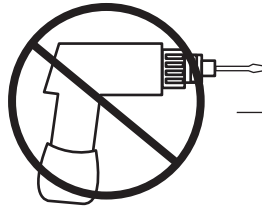

No drills necessary.
Do not use power screwdriver.

No hace falta taladrar.
No utilice destornilladores eléctricos

Slide Bottom Drawer Bottom (Part Z) into the grooves. Attach the Drawer Sides (Parts T) to the Drawer Front (Part Y) with (4) 20mm Screws (Part LL). Note: Grooves in Bottom must align. Tighten With Phillips Screwdriver. Repeat this step until (2) drawers are complete.

Deslice la parte inferior de la gaveta inferior (Pieza Z) hacia las ranuras. Fije los Barra de la gaveta (Pieza T) a la parte frontal de la gaveta (Pieza Y) utilizando (4) tornillos 20mm (Pieza LL). Nota: Las ranuras al inferior deben alinearse. Apriete utilizando un destornillador Phillips. Repitaestepaso hasta haber completado las 2 gavetas .

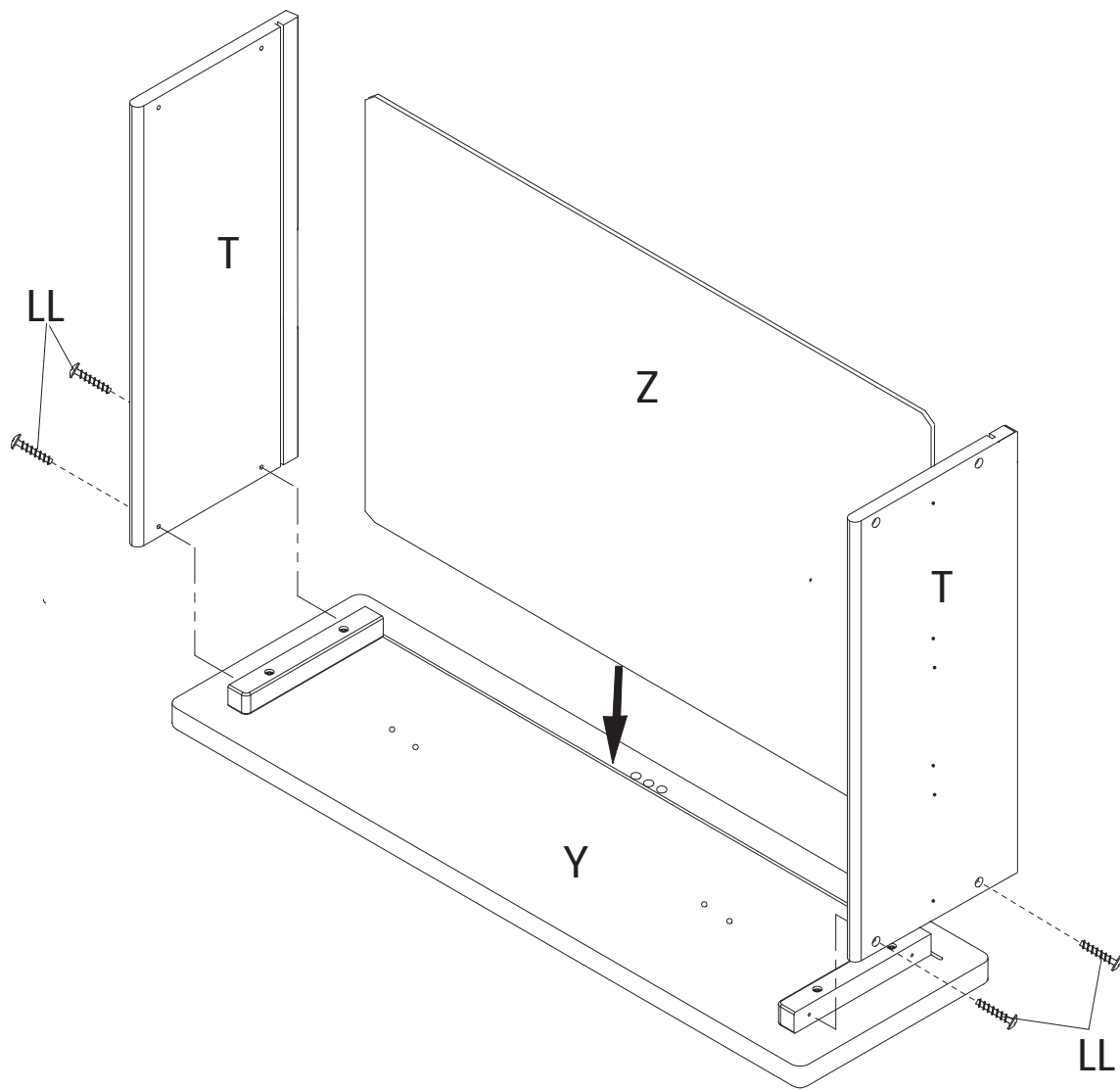

x2

STEP 16 PASO 16

Parts and tools required to complete step
Piezas y herramientas necesarias para completar este paso

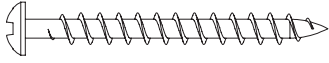

JJ

40mm Screw x10
Tornillo 40mm

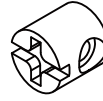

KK

Plastic Barrel Nut x10
Tuerca de Barril Plásticas

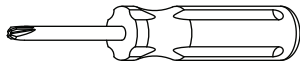

Phillips Screwdriver – Not included
Destornillidor Phillips – no incluido

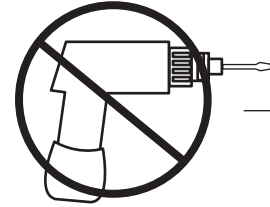

No drills necessary.
Do not use power screwdriver.

No hace falta taladrar.
No utilice destornilladores eléctricos

Install the Drawer Support (Part W) into drawer front. Attach Drawer Back (Part X) using (5) 40mm Screws (Part JJ) and (5) Plastic Barrel Nuts (Part KK), ensure the grooves at the bottom line up. Tighten With Phillips Screwdriver. Repeat this step until all 2 drawers are complete.

Instalar el soporte de la gaveta (pieza W) dentro de la gaveta . Fijar la parte posterior de la gaveta (pieza X) utilizando (5) tornillos de 40mm (pieza JJ) y (5) tuercas plásticas de barril (pieza KK). Asegurarse de que las ranuras en el fondo estén alineadas. Apriete utilizando un destornillador Phillips. Repita hasta completar las (2) gavetas.

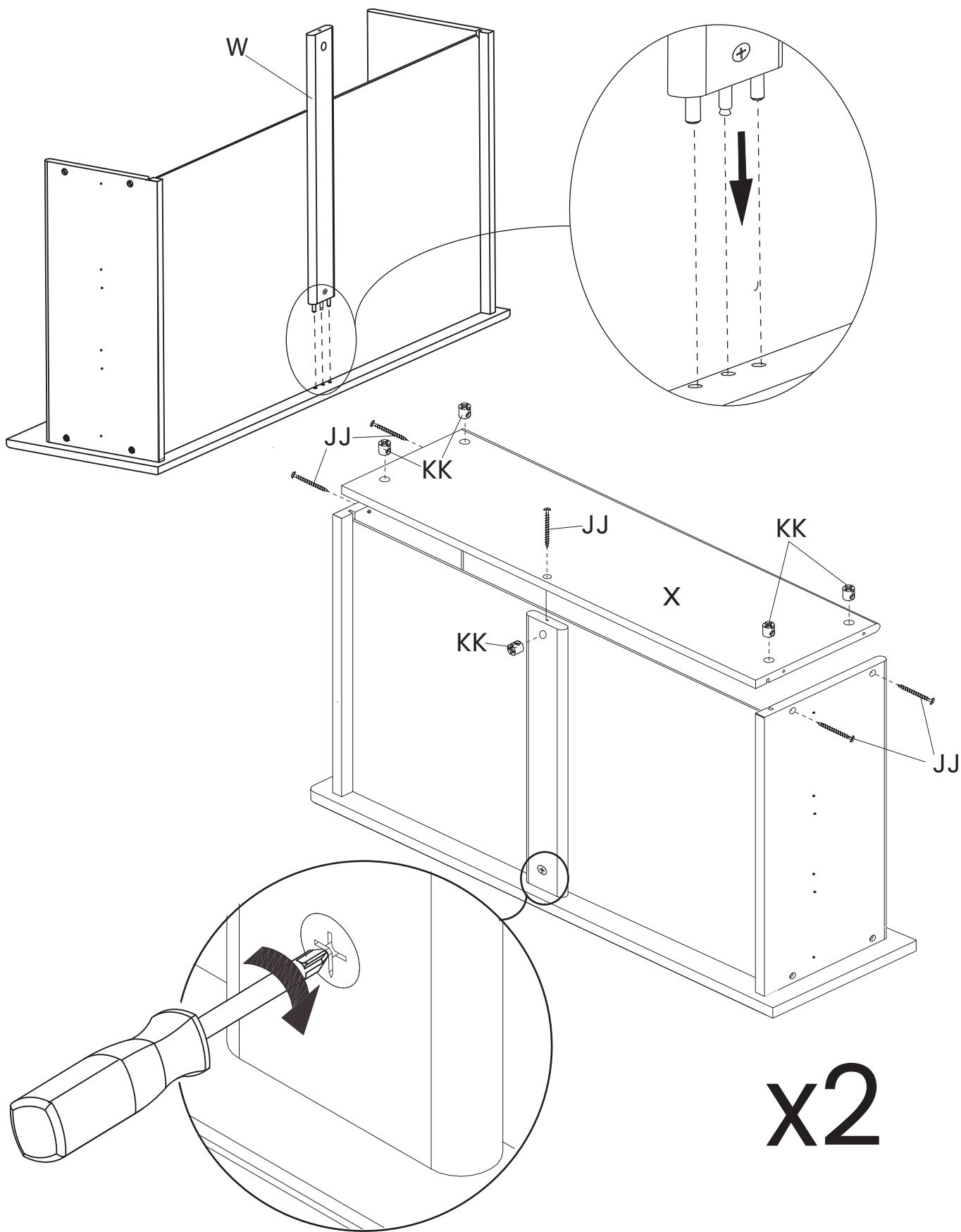

STEP 17 PASO 17

Parts and tools required to complete step
Piezas y herramientas necesarias para completar este paso

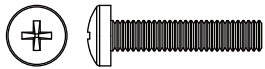

PP2 Handle Screw x4
Tornillo para Perilla

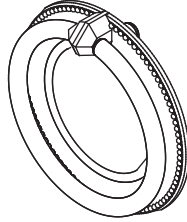

PP1 Handle x4
Manija

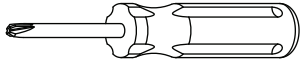

Phillips Screwdriver – Not included
Destornillidor Phillips – no incluido

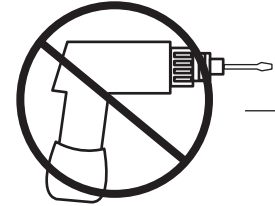

No drills necessary.
Do not use power screwdriver.

No hace falta taladrar.
No utilice destornilladores eléctricos

Attach (2) Handles (Part PP1) to Drawer Assembly using (2) Handle Screws (Part PP2). Repeat this step until both Bottom drawers are complete.

Fije la (2) Manija (Pieza PP1) al ensamblaje de la gaveta utilizando (2) tornillos para Manija (Pieza PP2). Repita este paso hasta haber completado las 2 gavetas.

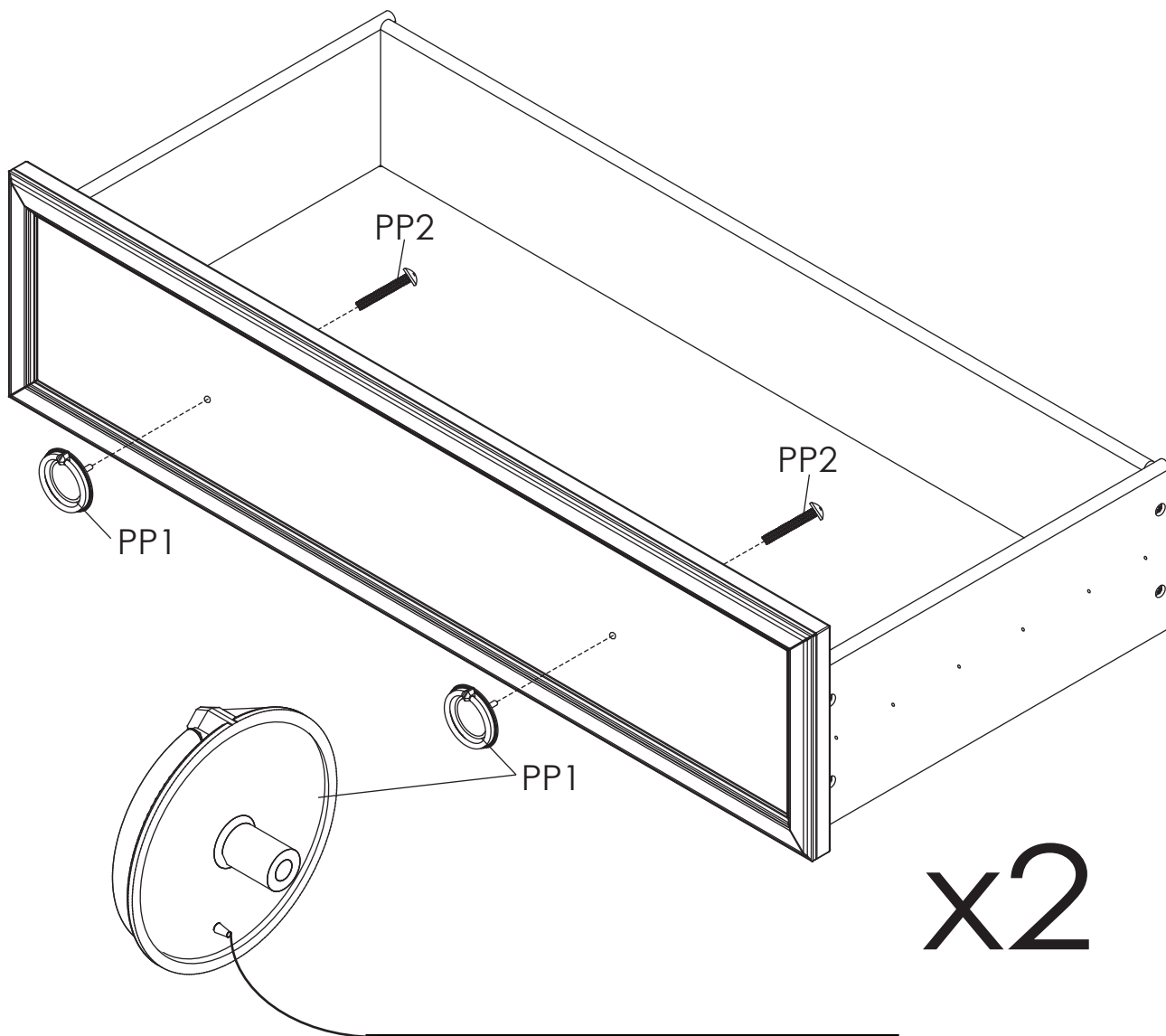

CAUTION

Align Handle BEFORE tightening.
This pin leaves a dent.

ATENCIÓN

Alinee la manija ANTES de apretar.
Este clavija deja una abolladura.

STEP 18

PASO 18

- ⚠ Only remove 1 set of runners at a time
- ⚠ Solo quite 1 juego de correedores a la vez

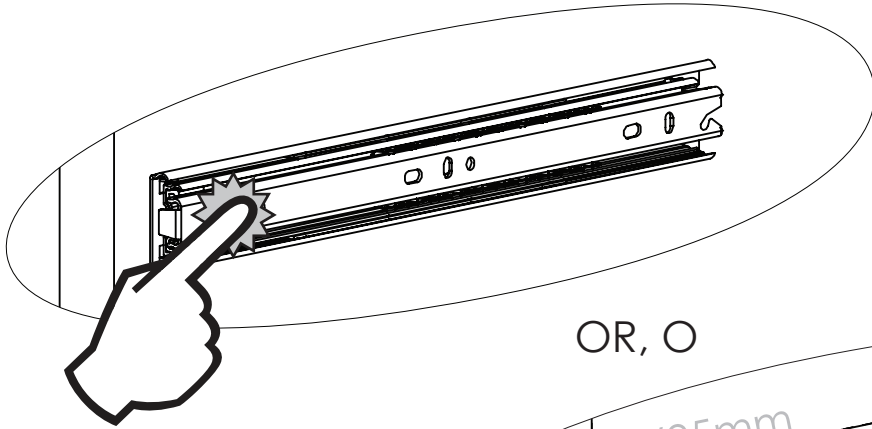
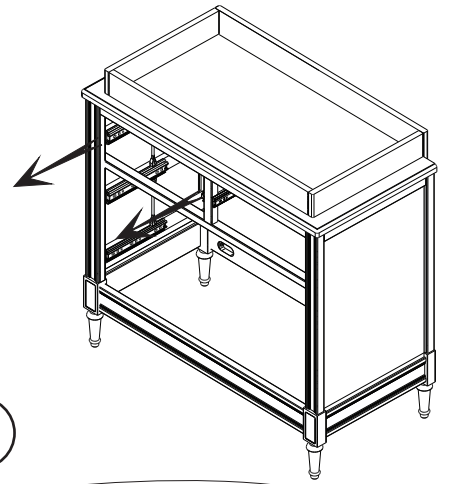

OR, O

①

Press & PULL
Empujar & SAQUE

PULL
SAQUE

Allen Wrench
Llave Allen

1" / 25mm

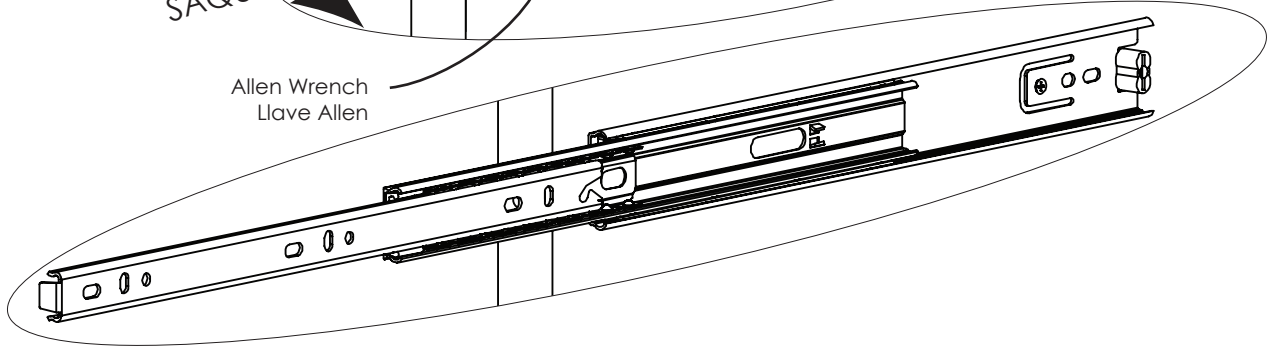

Left/Izquierdo

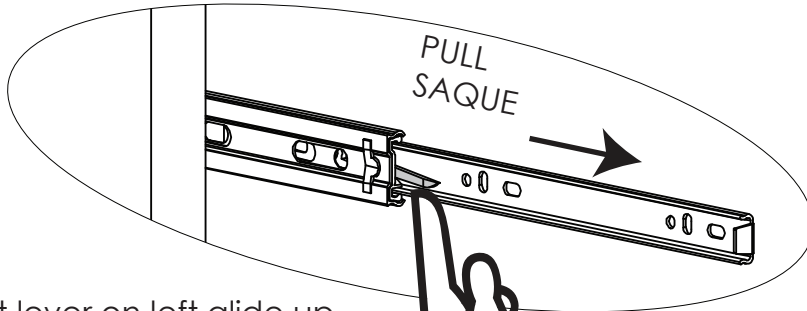

Lift lever on left glide up
Levantarse la palanca a la izquierda se desliza hacia arriba

②

Press lever on right glide down
Empujar la palanca a la derecha se desliza por



PULL
SAQUE

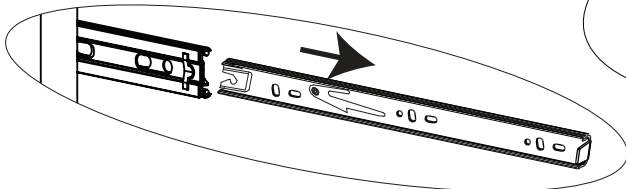

③

Right/Derecho

⚠ Do not bump pin prior to installing drawer
⚠ No golpee el pasador antes de instalar el cajón.

The silver portion of the glide must be pulled to the front of the glide when assembling the drawer into the case.

La parte plateada de la guía de la gaveta debe estar al frente de la guía cuando se está armando la cómoda.

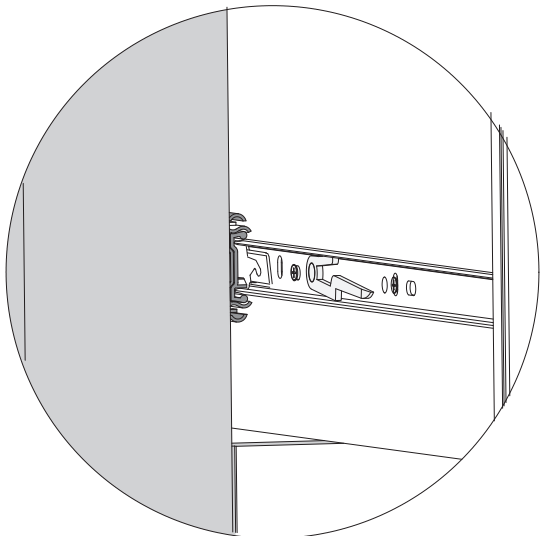
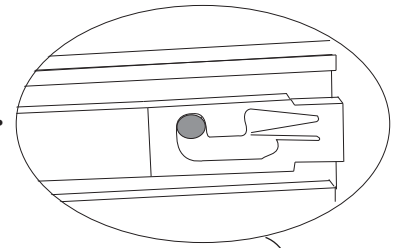
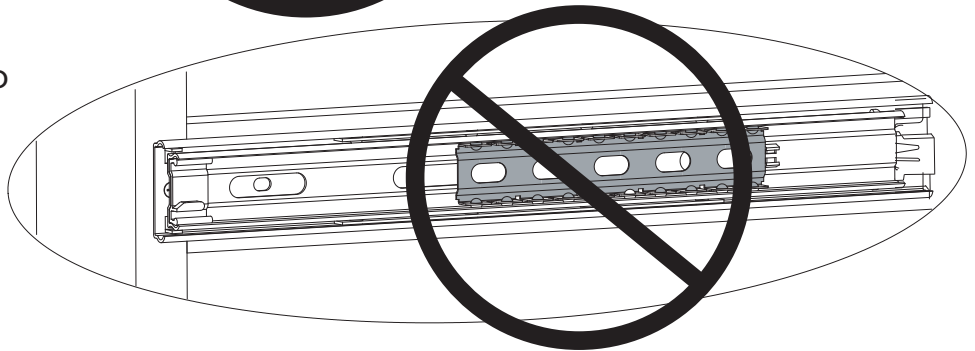
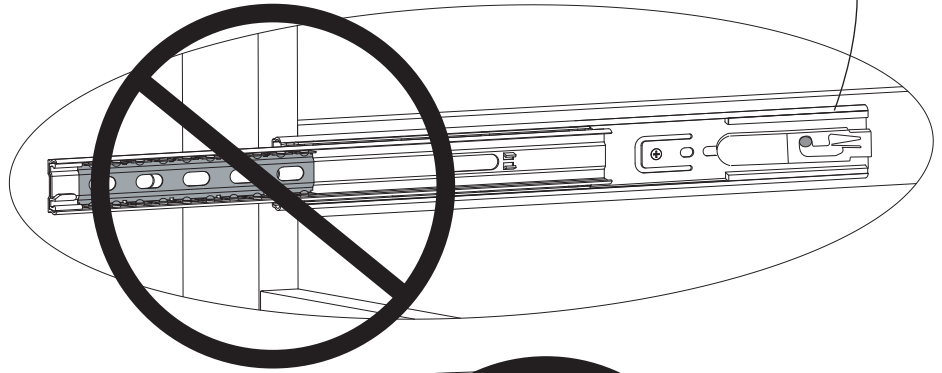
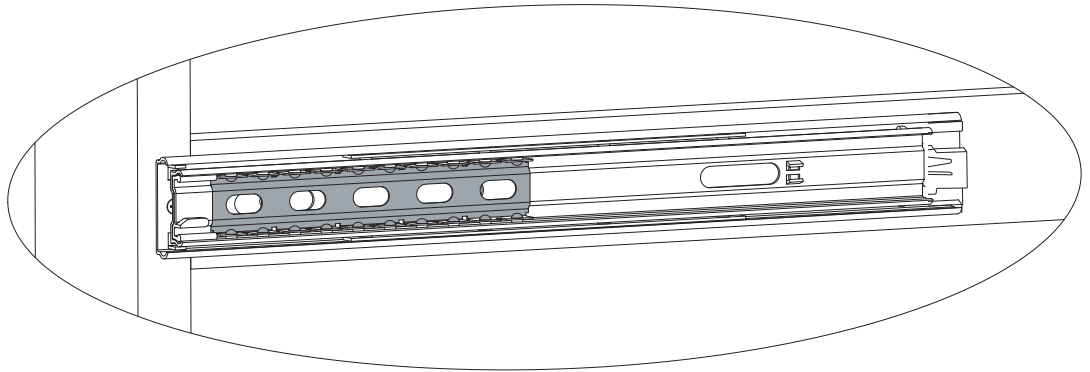

To insert drawer align male runner on drawer to female runner on case and push all the way in.

Para insertar la gaveta alinear runner mujer en la gaveta para de hombre runner case y empuje hasta el fondo.

STEP 19 PASO 19

Parts and tools required to complete step
Piezas y herramientas necesarias para completar este paso

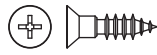

12mm Screw x24
Tornillo 12mm

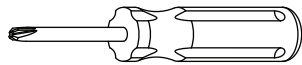

Phillips Screwdriver – Not included
Destornillidor Phillips – no incluido

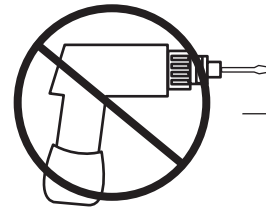

No drills necessary.
Do not use power screwdriver.

No hace falta taladrar.
No utilice destornilladores eléctricos

Attach (2) Drawer Guide outer pieces to each assembled drawer. There are pre-drilled holes in each drawer side.

- i) Place the end of the Drawer Guide with the tab against the Drawer front, then align the holes in the Guide to the holes in the Side, tab should remain very close to the Drawer Front.
- ii) Attach the Drawer Guide with (3) screws (Part WW). Install the screws in the order shown on the next page (1st, 2nd, 3rd).. Tighten with a Phillips Screwdriver.
- iii) repeat with the other Drawer Side.
- iv) Install the drawer following the instructions on page 54 and 55.
- v) Repeat until all (4) Drawers are complete.

Fije (2) piezas externas de guía de gaveta en cada gaveta ensamblada. Hay agujeros pre taladrados en cada costado de la gaveta.

- i) Coloque el extremo de la guía de gaveta, con la lengüeta contra la parte frontal de la gaveta, luego alinee la guía con los agujeros del costado; la lengüeta debe quedar muy cerca de la parte frontal de la gaveta.
- ii) Fije la guía de gaveta con (3) tornillos (Pieza WW). Instale los tornillos en el orden que se muestra en la página siguiente (1st, 2nd, 3rd). Apriete con un destornillador Phillips.
- iii) Repita con el otro costado de la gaveta.
- iv) Instale el gaveta siguiendo las instrucciones de las páginas 54 y 55.
- v) Repita hasta completar las (4) gavetas

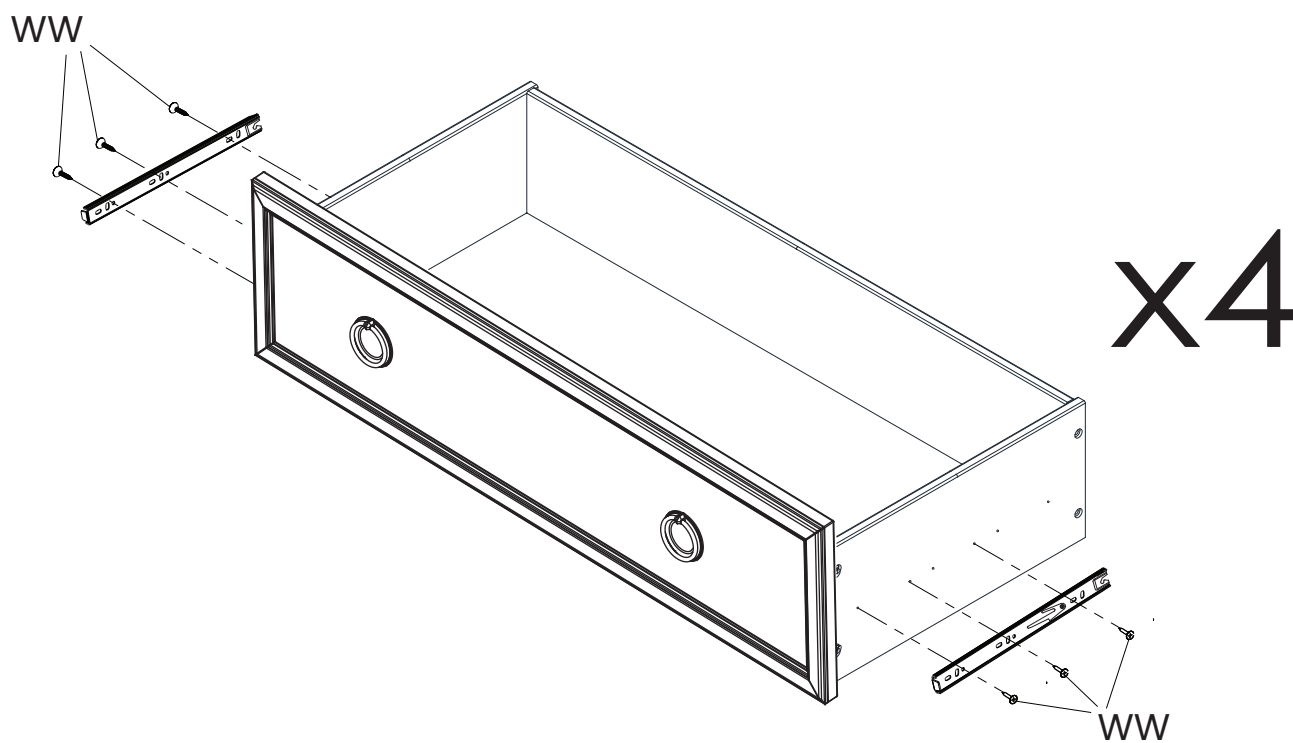
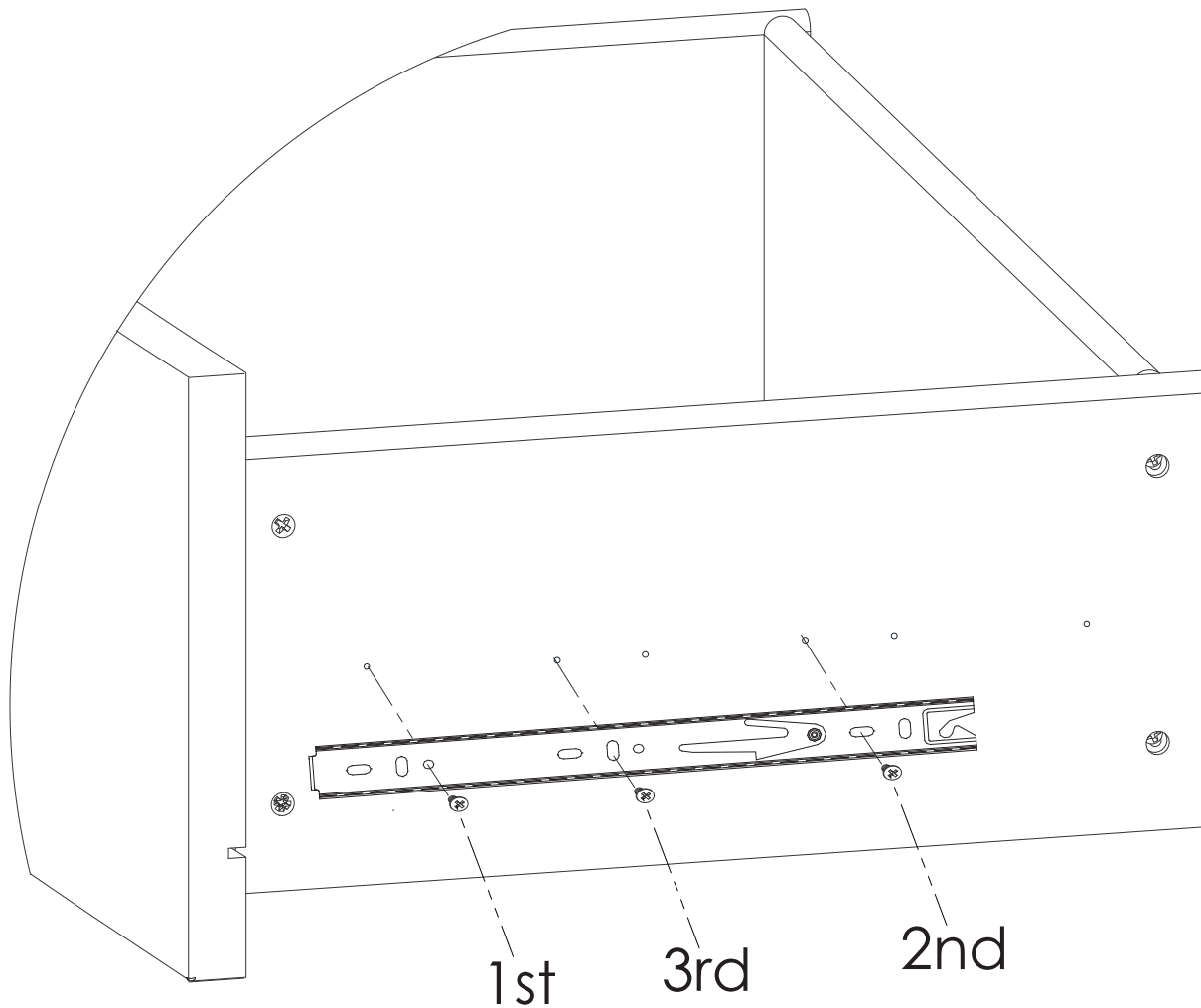

STEP 20
PASO 20

WARNING Label
Etiqueta de **ADVERTENCIA**

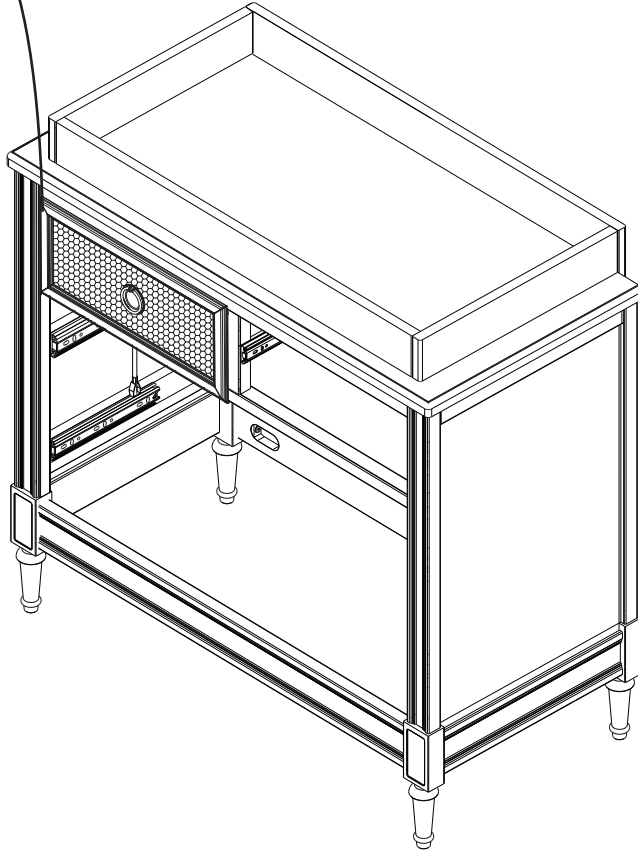

Install the drawers in the case body. Carefully align the Drawer Guides on each drawer with the Drawer Guides on the case. Push the drawer STRAIGHT in until it "clicks". Check that each side is fully secure. Open and close the drawer to ensure smooth operation. Changing the locations may improve fit or performance.

Instale las gavetas en el cuerpo del mueble. Alinee cuidadosamente las guías de gaveta en cada una de ellas con las guías del cuerpo del mueble. Presione la gaveta EN LÍNEA RECTA hasta que haga "clic". Revise que cada lado esté bien asegurado. Abra y cierre la gaveta para asegurarse de que funciona correctamente. Cambiar las ubicaciones podría mejorar el funcionamiento.

See pages 50
Ver páginas 50

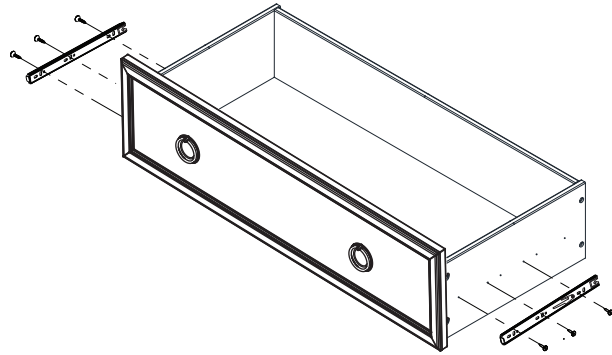
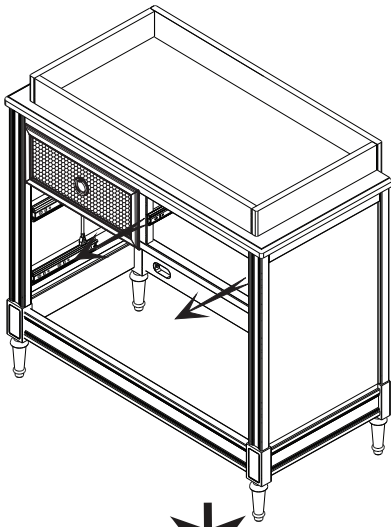

See pages 52 and 53
Ver páginas 52 y 53.

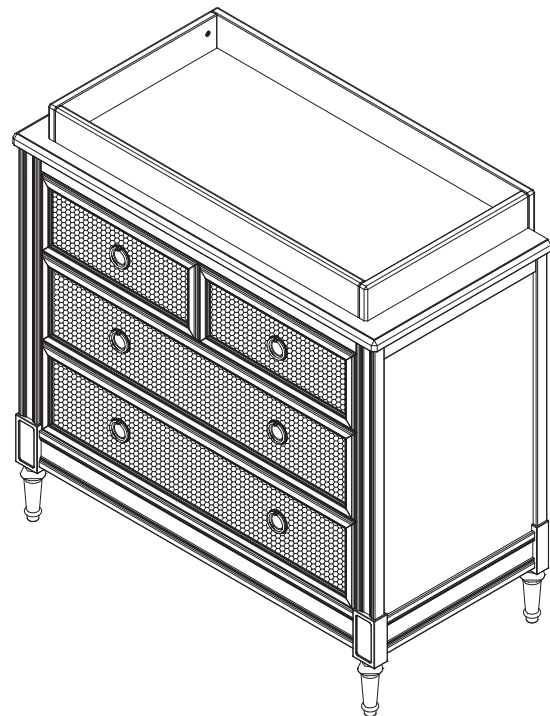
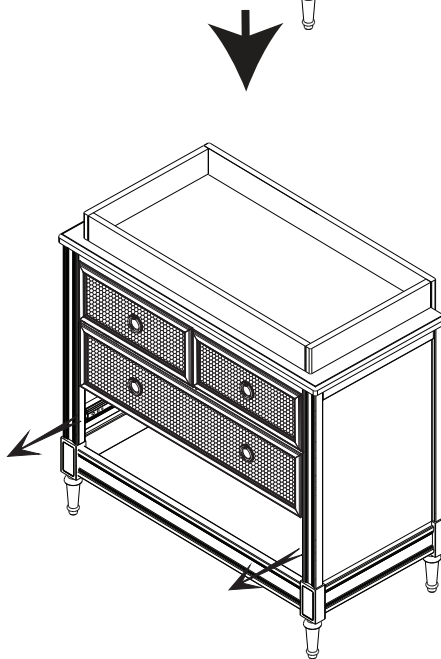
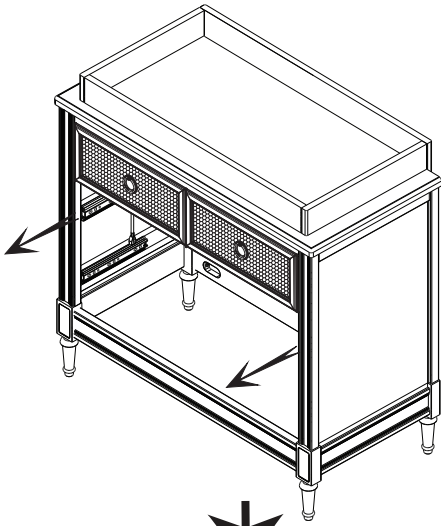

Limited Warranty:

This Delta Product is warranted to be free from defects for a period of 90 days from the date of purchase under normal use. If a product is defective during this period, we will at our option repair or replace the defective part or product. This limited warranty extends only to the original retail purchaser and is valid only when supplied with proof of purchase, or if received as a gift, when the registration is on file with Delta. This limited warranty does not cover the following:

- Products purchased as floor models or samples.
 - Items purchased on an “as-is” basis, as a second hand product, or as a resale product.
 - Items purchased at a Final sale, a “Going out of Business” sale or a Liquidation sale.
- This limited warranty gives you specific legal rights and you may also have other rights which vary from state to state.

To register your product

for important safety alerts and updates to your product please visit
www.deltachildren.com

To report a problem

please log on to www.deltachildren.com/help

Date of Purchase: _ _ _ _ _ (you should also keep your receipt)

Garantía Limitada:

Este Producto Delta está garantizado de estar libre de defectos por un período de 90 días a partir de su adquisición, bajo uso normal. Si un producto tiene defectos durante este período, Nosotros tomaremos la opción de reparar o reemplazar la pieza defectuosa del producto. Esta garantía limitada se otorga únicamente al comprador original y es válida solamente cuando se proporciona una prueba de compra, o si el producto fue recibido como un regalo, debe haber sido registrado con Delta. Esta garantía limitada del fabricante no cubre lo siguiente:

- Productos comprados como exhibiciones de la tienda o muestras.
- Artículos comprados como “tal como está”, productos de segunda mano o reventa de los productos.
- Artículos comprados como “venta final”, “ventas de tiendas que están quebrando” o ventas por liquidación.

Esta garantía limitada le otorga derechos legales específicos y también puede tener otros derechos que varían de un estado a otro.

Para registrar su producto

para alertas importantes de seguridad y estar al tanto sobre novedades de su producto por favor visite
www.DeltaChildren.com

Para reportar cualquier problema

por favor entre a www.DeltaChildren.com/help

Fecha de Compra: _ _ _ _ _ (debe además mantener su recibo)

SAFETY LEADERS

Visit Deltachildren.Com/Pages/Leaders-In-Safety for more information

SAFE MATERIALS

Safe products start with safe materials. We test all of our products to create the safest and healthiest environment for your baby.



PRODUCTS YOU CAN TRUST

We have 8 cutting edge safety labs around the world where we test our products above and beyond the industry standards. All of our dressers are engineered to meet or exceed ASTM Furniture Safety Standards.



WE GO ABOVE & BEYOND

To protect your children, Delta Children dressers are tested to meet the requirements of the industry tip over test set forth by ASTM. For additional security, we strongly recommend that all dressers in you home be anchored; all Delta Children dressers include a wall anchor.



LÍDERES EN LA SEGURIDAD

Visite Deltachildren.Com/Pages/Leaders-In-Safety para más información

MATERIALES SEGUROS

Los productos seguros se hacen con materiales seguros. Ponemos a prueba todos nuestros productos para crear el ambiente más seguro y saludable para su bebé.



PRODUCTOS CONFIABLES

Tenemos 8 laboratorios de seguridad de alta tecnología donde probamos nuestros productos mas allá de los estándares de la industria. Todos nuestros tocadores están diseñados para cumplir o exceder los estándares de seguridad ASTM de muebles.



ESTAMOS POR ENCIMA Y MÁS ALLÁ

Para proteger a sus niños, los tocadores de Delta Children son sometidos a pruebas para que cumplan los requisitos ASTM establecidos de la industria en cuanto a volcamientos se refiere.

Para seguridad adicional, recomendamos enfáticamente que todos los tocadores de su casa estén fijos: todos los tocadores de Delta Children incluyen un anclaje de pared.



POR QUÉ ELEGIR A DELTA CHILDREN?

Visita Deltachildren.Com/Pages/Our-Story para más información

DELTA LIDERA

1 de cada 2 niños en los EE.UU duerme en nuestros productos

DELTA DONA

10% de nuestros ingresos está destinado a mejorar la vida de los niños

A DELTA LE IMPORTA

Hacemos pruebas por encima de los estándares de seguridad de la industria

DELTA ESTÁ DEDICADA

Nuestra empresa familiar ha estado siempre presente para su familia desde 1968

DELTA CRECE CON USTEDES

Tenemos productos para cada edad y etapa

Más De 50 Años De Seguridad, Estilo E Innovación

Bienvenido a la **FAMILIA DELTA**

Aquí Está Nuestro Regalo Para Usted

10% OFF

Su Próxima Compra En DeltaChildren.com

UTILICE EL CÓDIGO:
DELTA10

PRODUCTOS PARA CADA EDAD Y ETAPA



CUNAS



COSAS PARA BEBÉ



SILLA



MOISÉS



COLCHÓN



CARRIOLAS

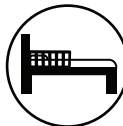

CAMA PARA NIÑO



CUARTO DE JUGAR



CAMA SENCILLA



CONTENEDORES



TOCADORES

NUESTRA FAMILIA DE LAS MEJORES MARCAS



MÁS DE 50 AÑOS DE SEGURIDAD, ESTILO E INNOVACIÓN

WHY CHOOSE DELTA CHILDREN?

Visit Deltachildren.Com/Pages/Our-Story for more information

<p>DELTA LEADS 1 Out Of 2 Children In The U.S. Sleep In Our Products</p>	<p>DELTA GIVES 10% Of Our Profits Go Toward Improving The Lives Of Children</p>	<p>DELTA CARES We Test Above & Beyond Industry Safety Standards</p>	<p>DELTA IS DEDICATED Our Family-Run Company Has Been There For Your Family Since 1968</p>	<p>DELTA GROWS WITH YOU We Have Products For Every Age And Stage</p>	<p>Over 50 Years Of Safety, Style & Innovation</p>
---	--	--	---	---	---

Welcome to the **DELTA FAMILY**
Here's a Gift From Us To You











10% OFF

Your Next Purchase From DeltaChildren.com

USE CODE:
DELTA10

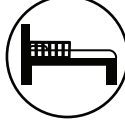
*Exclusions Apply
*Subject to Change

PRODUCTS FOR EVERY AGE AND STAGE

 CRIBS LITS POUR BÉBÉ CUNAS	 STROLLERS ÉQUIPEMENT POUR BÉBÉ COSAS PARA BEBÉ	 GLIDERS CHAISE SILLA	 BASSINETS COUFFINS MOISÉS	 MATRESSES MATELAS COLCHÓN	
 BABY GEAR POUSSETTES CARRIOLAS	 TODDLER BEDS LITS POUR ENFANT CAMA PARA NIÑO	 PLAYROOM FURNITURE SALLE DE JEUX CUARTO DE JUGAR	 TWIN BEDS LITS UNE PLACE CAMA SENCILLA	 BINS & ORGANIZERS PANIERES CONTENEDORES	 DRESSERS COMMODOES TOCADORES

OUR FAMILY OF TOP BRANDS



OVER 50 YEARS OF SAFETY, STYLE, AND INNOVATION