



3 Drawer Dresser

Read all instructions before assembly and use.

KEEP INSTRUCTIONS FOR FUTURE USE.



To Make Assembly Even Easier Watch Video Here!



For Questions or to Contact Us:

DeltaChildren.com/Help

If unable to access website, please email wcs@DeltaChildren.com

Expect longer response times via email.



Style #: _____

 Lot: _____

REV Date: _____

Before contacting Delta Consumer Experience Center please ensure this information matches the information found on the label on the Back Panel.



ADULT ASSEMBLY REQUIRED

Due to the presence of small parts during assembly, keep out of reach of children until assembly is complete.

This product is not intended for institutional or commercial use.



Cómodade 3 Gavetas

Lea todas las instrucciones antes de ensamblar y usar.

MANTENGA LAS INSTRUCCIONES PARA SU USO FUTURO.



Para facilitar más aun el ensamblaje ver el video aquí



Para preguntar o para contactarnos :

DeltaChildren.com/Help

Si no puede acceder el sitio web, por favor envíenos un email a wcs@DeltaChildren.com

El tiempo de espera para respuestas será más largo por email.

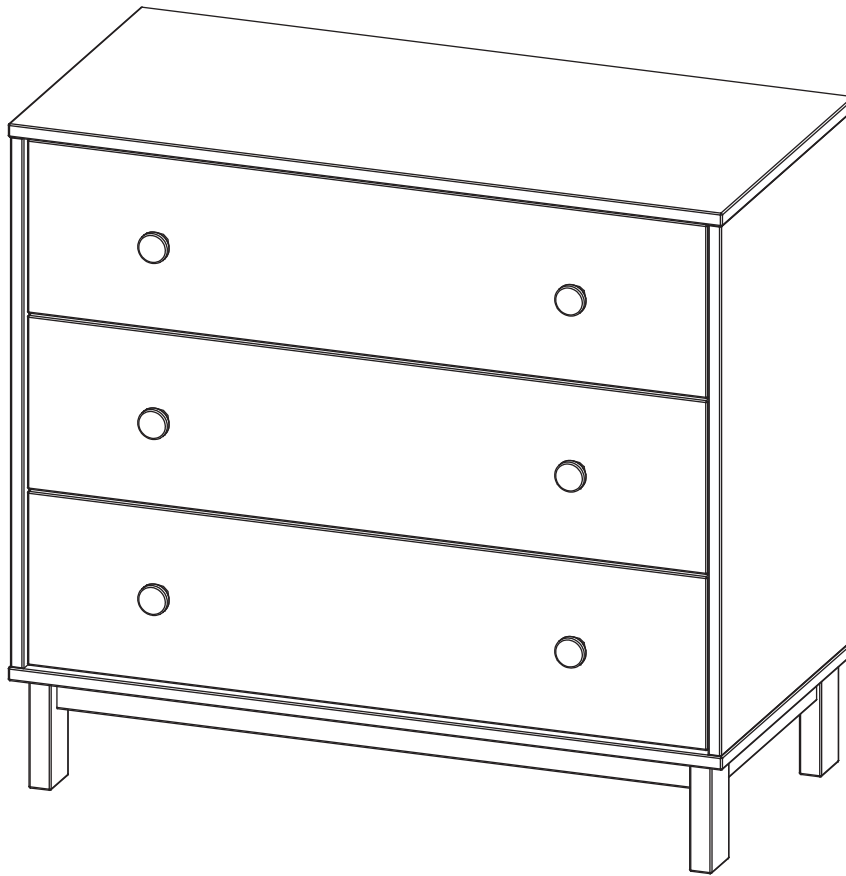

DEBE SER ENSAMBLADO POR UN ADULTO

Debido a la presencia de piezas pequeñas durante el ensamblaje, mantenga fuera del alcance de los niños hasta que complete el ensamblaje.

Antes de contactar el Centro de Experiencia del Consumidor de Delta por favor asegúrese de que la información de la primera página coincida con la información que se encuentra en la etiqueta ubicada en el panel trasero.

Este producto no esta hecho para uso institucional o comercial.

BABY SAFE SLEEP TIPS

Visit Deltachildren.Com/Pages/Crib-Safety-Tips for more information



Read all warnings and follow all instructions.



DO NOT place any items in the crib.



The safest place for your baby to sleep is in a JPMA Certified crib.



Pillows and blankets have caused infants to suffocate, **NEVER** use in a crib.

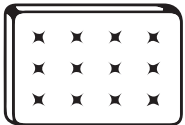

Your baby should sleep on a firm mattress.



NEVER place the crib near a window or any wall hangings.



Adult beds are not safe for babies: **NEVER** co-sleep.



Missing or broken parts, any questions?
www.DeltaChildren.com/Help



AAP RECOMMENDS:

Always lay your baby on its back to sleep.

Consult your doctor.

FURNITURE SAFETY TIPS

Visit Deltachildren.Com/Pages/Leaders-In-Safety for more information

SERIOUS OR FATAL CRUSHING INJURIES
CAN OCCUR FROM FURNITURE TIP-OVER.



Read all warnings and follow all instructions.



NEVER open more than one drawer at a time.



ALWAYS use provided tipover restraints.



DO NOT leave drawers open when not in use.



DO NOT set TV's or other heavy objects on the top of bedroom or nursery furniture.



NEVER allow children to climb or hang on drawers, doors, or shelves.



Place heaviest items in the lowest drawers.



Missing or broken parts, any questions?
www.DeltaChildren.com/Help

CONSEJOS PARA UN SUEÑO SEGURO PARA LOS BEBÉS

Visite Deltachildren.Com/Pages/Crib-Safety-Tips para obtener más información



Lea todas las advertencias y siga todas las instrucciones.



NO coloque artículos en la cuna.



El lugar más seguro para que su bebé duerma es una cuna con certificación JPMA.



Las almohadas y frazadas han provocado asfixia en menores; por lo tanto, **JAMÁS** se deben utilizar en una cuna.



Su bebé debe dormir sobre un colchón firme.



JAMÁS coloque la cuna cerca de una ventana o elementos colgados en las paredes.



Las camas para adultos no son seguras para los bebés: **JAMÁS** duerma con ellos.



¿Le faltan piezas o vienen rotas?
www.DeltaChildren.com/Help



APP RECOMIENDA:

Haga que su bebé duerma siempre boca arriba.

Consulte a su médico.

CONSEJOS DE SEGURIDAD SOBRE MUEBLES

Visite Deltachildren.Com/Pages/Leaders-In-Safety para obtener más información

PUEDEN PRODUCIRSE LESIONES GRAVES O MORTALES
POR APLASTAMIENTO AL VOLCARSE MUEBLES.



Lea todas las advertencias y siga todas las instrucciones.

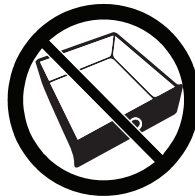

NUNCA abra más de un cajón al mismo tiempo.



Utilice **SIEMPRE** las retenciones contra volcamiento incluidas



NO DEJE cajones abiertos si no los está utilizando.



NO posicione televisores u otros objetos pesados sobre la cama o muebles para infantes.



NUNCA permita que los niños trepen sobre cajones, puertas o baldas de estantería ni que se cuelguen de ellos.



Coloque los artículos de mayor peso en los cajones inferiores.



¿Le faltan piezas o vienen rotas?
www.DeltaChildren.com/Help

⚠ WARNING



Children have died from furniture tipover. To reduce the risk of furniture tipover:

- ALWAYS install tipover restraint provided.
- NEVER put a TV on this product.
- NEVER allow children to stand, climb or hang on drawers, doors, or shelves.
- NEVER open more than one drawer at a time.
- Place heaviest items in the lowest drawers.



NOTES ON ASSEMBLY:

- During the assembly process whenever using screws or bolts, check each by placing the screw/bolt on the diagram of the item which is drawn actual size and design. Be sure to use the proper size and shape specified in the instructions.
- To assemble this unit you may be required to place the unit on it's side and face. It is strongly recommended that assembly is done on a soft, non-abrasive surface to avoid damaging the finish.

NOTES ON USE:

Keep children and others safe by following these simple rules:

- **Do not** allow any child to play on furniture
- **Do not** allow climbing on any piece of furniture.
- **Do not** allow hanging from any piece of furniture.
- Always monitor your child's activity when in the nursery.

NOTES ON CARE AND MAINTENANCE:

- **Do not** scratch or chip the finish.
- Inspect the product periodically, contact Delta Children's Products for replacement parts or questions.
- **Do not** store the product or any parts in extreme temperatures and conditions such as a hot attic or a damp, cold basement. These extremes can cause a loss of structural integrity.
- To preserve the luster of the high quality finish on your product, it is recommended to place a doily or felt pad under any items you place on the finish.
- Clean with a damp cloth, then a dry cloth to preserve the original luster and beauty of this fine finish.
- Do not** use abrasive chemicals.
- Do not** spray cleaners directly onto furniture.
- Lift slightly when moving on carpeting to prevent leg breakage.
- Use of a vaporizer near furniture will cause wood to swell and finish to peel.

⚠️ ADVERTENCIA



Han muerto niños debido a volcaduras de muebles. Para prevenir volcaduras:

- Instalar SIEMPRE el dispositivo anti-volcaduras incluido.
- No colocar NUNCA un televisor en este producto.
- Nunca permita que los niños trepen sobre cajones, puertas o baldas de estantería ni que se cuelguen de ellos.
- Nunca abra más de un cajón al mismo tiempo.
- Coloque los artículos de mayor peso en los cajones inferiores.



INFORMACIÓN SOBRE EL MONTAJE:

- Durante el proceso de montaje, ya utilice pernos o tornillos, compruebe cada uno de ellos colocando el perno/tornillo en el diagrama del artículo donde está dibujado el tamaño y el diseño real. Asegúrese de que utiliza el tamaño y la forma adecuada que especifican las instrucciones.
- Para montar esta unidad, puede que se le solicite que coloque la unidad de lado y de cara. Se recomienda encarecidamente que realice el montaje sobre una superficie no abrasiva (Como la envoltura de embalaje de espuma) para evitar dañar el acabado.

INFORMACIÓN SOBRE EL USO:

Mantenga a los niños y otras personas a salvo siguiendo estas sencillas reglas:

- **No permita** que ningún niño juegue sobre muebles.
- **No permita** que nadie trepe sobre un mueble.
- **No permita** que nadie se cuelgue de un mueble.
- Vigile siempre la actividad de su hijo cuando se encuentre en su cuarto.

NOTAS SOBRE SU CUIDADO Y MANTENIMIENTO:

- **No** arañe ni desconche el acabado.
- Inspeccione el producto con regularidad, póngase en contacto con Delta Children's Products para el recambio de partes o para formular preguntas.
- **No** guarde el producto ni ninguna de sus partes a temperaturas ni en condiciones extremas como un ático caluroso o un sótano húmedo y frío. Estos extremos pueden provocar una pérdida de integridad estructural.
- Para preservar el brillo del acabado de alta calidad que recubre su producto, se recomienda que coloque un paño o una almohadilla de fieltro debajo de cualquier objeto que coloque sobre el acabado.
- Límpielo con un trapo húmedo y luego con uno seco para preservar el brillo y la belleza originales de este fino acabado.
- No** utilice productos químicos abrasivos.
- No** pulverice limpiadores directamente sobre el mueble.
- Elévelo ligeramente cuando lo mueva sobre alfombras o moqueta para evitar que se rompan las patas.
- El uso de vaporizadores cerca de muebles puede provocar que la madera se hinche y acabe desconchándose.

PARTS: MAKE SURE THAT ALL PRE-ASSEMBLED PARTS ARE TIGHT
PIEZAS: ASEGÚRESE DE QUE TODAS LAS PIEZAS PRE-ENSAMBLADAS ESTÁN BIEN APRETADAS.

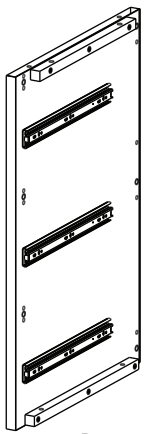

B

Left Side x1
Lado izquierdo
#43587

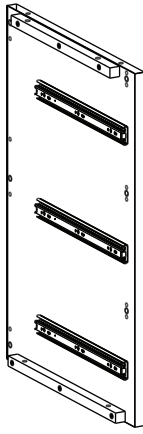

C

Right Side x1
Lado derecho
#43588

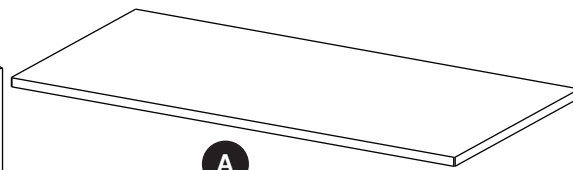

A

Top Panel x1
Panel superior
#42996

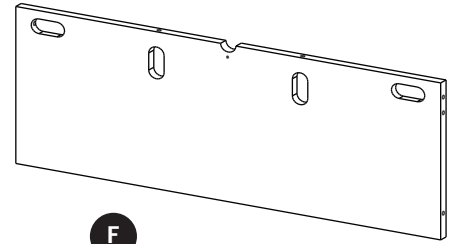

F

Top Back Rail x1
Barra trasero superior
#43589



E

Top Front Rail x1
Barra frontal superior
#43000

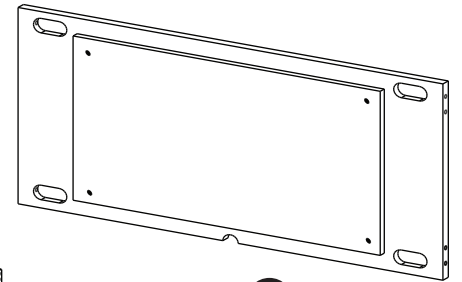

D

Bottom Back Rail x1
Barra trasero inferior
#43003



K

Base Rail x1
Barra de la Base
#43004



H

Drawer Rail x2
Barra de la gaveta
#43001

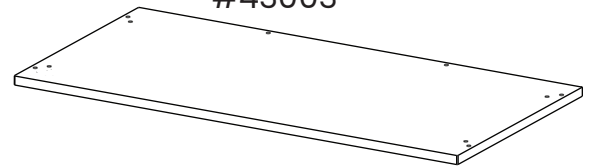

R

Bottom Panel x1
Panel inferior
#42999

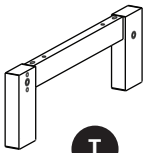

T

Left Base Side x1
Lado Izquierdo de la Base
#43005

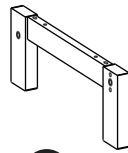

N

Right Base Side x1
Lado Derecho de la Base
#43006



S

Corner Brace x2
Refuerzo para la esquina
#43007

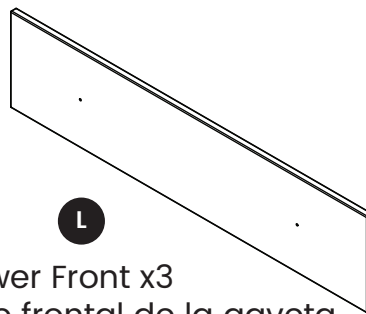

L

Drawer Front x3
Parte frontal de la gaveta
#43011

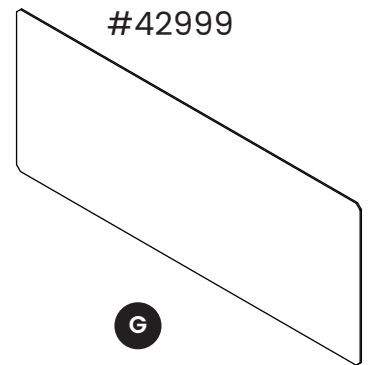

G

Drawer Bottom x3
Fondo de la gaveta
#43010

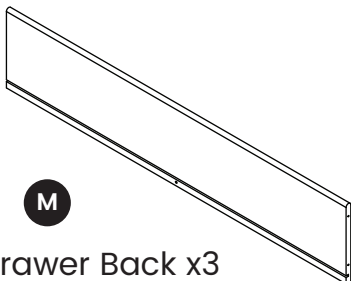

M

Drawer Back x3
Trasera de la gaveta
#43009

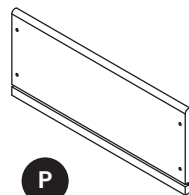

P

Drawer Side x6
Barra de la gaveta
#43590

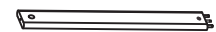

W

Drawer Support x3
Soporte de la Gaveta
#43293

PARTS: HARDWARE KITS PART#43012

PIEZAS: EL KIT DE HERRAMIENTAS - PIEZA #43012

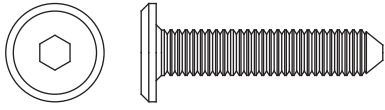

GG 30mm Bolt x12
Perno 30mm

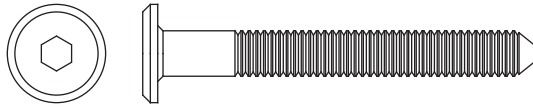

CC 50mm Bolt x26
Perno 50mm



BB Crescent Washer x16
Arandela de media luna

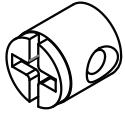

KK Plastic Barrel Nut x15
Tuercacilíndricaplástica



FF Φ 8x30mm Dowel x32
Pasador Φ 8x30mm

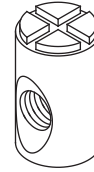

MM 10x15mm Barrel Nut x2
Tuerca cilíndrica 10x15mm

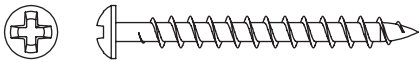

NN 40mm Screw x15
Tornillo 40mm

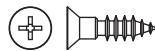

EE 12mm Screw x18
Tornillo 12mm

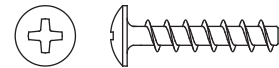

LL 20mm Screw x12
Tornillo 20mm

PP Knob / Perilla x6
#42995

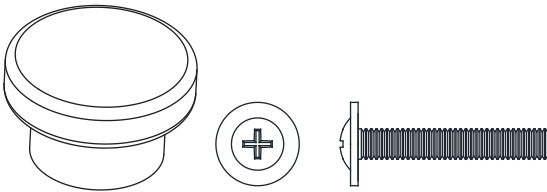

PP1 Knob
Perilla

PP2 Knob Screw
Tornillo para Perilla

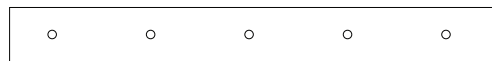

ZZ Wall Strap x1
Abrazadera

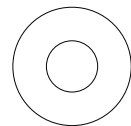

TT Washer x2
Arandela

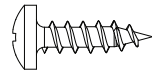

YY Short Screw x1
Tornillo corto

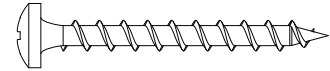

XX Long Screw x1
Tornillo Largo

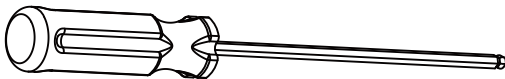

M4 Ballend Screwdriver
destornillador M4 con cabeza de bola



M4 Allen Wrench
Llave Allen M4

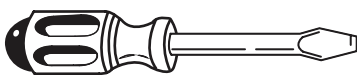

Flat Screwdriver – Not included
destornillador de cabeza plana – no incluido



Phillips Screwdriver – Not included
Destornillador Phillips – no incluido

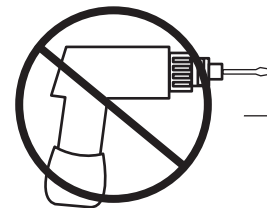

No drills necessary.
Do not use power screwdriver.

No hace falta taladrar.
No utilice destornilladores eléctricos

Hardware System - Review Before Assembly Revise Antes De Armar- Elementos De Fijacion Y Ensamble

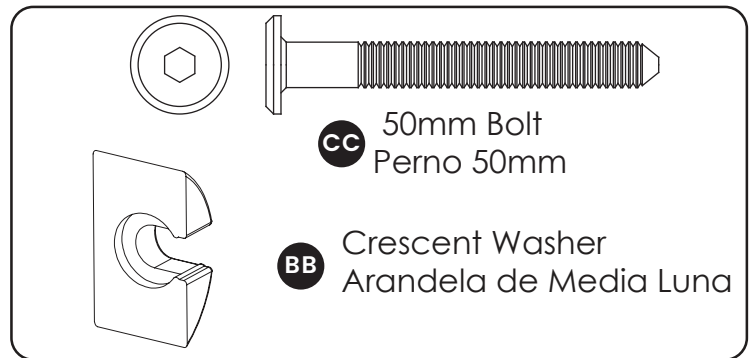
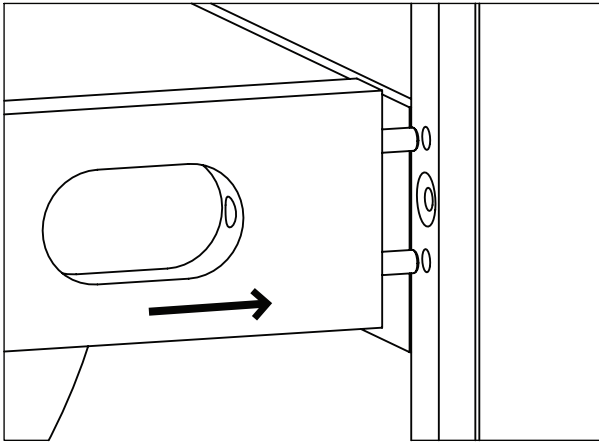

1. Insert the Dowels in the Rail into the holes in the Post.

1. Inserte los pasadores del Riel en los agujeros del Poste.

2. Insert the Bolt into the slot. Turn clockwise with fingers or the Ball End Screwdriver provided. DO NOT fully tighten, leave 1/2" (12mm) exposed.

2. Inserte el perno en la ranura. Gírelo en el sentido de las agujas del reloj con los dedos o con el destornillador con cabeza de bola. NO lo apriete del todo, deje 1/2" (12 mm) fuera.

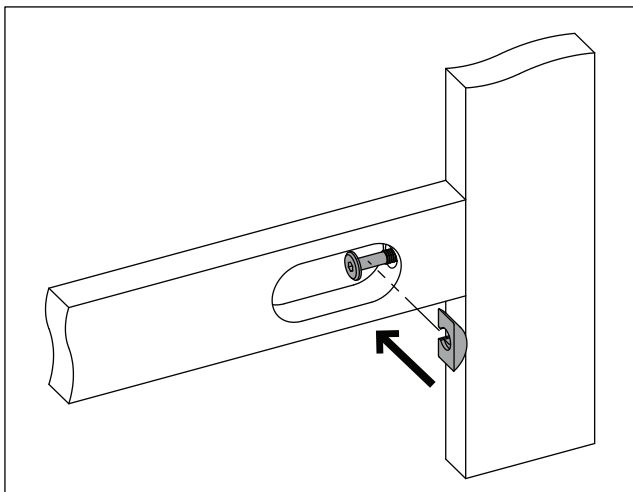
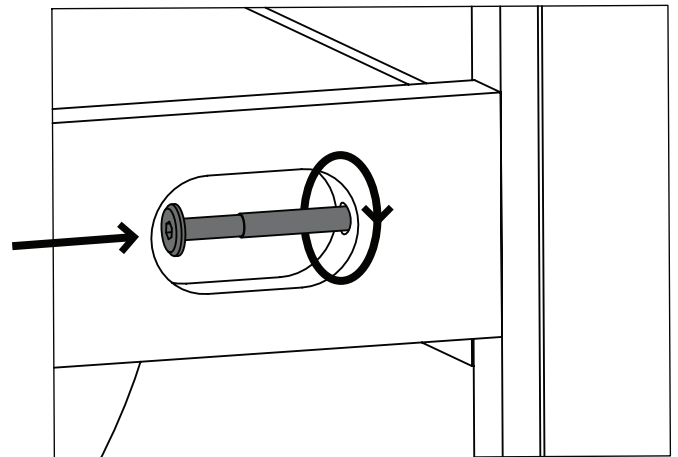

3. Slide the Crescent Washer over the exposed bolt, behind the head of the bolt.

3. Abrace la parte del Perno que quedó fuera, debajo de la cabeza del mismo, con la Arandela de media luna.

Install (1) bolt and (1) crescent washer at a time. Tighten until it looks like the picture.

Instale (1) perno y (1) Arandela de media luna al mismo tiempo. Apriételos hasta que quede como en la ilustración.

Tighten the bolt with the ball end
screwdriver.

Apriételo con el Destornillador hcon cabeza
de bola.

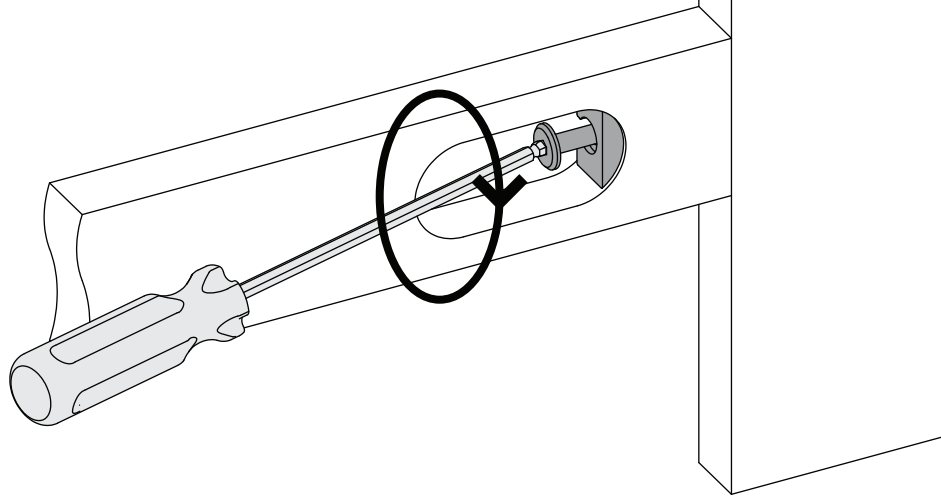

Ensure all bolts are tight with Allen wrench.

Apriételo con la llave Allen.

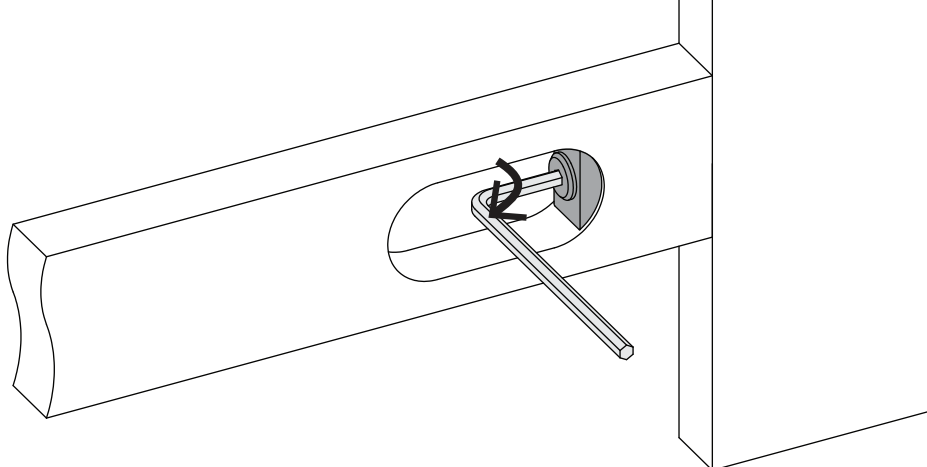

STEP 1 PASO 1

Parts and tools required to complete step

Piezas y herramientas necesarias para completar este paso

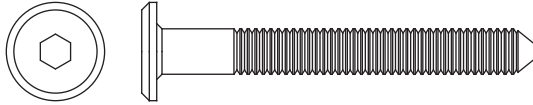

CC 50mm Bolt x6
Perno 50mm



BB Crescent Washer x6
Arandela de media luna

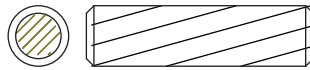

FF Φ 8x30mm Dowel x10
Pasador Φ 8x30mm

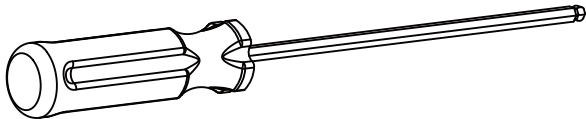

M4 Ballend Screwdriver
destornillador M4 con cabeza de bola



M4 Allen Wrench
Llave Allen M4

Attach the Top Front Rail (Part E), (2) Drawer Rails (Part H), Top Back Rail (Part F) and the Bottom Back Rail (Part D) to the Left Side (Part B) using (6) 50mm bolts (Part CC), (6) Crescent Washer (Part BB) and (10) Dowels (Part FF). Tighten the Bolts with the M4 Ballend Screwdriver and M4 Allen wrench, following the instructions on pages 12 and 13.

Fije la Barra Frontal Superior (Pieza E), (2) Barra de la gaveta (Pieza H) Barra Posterior Superior (Pieza F) y Barra trasero inferior (Pieza D) au Lado izquierdo (Pieza B) utilizando (6) Pernos 50mm (Pieza CC), (6) Arandela de media luna (Pieza BB) y (10) Pasadors (Pieza FF) utilizando el destornillador M4 con cabeza de bola y la llave Allen M4 siguiendo las instrucciones de las páginas 12 y 13.

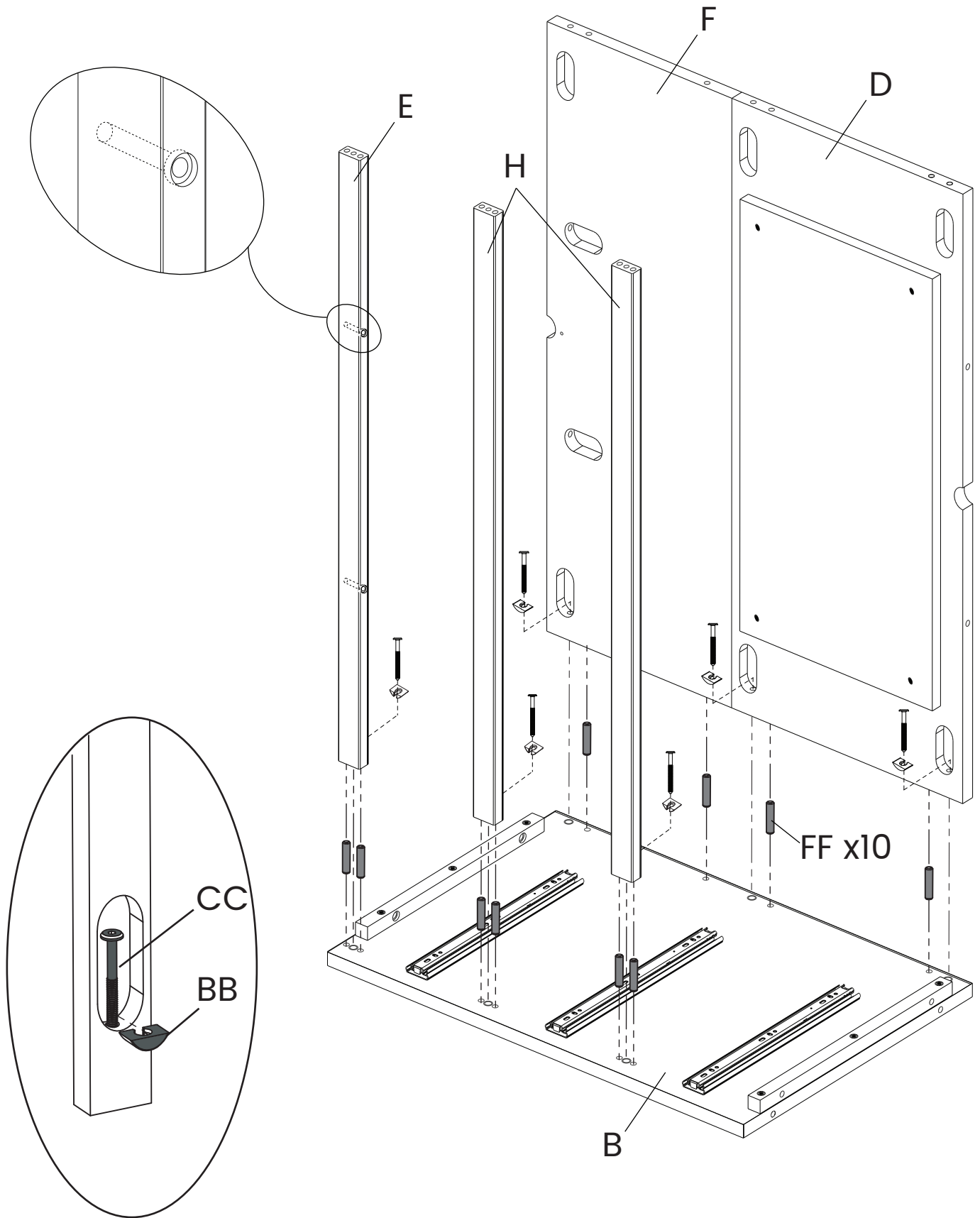

x6

STEP 2 PASO 2

Parts and tools required to complete step
Piezas y herramientas necesarias para completar este paso

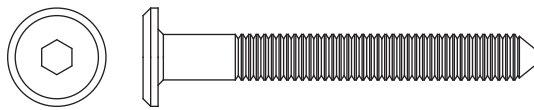

CC 50mm Bolt x6
Perno 50mm



BB Crescent Washer x6
Arandela de media luna



FF Φ 8x30mm Dowel x10
Pasador Φ 8x30mm

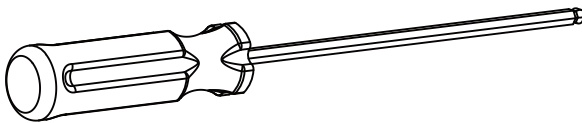

M4 Ballend Screwdriver
destornillador M4 con cabeza de bola



M4 Allen Wrench
Llave Allen M4

Attach the Right Side (Part C) using (6) 50mm bolts (Part CC), (6) Crescent Washer (Part BB) and (10) Dowels (Part FF). Tighten the Bolts with the M4 Ballend Screwdriver and M4 Allen wrench, following the instructions on pages 12 and 13.

Fije el lado derecho (Pieza C) utilizando (6) Pernos 50mm (Pieza CC), (6) Arandela de media luna (Pieza BB) y (10) Pasadors (Pieza FF) utilizando el destornillador M4 con cabeza de bola y la llave Allen M4 siguiendo las instrucciones de las páginas 12 y 13.

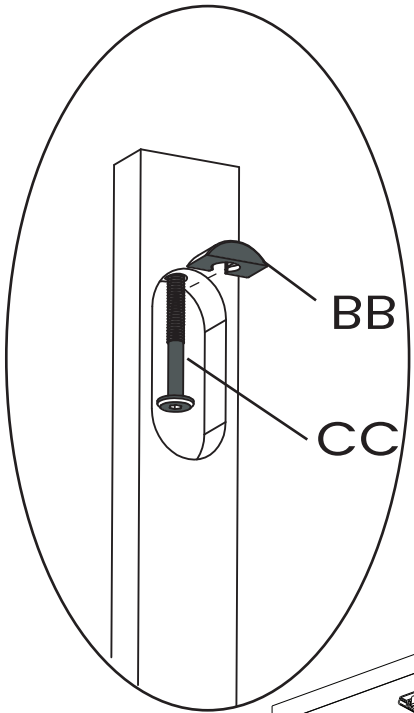

x6

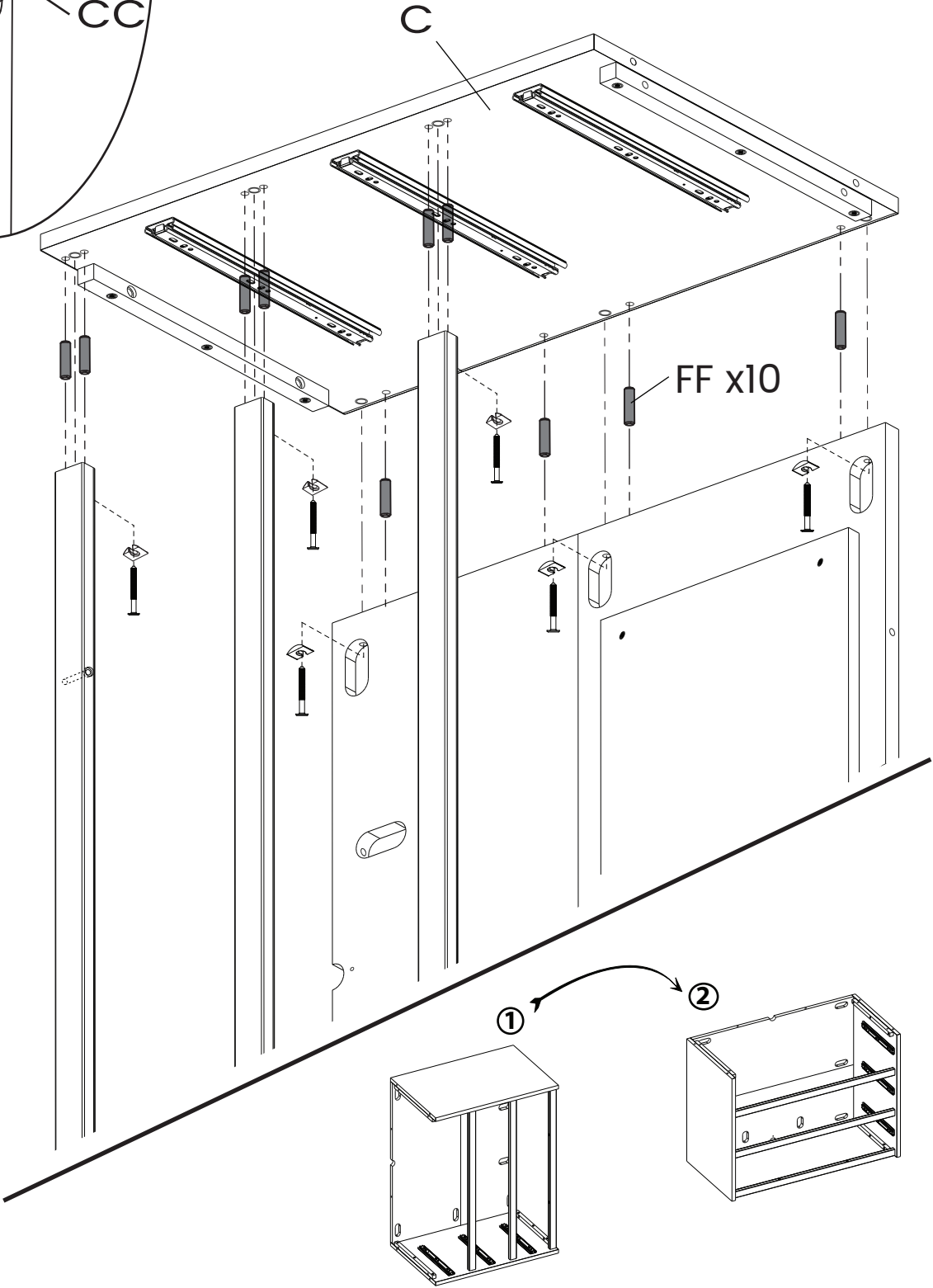

STEP 3 PASO 3

Parts and tools required to complete step

Piezas y herramientas necesarias para completar este paso

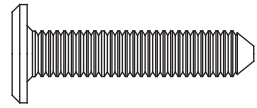

GG 30mm Bolt x4
Perno 30mm



CC 50mm Bolt x2
Perno 50mm

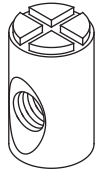

MM Barrel Nut x2
Tuercacilíndrica



FF 30mm Wood Dowel x4
Pasador de Madera 30mm

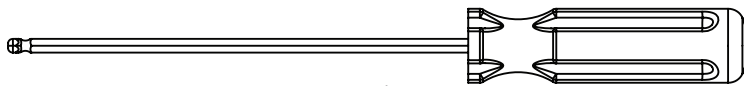

M4 Ballend Screwdriver
destornillador M4 con cabeza de bola



M4 Allen Wrench
Llave Allen M4

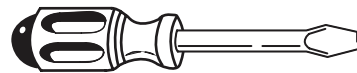

Flat Screwdriver – Not included
destornillador de cabeza plana – no incluido

Attach the Bottom Panel (Part R) using (4) Dowels (Part FF), (2) 50mm Bolts (Part CC), (2) Barrel Nuts (Part MM) and (4) 30mm bolts (Part GG). Tighten with the M4 Allen Wrench. Use the Flat Head Screwdriver to hold the Barrel Nut in the proper alignment.

Fije el Panel inferior (Pieza R) utilizando (4) Pasadores (Pieza FF), (2) pernos de 50 mm (Pieza CC), (2) Tuerca cilíndrica (Pieza MM) y (4) Pernos 30 mm (Pieza GG). Apriete todos los pernos utilizando la Llave Allen M4. Utilice el destornillador de cabeza plana para sostener la tuerca de barril en la alineación adecuada.

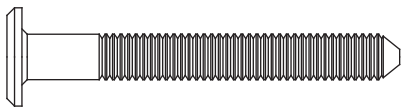

CC

50mm Bolt x2
Perno 50mm



FF

30mm Wood Dowel x4
Pasador de Madera 30mm



MM

Barrel Nut x2
Tuercacilíndrica

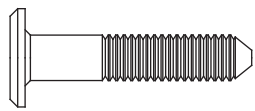
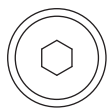
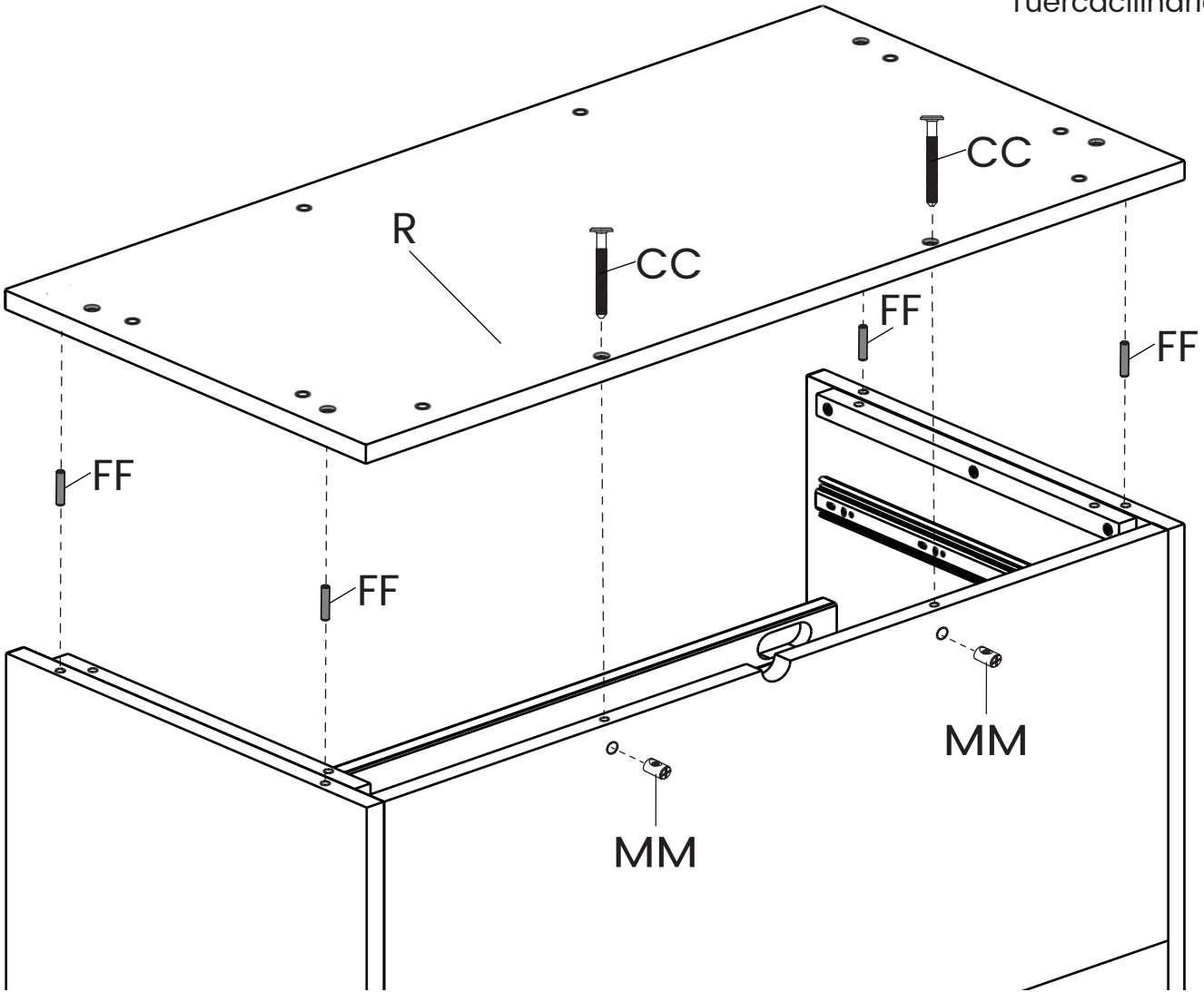

GG

30mm Bolt x4
Perno 30mm

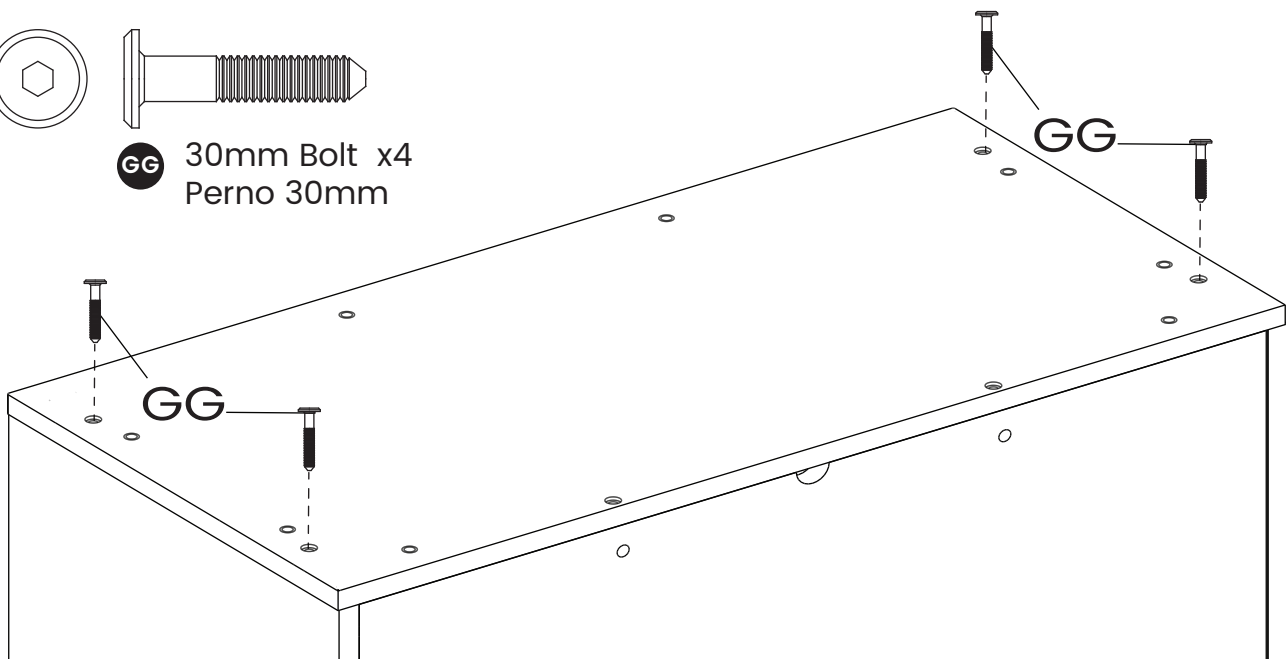

STEP 4 PASO 4

Parts and tools required to complete step

Piezas y herramientas necesarias para completar este paso

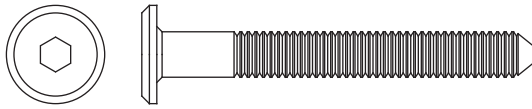

CC 50mm Bolt x2
Perno 50mm



BB Crescent Washer x2
Arandela de media luna

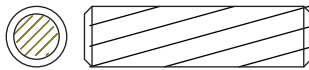

FF Φ 8x30mm Dowel x4
Pasador Φ 8x30mm

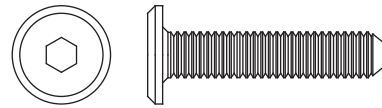

GG 30mm Bolt x2
Perno 30mm

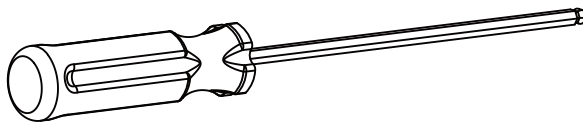

M4 Ballend Screwdriver
destornillador M4 con cabeza de bola



M4 Allen Wrench
Llave Allen M4

Attach the Base Rail (Part K) and (2) Corner Braces (Part S) to the Left Base Side (Part T) and Right Base Side (Part N) using (2) 30mm bolts (Part GG), (2) 50mm bolts (Part CC), (2) Crescent Washer (Part BB) and (4) Dowels (Part FF). Tighten the Bolts with the M4 Ballend Screwdriver and M4 Allen wrench, following the instructions on pages 12 and 13.

Fije la Barra de la Base (Pieza K) y (2) Refuerzo para la esquina (Pieza S) al Lado Izquierdo de la Base (Pieza T) y Lado Derecho de la Base (Pieza N) utilizando (2) Pernos 30 mm (Pieza GG), (2) Pernos 50mm (Pieza CC), (2) Arandela de media luna (Pieza BB) y (4) Pasadors (Pieza FF) utilizando el destornillador M4 con cabeza de bola y la llave Allen M4 siguiendo las instrucciones de las páginas 12 y 13.

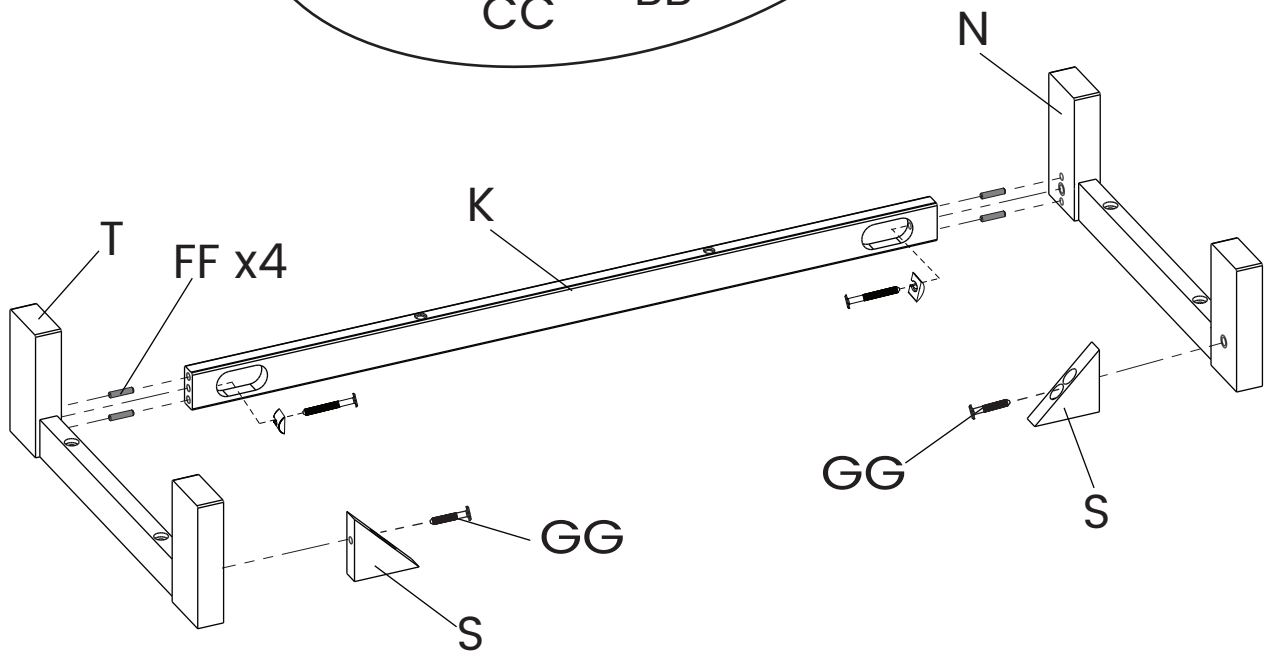
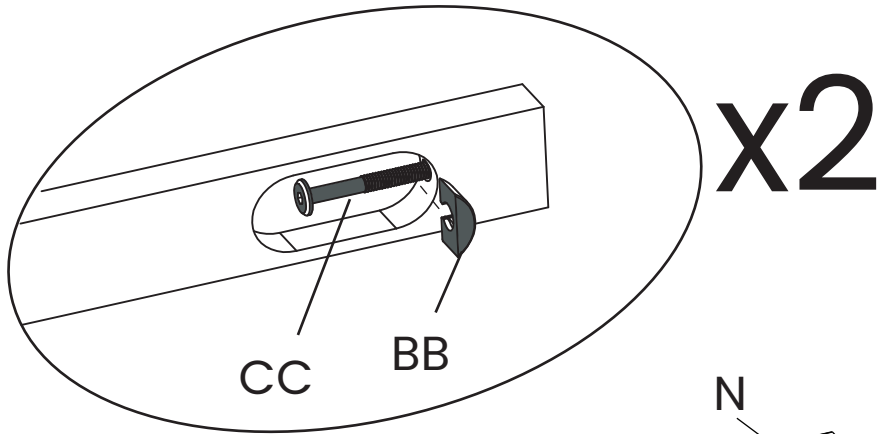

STEP 5 PASO 5

Parts and tools required to complete step

Piezas y herramientas necesarias para completar este paso

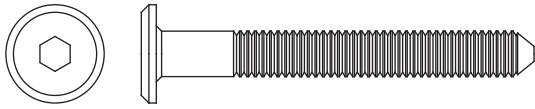

CC 50mm Bolt x6
Perno 50mm

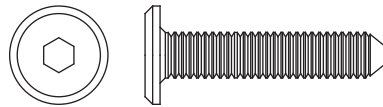

GG 30mm Bolt x2
Perno 30mm

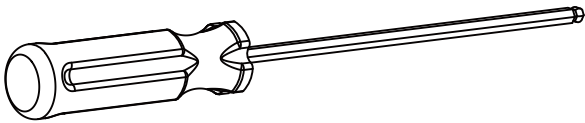

M4 Ballend Screwdriver
destornillador M4 con cabeza de bola



M4 Allen Wrench
Llave Allen M4

Attach the Assembly from Step 4 to the assembly from step 3 using (2) 30mm bolts (Part GG) and (6) 50mm bolts (Part CC). Tighten the Bolts with the M4 Ballend Screwdriver and M4 Allen wrench. Use the Flat Head Screwdriver to hold the Barrel Nut in the proper alignment.

Fije el ensamblaje del paso 4 al conjunto de piezas del paso 3 utilizando (2) Pernos 30 mm (Pieza GG), (6) Pernos 50mm (Pieza CC). Apriete todos los pernos utilizando el destornillador M4 con cabeza de bola y la llave Allen M4. Utilice el destornillador de cabeza plana para sostener la tuerca de barril en la alineación adecuada.

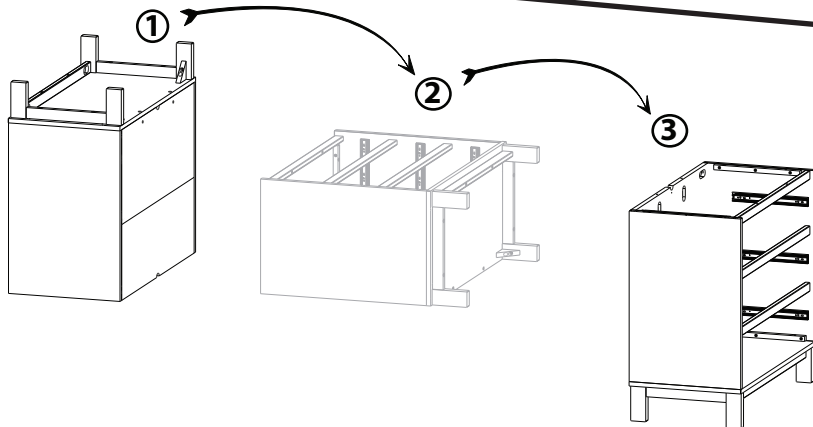
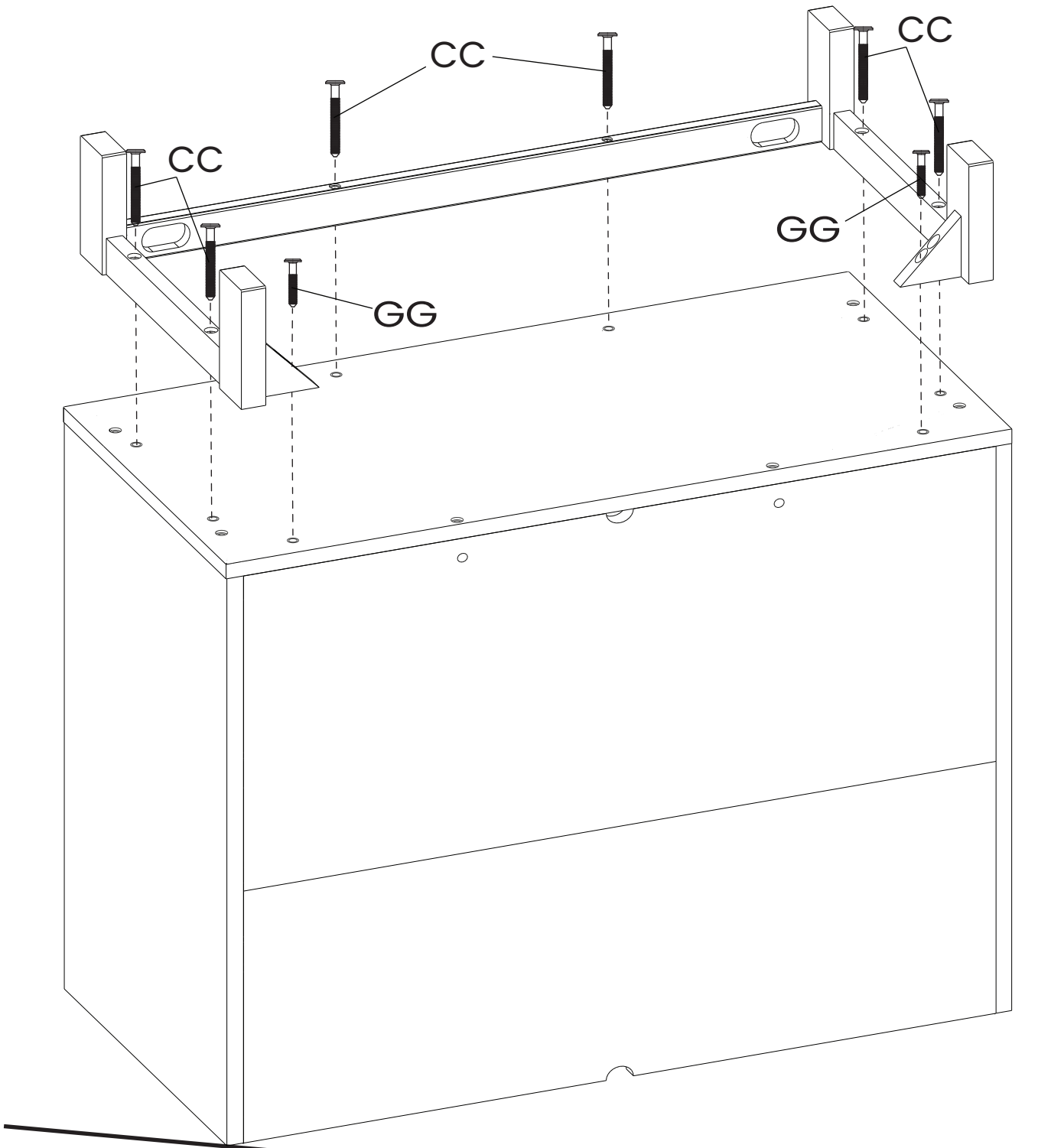

STEP 6 PASO 6

Parts and tools required to complete step
Piezas y herramientas necesarias para completar este paso

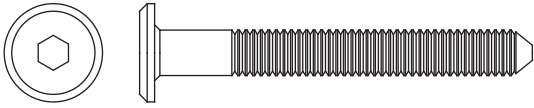

CC 50mm Bolt x4
Perno 50mm



BB Crescent Washer x2
Arandela de media luna



FF 30mm Wood Dowel x4
Pasador de Madera 30mm

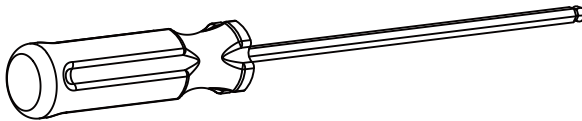

M4 Allen Wrench
Llave Allen M4

Attach the Top Panel (Part A) to the assembly from Step 5 using (4) 50mm bolts (Part CC), (2) Crescent Washer (Part BB) and (4) Dowels (Part FF). Tighten the Bolts with the M4 Ballend Screwdriver and M4 Allen wrench.

Fije el Panel Superior (Pieza A) al ensamblaje del Paso 5 utilizando (4) Pernos 50mm (Pieza CC), (2) Arandela de media luna (Pieza BB) y (4) Pasadors (Pieza FF) utilizando el destornillador M4 con cabeza de bola y la llave Allen M4.

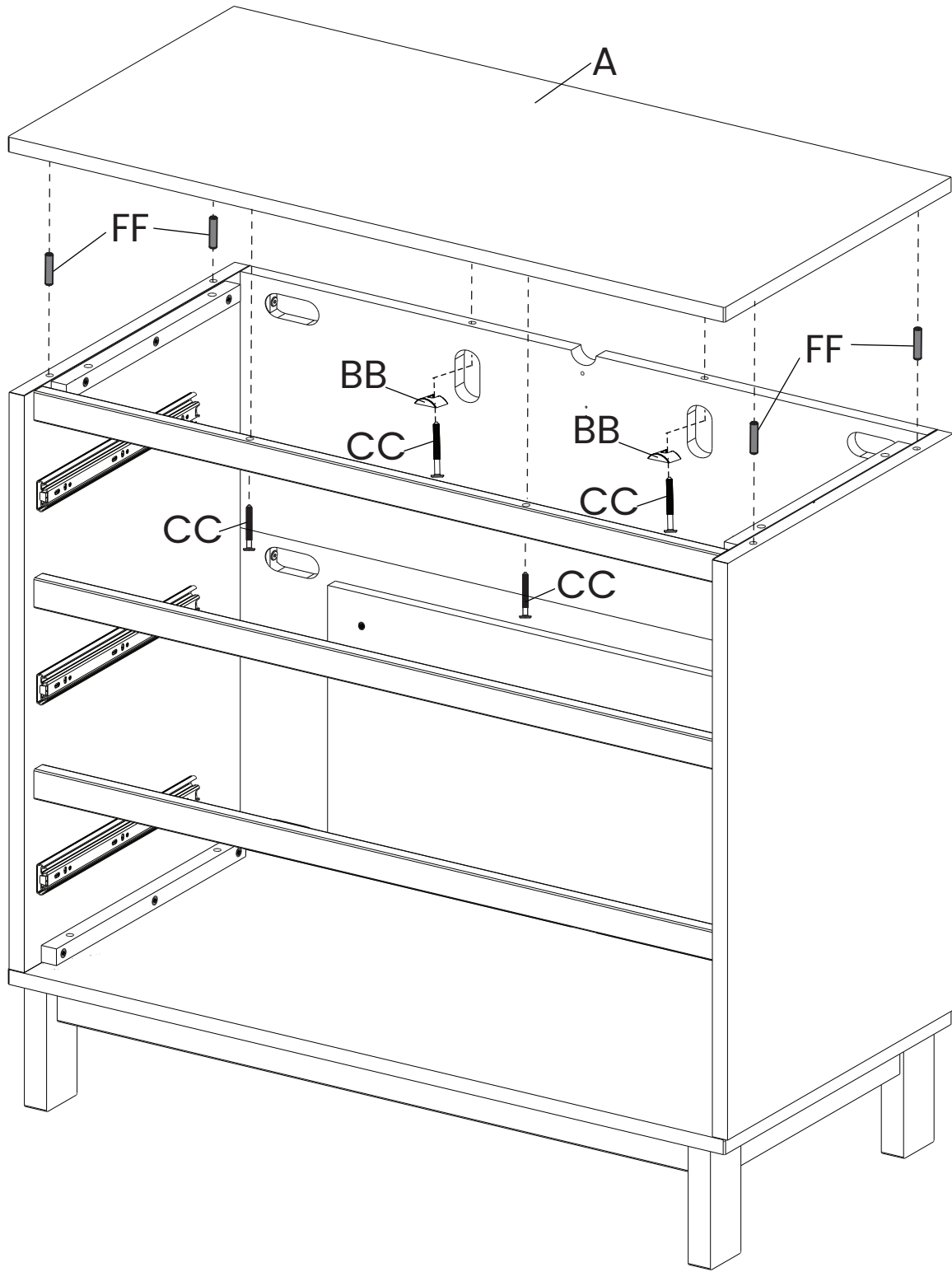

STEP 7 PASO 7

Parts and tools required to complete step

Piezas y herramientas necesarias para completar este paso

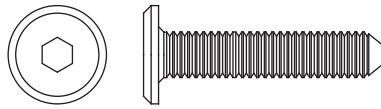

GG 30mm Bolt x4
Perno 30mm

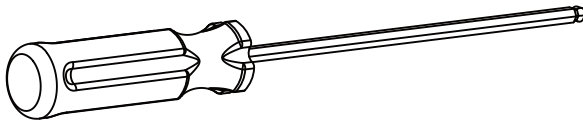

M4 Allen Wrench
Llave Allen M4

Attach the Top Panel (Part A) using (4) 30mm bolts (Part GG). Tighten the Bolts with the M4 Ballend Screwdriver and M4 Allen wrench.

Fije el Panel Superior (Pieza A) utilizando (4) Pernos 30 mm (Pieza GG) utilizando el destornillador M4 con cabeza de bola y la llave Allen M4.

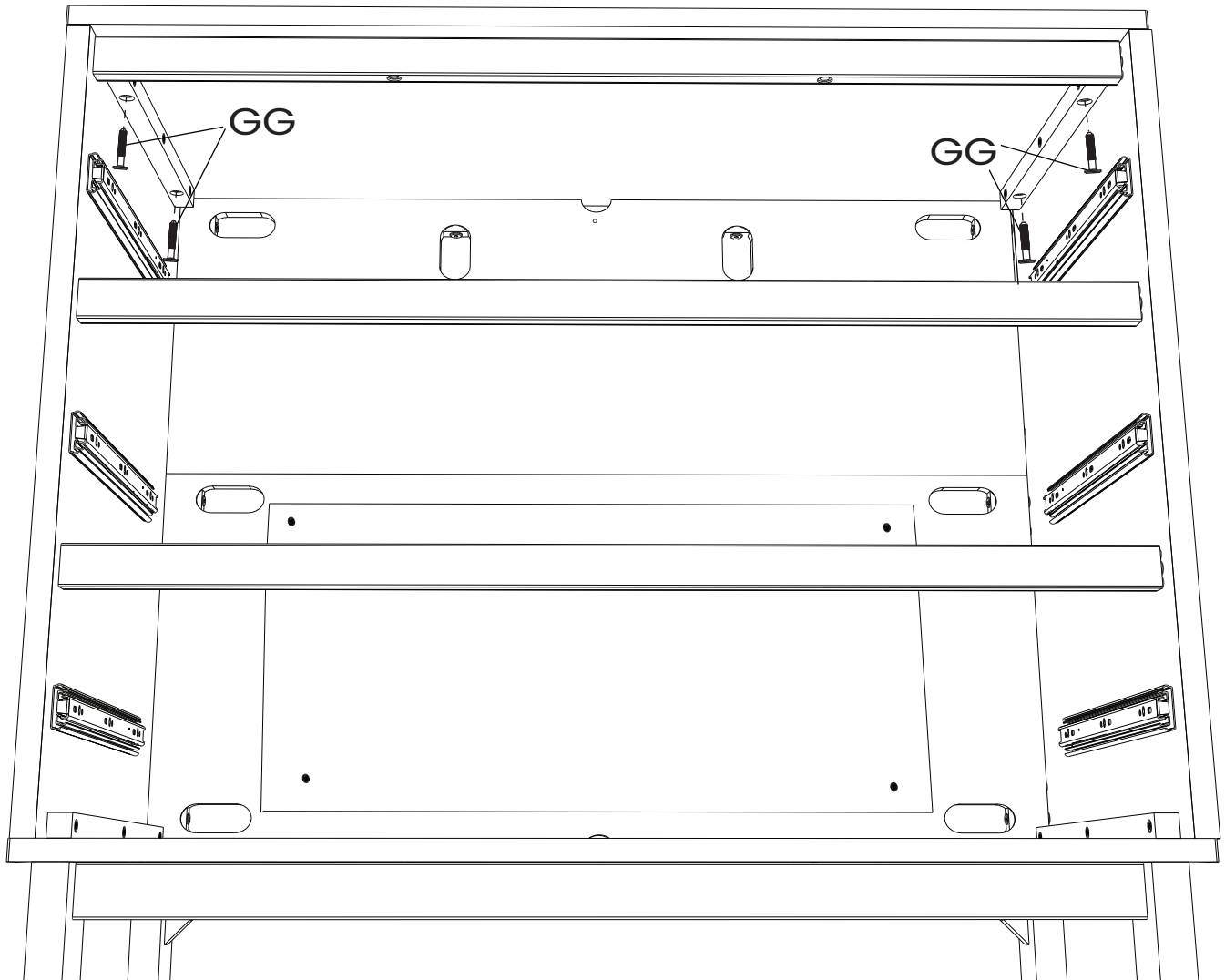

STEP 7
PASO 7

Tipover Restraint
Protección contra volcamiento

▲ WARNING

Use of tip-over restraints may only reduce, but not eliminate, the risk of tip-over.

Do not attempt to Screw into the wallboard only. You must Screw into a wood wall stud or other wood structure such as securely attached baseboard. If your wall is not wood stud construction, see your local hardware store or home center for a wall anchor system that will hold a pull force of 50 LBS in your wall type. If you are unsure of how to locate the wood stud, or of what type of wall you have, contact a professional contractor.

▲ ADVERTENCIA

El uso de herramientas de contención de vuelcos tan solo puede reducir, pero no eliminar, el riesgo de vuelco.

No intente atornillar a paredes hechas únicamente de paneles. Debe atornillar en un pilar u otra estructura de madera similar, como un zócalo fijado de manera segura. Si su pared no tiene vigas de Madera, visite su ferretería o tienda del ramo más cercana para conseguir un sistema de anclaje que soporte una fuerza de tiraje de hasta 50 LBS (22,7 Kgs) para su tipo de muro. Si no está seguro sobre cómo encontrar la viga de madera o tiene dudas sobre el tipo de muro, contacte a un contratista profesional.

- 1) Choose BOTTOM or TOP attachment.
- 2) Locate the through holes in the back of the dresser.
- 3) Align the hole to be used with the wood wall stud (For Open Bottom Installation, use wood wall stud closest to center)

- 1) Seleccione el aditamento SUPERIOR o INFERIOR.
- 2) Ubique los orificios pasantes en la parte posterior del mueble.
- 3) Alinee el orificio que utilizará con el pilar de la pared (para una instalación con fondo abierto, utilice el pilar de madera más cercano al centro)

4) Make a pencil mark on the wall using the wood rail as a guide, pencil mark must be over wood wall stud. Then move the case away from the wall.

4) Utilizando un lápiz, haga una marca en la pared utilizando el barra de madera como guía; la marca debe estar sobre el pilar de madera. Luego, aleje la carcasa de la pared.

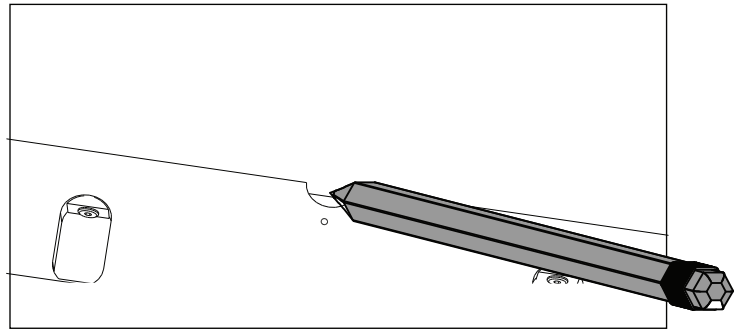

5) Drill $\varnothing 1/8$ " hole at Pencil Mark, in wood wall stud

5) Perfore un orificio de $\varnothing 1/8$ " en la marca del lápiz, sobre el pilar de madera

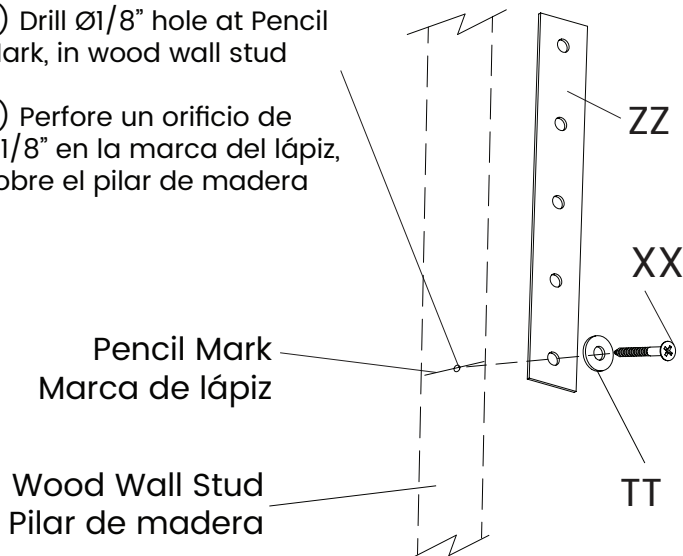

6) Attach the Tip-over restraint strap (ZZ) to the wall using (1) Long Screw (XX) and (1) washer (TT) as shown. The Screw MUST be installed into a wood wall stud (See WARNINGS for additional information).

6) Fije la correa de retención contra volcamiento (ZZ) a la pared utilizando (1) tornillo largo (XX) y (1) arandela (TT), como se indica. El tornillo DEBE instalarse en un pilar de madera (para obtener más información consulte las ADVERTENCIAS).

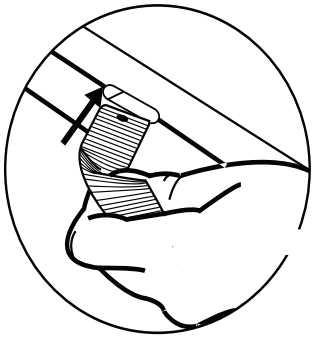

NOTE: Be sure to attach any accessory items to case before completing this step.

7) Feed the Tipover Restraint through the hole as you place the dresser in it's final position.

NOTA: Asegúrese de fijar todos los accesorios a la carcasa antes de completar este paso.

7) Pase el elemento de retención a través del orificio, a medida que posiciona el mueble en su posición final.

8) Pull the Tip-over restraint through the hole and fasten it securely to the case using (1) 15mm Screw (YY) and (1) washer (TT).

8) Pase el elemento de retención a través del orificio y fíjelo con seguridad a la carcasa utilizando (1) tornillo de 15 mm (YY) y (1) arandela (TT).

Attach to Top
Fijar a la parte superior

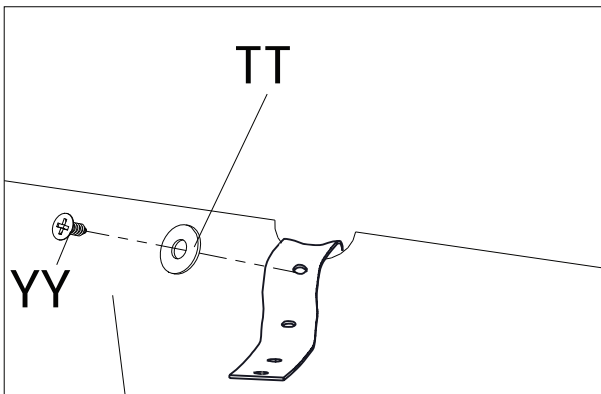

Top Back Rail
Barra Trasero Superior

Attach to Bottom
Fijar al fondo

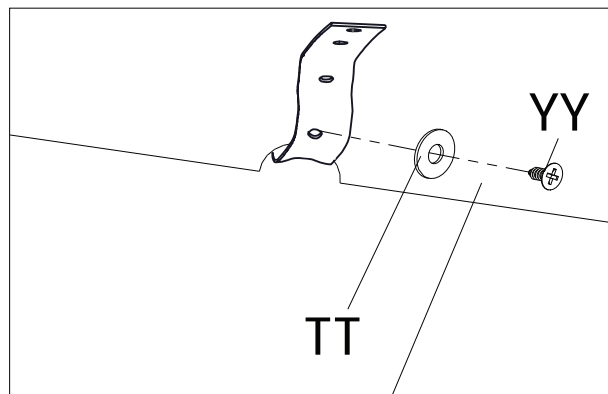

Bottom Back Rail
Barra Trasero Inferior

9) Pull case AWAY from wall until Restraint is SNUG.
9) Jale la carcasa ALEJÁNDOLA de la pared hasta que la retención esté TENSA.

10) Ensure restraint is not loose.
10) Asegúrese de que la retención no esté suelta.

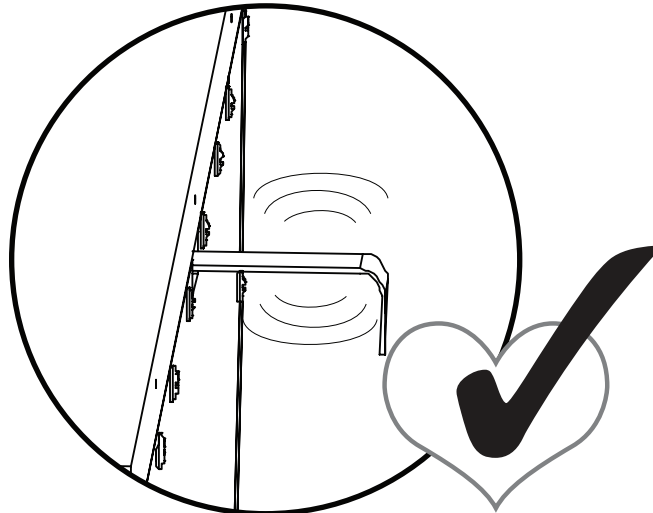
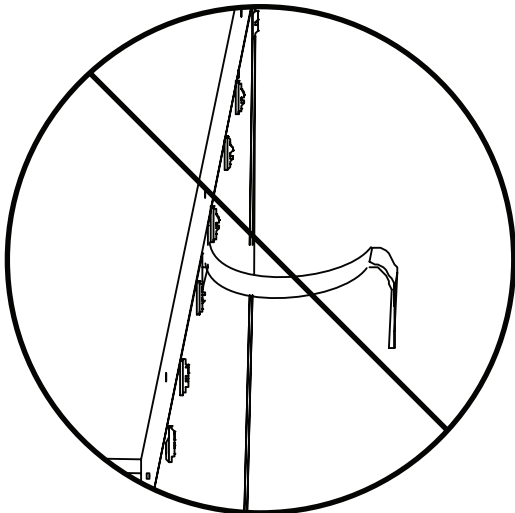

STEP 8 PASO 8

Parts and tools required to complete step

Piezas y herramientas necesarias para completar este paso

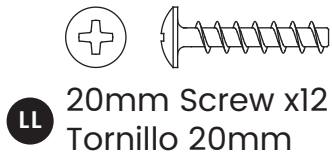

Phillips Screwdriver – Not included
Destornillador Phillips – no incluido

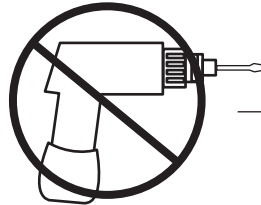

No drills necessary.
Do not use power screwdriver.

No hace falta taladrar.
No utilice destornilladores eléctricos

Slide Drawer Bottom (Part G) into the grooves. Attach (2) Drawer Sides (Part P) to the Drawer Front (Part L) with (4) 20mm Screws (Part LL).
Note: Grooves in Bottom must align. Tighten With Phillips Screwdriver. Repeat this step until 3 drawers are complete.

Deslice la Fondo de la gaveta (Pieza G) hacia las ranuras. Fije (2) Lados de la Gaveta (Pieza P) a la parte frontal de la gaveta (Pieza L) utilizando (4) tornillos 20mm (Pieza LL). Nota: Las ranuras al inferior deben alinearse. Apriete utilizando un destornillador Phillips. Repita este paso hasta haber completado las 3 gavetas .

DELTA♥CHILDREN

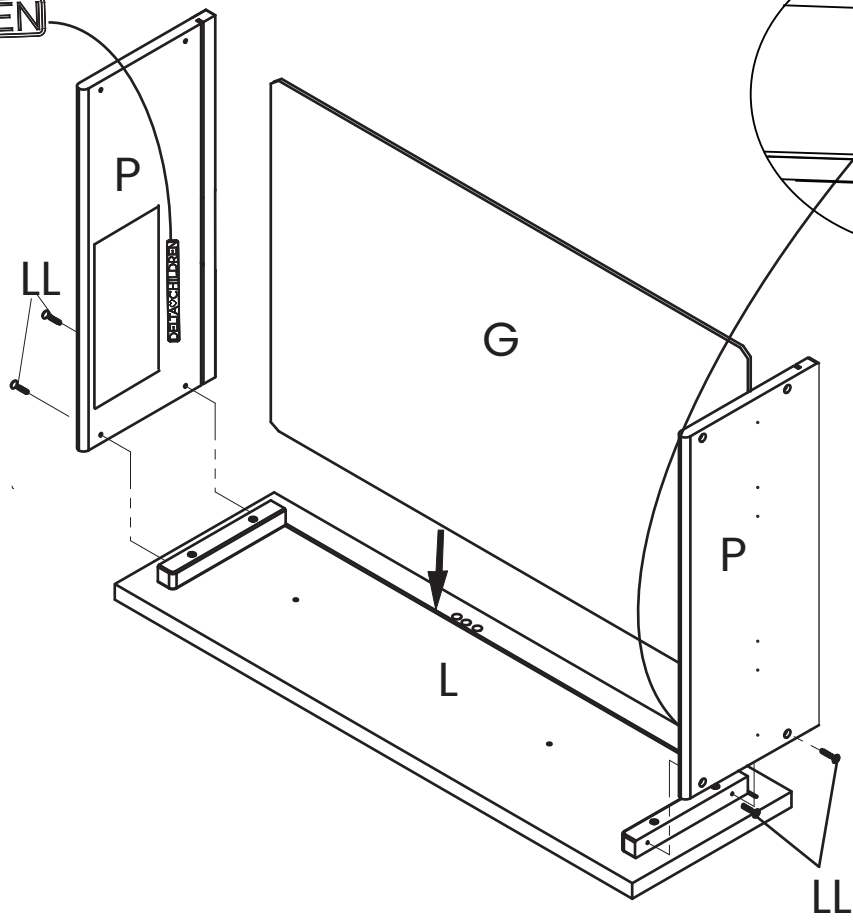

x1

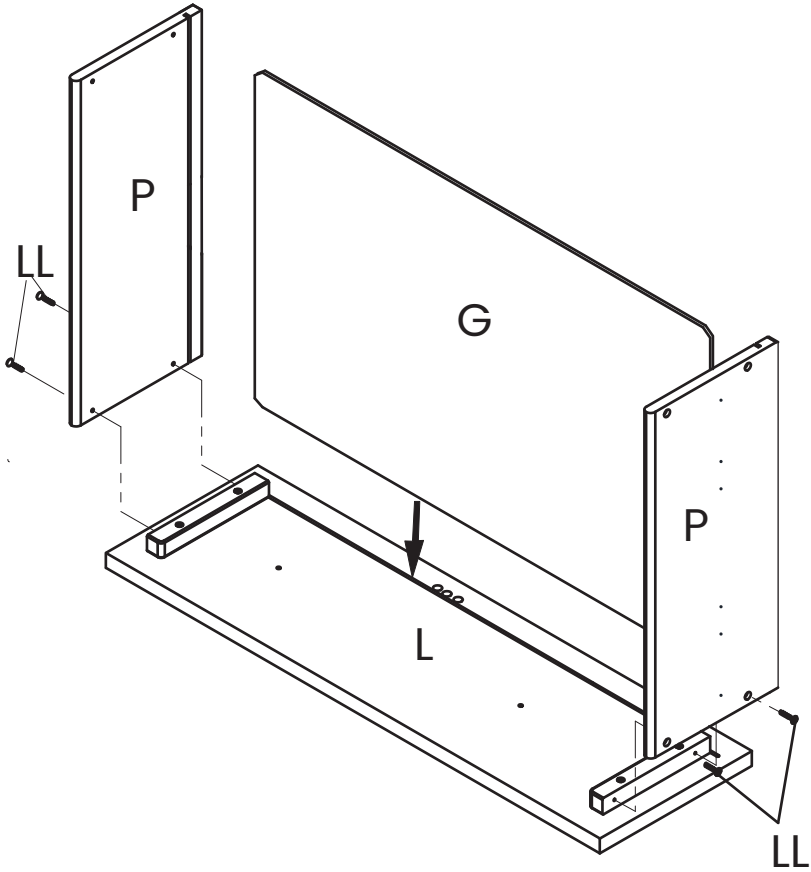

x2

STEP 9 PASO 9

Parts and tools required to complete step
Piezas y herramientas necesarias para completar este paso

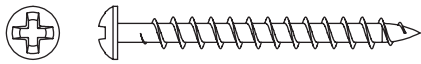

NN

40mm Screw x15
Tornillo 40mm

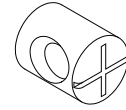

KK

Plastic Barrel Nut x15
Tuercacilíndricaplástica



Phillips Screwdriver – Not included
Destornillidor Phillips – no incluido

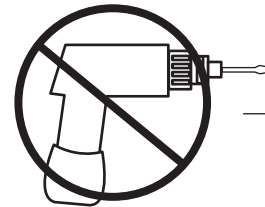

No drills necessary.
Do not use power screwdriver.

No hace falta taladrar.
No utilice destornilladores eléctricos

Install the Drawer Support (Part W) and the Drawer Back (Part M), using (5) 40mm Screws (Part NN) and (5) Plastic Barrel Nuts (Part KK). Note: Grooves In Bottom Must Align. Tighten With Phillips Screwdriver. Repeat this step until 3 drawers are complete.

Instale el soporte de gaveta (Pieza W) y Trasera de la gaveta (Pieza M) utilizando (5) tornillos de 40 mm (Pieza NN) y (5) tuercas cilíndricas plásticas (Pieza KK). Nota: Las ranuras al inferior deben alinearse. Apriete utilizando un destornillador Phillips. Repita este paso hasta haber completado las 3 gavetas.

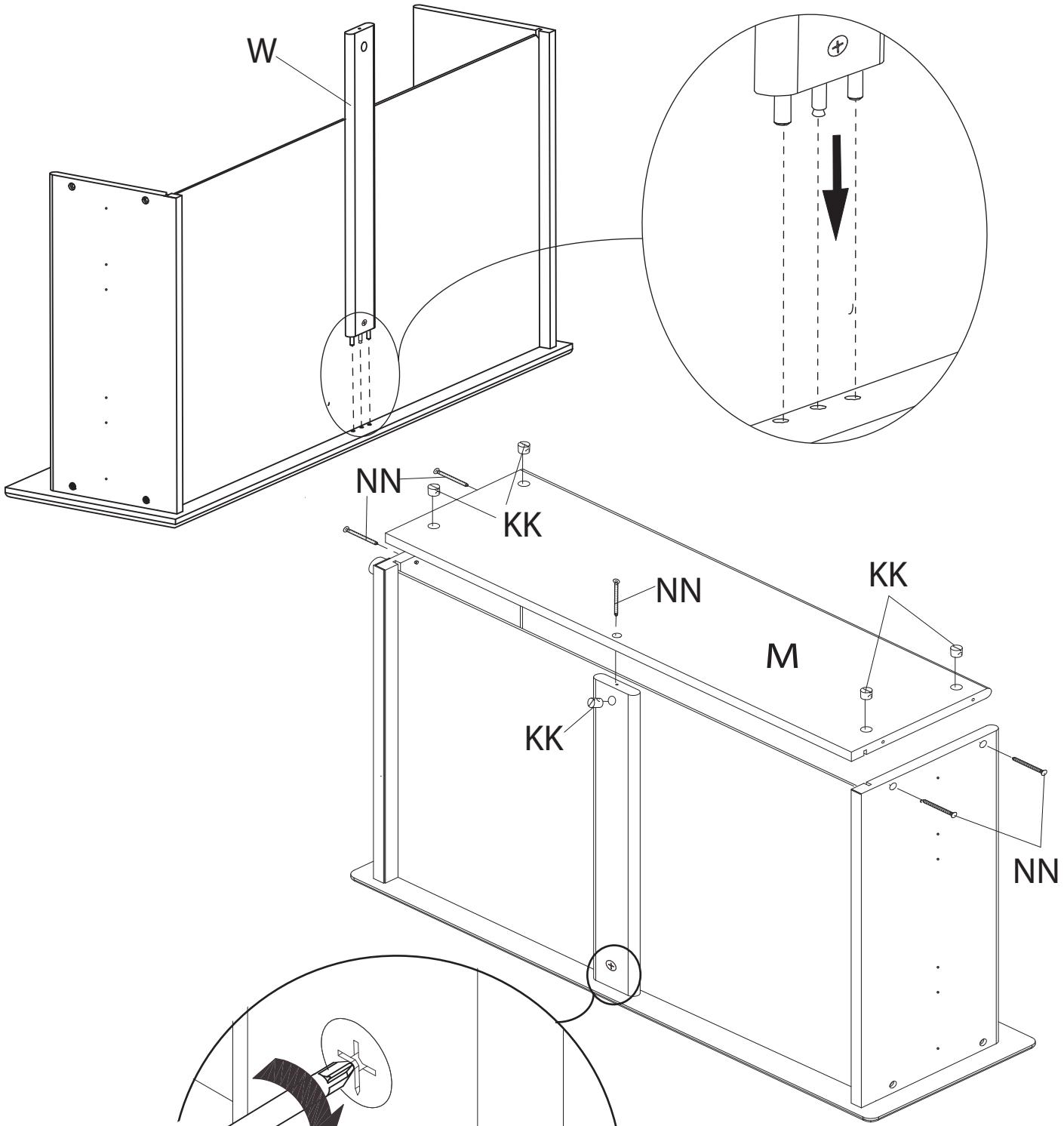

x3

STEP 10
PASO 10

Parts and tools required to complete step
Piezas y herramientas necesarias para completar este paso

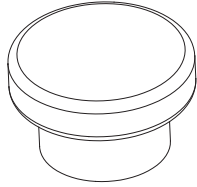

PP1 Knob x6
Perilla

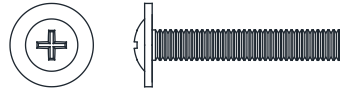

PP2 Knob Screw x6
Tornillo para Perilla

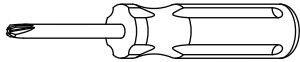

Phillips Screwdriver – Not included
Destornillidor Phillips – no incluido

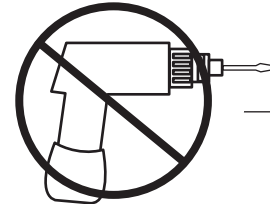

No drills necessary.
Do not use power screwdriver.

No hace falta taladrar.
No utilice destornilladores eléctricos

Attach (2) Knobs (Part PP1) to Drawer Assembly using (2) Knob Screws (Part PP2). Repeat this step until 3 drawers are complete.

Fije la (2) perillas (Pieza PP1) al ensamblaje de la gaveta utilizando (2) tornillos para Perilla (Pieza PP2). Repita este paso hasta haber completado las 3 gavetas.

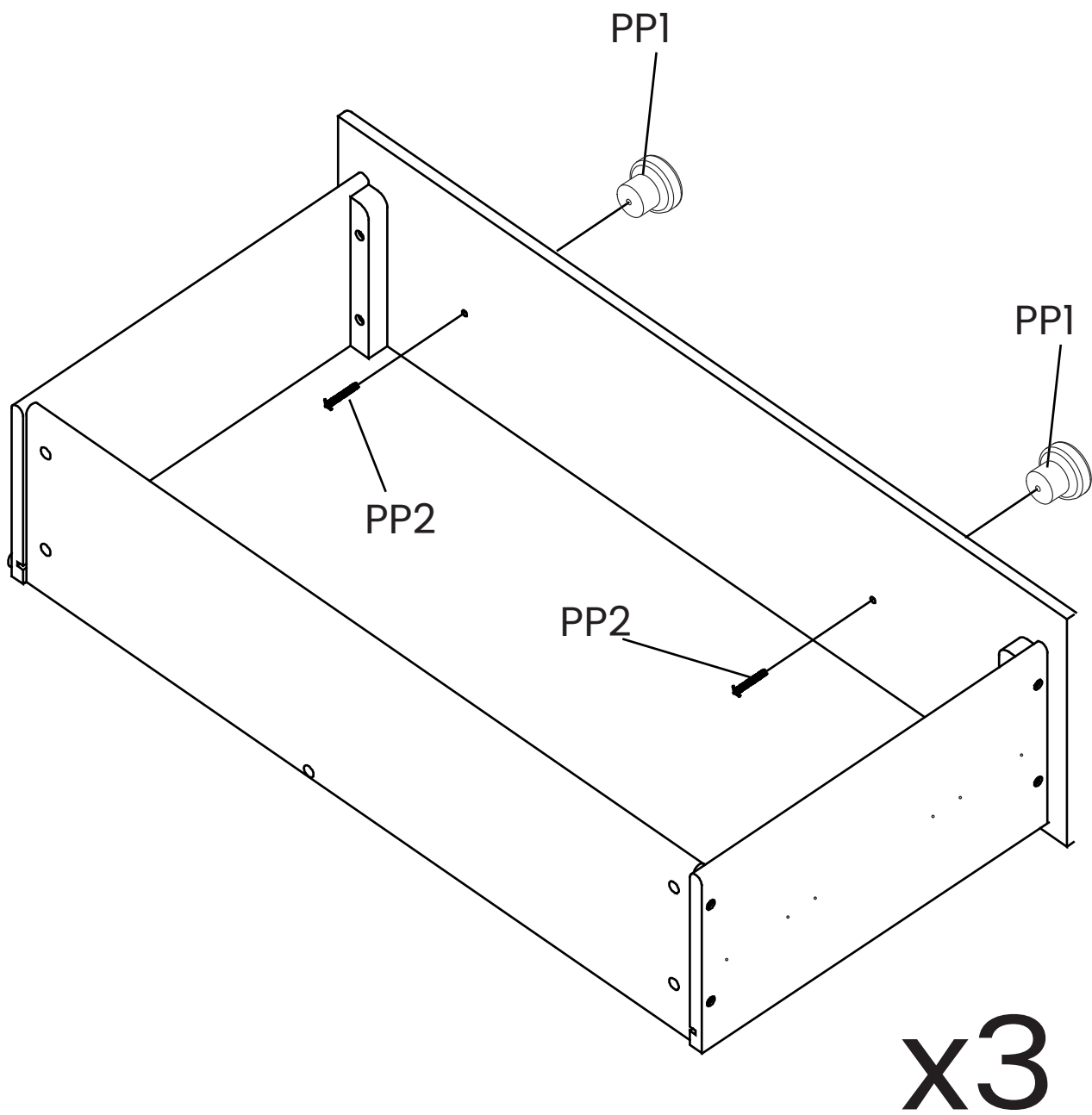

STEP 11
PASO 11

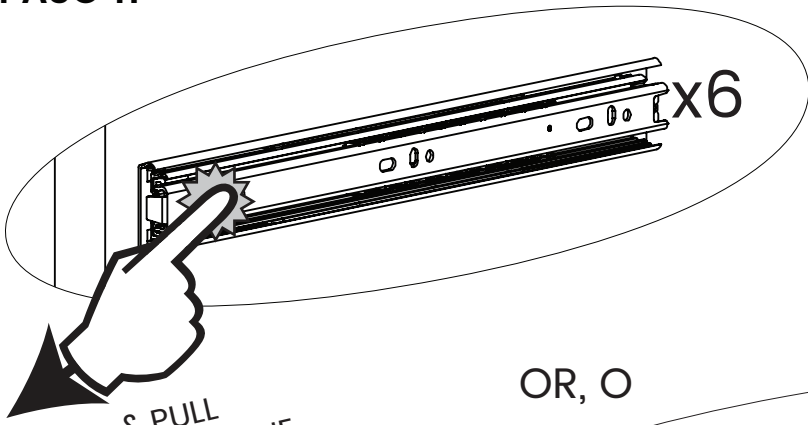

Press & PULL
Empujar & SAQUE

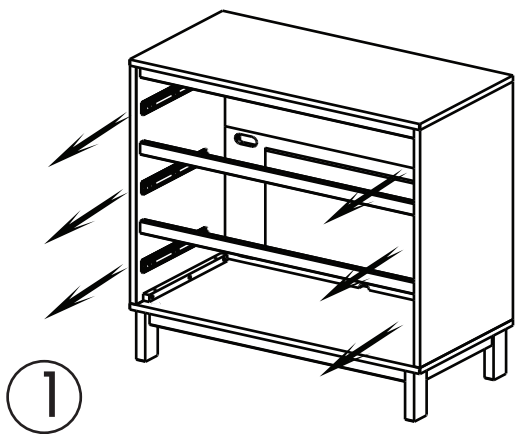

OR, O

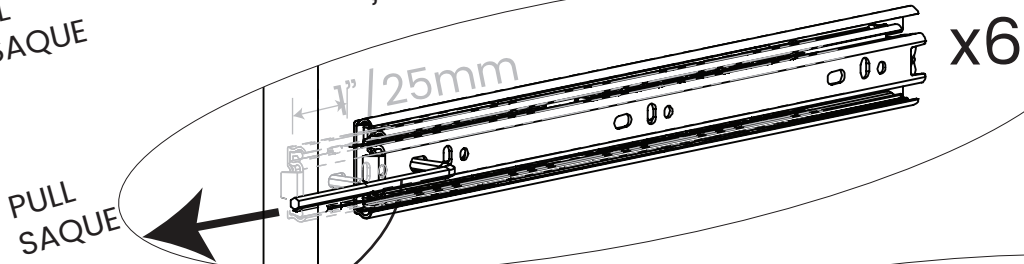

Allen Wrench
Llave Allen

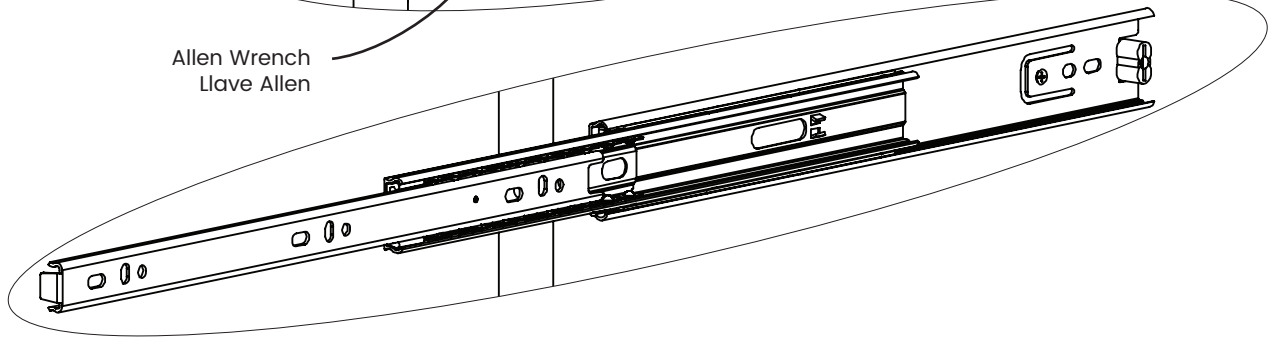

Left/Izquierdo

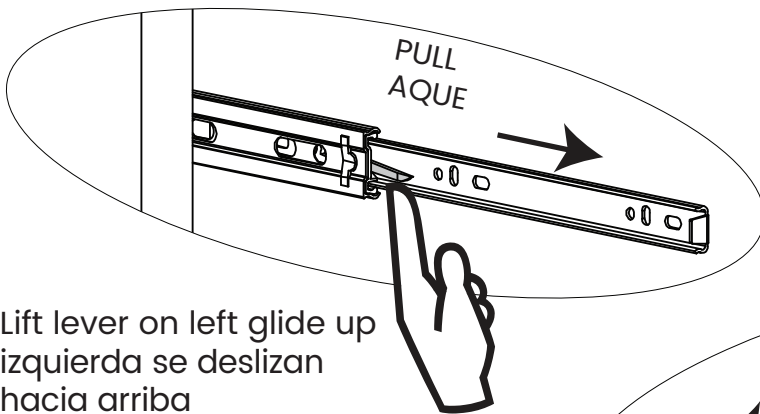

Lift lever on left glide up
izquierda se deslizan
hacia arriba

Press lever on right glide down
Empujar la palanca a la dere-
cha se deslizan por

2

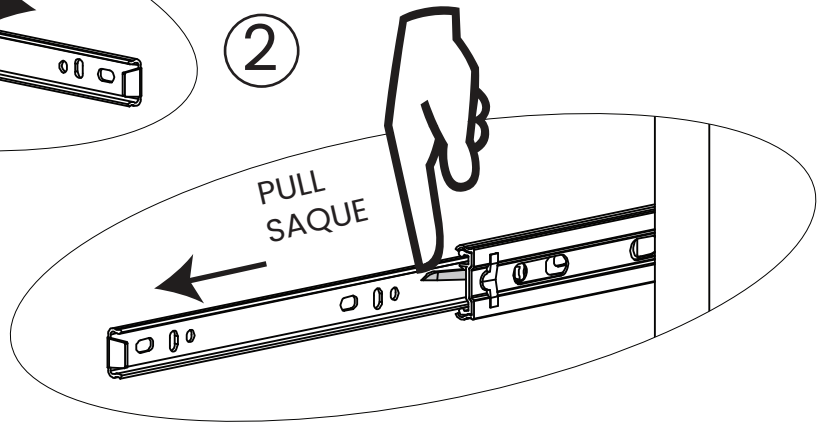

Right/Derecho

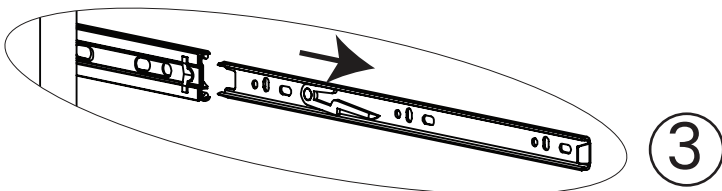

The silver portion of the glide must be pulled to the front of the glide when assembling the drawer into the case.

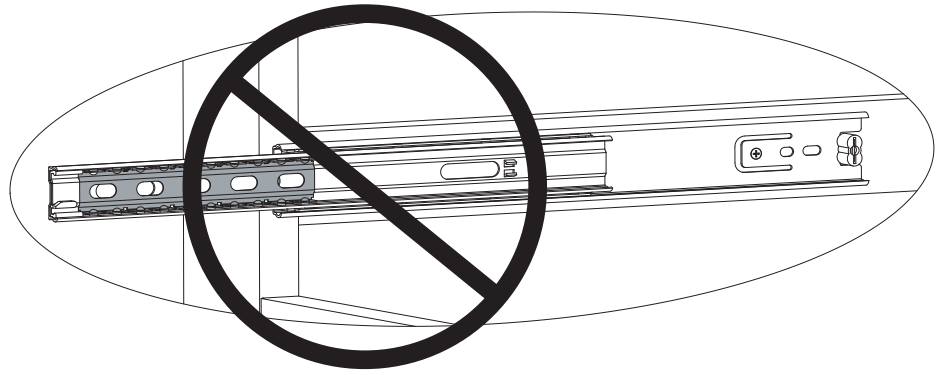

La parte plateada de la guía de la gaveta debe estar al frente de la guía cuando se está armando la cómoda.

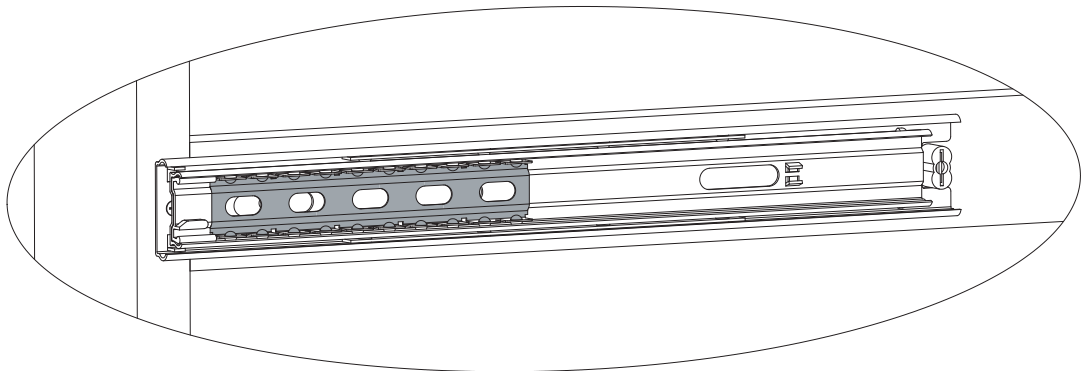
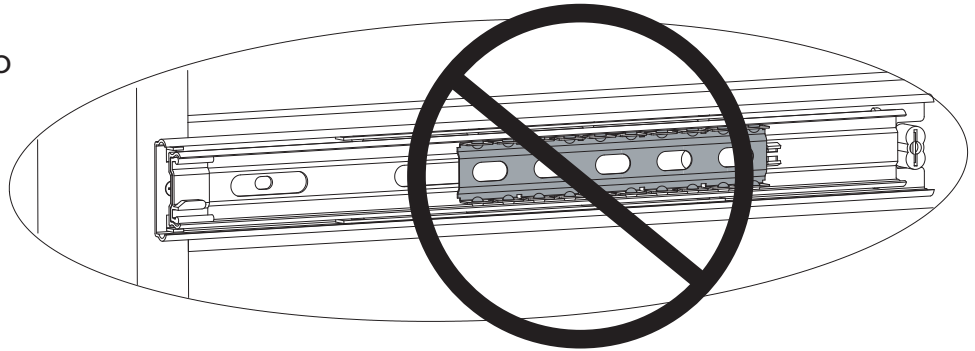

To insert drawer align male runner on drawer to female runner on case and push all the way in.

Para insertar la gaveta alinear runner mujer en la gaveta para de hombre runner case y empuje hasta el fondo.

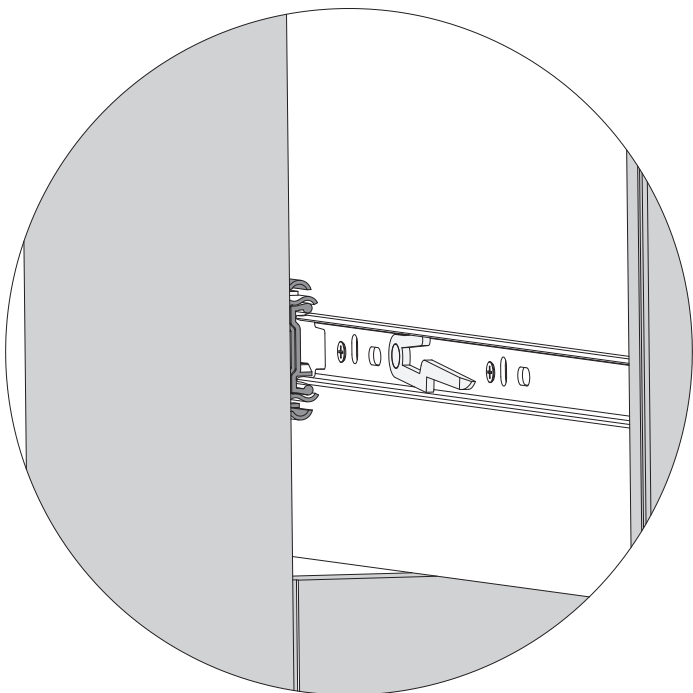

STEP 12 PASO 12

Parts and tools required to complete step
Piezas y herramientas necesarias para completar este paso

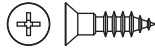

EE

12mm Screw x18
Tornillo 12mm

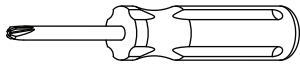

Phillips Screwdriver – Not included
Destornillidor Phillips – no incluido

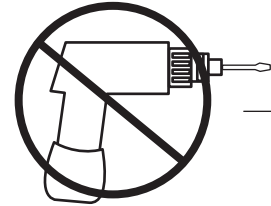

No drills necessary.
Do not use power screwdriver.

No hace falta taladrar.
No utilice destornilladores eléctricos

Attach (2) Drawer Guide outer pieces to each assembled drawer. There are pre-drilled holes in each drawer side.

- Place the end of the Drawer Guide with the tab against the Drawer front, then align the holes in the Guide to the holes in the Side, tab should remain very close to the Drawer Front.
- Attach the Drawer Guide with (3) screws (Part EE). Install the screws from the back to the front (1st, 2nd, 3rd in the illustration). Tighten with a Phillips Screwdriver.
- repeat with the other Drawer Side.
- Repeat until all (3) Drawers are complete.

Fije (2) piezas externas de guía de gaveta en cada gaveta ensamblada. Hay agujeros pre taladrados en cada costado de la gaveta.

- Coloque el extremo de la guía de gaveta, con la lengüeta contra la parte frontal de la gaveta, luego alinee la guía con los agujeros del costado; la lengüeta debe quedar muy cerca de la parte frontal de la gaveta.
- Fije la guía de gaveta con (3) tornillos (Pieza EE). Instale los tornillos desde la parte posterior hacia el frente (1st, 2nd, 3rd en la ilustración). Apriete con un destornillador Philips.
- Repita con el otro costado de la gaveta.
- Repita hasta completar las (3) gavetas

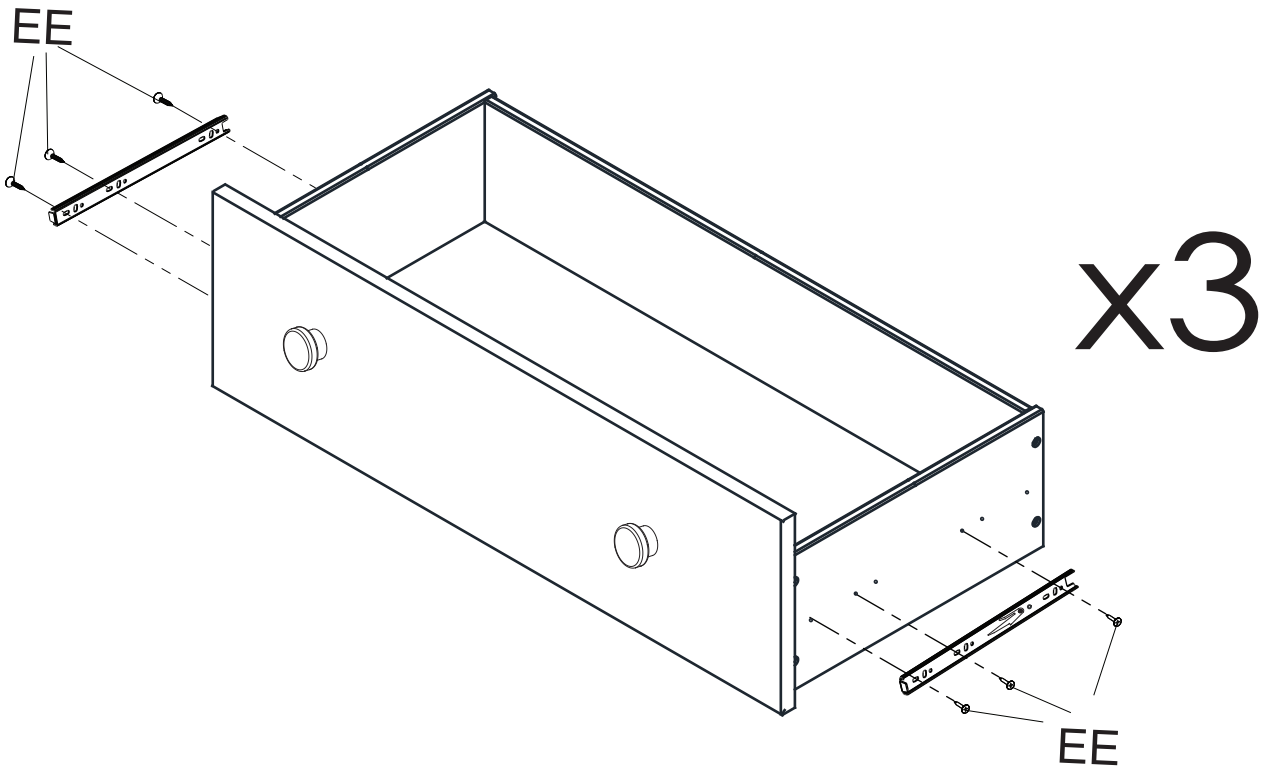
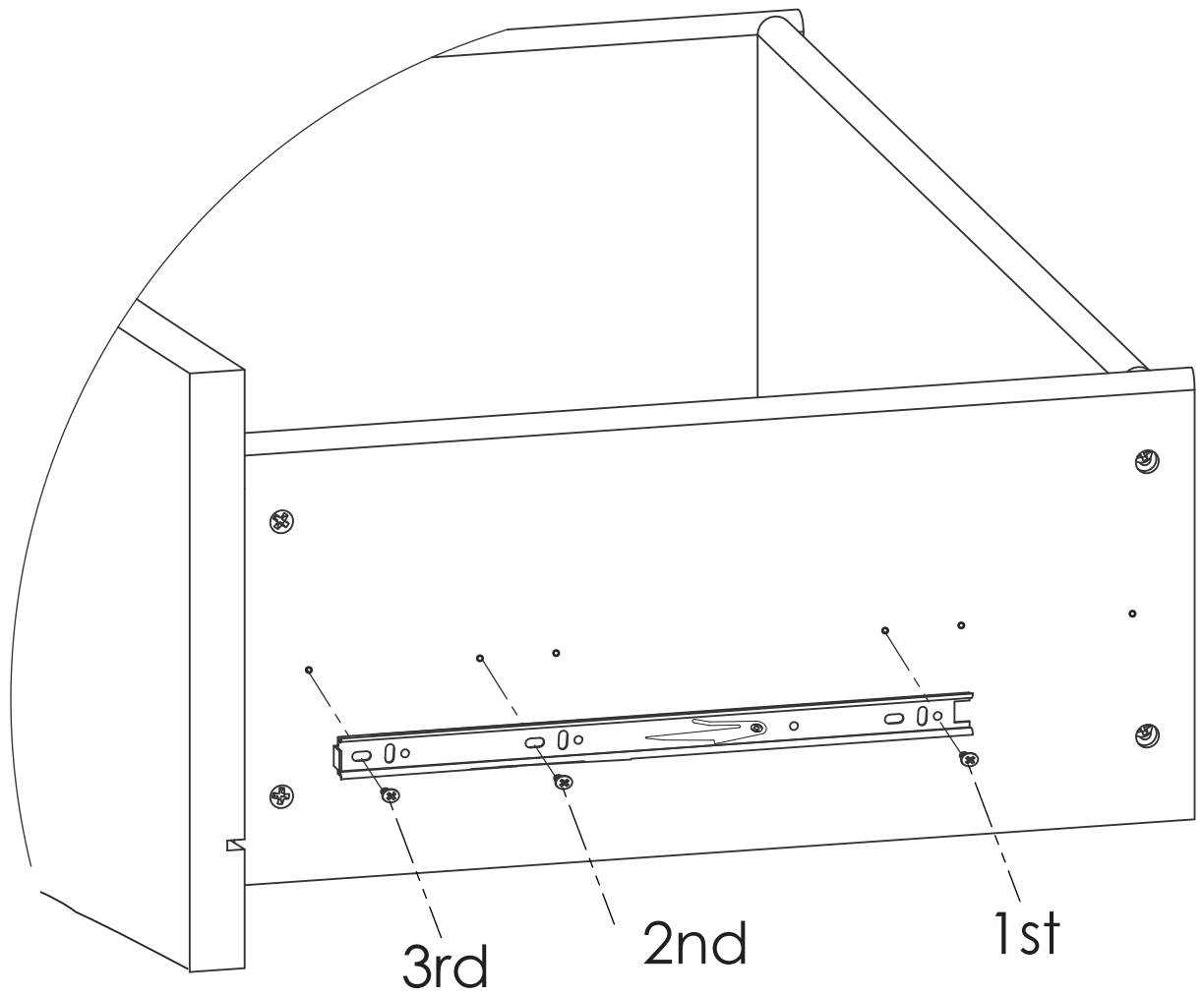

STEP 13

PASO 13

Install the drawers in the case body. Carefully align the Drawer Guides on each drawer with the Drawer Guides on the case. Push the drawer STRAIGHT in until it "clicks". Check that each side is fully secure. Open and close the drawer to ensure smooth operation. Changing the locations may improve fit or performance.

Instale las gavetas en el cuerpo del mueble. Alinee cuidadosamente las guías de gaveta en cada una de ellas con las guías del cuerpo del mueble. Presione la gaveta EN LÍNEA RECTA hasta que haga "clic". Revise que cada lado esté bien asegurado. Abra y cierre la gaveta para asegurarse de que funciona correctamente. Cambiar las ubicaciones podría mejorar el funcionamiento.

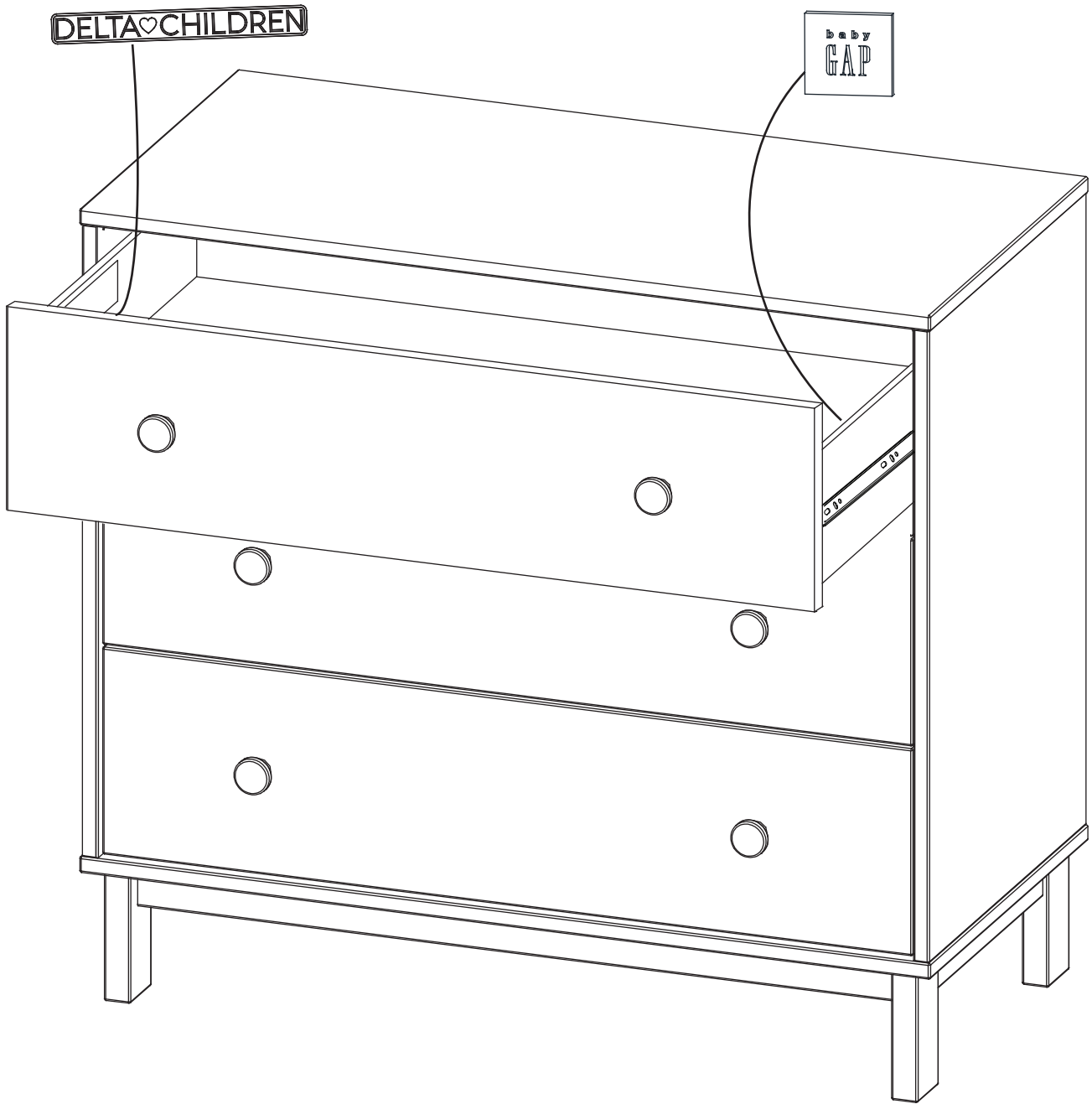

Limited Warranty:

This Delta Product is warranted to be free from defects for a period of 90 days from the date of purchase under normal use. If a product is defective during this period, we will at our option repair or replace the defective part or product. This limited warranty extends only to the original retail purchaser and is valid only when supplied with proof of purchase, or if received as a gift, when the registration is on file with Delta. This limited warranty does not cover the following:

- Products purchased as floor models or samples.
 - Items purchased on an “as-is” basis, as a second hand product, or as a resale product.
 - Items purchased at a Final sale, a “Going out of Business” sale or a Liquidation sale.
- This limited warranty gives you specific legal rights and you may also have other rights which vary from state to state.

To register your product

for important safety alerts and updates to your product please visit
www.deltachildren.com

To report a problem

please log on to www.deltachildren.com/help

Date of Purchase: _____ (you should also keep your receipt)

Garantía Limitada:

Este Producto Delta está garantizado de estar libre de defectos por un período de 90 días a partir de su adquisición, bajo uso normal. Si un producto tiene defectos durante este período, Nosotros tomaremos la opción de reparar o reemplazar la pieza defectuosa del producto. Esta garantía limitada se otorga únicamente al comprador original y es válida solamente cuando se proporciona una prueba de compra, o si el producto fue recibido como un regalo, debe haber sido registrado con Delta. Esta garantía limitada del fabricante no cubre lo siguiente:

- Productos comprados como exhibiciones de la tienda o muestras.
- Artículos comprados como “tal como está”, productos de segunda mano o reventa de los productos.
- Artículos comprados como “venta final”, “ventas de tiendas que están quebrando” o ventas por liquidación.

Esta garantía limitada le otorga derechos legales específicos y también puede tener otros derechos que varían de un estado a otro.

Para registrar su producto

para alertas importantes de seguridad y estar al tanto sobre novedades de su producto por favor visite
www.DeltaChildren.com

Para reportar cualquier problema

por favor entre a www.DeltaChildren.com/help

Fecha de Compra: _____ (debe además mantener su recibo)

SAFETY LEADERS

Visit Deltachildren.Com/Pages/Leaders-In-Safety for more information

SAFE MATERIALS

Safe products start with safe materials. We test all of our products to create the safest and healthiest environment for your baby.



PRODUCTS YOU CAN TRUST

We have 8 cutting edge safety labs around the world where we test our products above and beyond the industry standards. All of our dressers are engineered to meet or exceed ASTM Furniture Safety Standards.



WE GO ABOVE & BEYOND

To protect your children, Delta Children dressers are tested to meet the requirements of the industry tip over test set forth by ASTM. For additional security, we strongly recommend that all dressers in you home be anchored; all Delta Children dressers include a wall anchor.



LÍDERES EN LA SEGURIDAD

Visite Deltachildren.Com/Pages/Leaders-In-Safety para más información

MATERIALES SEGUROS

Los productos seguros se hacen con materiales seguros. Ponemos a prueba todos nuestros productos para crear el ambiente más seguro y saludable para su bebé.



PRODUCTOS CONFIABLES

Tenemos 8 laboratorios de seguridad de alta tecnología donde probamos nuestros productos mas allá de los estándares de la industria. Todos nuestros tocadores están diseñados para cumplir o exceder los estándares de seguridad ASTM de muebles.



ESTAMOS POR ENCIMA Y MÁS ALLÁ

Para proteger a sus niños, los tocadores de Delta Children son sometidos a pruebas para que cumplan los requisitos ASTM establecidos de la industria en cuanto a volcamientos se refiere.

Para seguridad adicional, recomendamos enfáticamente que todos los tocadores de su casa estén fijos: todos los tocadores de Delta Children incluyen un anclaje de pared.

