

DELTA♥CHILDREN™ Upholstered Rocker

Read all instructions
before assembly and use.

**KEEP INSTRUCTIONS FOR
FUTURE USE.**



**To Make Assembly Even
Easier Watch Video Here!**

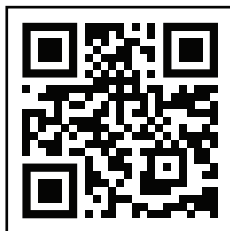

**For Questions or
to Contact Us:**

DeltaChildren.com/Help

If unable to access website, please email
wcs@DeltaChildren.com

Expect longer response times via email.

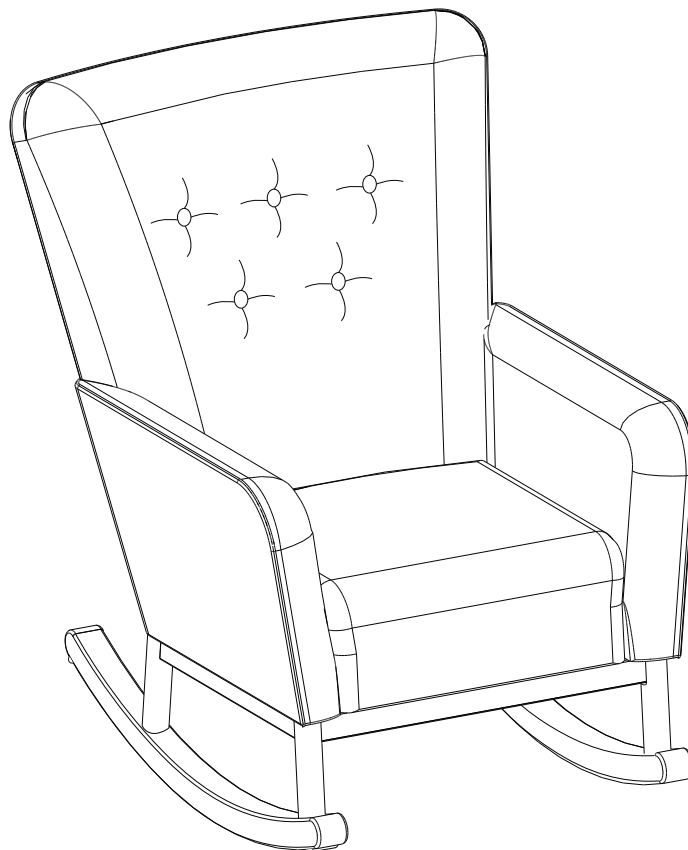

Style #: _____
A Lot: _____
REV Date: _____

Before contacting Delta Consumer
Experience Center please ensure this
information matches the information
found on the Seat Base.



ADULT ASSEMBLY REQUIRED

Due to the presence of small parts during assembly,
keep out of reach of children until assembly is complete.

This product is not intended for institutional or commercial use.

March 21, 2023, 43462, R1

Lea todas las instrucciones antes de ensamblar y usar.

MANTENGA LAS INSTRUCCIONES PARA SU USO FUTURO.

ES

Para facilitar más aun el ensamblaje ver el video aquí



Para preguntar o para contactarnos :

DeltaChildren.com/Help

Si no puede acceder el sitio web, por favor envíenos un email a wcs@DeltaChildren.com

El tiempo de espera para respuestas será más largo por email.

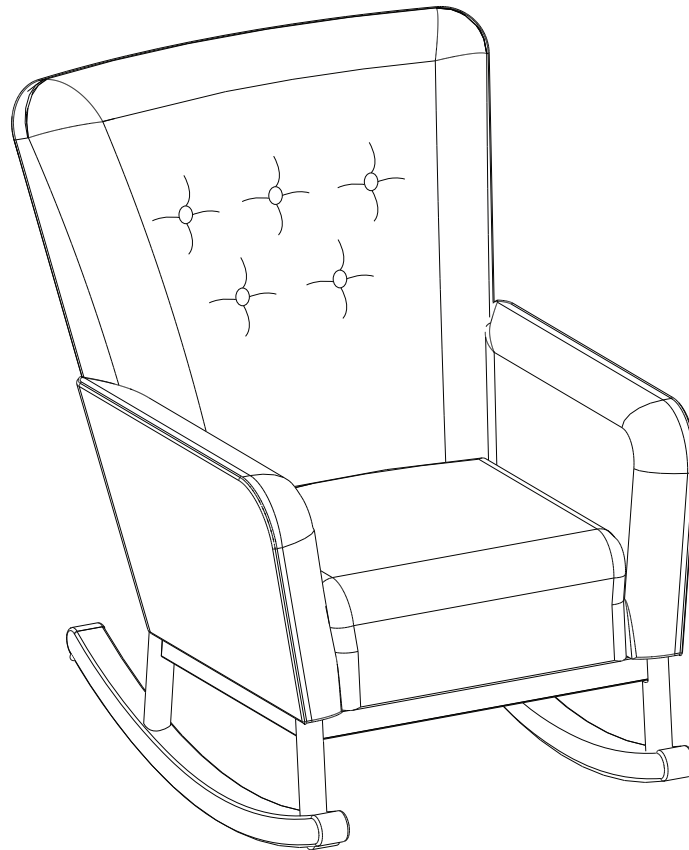

DEBE SER ENSAMBLADO POR UN ADULTO

Debido a la presencia de piezas pequeñas durante el ensamblaje, mantenga fuera del alcance de los niños hasta que complete el ensamblaje.

Antes de contactar el Centro de Experiencia del Consumidor de Delta por favor asegúrese de que la información de la primera página coincida con la información que se encuentra en la etiqueta en Base.

Este producto no esta hecho para uso institucional o comercial.

FABRIC CARE INSTRUCTIONS:

- Only mild, water-free cleaning solvents should be used.
- Never use water. Tap water contains minerals that may cause rings or fading.
- Do not use bleach.
- Do not dry clean individual parts.

Instrucciones para el cuidado de la tela:

- Solo deben ser usados solventes de limpieza suaves y sin -contenido de agua. Nunca utilice agua. El agua del grifo contiene -minerales que pueden ocasionar círculos o decoloración.
- No utilice blanqueadores.
- No lave al seco los componentes individuales.

**Check all fasteners periodically for tightness.
Revise todas las correas periódicamente para verificar su firmeza.**

SAVE BIG WITH DELTA CHILDREN

Visit **Deltachildren.com** To Start Shopping

Welcome to the
DELTA FAMILY
Here's a Gift From Us To You

**10%
OFF**

Your Next Purchase From
DeltaChildren.com

USE CODE:
DELTA10

*Exclusions Apply
*Subject to Change

REVIEW TO WIN \$2500

RULES TO ENTER



"We LOVE, LOVE, LOVE this crib"

My husband was impressed with the directions and organization of the hardware package. He easily assembled this crib in an hour without any help. It's very sturdy and we like that it has adjustable levels for the mattress height. To top it all off, it's so incredibly darling!!!

- 1** **WRITE A REVIEW** for this product on the store's website from where it was purchased
- 2** **TAKE A SCREENSHOT** of your review and upload it to www.DeltaChildren.com/Review
- 3** **IT'S THAT EASY!** Upon submission, you'll be instantly **ENTERED TO WIN \$2,500**

FOLLOW US FOR MORE CHANCES TO WIN

   
@deltachildren

SCAN HERE



For more
information &
to see all of
our products

AHORRE MUCHO CON DELTA CHILDREN

Visita **Deltachildren.com** Para Comenzar A Comprar

Bienvenido a la
FAMILIA DELTA

Aquí Está Nuestro Regalo
Para Usted

**10%
OFF**

Su Próxima Compra En
DeltaChildren.com

UTILICE EL CÓDIGO:
DELTA10

*Exclusions Apply
*Subject to Change

CALIFIQUE EL PRODUCTO PARA **GANAR \$2500**

REGLAS PARA PARTICIPAR



- 1 **CALIFIQUE EL PRODUCTO** en la página web de la tienda donde haya sido comprado
- 2 **HAGA UNA CAPTURA DE PANTALLA** de su calificación y cárguela a la pagina www.DeltaChildren.com/Review
- 3 **ES ASÍ DE FÁCIL!** En cuanto lo envíe ya estará instantáneamente **PARTICIPANDO PARA GANAR \$2.500**

SÍGANOS PARA TENER MAS CHANCES DE GANAR



@deltachildren

ESCANEE AQUÍ

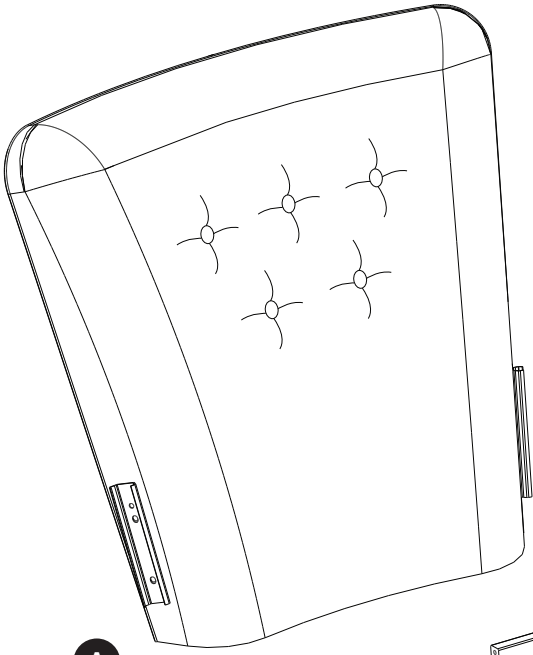

Para más
información
y para ver todos
nuestros productos

PARTS: MAKE SURE THAT ALL PRE-ASSEMBLED PARTS ARE TIGHT
PIEZAS: ASEGÚRESE DE QUE TODAS LAS PIEZAS PRE-ENSAMBLADAS ESTÁN BIEN APRETADAS.



A

Seat Back x 1
 Respaldo de la silla x 1
 #43465

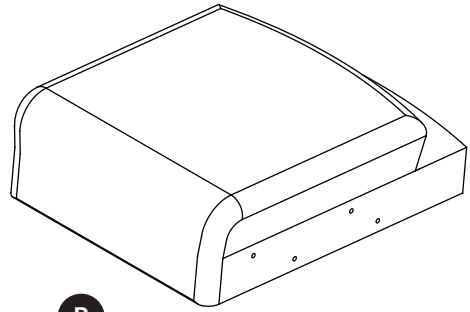

B

Seat Base x 1
 Base x 1
 #43464

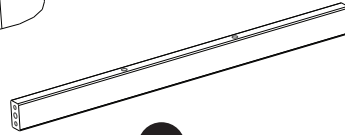

D

Foot Front Rail x 1
 Barra frontal de la pata x 1
 #43470

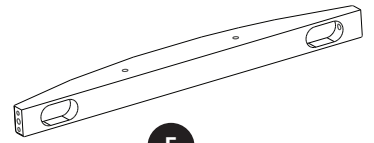

E

Foot Back Rail x 1
 Barra trasero de la pata x 1
 #43471

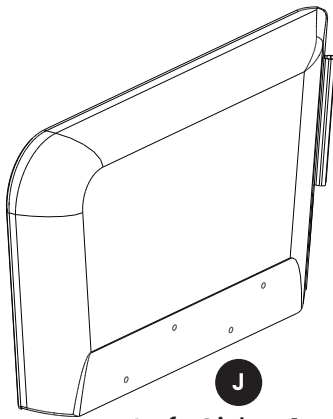

J

Left Side x1
 Lado izquierdo
 #43466

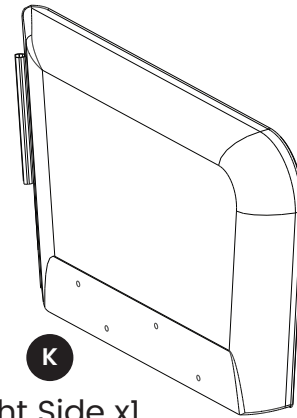

K

Right Side x1
 Lado derecho
 #43467

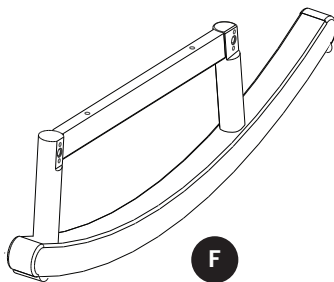

F

Left Rocking Foot x 1
 Pata balancín izquierda x 1
 #43468

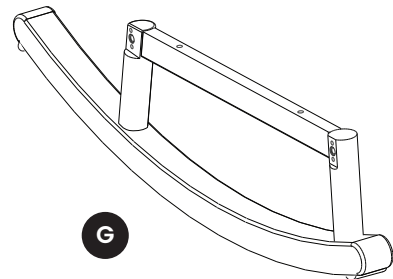

G

Right Rocking Foot x 1
 Pata balancín derecha x 1
 #43469

PARTS: HARDWARE KITS PART#43463

PIEZAS: EL KIT DE HERRAMIENTAS - PIEZA #43463

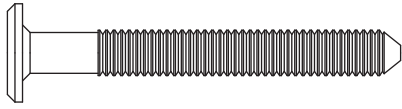
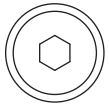

AA 50mm Bolt x21
Perno 50mm
#5467

DD Crescent Washer x4
Arandela de media luna
#5202

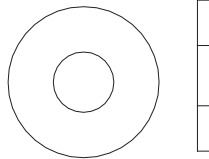

EE Washer x2
Rondelle
5788

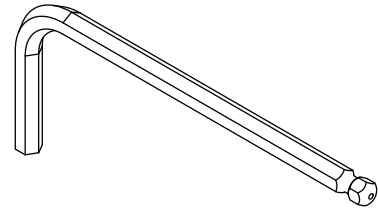

M5 Allen Wrench x1
Llave Allen M5

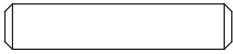

CC Φ 6x30mm Dowel x8
Pasador Φ 6x30mm
#4491

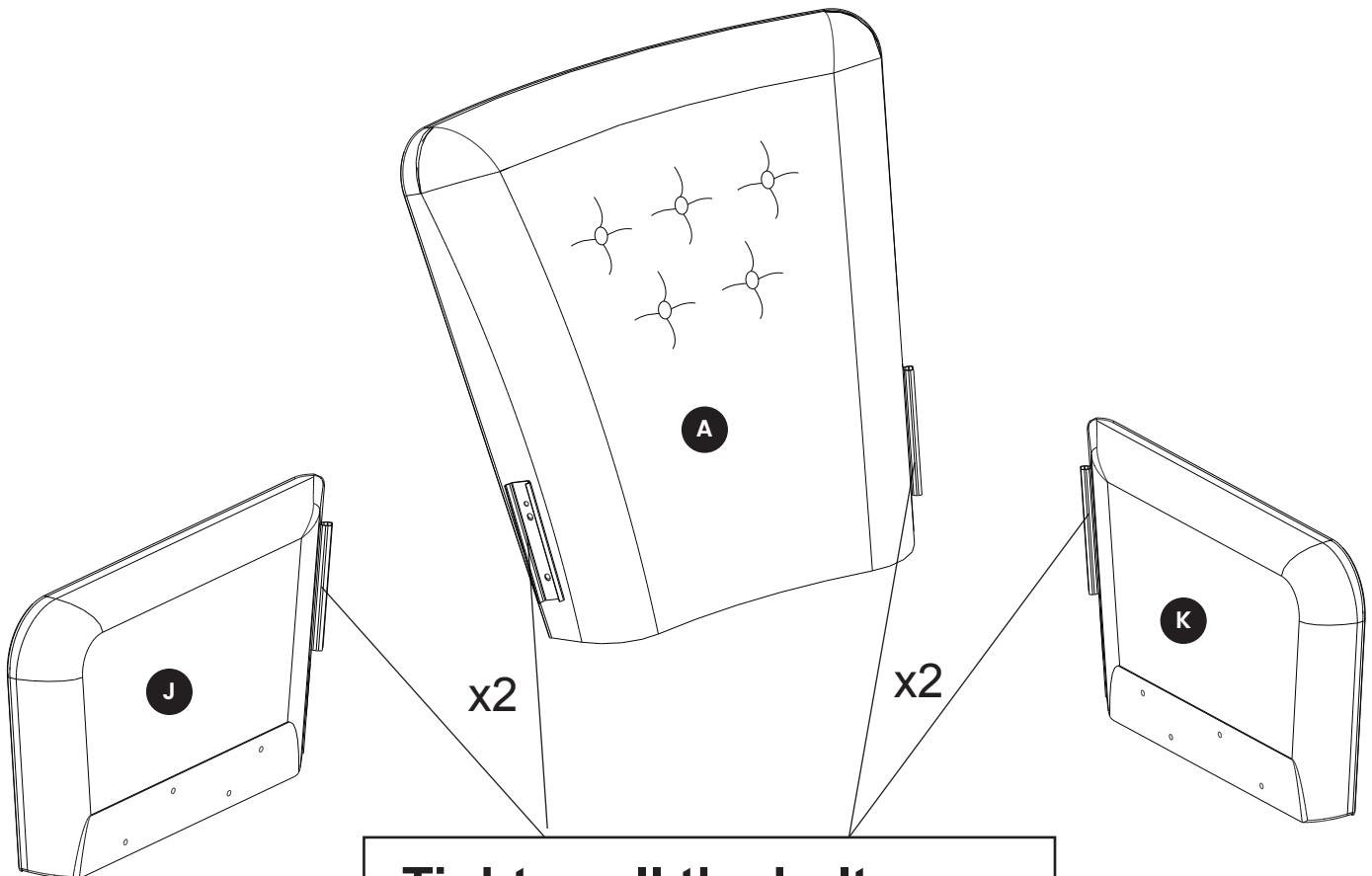

**Tighten all the bolts.
Apriete todos los pernos**

STEP 1
PASO 1

Parts and tools required to complete step

Piezas y herramientas necesarias para completar este paso

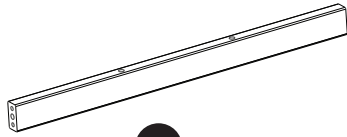

D

Foot Front Rail x 1
Barra frontal de la pata x 1

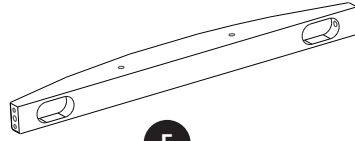

E

Foot Back Rail x 1
Barra trasero de la pata x 1

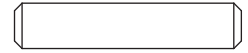

CC

Φ6x30mm Dowel x8
Pasador Φ6x30mm

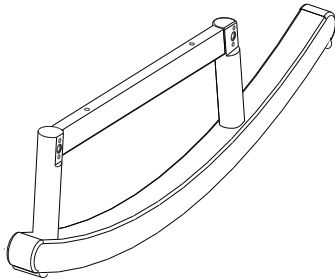

F

Left Rocking Foot x 1
Pata balancín izquierda x 1

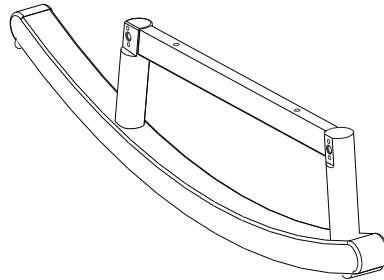

G

Right Rocking Foot x 1
Pata balancín derecha x 1



DD

Crescent Washer x4
Arandela de media luna

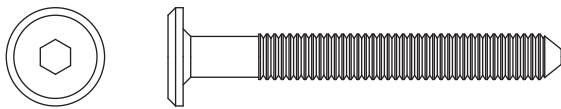

AA

50mm Bolt x4
Perno 50mm

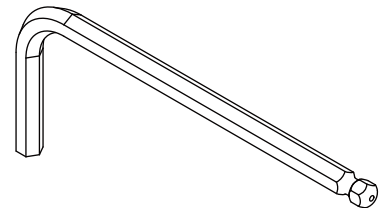

M5 Allen Wrench x1
Llave Allen M5

Attach the Foot Front Rail (Part D) and the Foot Back Rail (Part E) to the Left Rocking Foot (Part F) and the Right Rocking Foot (Part G) using (8) Φ 6x30mm Dowels (Part CC), (4) M6 x 50 mm Bolts (Part AA) and (4) Half Moon Washer (Part DD). Tighten with the M5 Allen Wrench.

DO NOT Tighten the bolts at this time, they should be loose

Fije el Barra frontal de la pata (pieza D) y Barra trasero de la pata (pieza E) a la pata balancín izquierda (pieza F) y pata balancín derecha (pieza G) utilizando (8) Pasadors Φ6x30mm (Pieza CC), (4) pernos M6 x 50 mm (pieza AA) y (4) arandelas de media luna (pieza DD). Apretar con la llave Allen M5.

NO apriete los pernos en este punto, deben quedar sueltos por ahora.

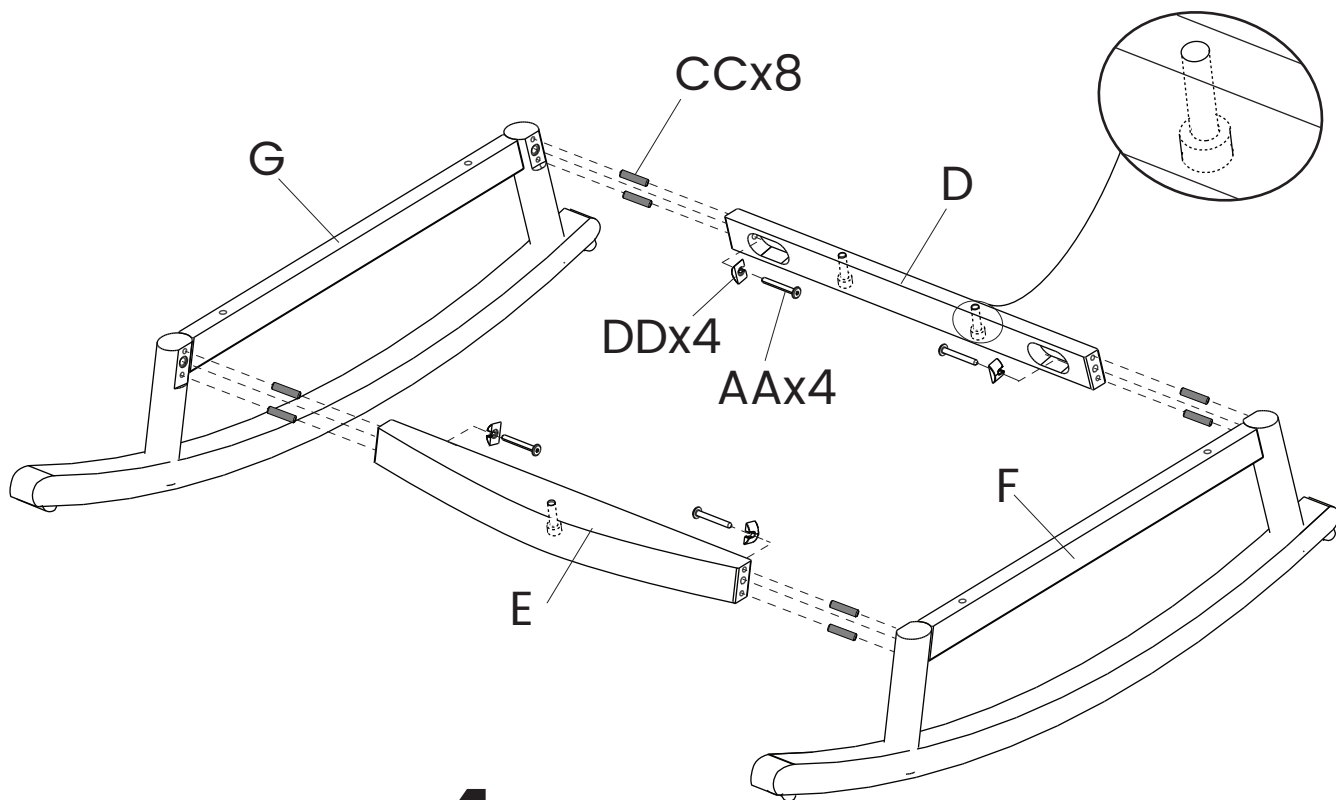

x4

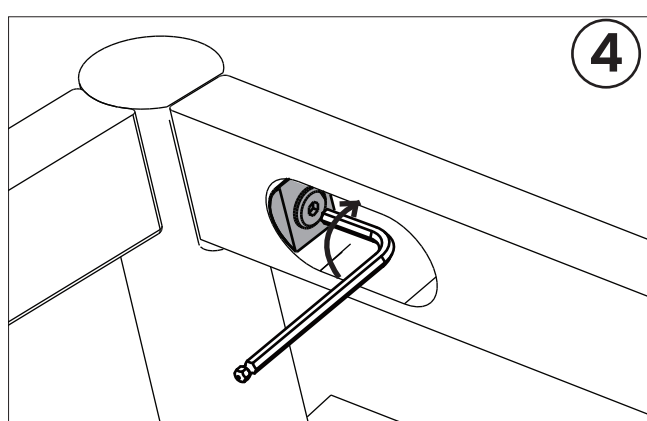
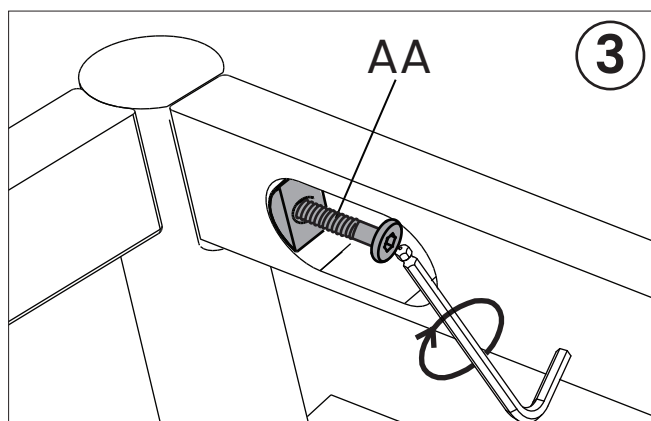
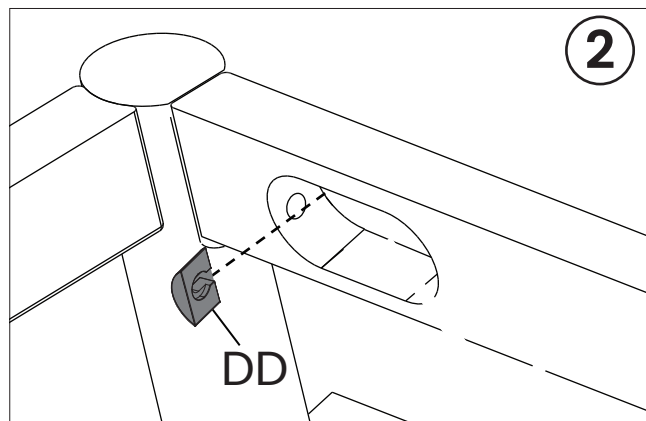
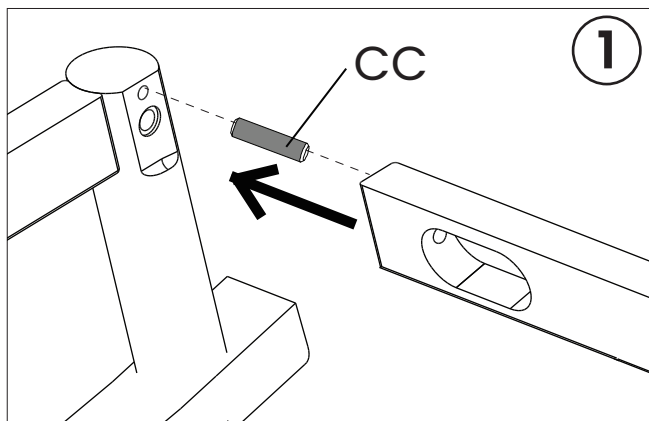

STEP 2
PASO 2

Parts and tools required to complete step
Piezas y herramientas necesarias para completar este paso

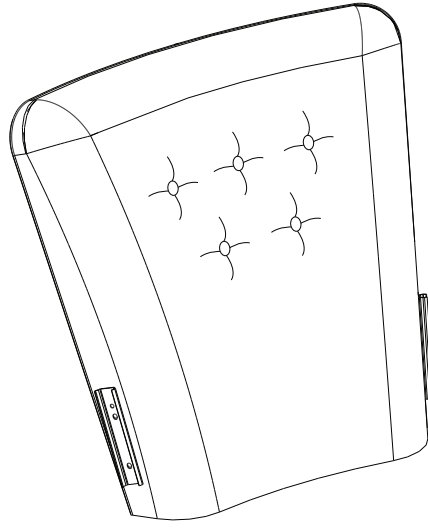

A

Seat Back x 1
Respaldo de la silla x 1

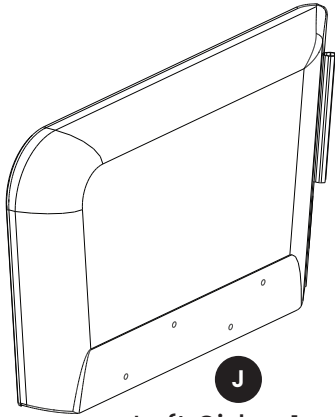

J

Left Side x1
Lado izquierdo

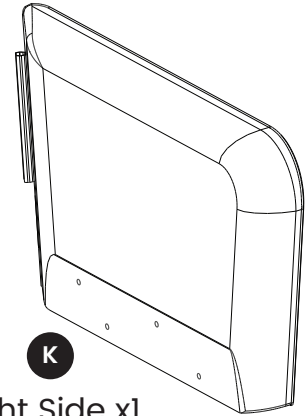



K

Right Side x1
Lado derecho

Attach the Seat Back (Part A) to the Left Side (Part J) and the Right Side (Part K).

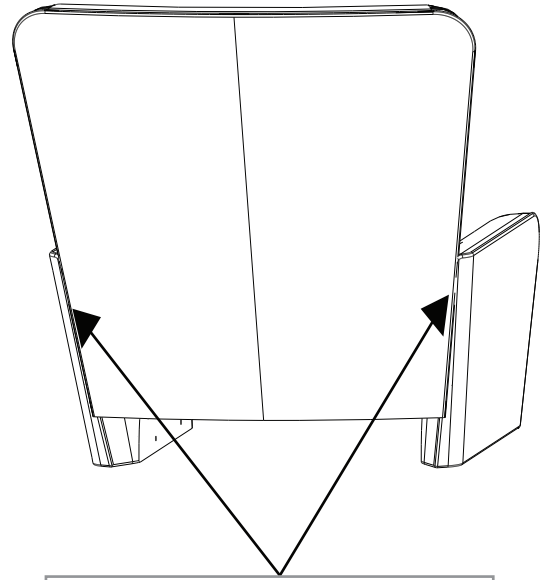
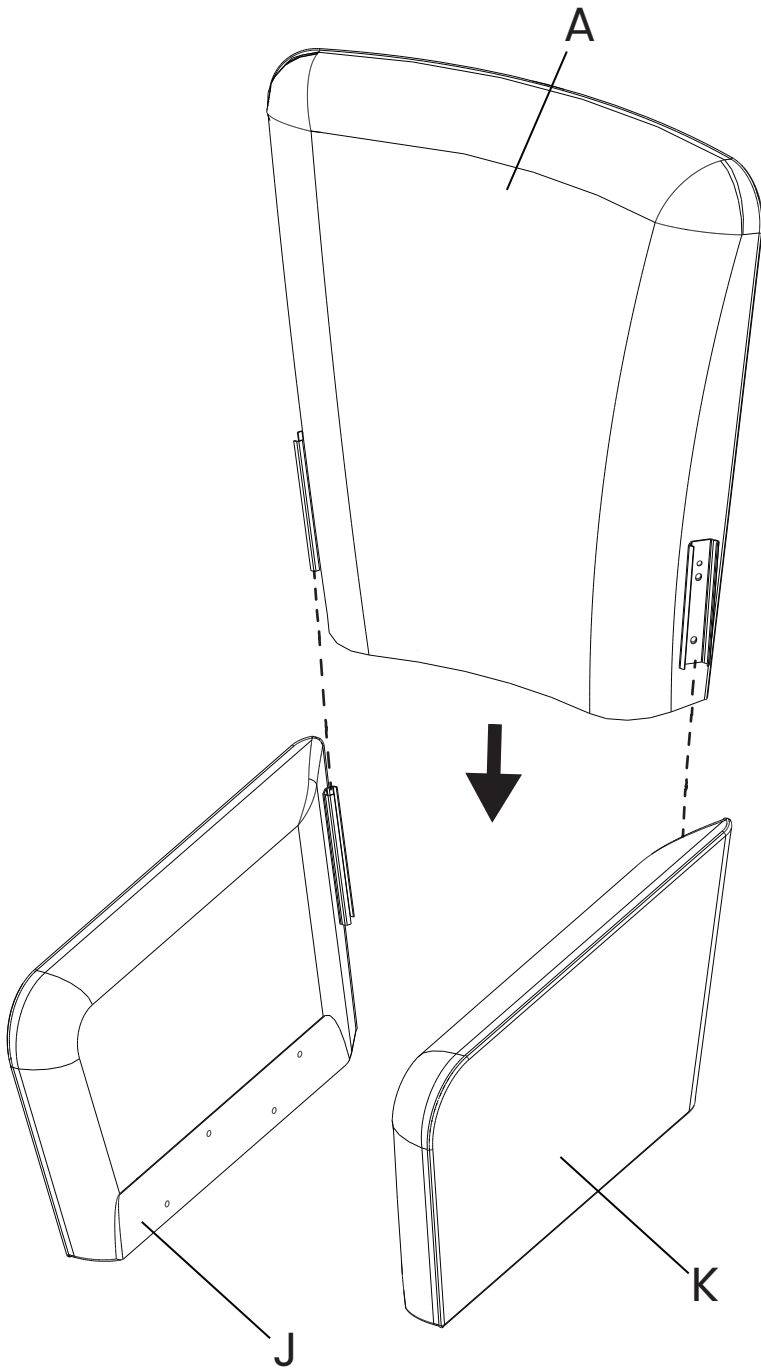
Attacher le dossier du siège (pièce A) à la Lado izquierdo (pièce J) y la Lado derecho (pièce K).





Seat Base
Base



Seat Back
Dossier du siège

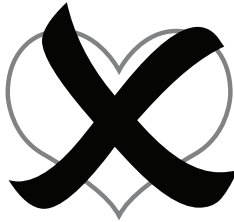

Seat Base
Base

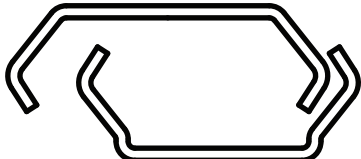

Seat Back
Dossier du siège

STEP 3 PASO 3

Parts and tools required to complete step

Piezas y herramientas necesarias para completar este paso

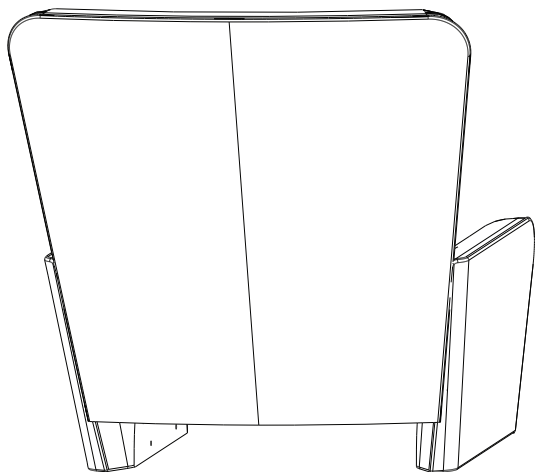

From Step 2
Desde el paso 2

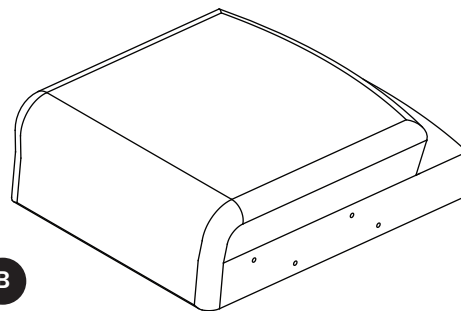

B
Seat Base x 1
Base x 1

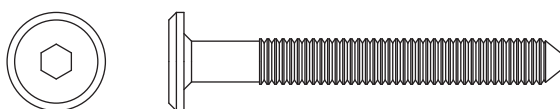

AA 50mm Bolt x2
Perno 50mm

Attach the Seat Base (Part B) using (2) 50 mm Bolts (Part AA) by hand, screwing them into the holes.

DO NOT Tighten the bolts at this time, they should be loose.

Fije el Base (pieza B) utilizando (2) pernos de 50mm (pieza AA), atornillando a mano.

NO apriete los pernos en este punto, deben quedar sueltos por ahora.

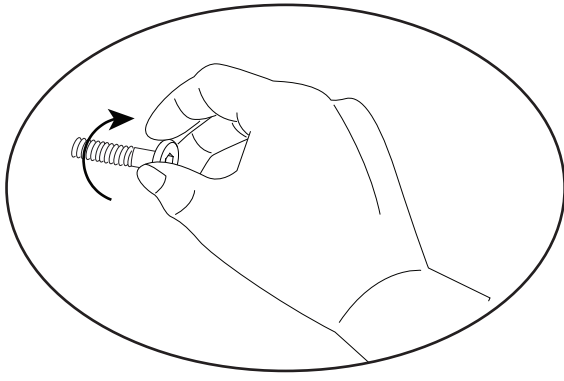

x2

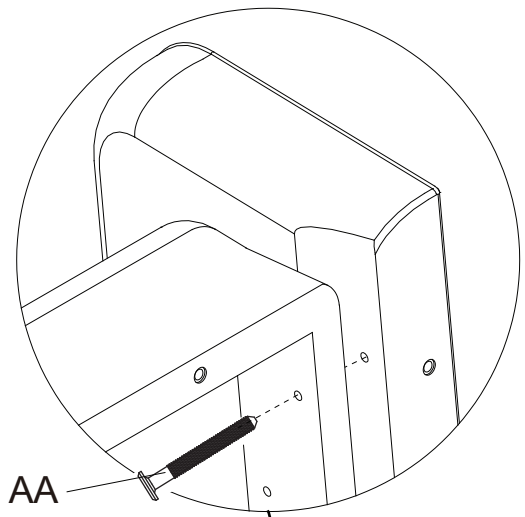
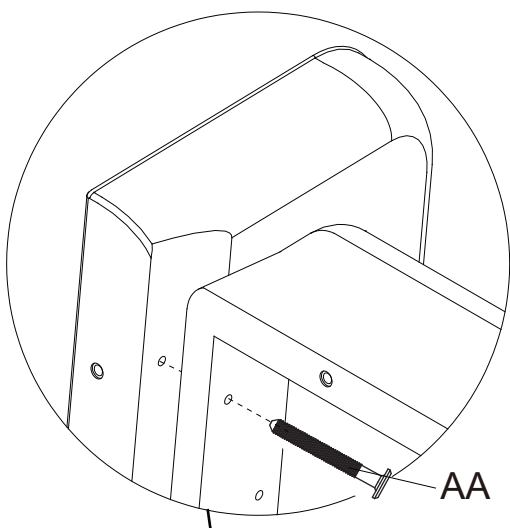

PULL GENTLY
SAQUE CON
CUIDADO

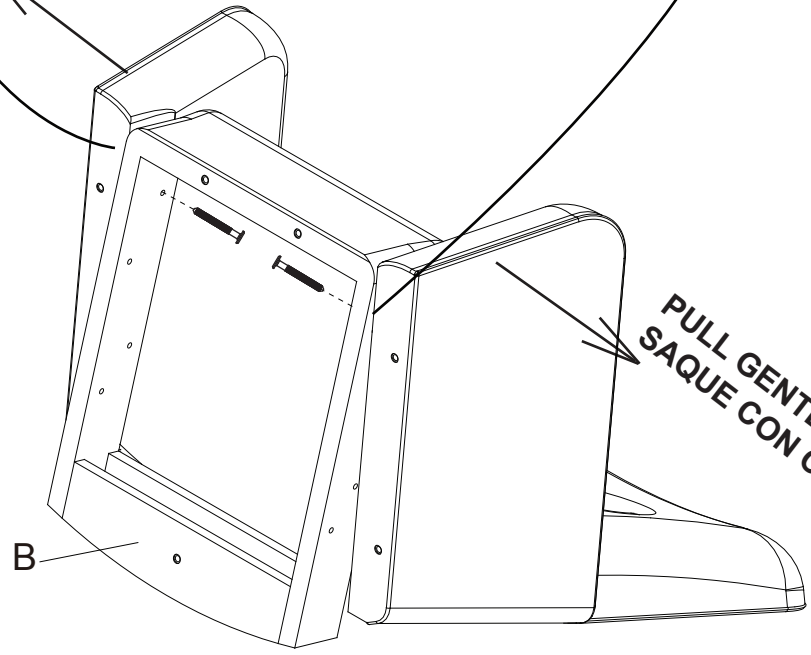

PULL GENTLY
SAQUE CON
CUIDADO

STEP 4 PASO 4

Parts and tools required to complete step

Piezas y herramientas necesarias para completar este paso

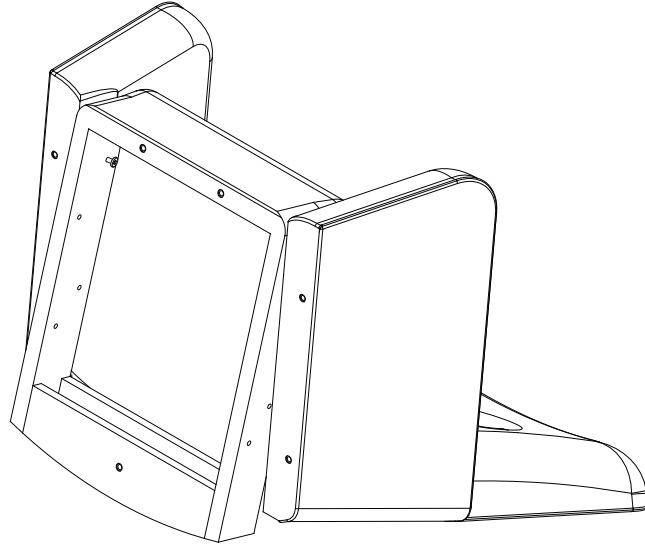

From Step 3
Desde el paso 3

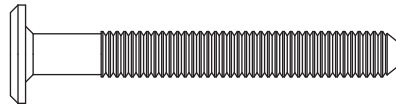
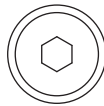

AA

50mm Bolt x6
Perno 50mm

Attach the Seat Base (Part B) using (6)
50 mm Bolts (Part AA) by hand,
screwing them into the holes.

**DO NOT Tighten the bolts at this time,
they should be loose.**

Fije el Base (pieza B) utilizando (6)
pernos de 50mm (pieza AA),
atornillando a mano.

**NO apriete los pernos en este punto,
deben quedar sueltos por ahora.**

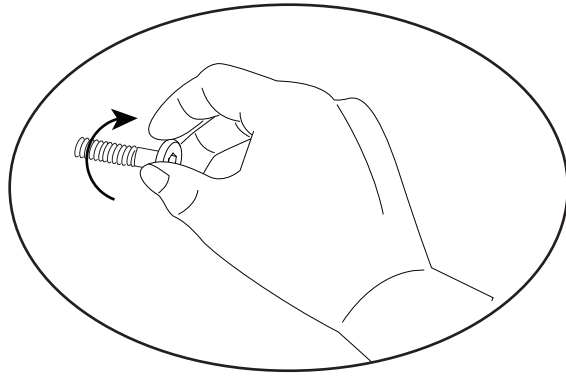

x6

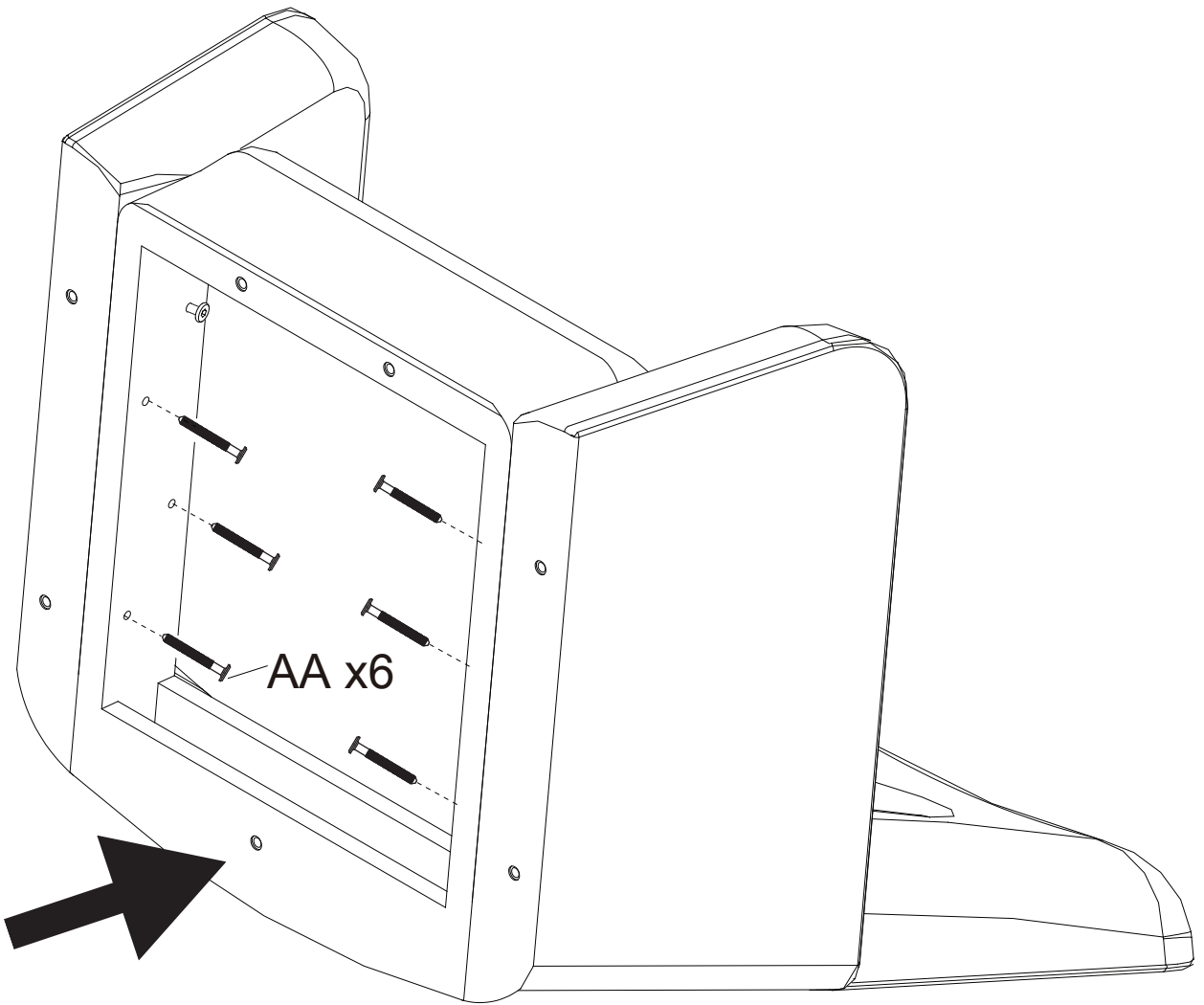

STEP 5 PASO 5

Parts and tools required to complete step

Piezas y herramientas necesarias para completar este paso

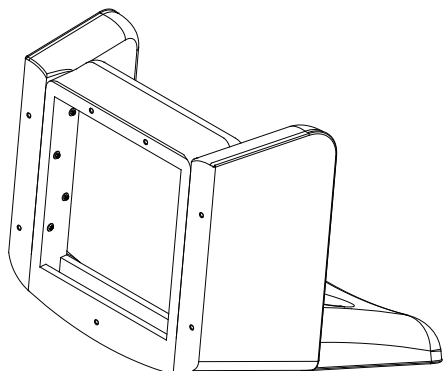

From Step 4
Desde el paso 4

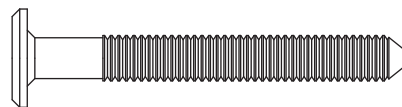

AA

50mm Bolt x6
Perno 50mm

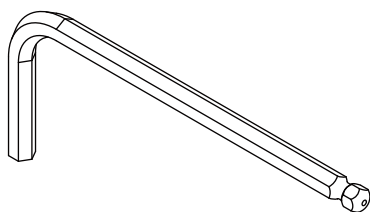

M5 Allen Wrench
Llave Allen M5

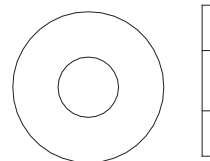

EE

Washer x2
Rondelle

Attach the Seat Back (Part A) using (2) 50 mm Bolts (Part AA), and (2) Washers (Part EE) With M5 Allen Wrench .

DO NOT Tighten the bolts at this time, they should be loose.

Attacher le dossier du siège (pièce A) utilisant (2) pernos de 50mm (pièce AA) y (2) Rondelle (pièce EE). Apriete con la Llave Allen M5.

NO apriete los pernos en este punto, deben quedar sueltos por ahora.

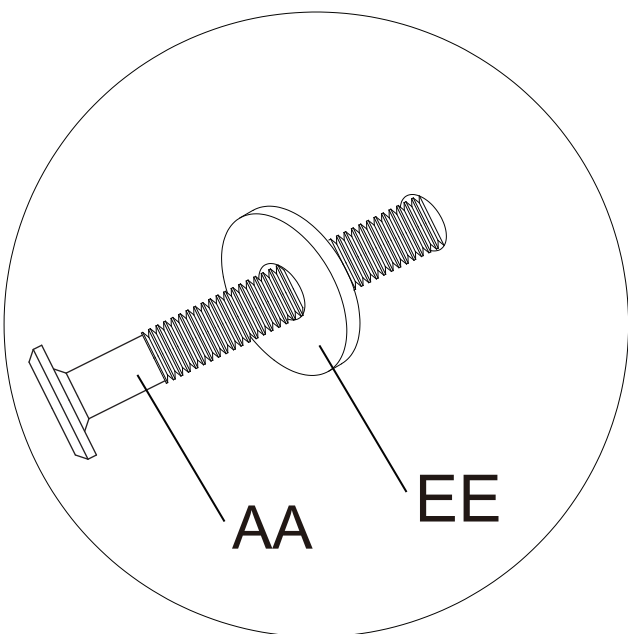
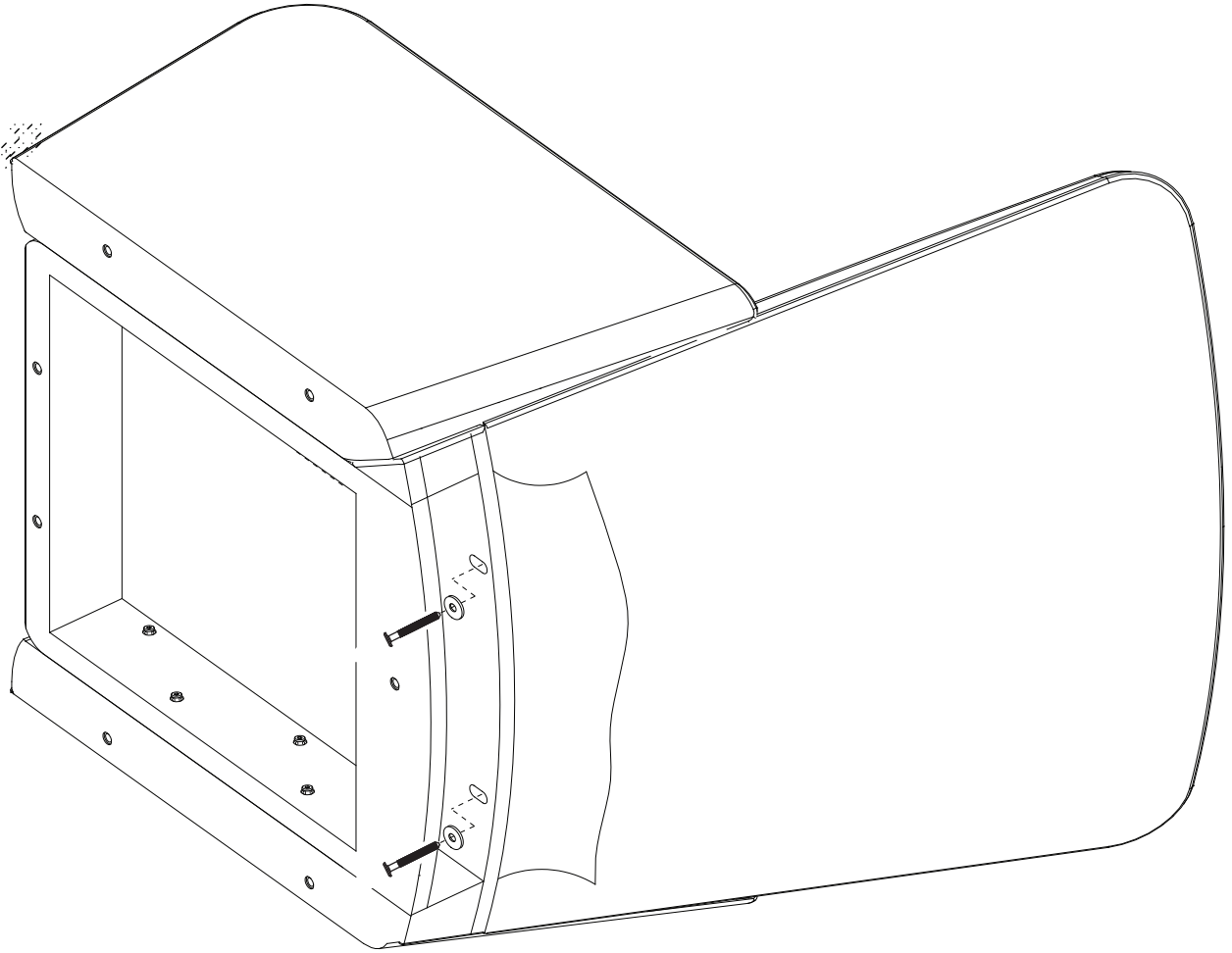

x2

STEP 6
PASO 6

Parts and tools required to complete step
Piezas y herramientas necesarias para completar este paso

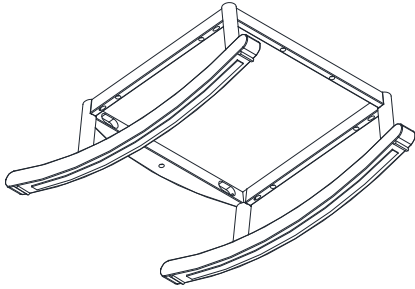

From Step 1
Desde el paso 1

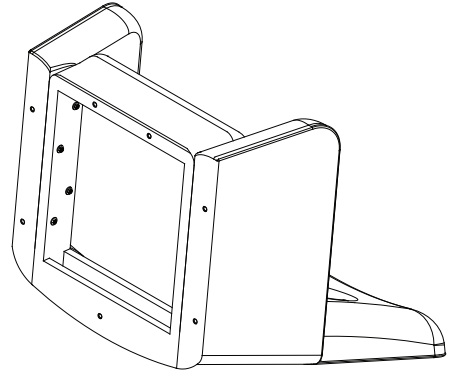

From Step 5
Desde el paso 5

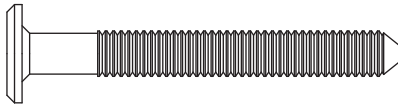

AA 50mm Bolt x7
Perno 50mm

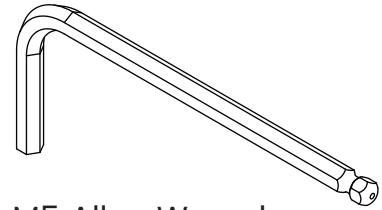

M5 Allen Wrench
Llave Allen M5

Attach the assembly from step 1 to the assembly from step 5 using (7) 50mm Bolts (Part AA)

Tighten ALL bolts with the M5 Allen wrench, including those left loose in steps 1,3,4 and 5.

Fijar lo ensamblado en el paso 1 a la ensamblado en el paso 5 utilizando (7) pernos 50mm (pieza AA) .

Apretar todos los tornillos, incluyendo los que se habían dejado sueltos en los pasos 1,3,4 y 5 con la Llave Allen M5.

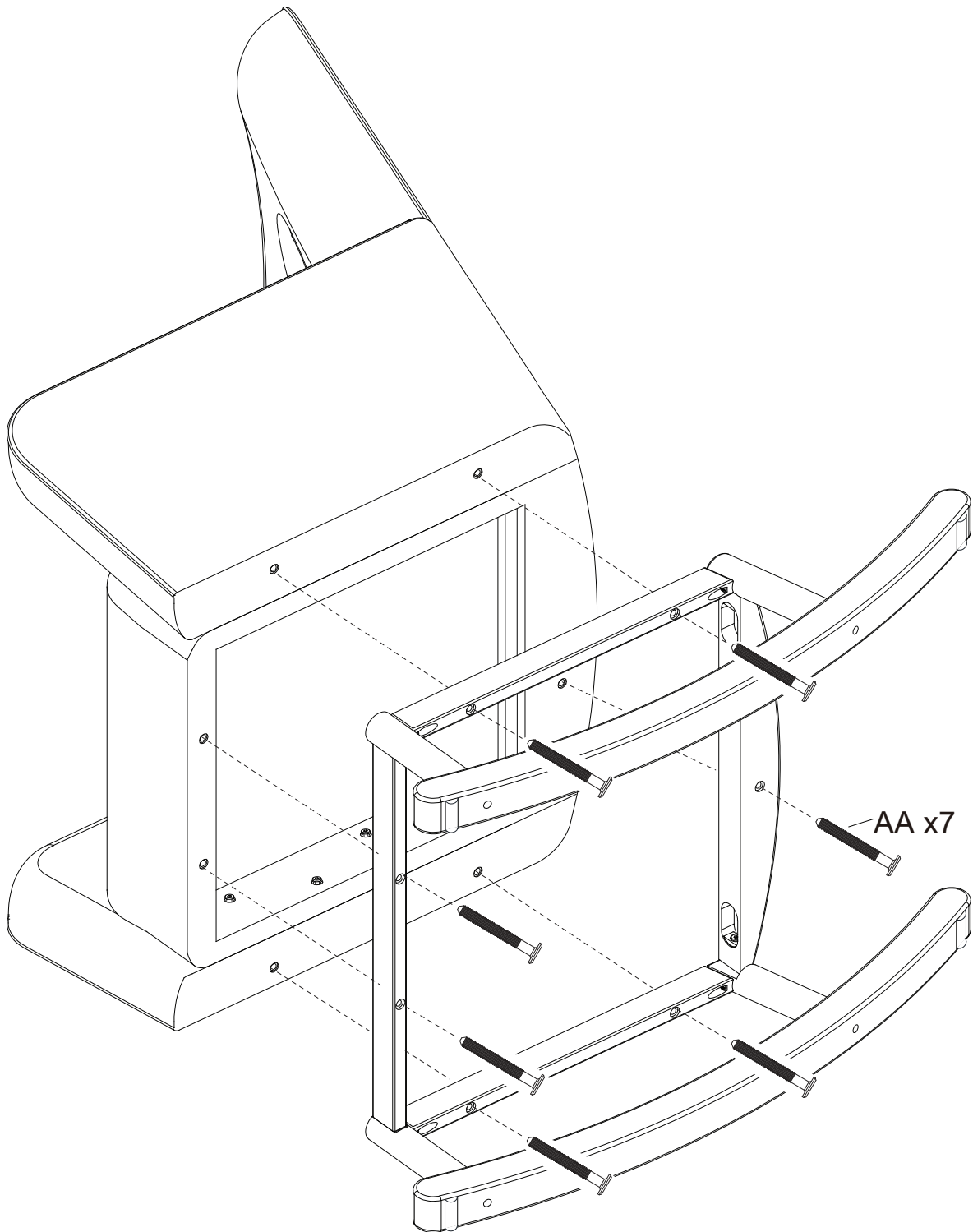

STEP 7
PASO 7

Parts and tools required to complete step

Piezas y herramientas necesarias para completar este paso

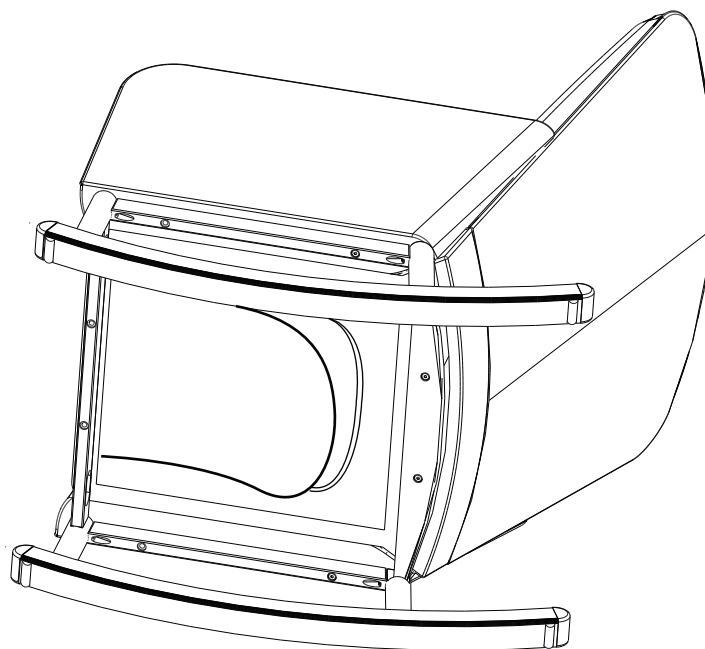

From Step 6
Desde el paso 6

Close the bottom and the back access flap using the sewn Velcro.

Cierre la parte inferior y la solapa de acceso posterior con el velcro cosido.

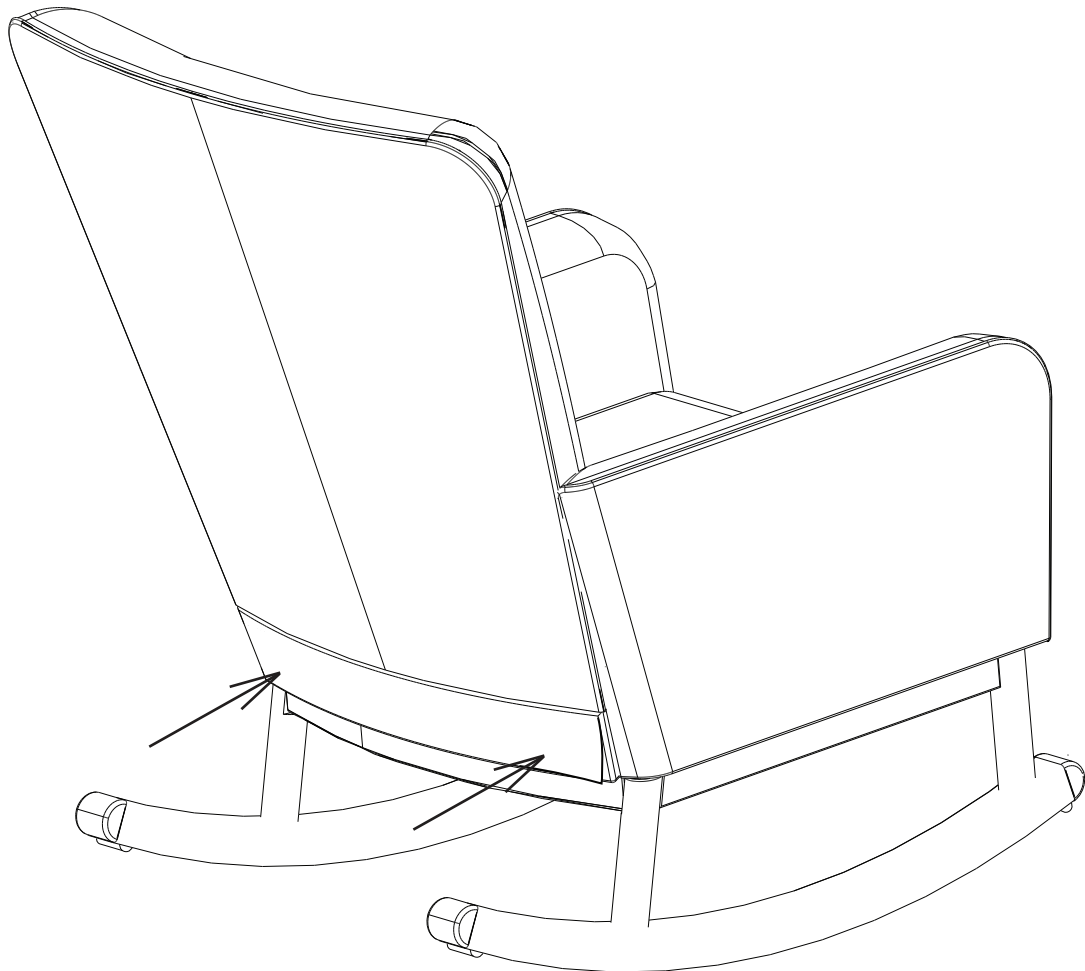
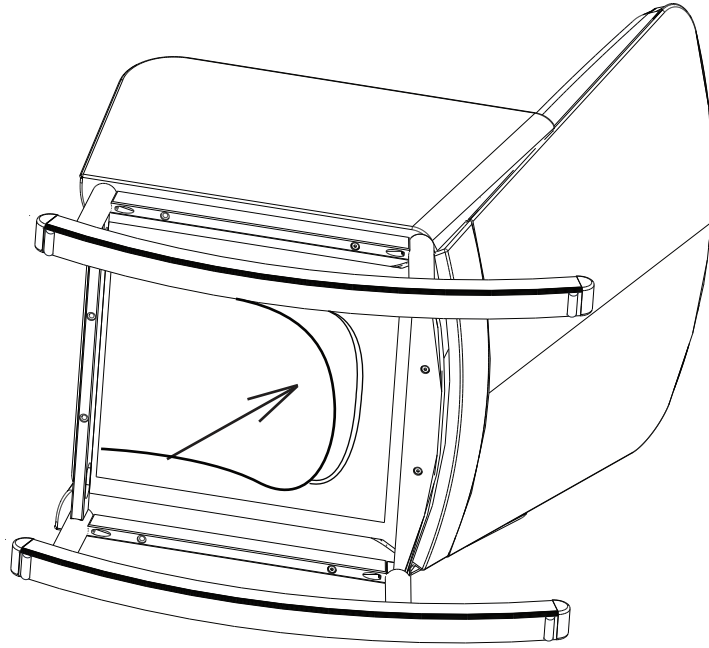

Limited Warranty:

This Delta Crib is warranted to be free from defects for a period of 90 days from the date of purchase under normal use. If a product is defective during this period, we will at our option repair or replace the defective part or product. This limited warranty extends only to the original retail purchaser and is valid only when supplied with proof of purchase, or if received as a gift, when the registration is on file with Delta. This limited warranty does not cover the following:

- Products purchased as floor models or samples.
- Items purchased on an “as-is” basis, as a second hand product, or as a resale product.
- Items purchased at a Final sale, a “Going out of Business” sale or a Liquidation sale.

This limited warranty gives you specific legal rights and you may also have other rights which vary from state to state.

To register your product

for important safety alerts and updates to your product please visit
www.deltachildren.com

To report a problem

please log on to www.deltachildren.com/help

Date of Purchase: _____ (you should also keep your receipt)

Garantie Limitée:

Ce Produit Delta est garanti libre de défauts pour une période de 90 jours à partir de sa date achat et dans des conditions normales d'utilisation. Si un produit se révèle défectueux pendant cette période, nous opterons soit pour une réparation, un remplacement de la pièce défectueuse ou le remplacement du produit. Cette garantie limitée se donne uniquement à l'acheteur d'origine et elle est valable seulement sur présentation d'une preuve d'achat, ou si le produit a été reçu en tant que cadeau alors il doit avoir été enregistré chez Delta. Cette garantie limitée du fabricant ne couvre pas les cas suivants :

- Produits achetés comme modèles d'exposition ou échantillons.
- Articles achetés comme « en l'état », produits d'occasion ou revente des produits.
- Articles achetés en « vente finale », ventes dans « magasins en faillite » ou ventes par liquidation.

Cette garantie limitée vous donne des droits légaux spécifiques et il se peut aussi que vous ayez d'autres droits qui varient d'un État à un autre.

Pour enregistrer votre produit

pour avoir les alertes de sécurité et les mises à jour de votre produit veuillez visiter
www.DeltaChildren.com

Pour signaler un problème,

veuillez vous connecter a www.DeltaChildren.com/help

Date d'Achat: _____ (vous devriez aussi garder votre facture d'achat)

POURQUOI CHOISIR DELTA CHILDREN?

Visitez Deltachildren.Com/Pages/Our-Story pour plus d'information

DELTA EN TÊTE

Un enfant sur deux
aux U.S.A. dort dans
nos produits

DELTA DONNE

10% de nos revenus
sont dédiés à
l'amélioration de la
vie des enfants

DELTA PREND SOIN

Nous testons la
conformité au-delà
des standards de
sécurité de l'industrie

DELTA EST DÉVOUÉ

familiale a été
présente pour votre
famille depuis 1968

DELTA GRANDIT AVEC VOUS

Nous avons des
produits pour chaque
âge et chaque étape

**Plus De 50 Ans
De Sécurité,
Design &
Innovation**

Bienvenue dans la
FAMILLE DELTA

Voici Notre Cadeau Pour Vous

10% OFF

Votre Prochain Achat Chez
DeltaChildren.com

UTILISEZ LE CODE:
DELTA10

*Des exclusions s'appliquent
*Sujet à changement

DES PRODUITS POUR CHAQUE ÂGE ET CHAQUE ÉTAPE



LITS
POUR BÉBÉ



ÉQUIPEMENT
POUR BÉBÉ



CHAISE



COUFFINS



MATELAS



POUSSETTES

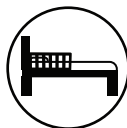

LITS POUR
ENFANT

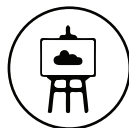

SALLE
DE JEUX



LITS
UNE PLACE



PANIER



COMMODOES

NOTRE FAMILLE DE MARQUES SUPÉRIEURES



PLUS DE 50 ANS DE SÉCURITÉ, DESIGN & INNOVATION

WHY CHOOSE DELTA CHILDREN?

Visit Deltachildren.Com/Pages/Our-Story for more information

<p>DELTA LEADS 1 Out Of 2 Children In The U.S. Sleep In Our Products</p>	<p>DELTA GIVES 10% Of Our Profits Go Toward Improving The Lives Of Children</p>	<p>DELTA CARES We Test Above & Beyond Industry Safety Standards</p>	<p>DELTA IS DEDICATED Our Family-Run Company Has Been There For Your Family Since 1968</p>	<p>DELTA GROWS WITH YOU We Have Products For Every Age And Stage</p>	<p>Over 50 Years Of Safety, Style & Innovation</p>
---	--	--	---	---	---

Welcome to the **DELTA FAMILY**
Here's a Gift From Us To You





10% OFF

Your Next Purchase From DeltaChildren.com

USE CODE:
DELTA10

*Exclusions Apply
*Subject to Change

PRODUCTS FOR EVERY AGE AND STAGE

 CRIBS LITS POUR BÉBÉ CUNAS	 STROLLERS ÉQUIPEMENT POUR BÉBÉ COSAS PARA BEBÉ	 GLIDERS CHAISE SILLA	 BASSINETS COUFFINS MOISÉS	 MATRESSES MATELAS COLCHÓN	
 BABY GEAR POUSSETTES CARRIOLAS	 TODDLER BEDS LITS POUR ENFANT CAMA PARA NIÑO	 PLAYROOM FURNITURE SALLE DE JEUX CUARTO DE JUGAR	 TWIN BEDS LITS UNE PLACE CAMA SENCILLA	 BINS & ORGANIZERS PANIERES CONTENEDORES	 DRESSERS COMMODES TOCADORES

OUR FAMILY OF TOP BRANDS



OVER 50 YEARS OF SAFETY, STYLE, AND INNOVATION