

# DELTA♥CHILDREN™ Changing Table

Read all instructions before assembly and use.

**KEEP INSTRUCTIONS FOR FUTURE USE.**



**To Make Assembly Even Easier Watch Video Here!**

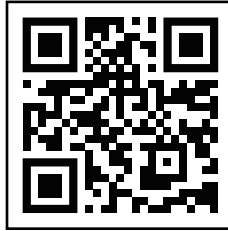

**For Questions or to Contact Us:**

[DeltaChildren.com/Help](https://DeltaChildren.com/Help)

If unable to access website, please email [wcs@DeltaChildren.com](mailto:wcs@DeltaChildren.com)

Expect longer response times via email.

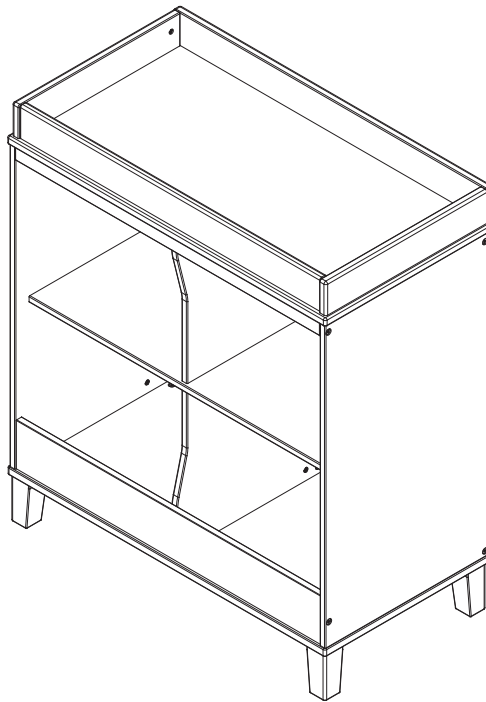

sample tested to meet U.S. Federal, ASTM and other safety requirements

Style #: \_\_\_\_\_  
[B] Lot: \_\_\_\_\_  
REV  
Date: \_\_\_\_\_

Before contacting Delta Consumer Experience Center please ensure this information matches the information found on the label on the Top Shelf.



## ADULT ASSEMBLY REQUIRED

Due to the presence of small parts during assembly, keep out of reach of children until assembly is complete.

This product is not intended for institutional or commercial use.

March 29, 2021, 42053, R0

Lea todas las instrucciones antes de ensamblar y usar.

**MANTENGA LAS INSTRUCCIONES PARA SU USO FUTURO.**



**Para facilitar más aun el ensamblaje ver el video aquí**



**Para preguntar o para contactarnos :**

DeltaChildren.com/Help

Si no puede acceder el sitio web, por favor envíenos un email a [wcs@DeltaChildren.com](mailto:wcs@DeltaChildren.com)

El tiempo de espera para respuestas será más largo por email.

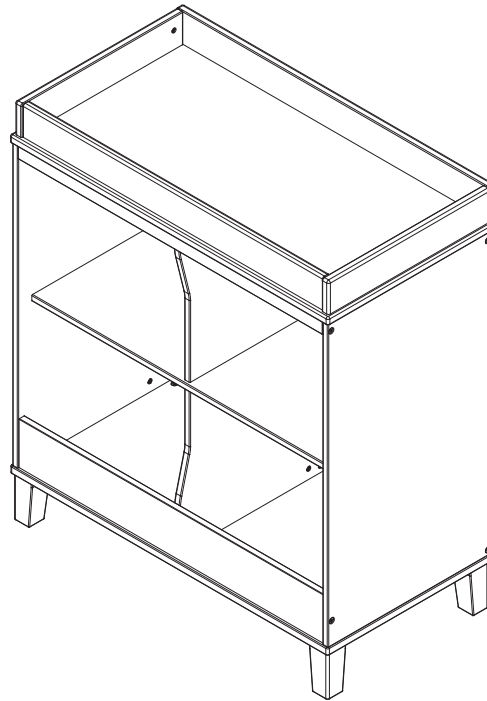

sample tested to meet U.S. Federal, ASTM and other safety requirements

Antes de contactar el Centro de Experiencia del Consumidor de Delta por favor asegúrese de que la información de la primera página coincida con la información que se encuentra en la etiqueta ubicada en el Estante superior.



**DEBE SER ENSAMBLADO POR UN ADULTO**

Debido a la presencia de piezas pequeñas durante el ensamblaje, mantenga fuera del alcance de los niños hasta que complete el ensamblaje.

**Este producto no esta hecho para uso institucional o comercial.**



# SAVE BIG WITH DELTA CHILDREN

Visit **Deltachildren.com** To Start Shopping

Welcome to the  
**DELTA FAMILY**  
Here's a Gift From Us To You

**10% OFF**

Your Next Purchase From  
**DeltaChildren.com**

**USE CODE:  
DELTA10**

\*Exclusions Apply  
\*Subject to Change

**REVIEW TO WIN \$2500**

**RULES TO ENTER**

★ ★ ★ ★ ★

**"We LOVE, LOVE, LOVE this crib"**

My husband was impressed with the directions and organization of the hardware package. He easily assembled this crib in an hour without any help. It's very sturdy and we like that it has adjustable levels for the mattress height. To top it all off, it's so incredibly darling!!!

- 1 WRITE A REVIEW** for this product on the store's website from where it was purchased
- 2 TAKE A SCREENSHOT** of your review and upload it to [www.DeltaChildren.com/Review](http://www.DeltaChildren.com/Review)
- 3 IT'S THAT EASY!** Upon submission, you'll be instantly **ENTERED TO WIN \$2,500**

**FOLLOW US FOR MORE CHANCES TO WIN**



@deltachildren

**SCAN HERE**



For more information & to see all of our products

# AHORRE MUCHO CON DELTA CHILDREN

Visita **Deltachildren.com** Para Comenzar A Comprar

Bienvenido a la  
**FAMILIA DELTA**

Aquí Está Nuestro Regalo  
Para Usted

**10%  
OFF**

Su Próxima Compra En  
**DeltaChildren.com**

UTILICE EL CÓDIGO:  
**DELTA10**

\*Exclusions Apply  
\*Subject to Change

CALIFIQUE EL PRODUCTO PARA **GANAR \$2500**

REGLAS PARA PARTICIPAR



- 1 **CALIFIQUE EL PRODUCTO** en la página web de la tienda donde haya sido comprado
- 2 **HAGA UNA CAPTURA DE PANTALLA** de su calificación y cárguela a la pagina [www.DeltaChildren.com/Review](http://www.DeltaChildren.com/Review)
- 3 **ES ASÍ DE FÁCIL!** En cuanto lo envíe ya estará instantáneamente **PARTICIPANDO PARA GANAR \$2.500**

SÍGANOS PARA TENER MAS CHANCES DE GANAR

  
@deltachildren

ESCANEE AQUÍ



Para más  
información  
y para ver todos  
nuestros productos

**PARTS: MAKE SURE THAT ALL PRE-ASSEMBLED PARTS ARE TIGHT**  
**PIEZAS: ASEGÚRESE DE QUE TODAS LAS PIEZAS PRE-ENSAMBLADAS ESTÁN BIEN APRETADAS.**

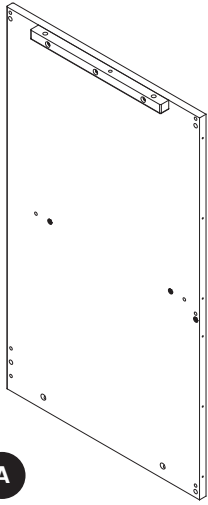

**A**  
 Left Side x 1  
 Lado izquierdo x 1  
 41709

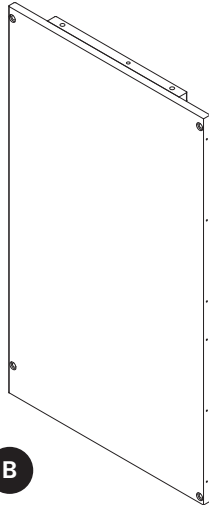

**B**  
 Right Side x 1  
 Lado derecho x 1  
 41710

**C**  
 Back Top Rail x 1  
 Barra trasero superior x 1  
 41239

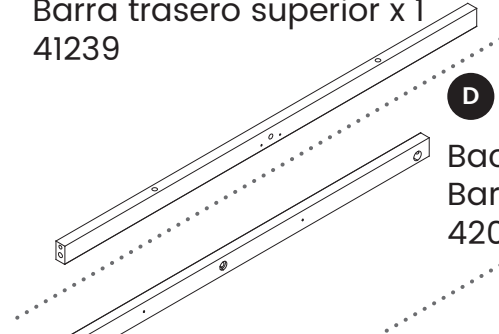

**D**  
 Back Middle Rail x 1  
 Barra trasero medio x 1  
 42051

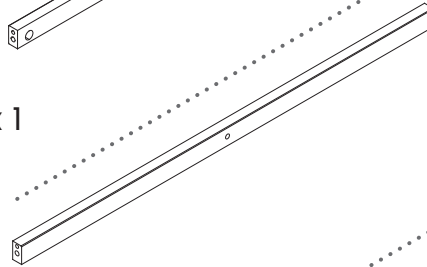

**E**  
 Back Bottom Rail x 1  
 Barra trasero inferior x 1  
 41241

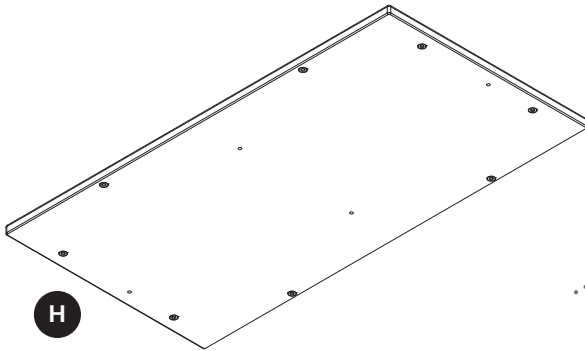

**H**  
 Top Shelf x 1  
 Estante superior x 1  
 29367

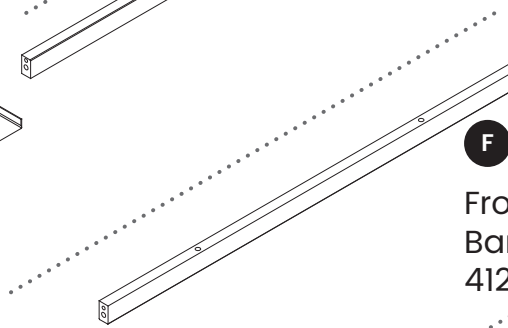

**F**  
 Front Top Rail x 1  
 Barra frontal superior x 1  
 41238

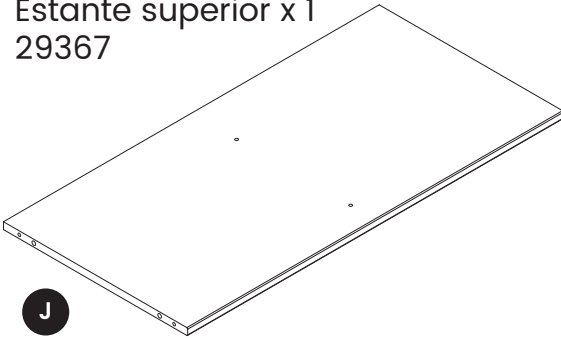

**J**  
 Middle Shelf x 1  
 Estante Medio x 1  
 40679

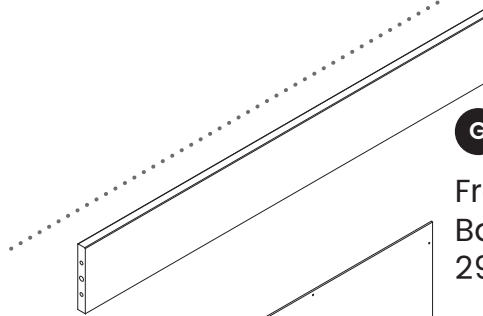

**G**  
 Front Bottom Rail x 1  
 Barra frontal inferior x 1  
 29373

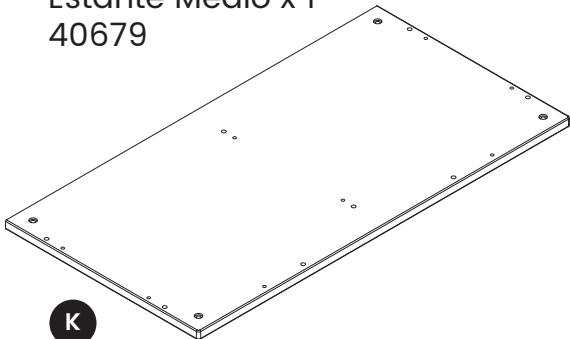

**K**  
 Bottom Shelf x 1  
 Estante inferior x 1  
 41711

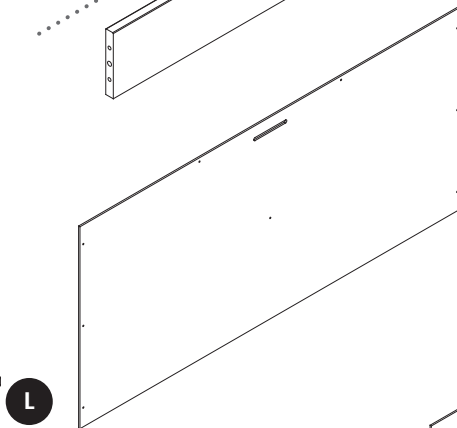

**L**  
 Upper Back Panel x 1  
 Panel Trasero Superior x 1  
 41712

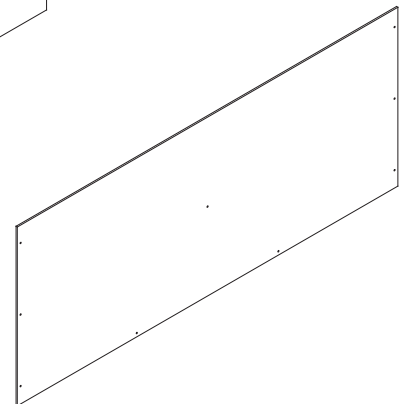

**M**  
 Lower Back Panel x 1  
 Panel Inferior Trasero x 1  
 29378

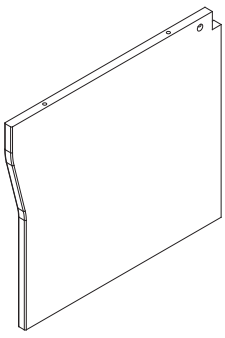

**N**

Top Divider x 1  
Divisor Superior x 1  
29370

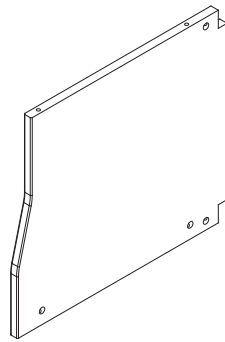

**P**

Bottom Divider x 1  
Divisor Inferior x 1  
29371



**R**

Foot x 4  
Pie x 4  
41713

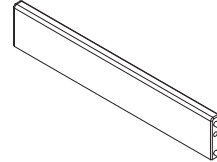

**V**

Changing Top Right side x 1  
Lado derecho del cambiador x 1  
41244

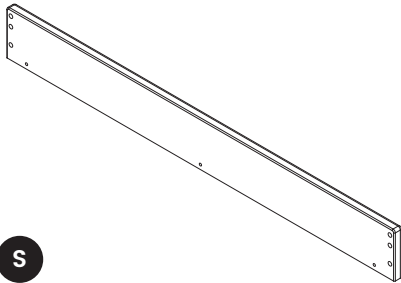

**S**

Changing Top Back x 1  
Parte posterior del cambiador x 1  
40681

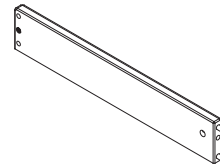

**U**

Changing Top Left Side x 1  
Lado izquierdo del cambiador x 1  
41243

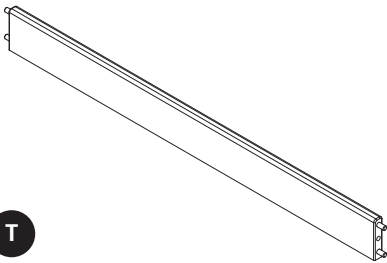

**T**

Changing Top Front x 1  
Parte frontal del cambiador x 1  
40682

4779

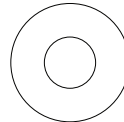

**ZZ1**

Washer x 2  
Arandela x 2

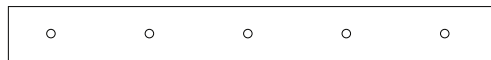

**ZZ2**

Wall Strap x 1  
Abrazadera x 1

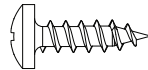

**ZZ3**

Short Screw x 1  
Tornillo corto x 1

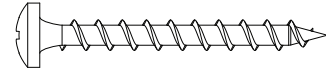

**ZZ4**

Long Screw x 1  
Tornillo Largo x 1

**PARTS: HARDWARE KITS PART#41714**  
**PIEZAS: EL KIT DE HERRAMIENTAS - PIEZA #41714**

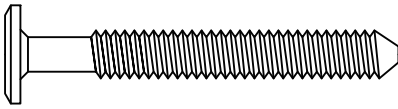
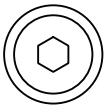

**W** M6 x 50 mm Bolt x 21  
 Perno M6 x 50mm x 21  
 5467

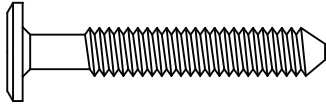
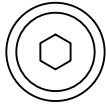

**X** M6 x 40 mm Bolt x 8  
 Perno M6 x 40mm x 8  
 5465

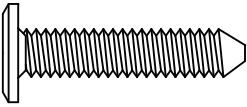
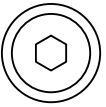

**Y** M6 x 30 mm Bolt x 4  
 Perno M6 x 30mm x 4  
 5463

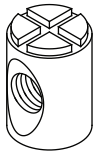

**Z** M6x13mm Barrel Nut x 21  
 Tuerca Cilíndrica M6x13mm x 21  
 5483

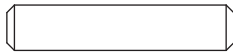

**AA** Φ6x30 mm Wood Dowel x 36  
 Pasador de madera Φ6x30mm x 36  
 4491

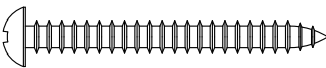
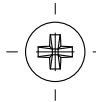

**BB** 40mm Screw x 3  
 Tornillo 40mm x 3  
 5209

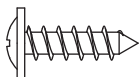

**CC** 15 mm Screw x 20  
 Tornillo de 15 mm x 20  
 5577

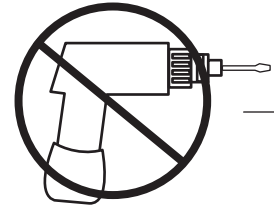

**No drills necessary.**  
 Do not use power screwdriver.

**No hace falta taladrar.**  
 No utilice destornilladores eléctricos

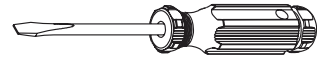

Flat Head Screwdriver (not supplied)  
 Destornillador plano (no suministrado)



Phillips Screwdriver (Not Provided)  
 Destornillador 'Phillips' (No siempre)

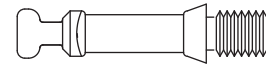

**DD** Cam Bolt x 8  
 Perno de Leva x 8  
 6128

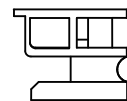
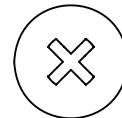

**EE** Cam Lock x 8  
 Bloqueo de Leva x 8  
 6127

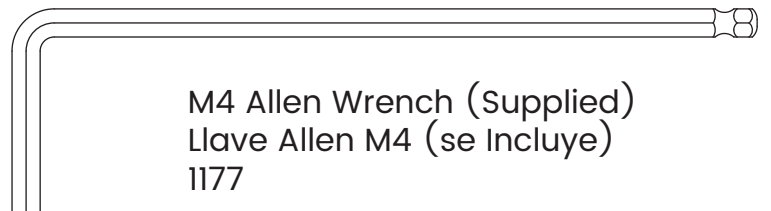

M4 Allen Wrench (Supplied)  
 Llave Allen M4 (se incluye)  
 1177



**How to use the cam lock system.  
Cómo utilizar el sistema de bloqueo de leva.**

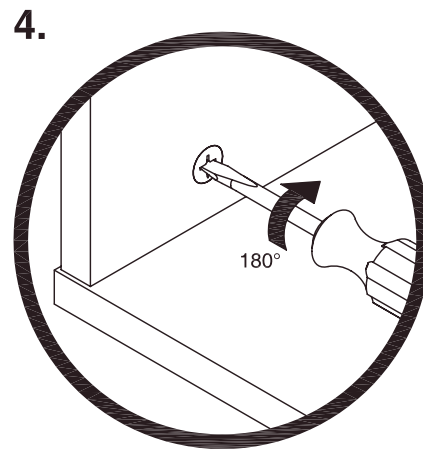
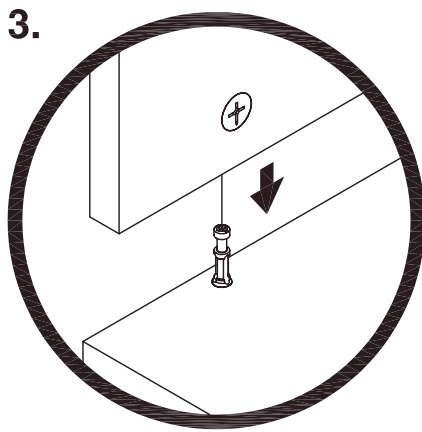
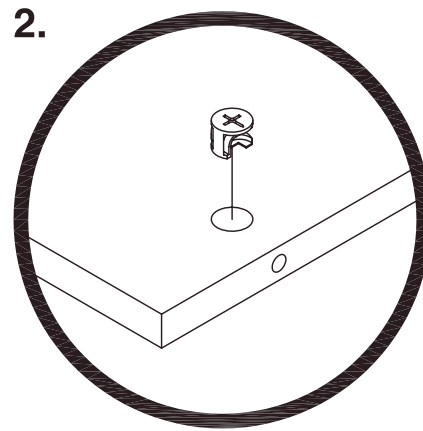
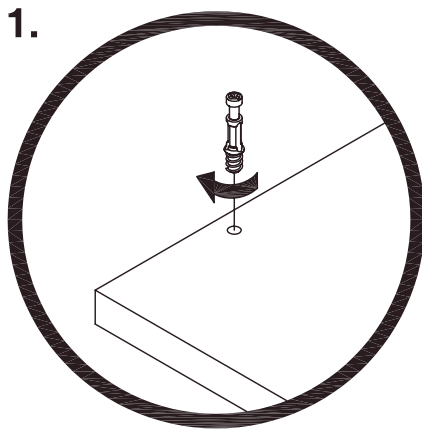

1. Insert the cams.
2. Cam bolts must be screwed down flush.
3. Refer to page 9 for instructions on how to use the cam lock system.

- 
1. Inserte las levas.
  2. Se debe atornillar los pernos de leva.
  3. Refiérase a la página 9 para obtener instrucciones sobre cómo utilizar el sistema de bloqueo de leva.

## CHANGING TABLE ASSEMBLY, STEP 1 ARMADO DEL CAMBIADOR, PASO 1

Parts and tools required to complete step

Piezas y herramientas necesarias para completar este paso

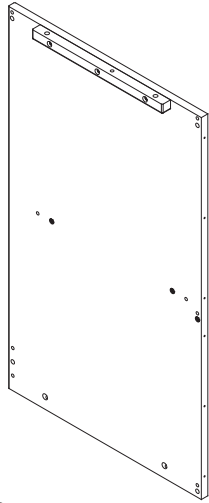

**A**  
Left Side x 1  
Lado izquierdo x 1

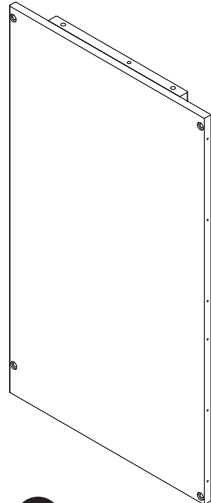

**B**  
Right Side x 1  
Lado derecho x 1



Phillips Screwdriver (Not Provided)  
Destornillador 'Phillips' (No siempre)



**DD** Cam Bolt x 6  
Perno de Leva x 6

1. Cam bolts must be screwed down flush.
2. Refer to page 9 for instructions on how to use the cam lock system.

1. Se debe atornillar los pernos de leva.
2. Refiérase a la página 9 para obtener instrucciones sobre cómo utilizar el sistema de bloqueo de leva.

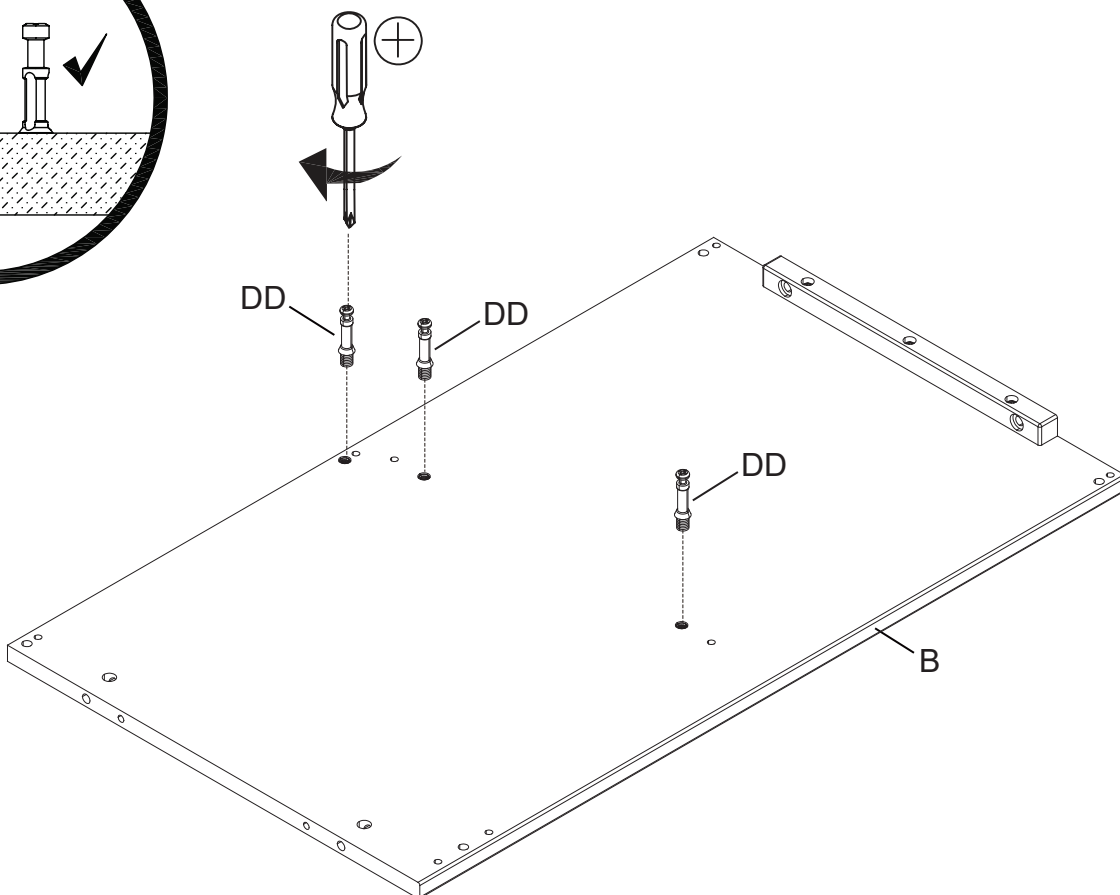
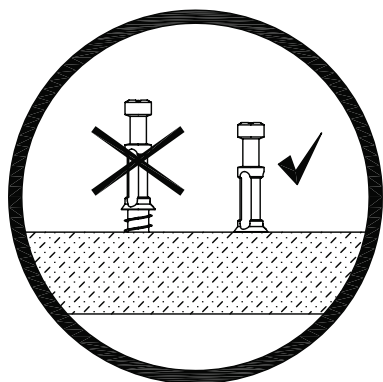
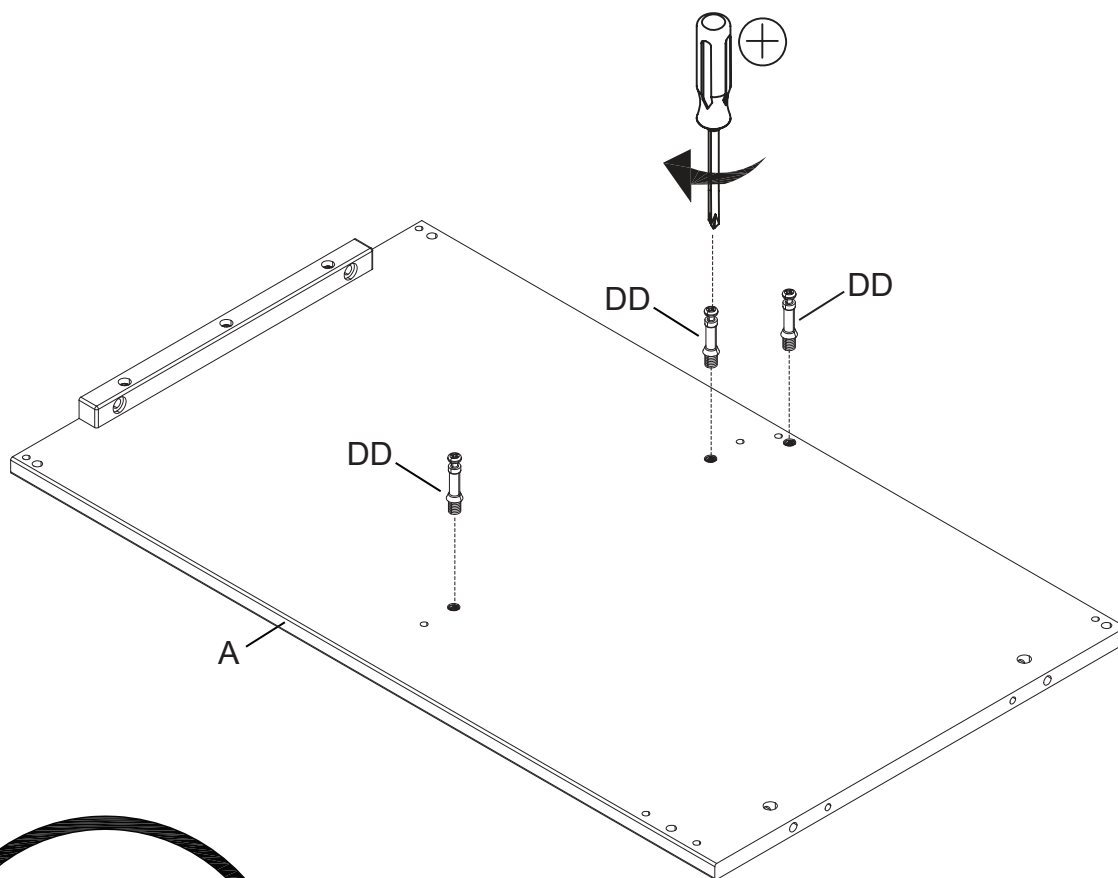

## CHANGING TABLE ASSEMBLY, STEP 2 ARMADO DEL CAMBIADOR, PASO 2

Parts and tools required to complete step

Piezas y herramientas necesarias para completar este paso

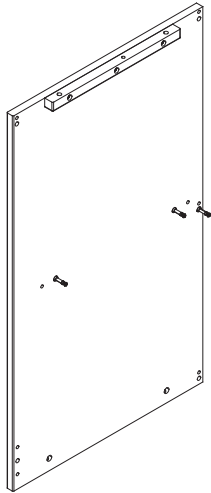

A. Left Side x 1 (From Step 1)  
Lado izquierdo x 1 (Desde el paso 1)

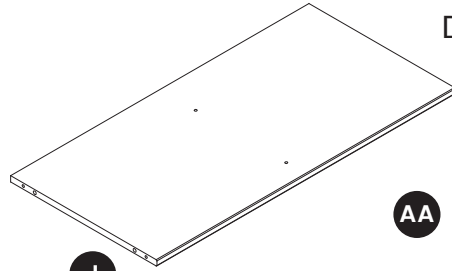

J  
Middle Shelf x 1  
Estante Medio x 1



Phillips Screwdriver (Not Provided)  
Destornillador 'Phillips' (No siempre)

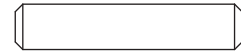

AA  
Φ6x30 mm Wood Dowel x 2  
Pasador de madera Φ6x30mm x 2

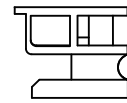
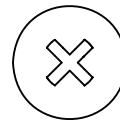

EE  
Cam Lock x 2  
Bloqueo de Leva x 2

Attach the Middle Shelf (Part J) to the Left Side (Part A) with (2) Φ6x30 mm Wood Dowels (Part AA), (2) Cam Bolts (Part DD) and (2) Cam Locks (Part EE). Tighten with the Phillips Screwdriver.

Fije la Estante Medio (Pieza J) al Lado izquierdo (Pieza A) utilizando (2) Pasadores de madera Φ 6x30mm (Pieza AA), (2) Pernos de Levas (Pieza DD) y (2) Bloqueos de Levas (Pieza EE). Apriete todos los pernos utilizando la Destornillador 'Phillips'.

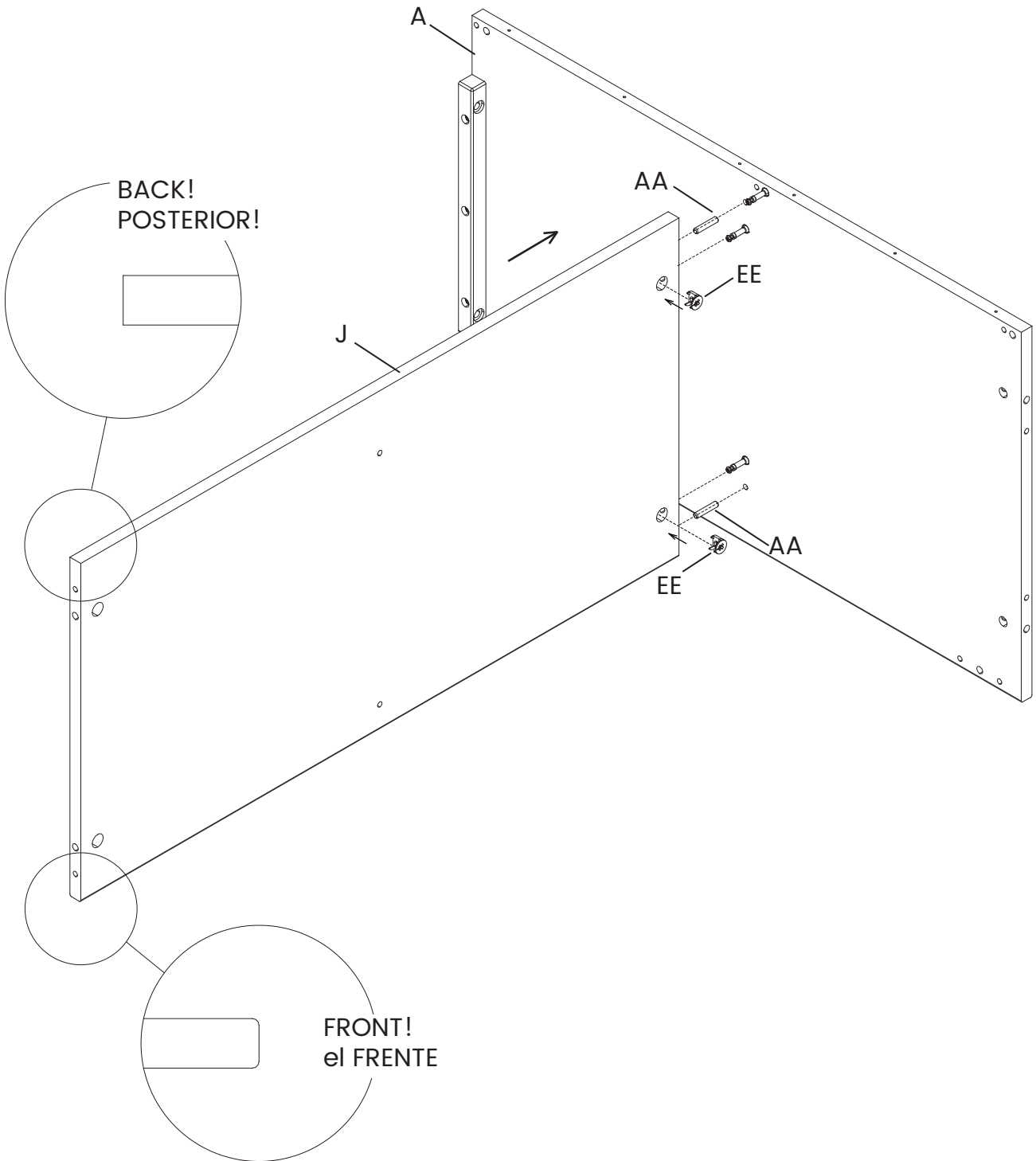

## CHANGING TABLE ASSEMBLY, STEP 3 ARMADO DEL CAMBIADOR, PASO 3

Parts and tools required to complete step

Piezas y herramientas necesarias para completar este paso

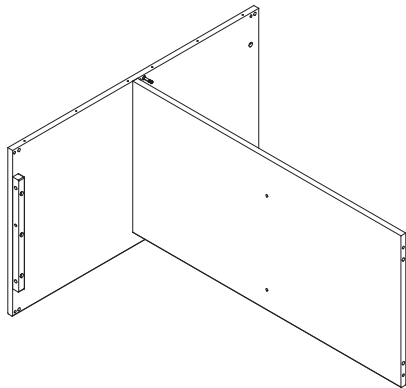

From Step 2  
Desde el paso 2



AA

Φ6x30 mm Wood Dowel x 4  
Pasador de madera Φ6x30mm x 4

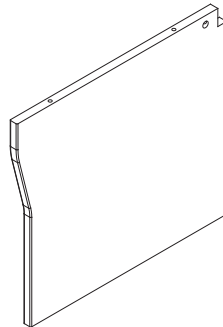

N

Top Divider x 1  
Divisor Superior x 1

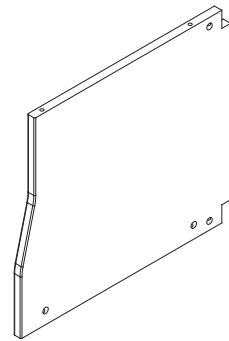

P

Bottom Divider x 1  
Divisor Inferior x 1

Attach the Top Divider (Part N) and the Bottom Divider (Part P) to the Middle Shelf (Part J) using (4) Φ6x30 mm Wood Dowels (Part AA) as shown.

Conecte el divisor superior (Parte N) y el divisor inferior (Parte P) al estante medio (Parte J) utilizando (4) c Pasadores de madera Φ 6x30mm (Pieza AA) como se muestra.

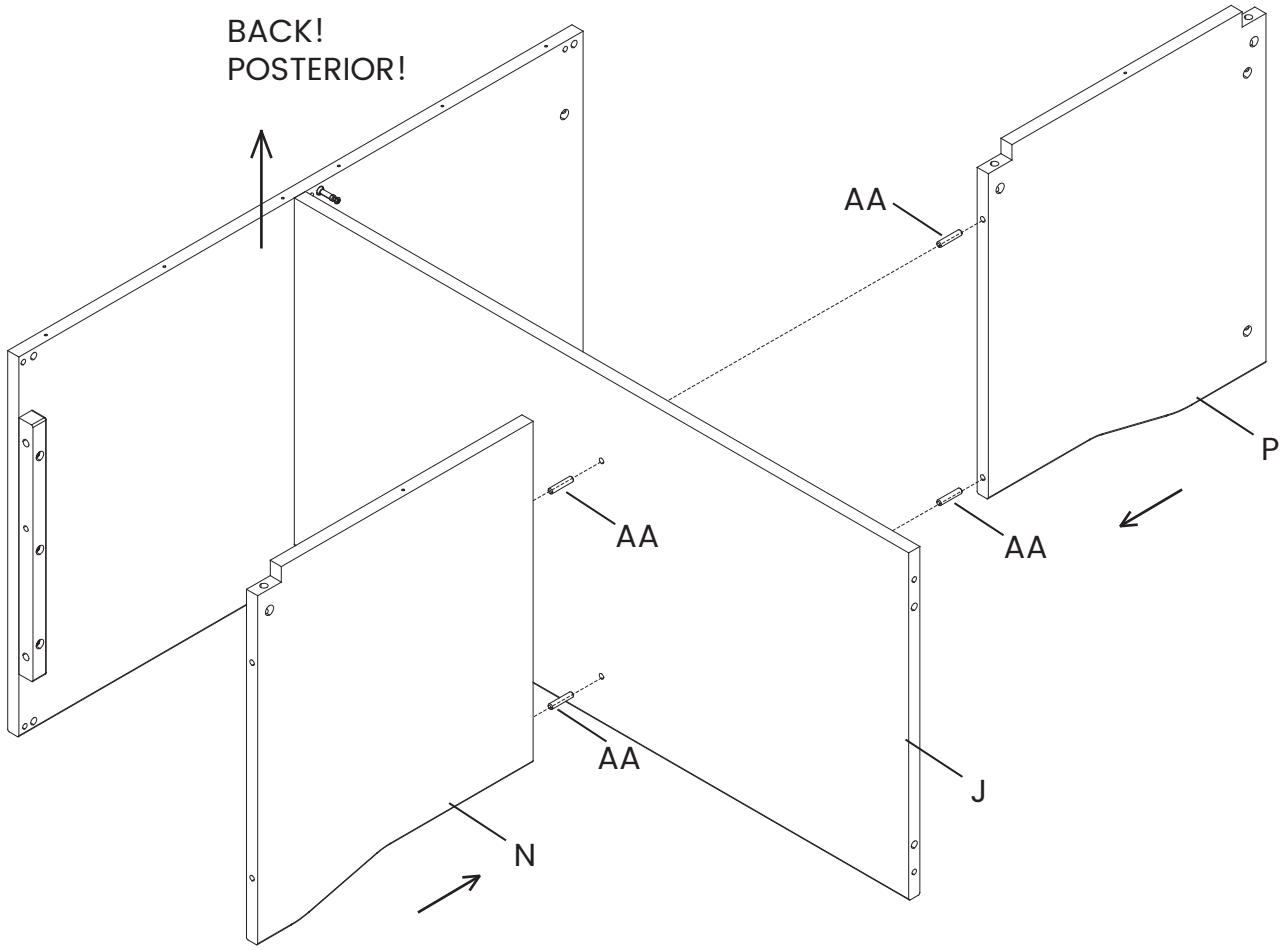

## CHANGING TABLE ASSEMBLY, STEP 4 ARMADO DEL CAMBIADOR, PASO 4

Parts and tools required to complete step

Piezas y herramientas necesarias para completar este paso

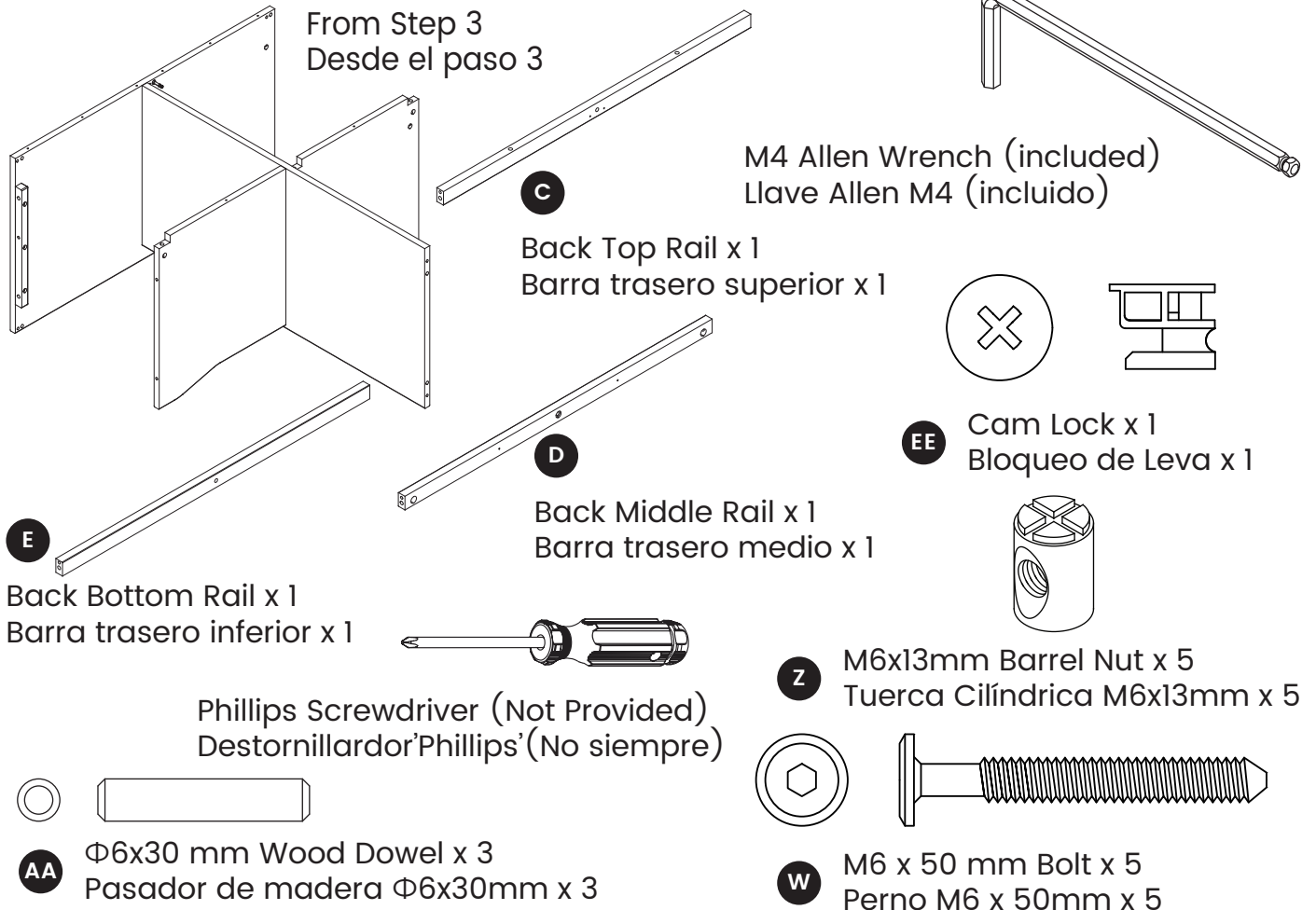

Attach (1) Back Top Rail (Part C), (1) Back Middle Rail (Part D) and (1) Back Bottom Rail (Part E) to the assembly from step 3 with (3) Φ6x30 mm Wood Dowels (Part AA), (1) Cam Lock (Part EE), (5) M6x50mm Bolts (Part W) and (5) M6x13mm Barrel Nuts (Part Z) using the M4 Allen Wrench and Phillips Screwdriver as shown. Use the Flat Head Screwdriver to hold the Barrel Nut in the proper alignment.

Fije (1) Barra trasero superior (Pieza C), (1) Barra trasero medio (Pieza D) y (1) Barra trasero inferior (Pieza E) a la pieza del paso 3 utilizando (3) Pasadores de madera Φ6x30mm (Pieza AA), (1) Bloqueo de Leva (Pieza EE), (5) Pernos M6x50mm (Pieza W) y (5) Tuercas cilíndricas M6x13mm (Pieza Z). Utilice la Llave Allen M4 y Destornillador 'Phillips' para el proceso de apriete. Utilice el Destornillador de Paleta para mantener la Tuerca Cilíndrica alineado correctamente.



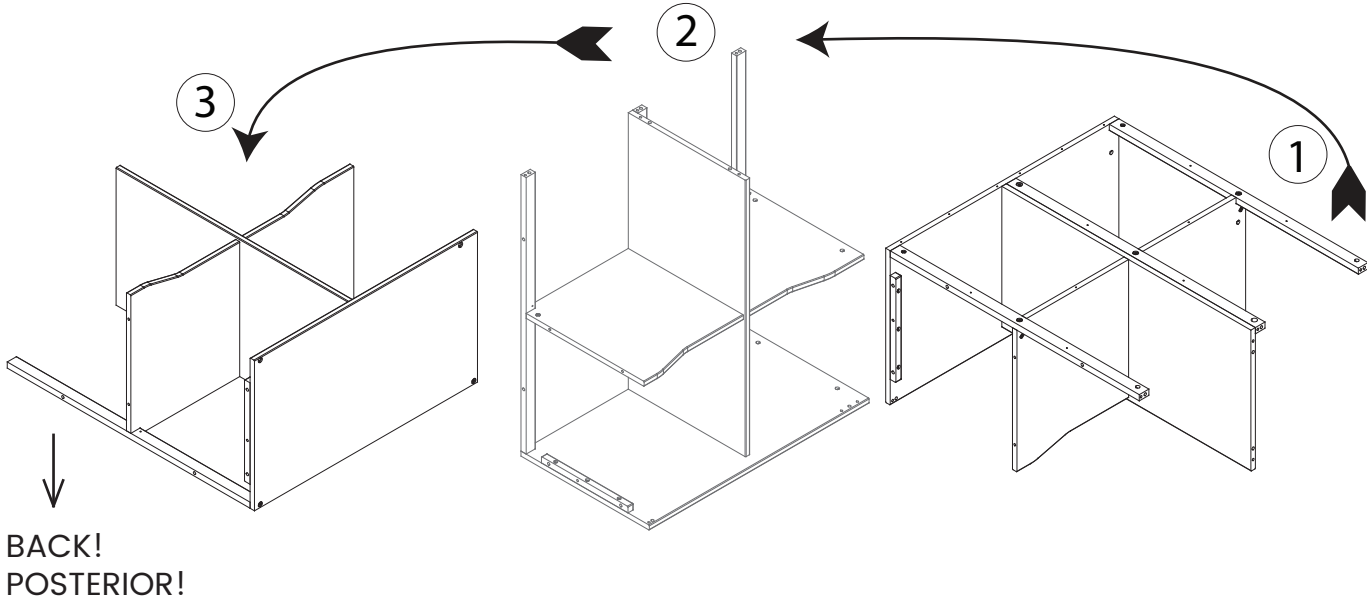
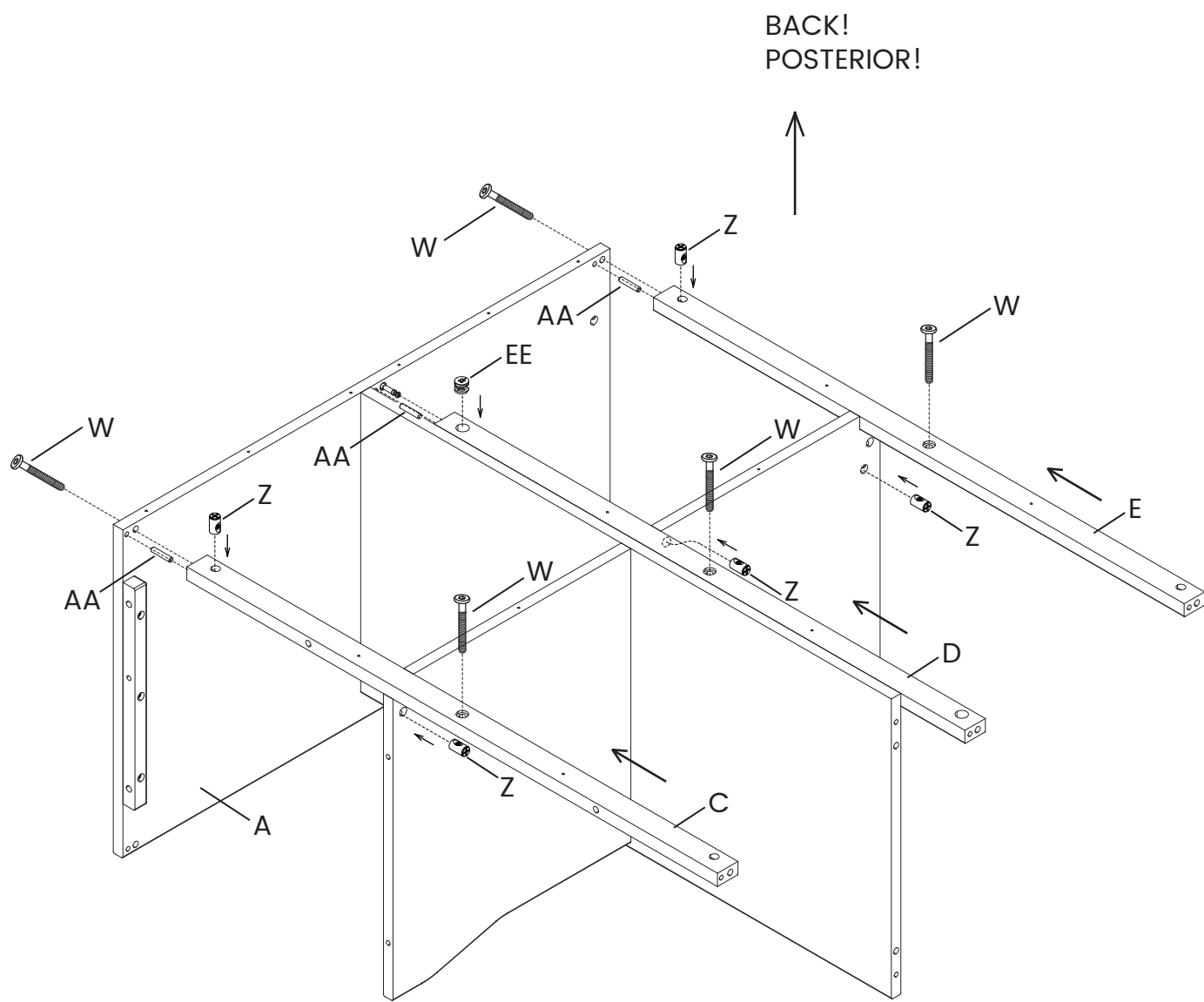

## CHANGING TABLE ASSEMBLY, STEP 5 ARMADO DEL CAMBIADOR, PASO 5

Parts and tools required to complete step

Piezas y herramientas necesarias para completar este paso

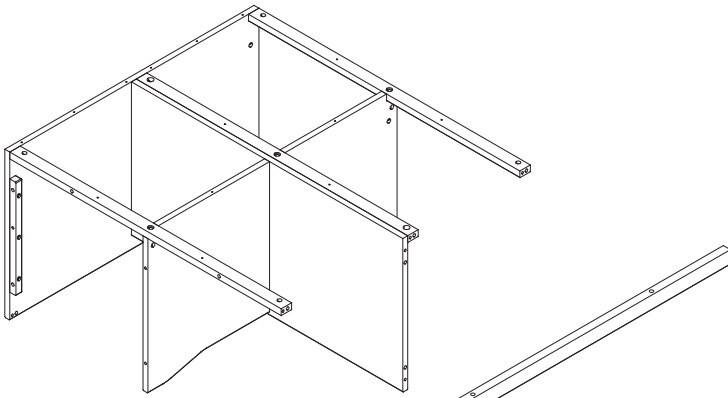

From Step 4  
Desde el paso 4

**F**

Front Top Rail x 1  
Barra frontal superior x 1

**G**

Front Bottom Rail x 1  
Barra frontal inferior x 1



M4 Allen Wrench (included)  
Llave Allen M4 (incluido)



**Z**

M6x13mm Barrel Nut x 2  
Tuerca Cilíndrica M6x13mm x 2

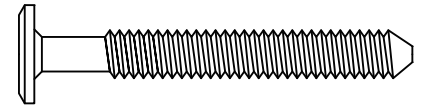
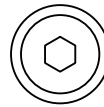

**W**

M6 x 50 mm Bolt x 2  
Perno M6 x 50mm x 2



**AA**

Φ6x30 mm Wood Dowel x 3  
Pasador de madera Φ6x30mm x 3

Attach (1) Front Top Rail (Part F) and (1) Front Bottom Rail (Part G) to the assembly from step 4 with (3) Φ6x30 mm Wood Dowels (Part AA), (2) M6x50mm Bolts (Part W) and (2) M6x13mm Barrel Nuts (Part Z) using the M4 Allen Wrench as shown. Use the Flat Head Screwdriver to hold the Barrel Nut in the proper alignment.

Fije (1) Barra frontal superior (Pieza F) y (1) Barra frontal inferior (Pieza G) a la pieza del paso 4 utilizando (3) Pasadores de madera Φ6x30mm (Pieza AA), (2) Pernos M6x50mm (Pieza W) y (2) Tuercas cilíndricas M6x13mm (Pieza Z). Utilice la Llave Allen M4 para el proceso de apriete. Utilice el Destornillador de Paleta para mantener la Tuerca Cilíndrica alineado correctamente.

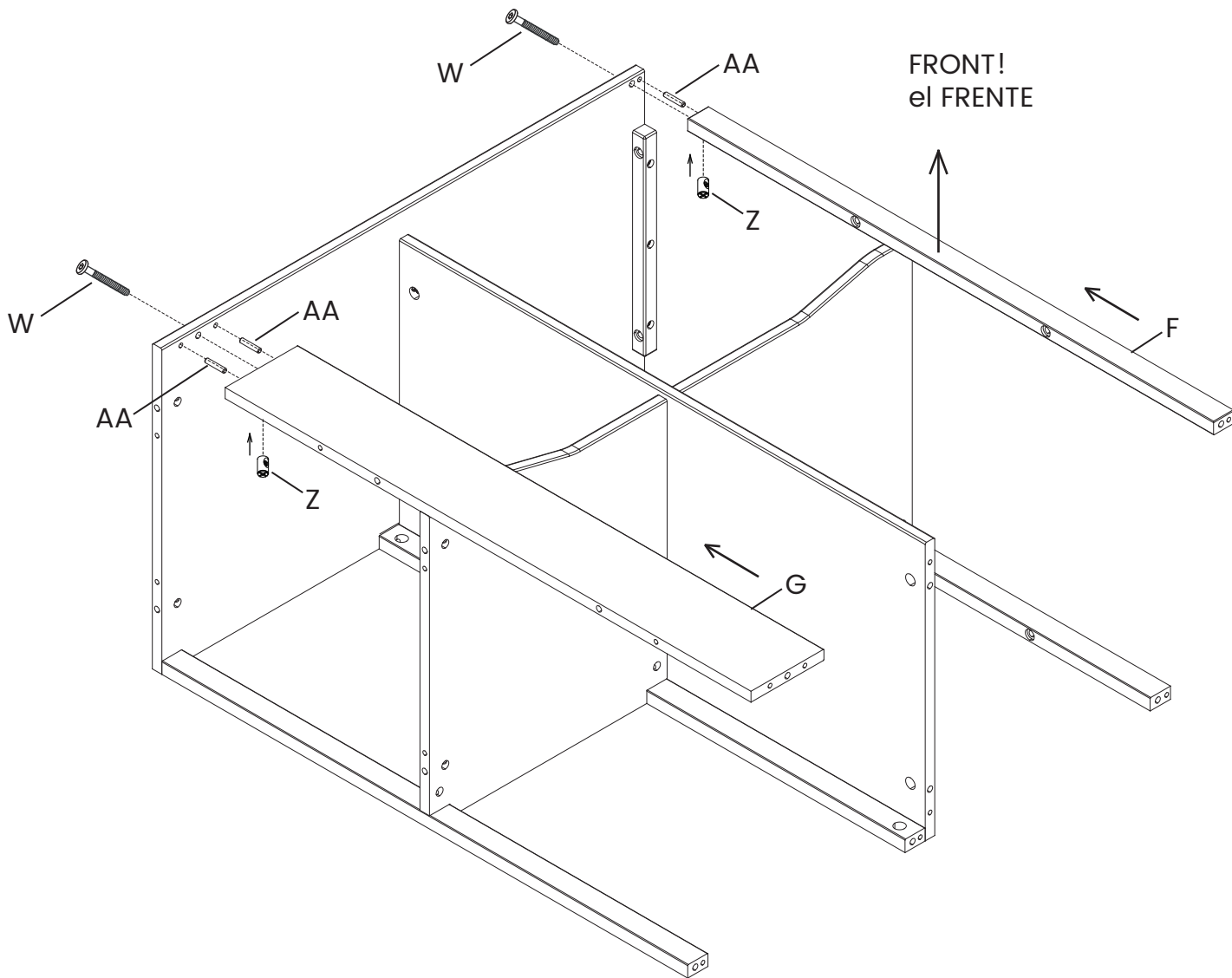

FRONT!  
el FRENTE

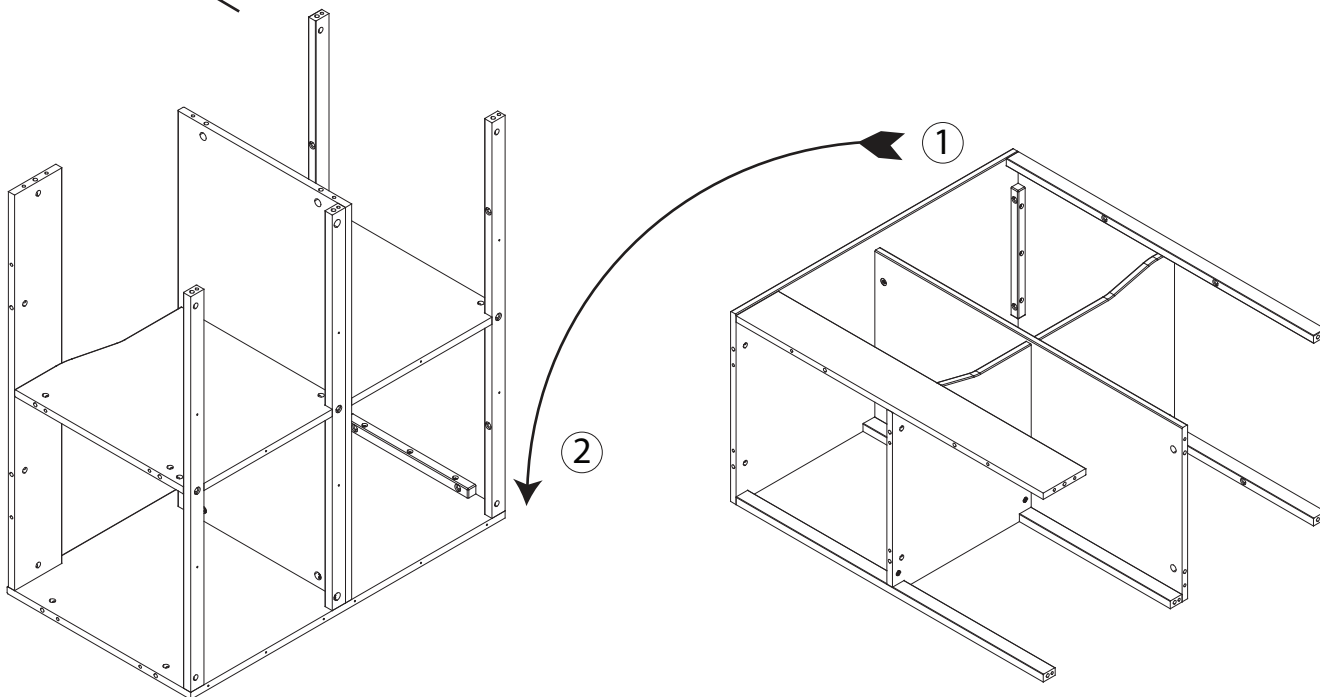

## CHANGING TABLE ASSEMBLY, STEP 6 ARMADO DEL CAMBIADOR, PASO 6

Parts and tools required to complete step

Piezas y herramientas necesarias para completar este paso

From Step 5  
Desde el paso 5

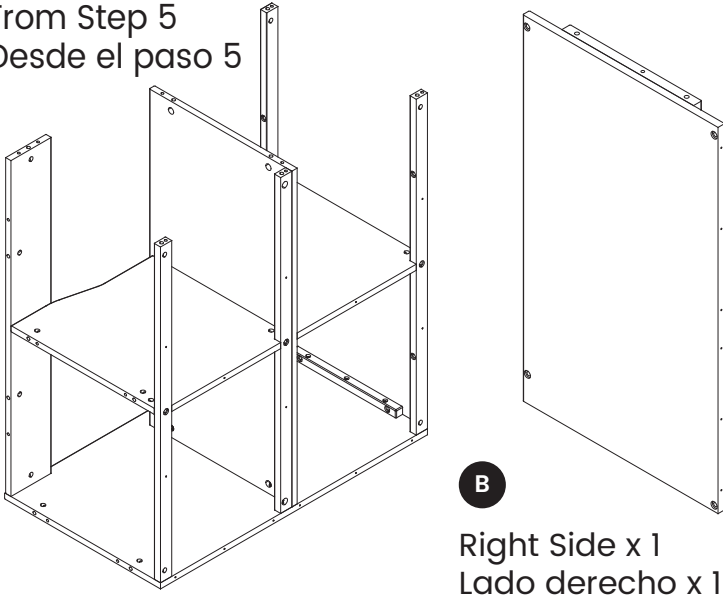

**B**  
Right Side x 1  
Lado derecho x 1

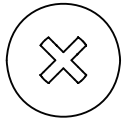

**EE** Cam Lock x 1  
Bloqueo de Leva x 1

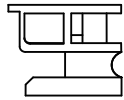

Phillips Screwdriver (Not Provided)  
Destornillador 'Phillips' (No siempre)

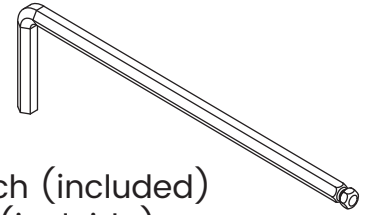

M4 Allen Wrench (included)  
Llave Allen M4 (incluido)



**Z** M6x13mm Barrel Nut x 4  
Tuerca Cilíndrica M6x13mm x 4

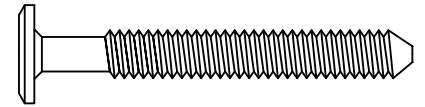
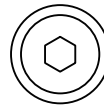

**W** M6 x 50 mm Bolt x 4  
Perno M6 x 50mm x 4



**AA** Φ6x30 mm Wood Dowel x 8  
Pasador de madera Φ6x30mm x 8

Attach the Right Side (Part B) to the assembly from step 5 with (8) Φ6x30 mm Wood Dowels (Part AA), (1) Cam Locks (Part EE), (4) M6x50mm Bolts (Part W) and (4) M6x13mm Barrel Nuts (Part Z) using the M4 Allen Wrench and Phillips Screwdriver as shown. Use the Flat Head Screwdriver to hold the Barrel Nut in the proper alignment.

Fije la Lado derecho (Pieza B) a la pieza del paso 5 utilizando (8) Pasadores de madera Φ6x30mm (Pieza AA), (1) Bloqueos de Levas (Pieza EE), (4) Pernos M6x50mm (Pieza W) y (4) Tuercas cilíndricas M6x13mm (Pieza Z). Utilice la Llave Allen M4 y Destornillador 'Phillips' para el proceso de apriete. Utilice el Destornillador de Paleta para mantener la Tuerca Cilíndrica alineado correctamente.

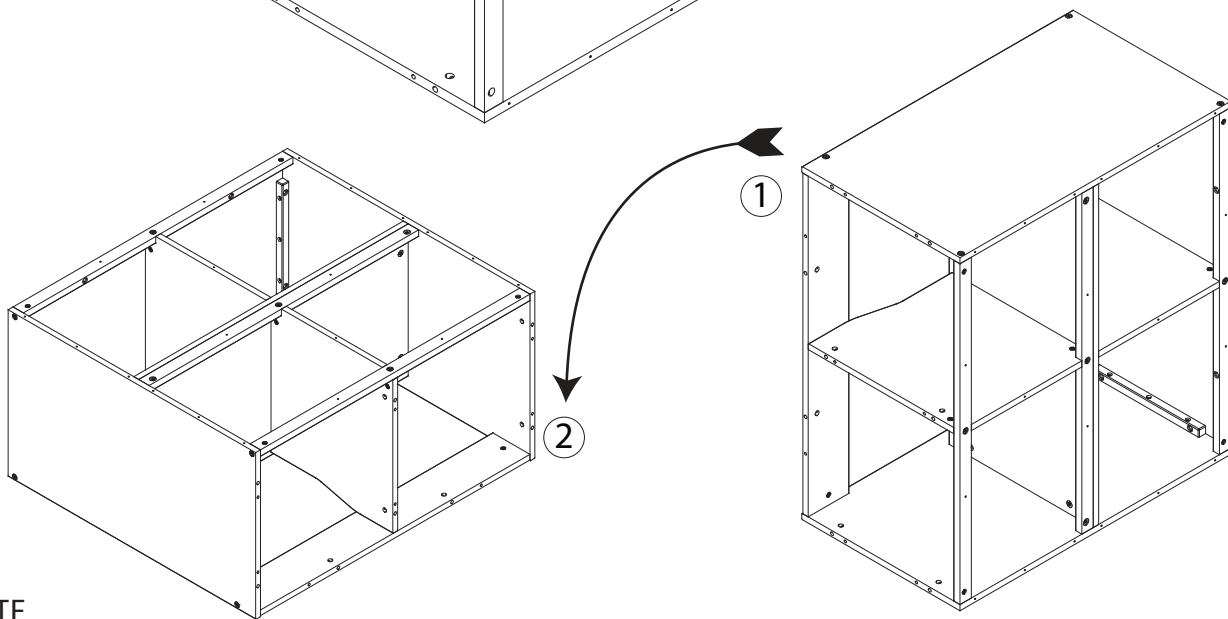
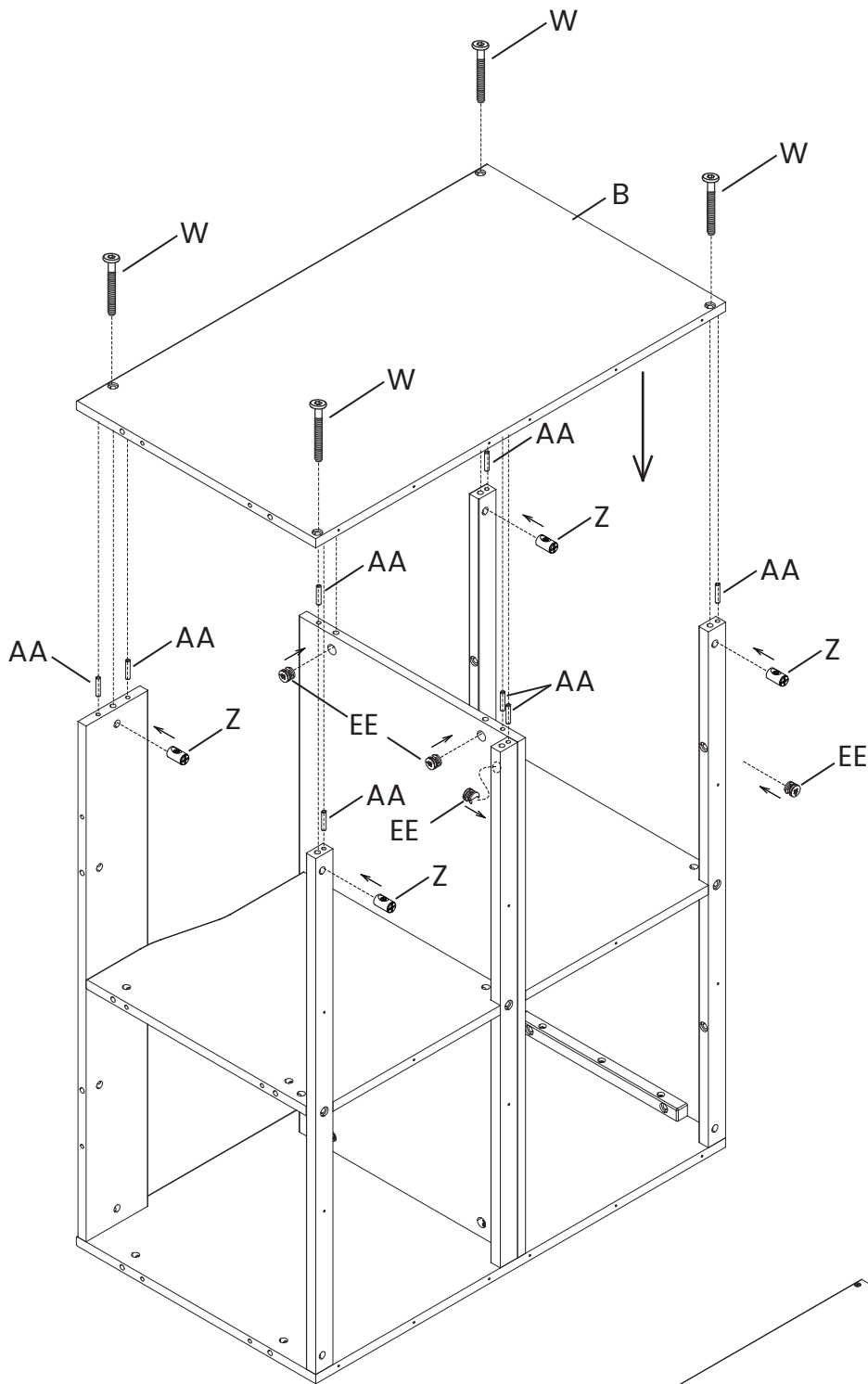

FRONT!  
el FRENTE

## CHANGING TABLE ASSEMBLY, STEP 7 ARMADO DEL CAMBIADOR, PASO 7

Parts and tools required to complete step

Piezas y herramientas necesarias para completar este paso

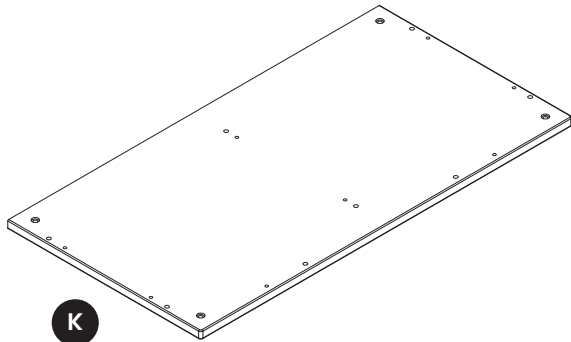

**K**

Bottom Shelf x 1  
Estante inferior x 1

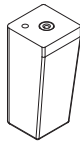

**R**

Foot x 4  
Pie x 4

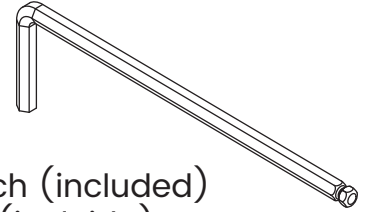

M4 Allen Wrench (included)  
Llave Allen M4 (incluido)

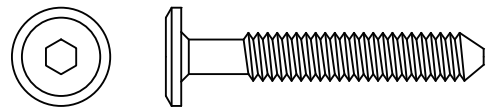

**X**

M6 x 40 mm Bolt x 4  
Perno M6 x 40mm x 4

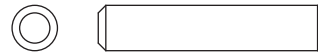

**AA**

Φ6x30 mm Wood Dowel x 4  
Pasador de madera Φ6x30mm x 4

Attach (4) feet (Part R) to the bottom of the Bottom Shelf (Part K) with (4) Φ 6x30 mm Wood Dowels (Part AA) and (4) M6x40mm Bolts (Part X) using the M4 Allen Wrench as shown.

Fije (4) pies (Pieza R) a la estante inferior (Pieza K) utilizando (4) Pasadores de madera Φ6x30mm (Pieza AA) y (4) Pernos M6x40mm (Pieza X). Utilice la Llave Allen M4 para el proceso de apriete.

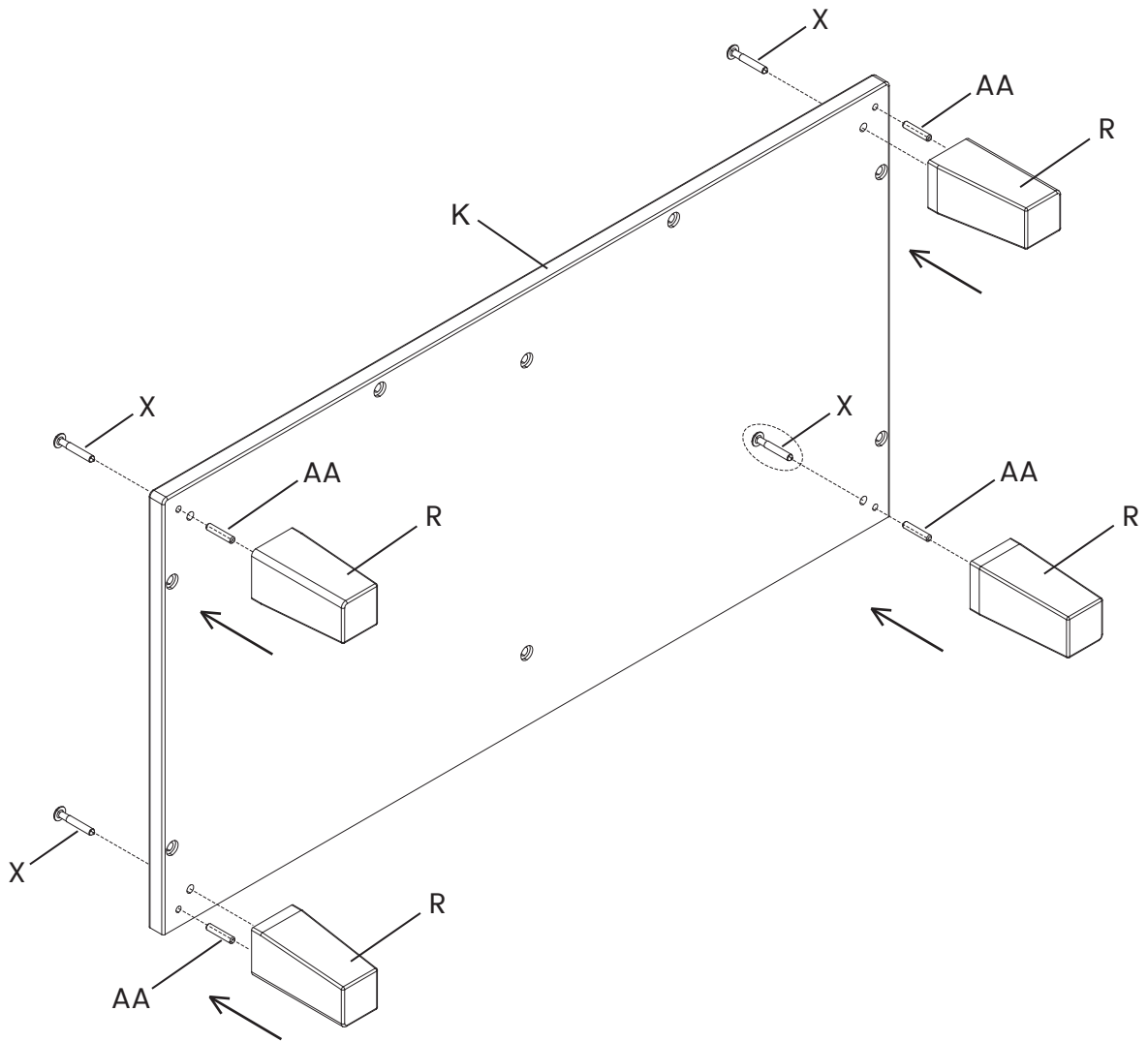

## CHANGING TABLE ASSEMBLY, STEP 8 ARMADO DEL CAMBIADOR, PASO 8

Parts and tools required to complete step

Piezas y herramientas necesarias para completar este paso

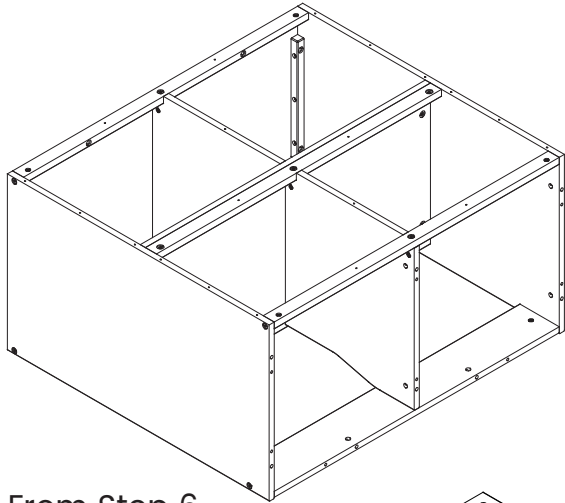

From Step 6  
Desde el paso 6

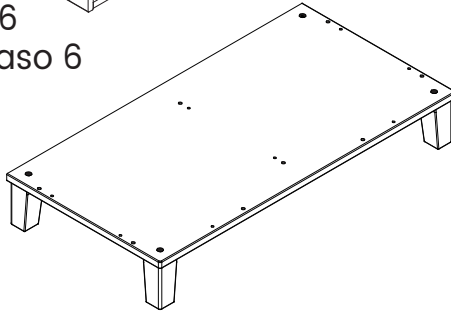

**K**

Bottom Shelf x 1 (From Step 7)  
Estante inferior x 1 (Desde el paso 7)

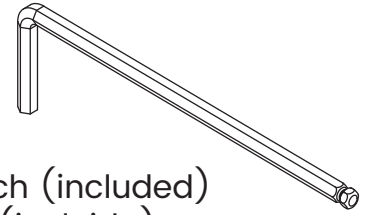

M4 Allen Wrench (included)  
Llave Allen M4 (incluido)



**Z** M6x13mm Barrel Nut x 8  
Tuerca Cilíndrica M6x13mm x 8

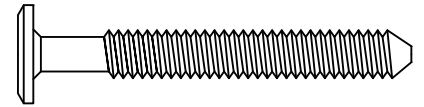
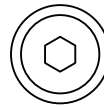

**W** M6 x 50 mm Bolt x 8  
Perno M6 x 50mm x 8



**AA** Φ6x30 mm Wood Dowel x 8  
Pasador de madera Φ6x30mm x 8

Attach the Bottom Shelf (Part K) to the assembly from step 6 with (8) Φ6x30 mm Wood Dowels (Part AA), (8) M6x50mm Bolts (Part W) and (8) M6x13mm Barrel Nuts (Part Z) using the M4 Allen Wrench as shown. Use the Flat Head Screwdriver to hold the Barrel Nut in the proper alignment.

Fije la Estante inferior (Pieza K) a la pieza del paso 6 utilizando (8) Pasadores de madera Φ6x30mm (Pieza AA), (8) Pernos M6x50mm (Pieza W) y (8) Tuercas cilíndricas M6x13mm (Pieza Z). Utilice la Llave Allen M4 para el proceso de apriete. Utilice el Destornillador de Paleta para mantener la Tuerca Cilíndrica alineado correctamente.



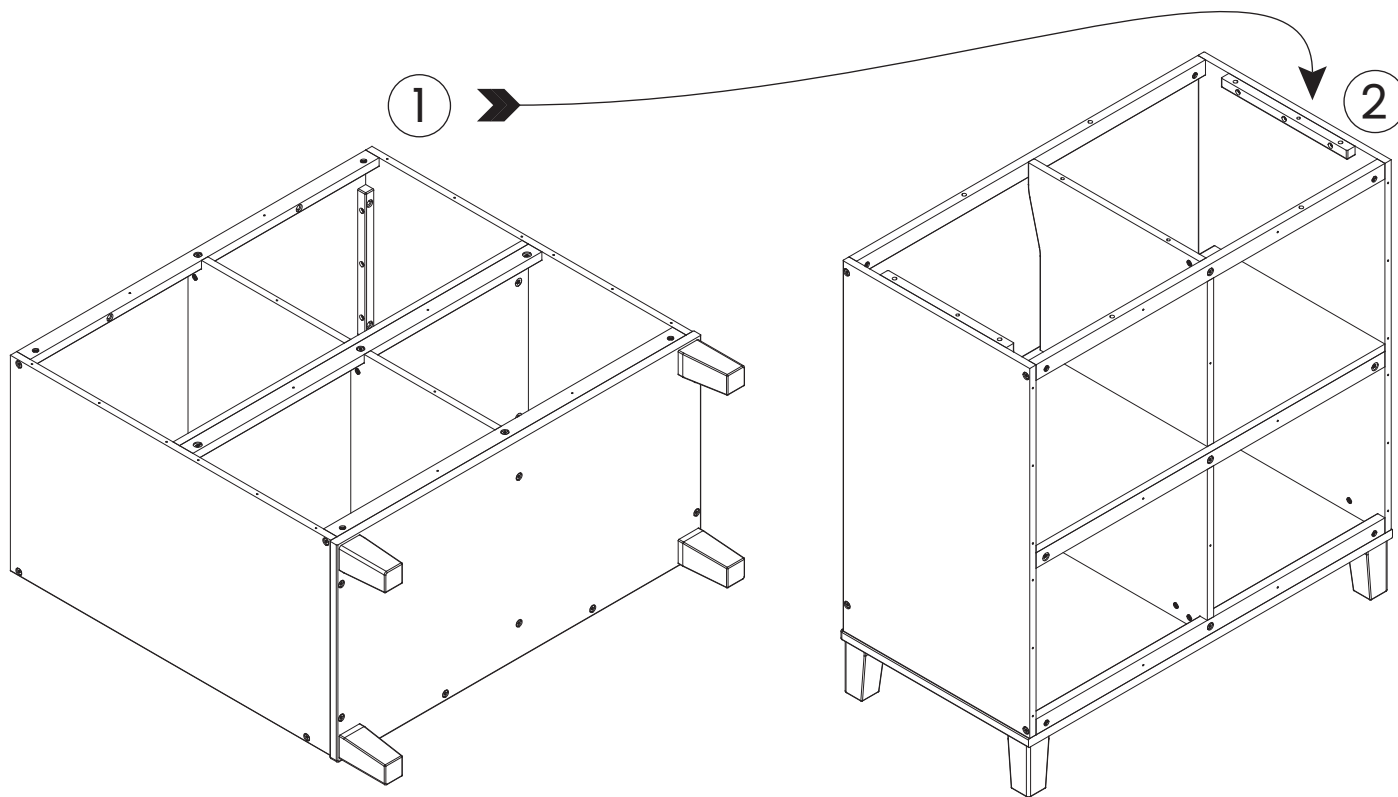
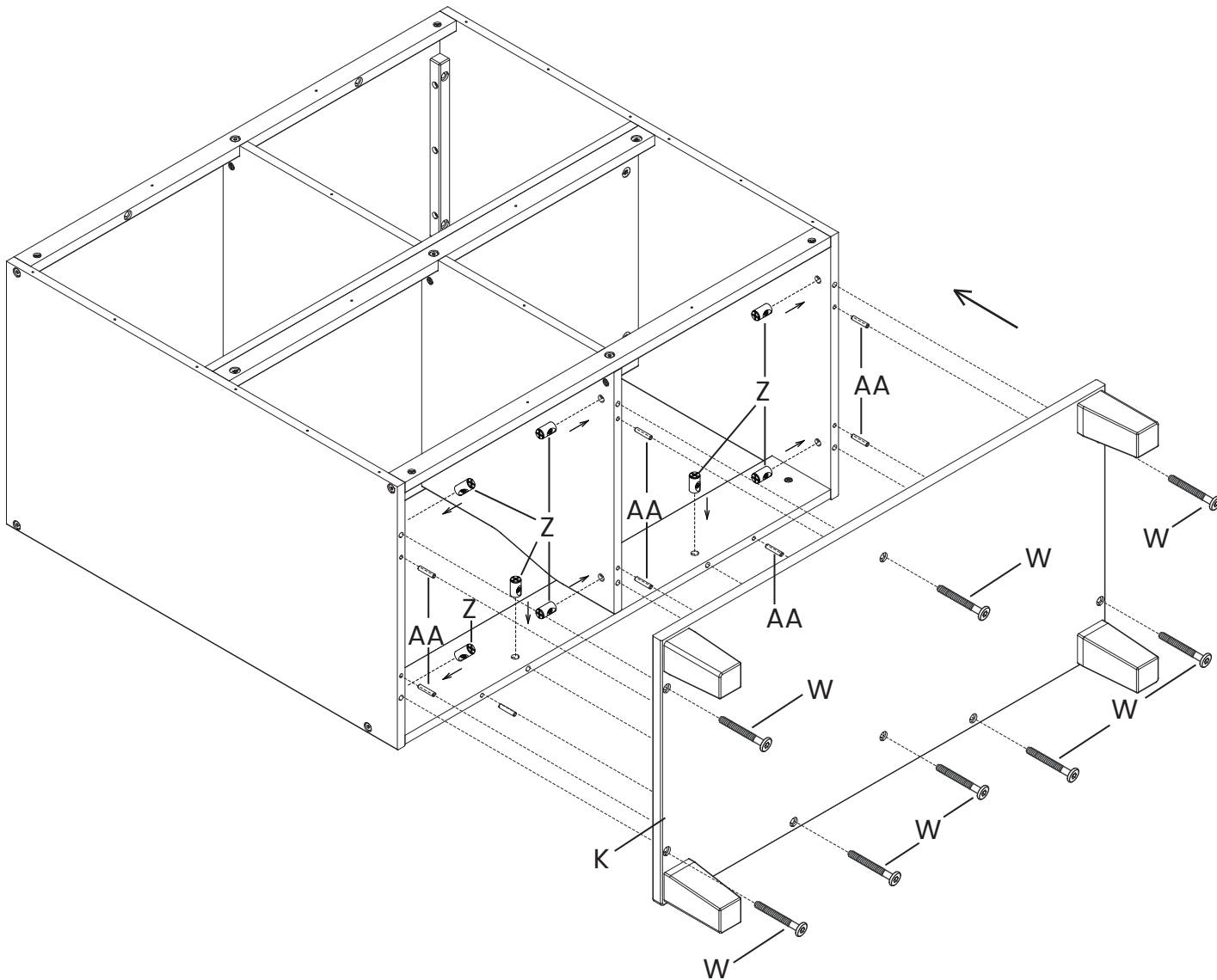

## CHANGING TABLE ASSEMBLY, STEP 9 ARMADO DEL CAMBIADOR, PASO 9

Parts and tools required to complete step

Piezas y herramientas necesarias para completar este paso

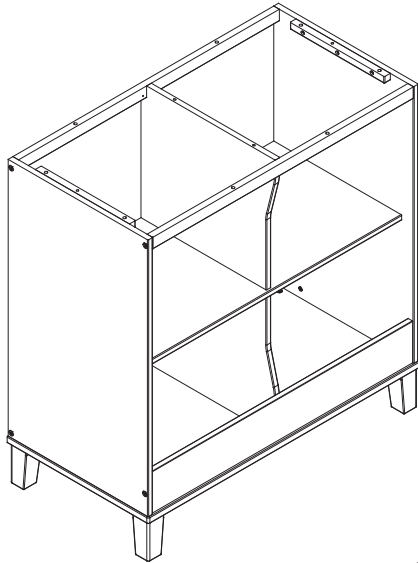

From Step 8  
Desde el paso 8

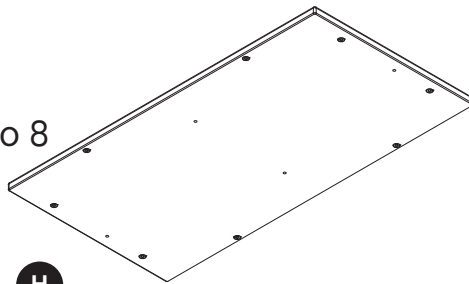

**H**

Top Shelf x 1  
Estante superior x 1

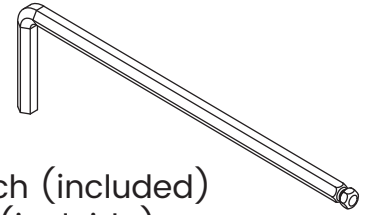

M4 Allen Wrench (included)  
Llave Allen M4 (incluido)



**AA**

Φ6x30 mm Wood Dowel x 4  
Pasador de madera Φ6x30mm x 4

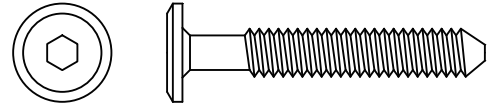

**X**

M6 x 40 mm Bolt x 4  
Perno M6 x 40mm x 4

Attach the Top Shelf (Part H) to the assembly from step 8 with (4) Φ6x30 mm Wood Dowels (Part AA) and (4) M6x40mm Bolts (Part X) using the M4 Allen Wrench as shown.

Fije la Estante superior (Pieza H) a la pieza del paso 8 utilizando (4) Pasadores de madera Φ6x30mm (Pieza AA) y (4) Pernos M6x40mm (Pieza X). Utilice la Llave Allen M4 para el proceso de apriete.

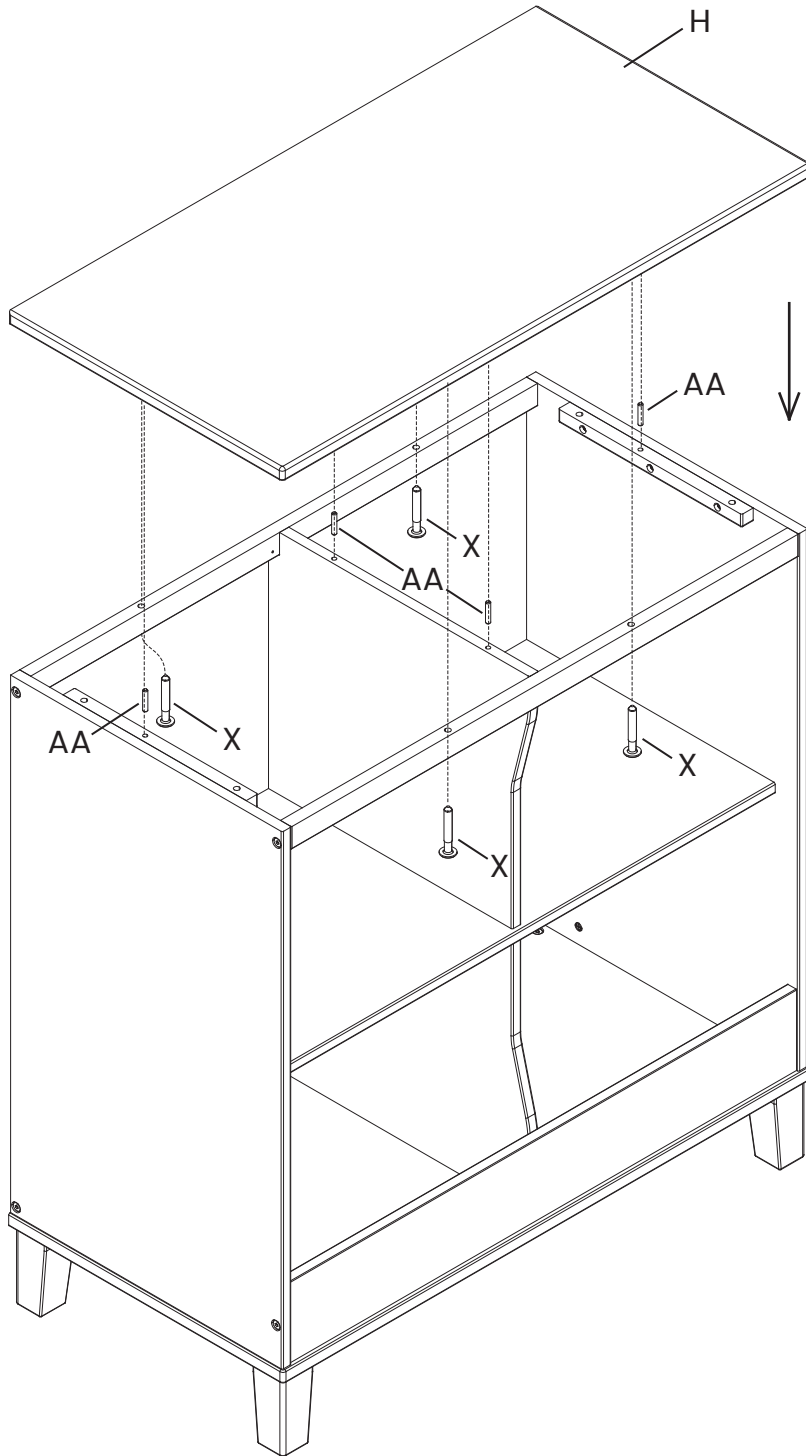

## CHANGING TABLE ASSEMBLY, STEP 10 ARMADO DEL CAMBIADOR, PASO 10

Parts and tools required to complete step

Piezas y herramientas necesarias para completar este paso

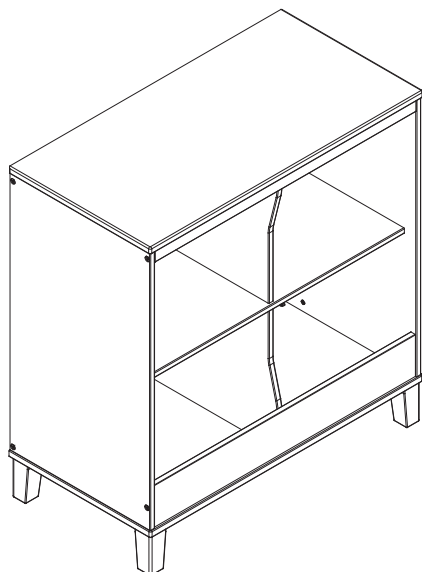

From Step 9  
Desde el paso 9

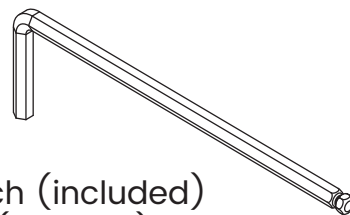

M4 Allen Wrench (included)  
Llave Allen M4 (incluido)

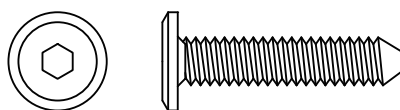

**Y** M6 x 30 mm Bolt x 4  
Perno M6 x 30mm x 4

Attach the Top Shelf (Part H) to the assembly from step 9 with (4) M6x30mm Bolts (Part Y) using the M4 Allen Wrench as shown.

Fije la Estante superior (Pieza H) a la pieza del paso 9 utilizando (4) Pernos M6x30mm (Pieza Y). Utilice la Llave Allen M4 para el proceso de apriete.

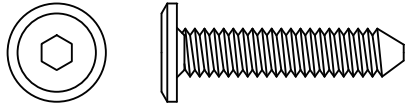

**Y** M6 x 30 mm Bolt x 4  
Perno M6 x 30mm x 4

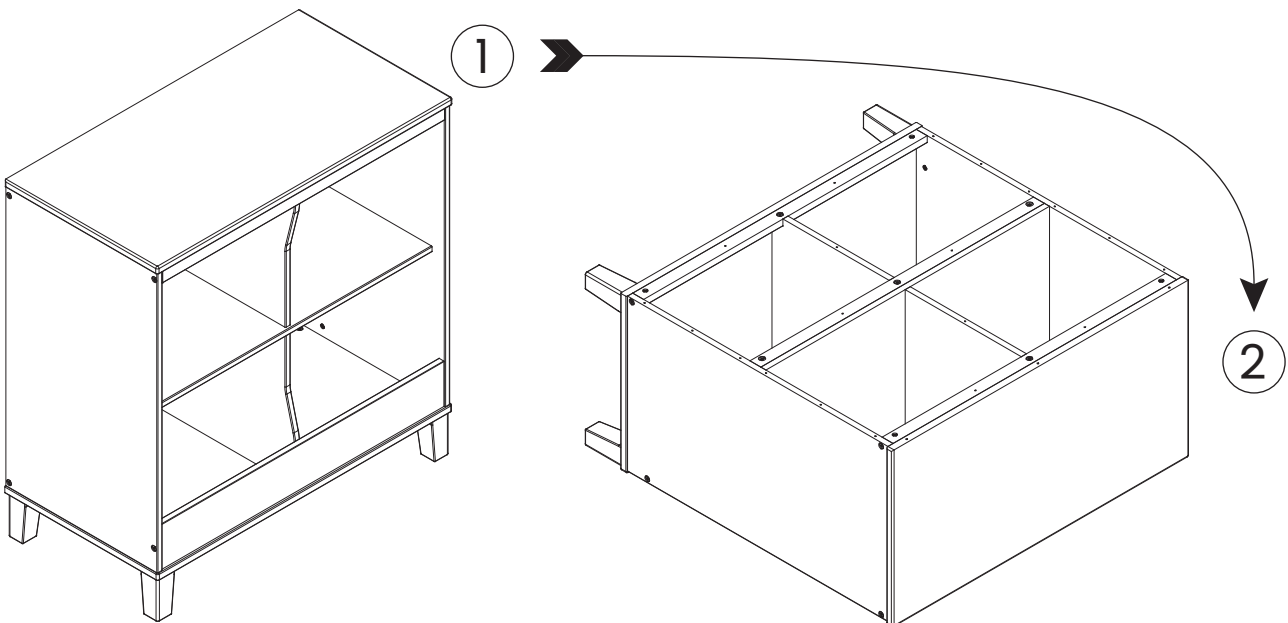
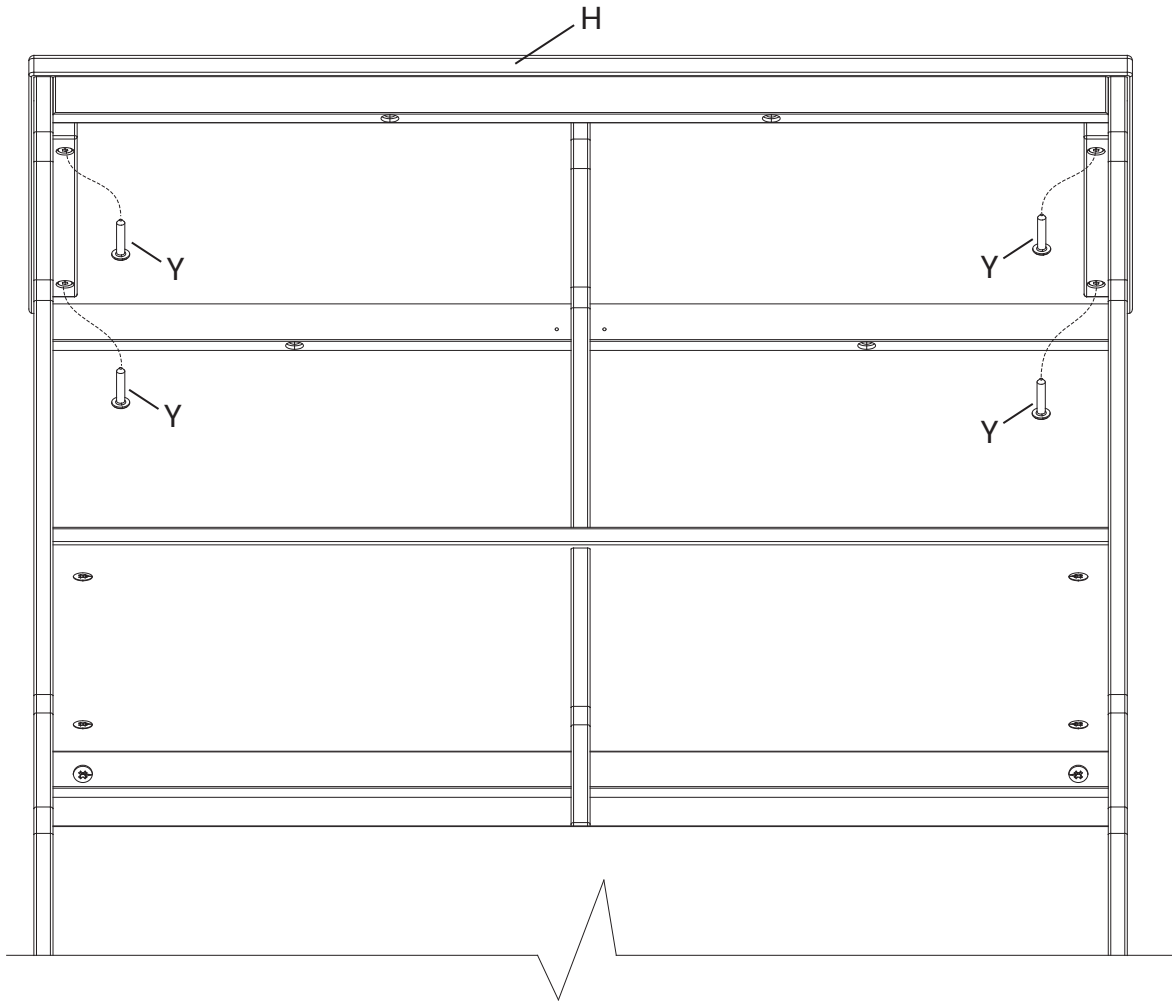

## CHANGING TABLE ASSEMBLY, STEP 11 ARMADO DEL CAMBIADOR, PASO 11

Parts and tools required to complete step

Piezas y herramientas necesarias para completar este paso

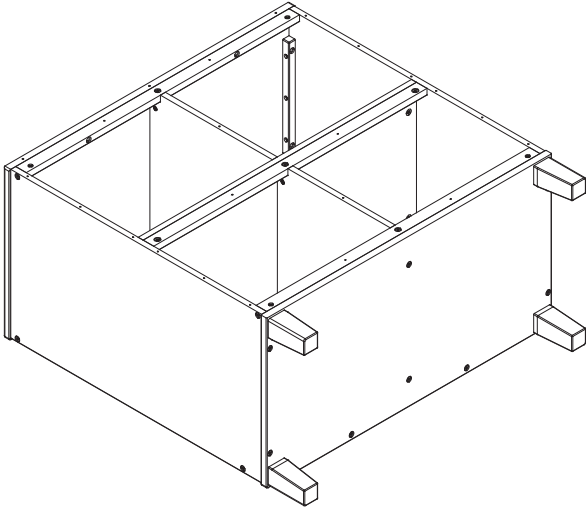

From Step 10  
Desde el paso 10

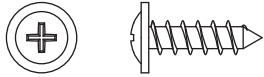

**CC** 15 mm Screw x 20  
Tornillo de 15 mm x 20

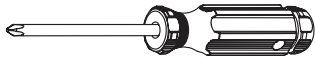

Phillips Screwdriver (Not Provided)  
Destornillador 'Phillips' (No siempre)

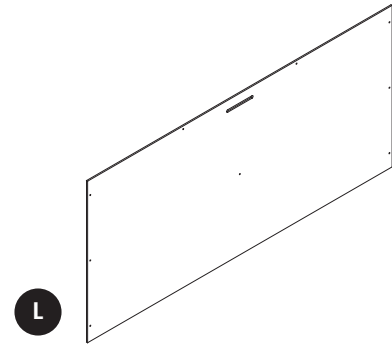

**L**  
Upper Back Panel x 1  
Panel Trasero Superior x 1

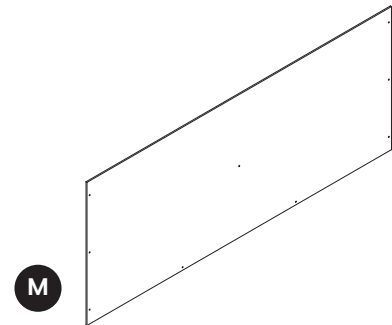

**M**  
Lower Back Panel x 1  
Panel Inferior Trasero x 1

Attach (1) Upper Back Panel (Part L) and (1) Lower Back Panel (Part M) to the assembly from step 10 using (20) 15 mm Screws (Part CC). Tighten with the Phillips Screwdriver. Ensure the Address Label is facing to the back of the unit.

Fije el panel posterior superior (Pieza L) y el panel posterior inferior (Pieza M) al conjunto de piezas del Paso 10 utilizando (20) tornillos 15mm (Pieza CC). Apriete utilizando un destornillador Phillips. Asegúrese de que la etiqueta de dirección enfrente la parte posterior de la unidad.

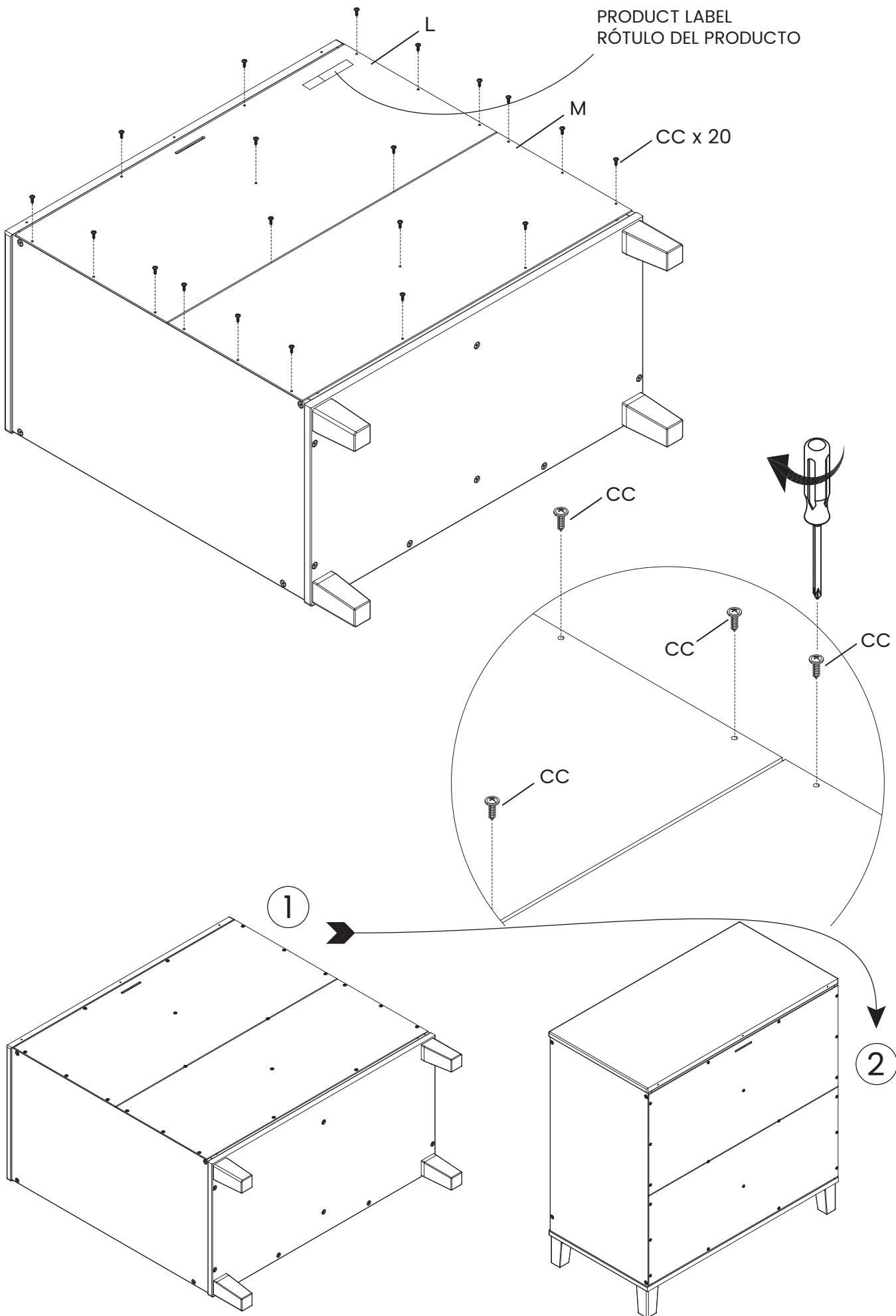

## CHANGING TABLE ASSEMBLY, STEP 12 ARMADO DEL CAMBIADOR, PASO 12

Parts and tools required to complete step

Piezas y herramientas necesarias para completar este paso

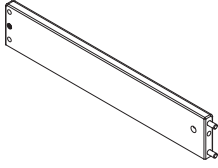

U

Changing Top Left Side x 1  
Lado izquierdo del cambiador x 1

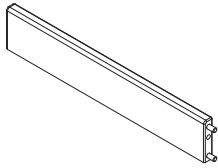

V

Changing Top Right side x 1  
Lado derecho del cambiador x 1

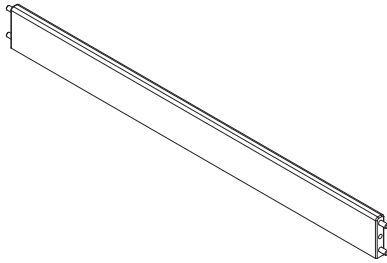

T

Changing Top Front x 1  
Parte frontal del cambiador x 1

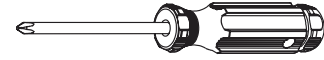

Phillips Screwdriver (Not Provided)  
Destornillador 'Phillips' (No siempre)

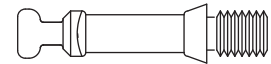

DD

Cam Bolt x 2  
Perno de Leva x 2

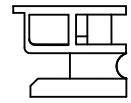
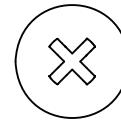

EE

Cam Lock x 2  
Bloqueo de Leva x 2

Attach (1) Changing Top Left Side (Part U) and (1) Changing Top Right side (Part V) to (1) Changing Top Front (Part T) using (2) Cam Bolts (Part DD) and (2) Cam Locks (Part EE). Tighten with the Phillips Screwdriver.

Fije (1) lado izquierdo del cambiador (Pieza U) y (1) lado derecho del cambiador (Pieza V) a (1) parte frontal del cambiador (Pieza T) utilizando (2) Pernos de Levas (Pieza DD) y (2) Bloqueos de Levas (Pieza EE). Apriete todos los pernos utilizando la Destornillador 'Phillips'.



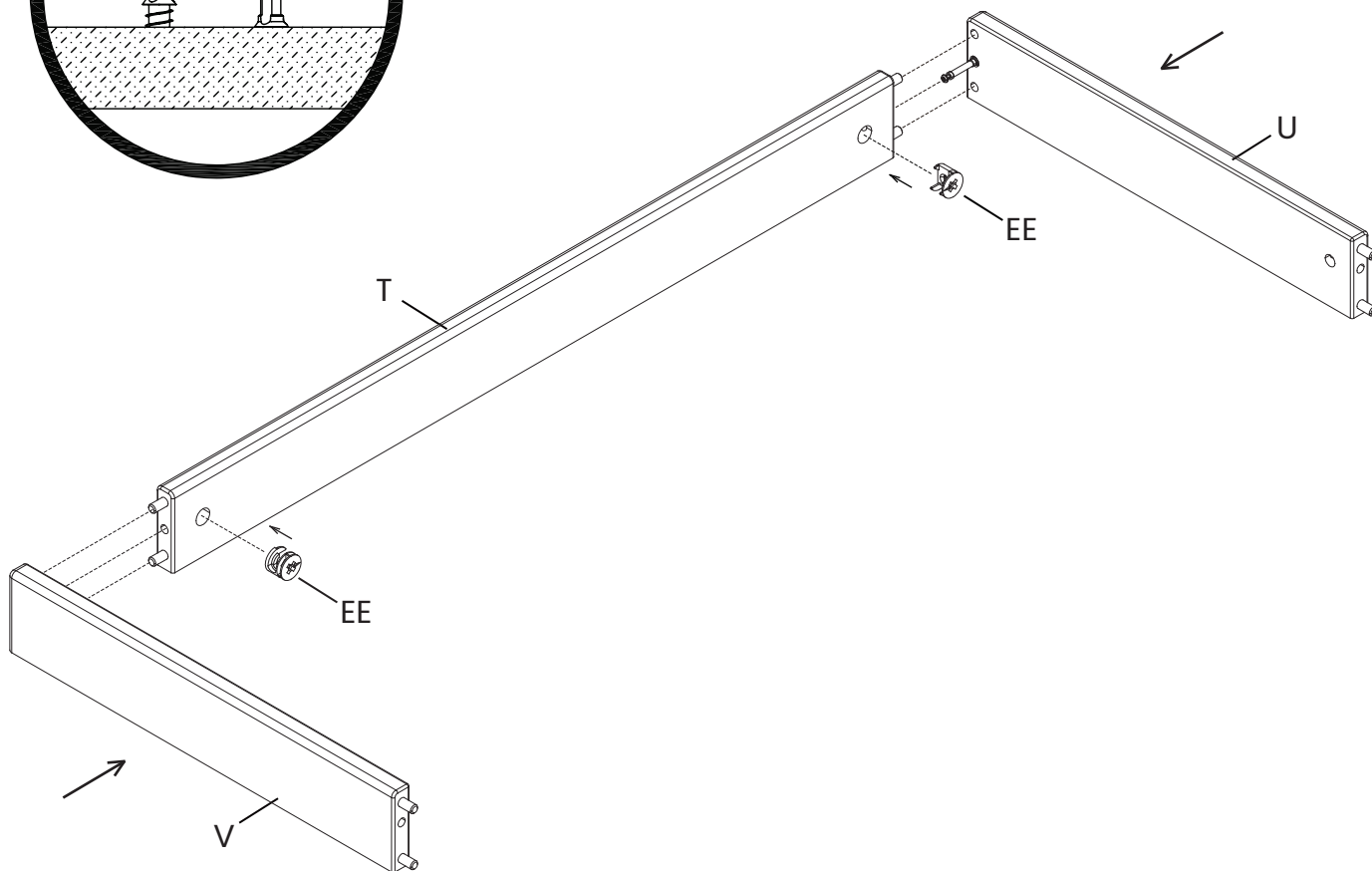
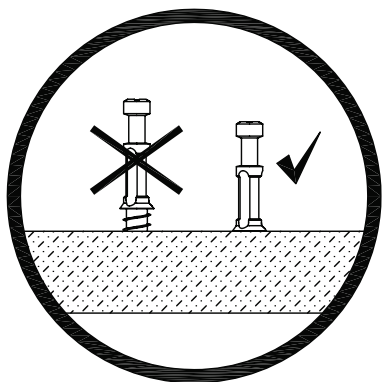
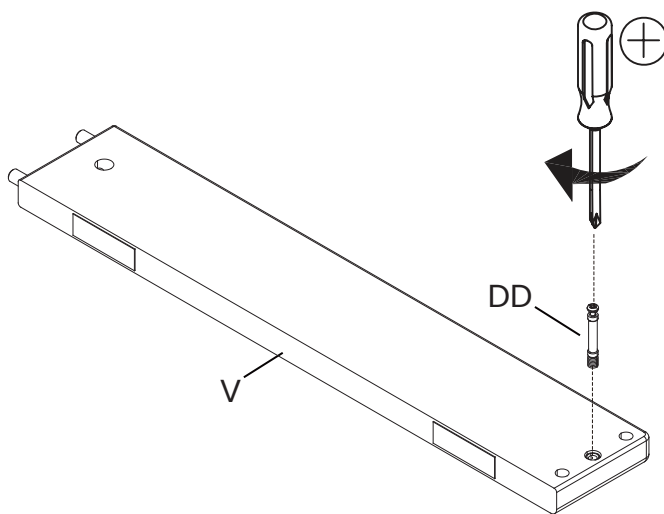
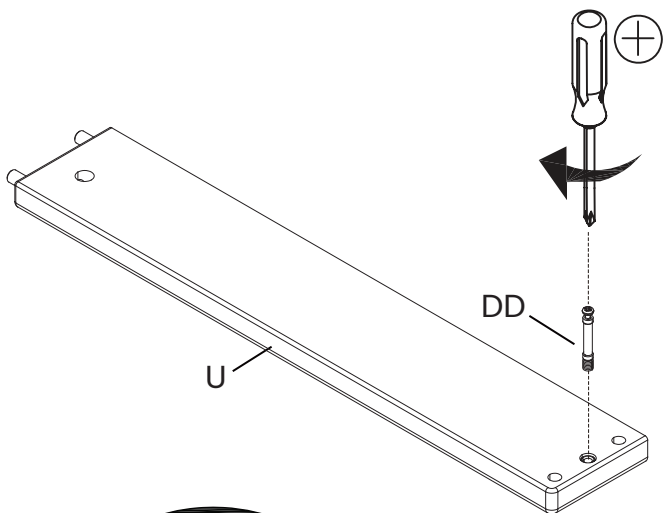

## CHANGING TABLE ASSEMBLY, STEP 13 ARMADO DEL CAMBIADOR, PASO 13

Parts and tools required to complete step

Piezas y herramientas necesarias para completar este paso



**S**

Changing Top Back x 1  
Parte posterior del cambiador x 1

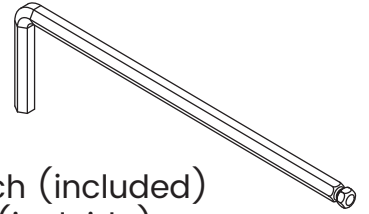

M4 Allen Wrench (included)  
Llave Allen M4 (incluido)



**Z**

M6x13mm Barrel Nut x 2  
Tuerca Cilíndrica M6x13mm x 2

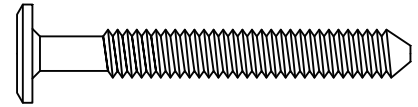
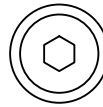

**W**

M6 x 50 mm Bolt x 2  
Perno M6 x 50mm x 2

Attach (1) Changing Top Back (Part S) to the assembly from step 12 using (2) M6 x 50 mm Bolts (Part W) and (2) M6 x13 mm Barrel Nuts (Part Z). Tighten with the M4 Allen Wrench. Use the Flat Head Screwdriver to hold the Barrel Nut in the proper alignment.

Fije (1) parte posterior del cambiador (Pieza S) al conjunto de piezas del paso 12 utilizando (2) pernos M6 x 50 mm (Pieza W) y (2) tuercas de barril M6 x 13 mm (Pieza Z). Apriete todos los pernos utilizando la Llave Allen M4. Utilice el destornillador de cabeza plana para sostener la tuerca de barril en la alineación adecuada.

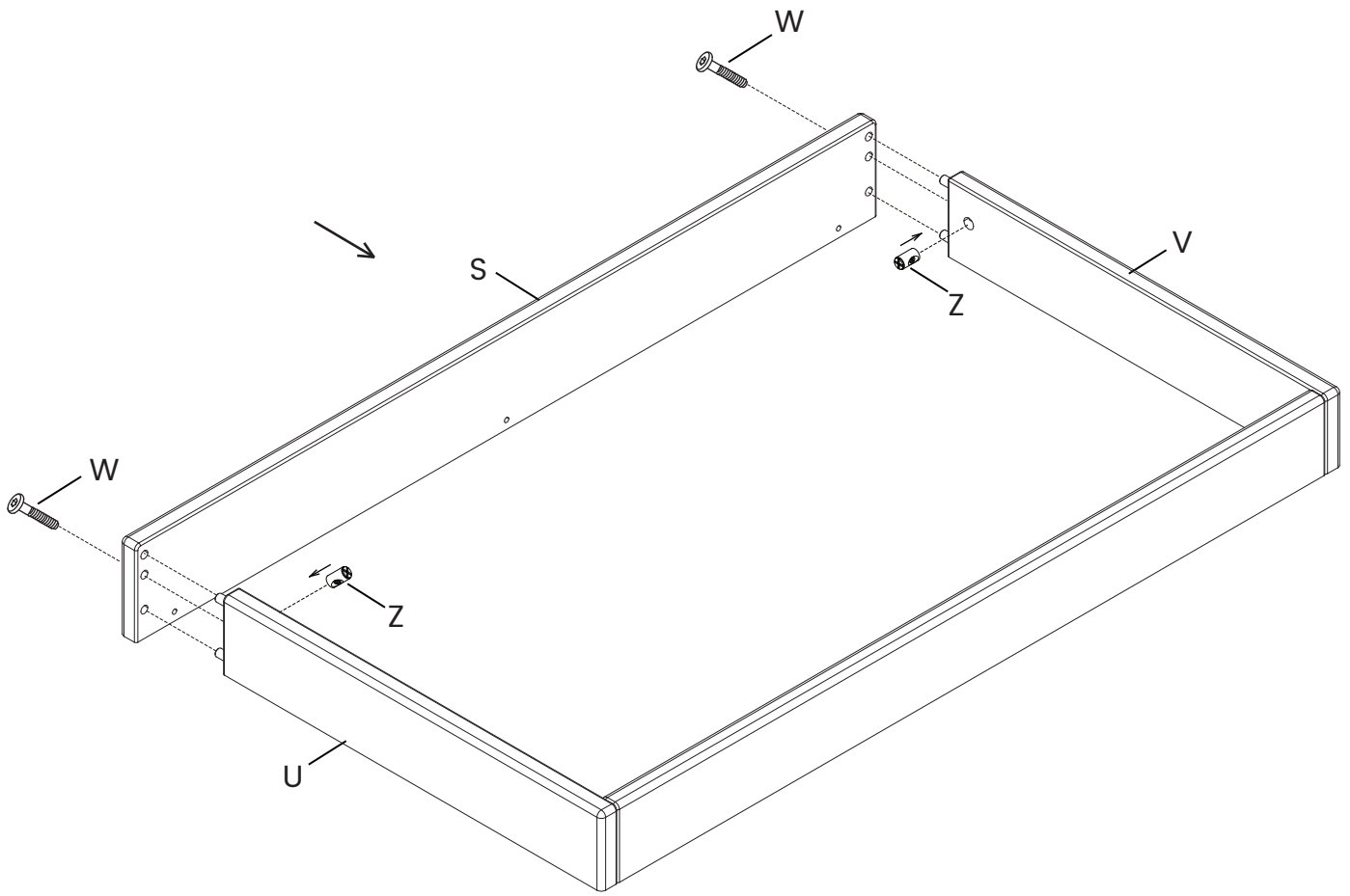

## CHANGING TABLE ASSEMBLY, STEP 14 ARMADO DEL CAMBIADOR, PASO 14

Parts and tools required to complete step

Piezas y herramientas necesarias para completar este paso

From Step 11  
Desde el paso 11

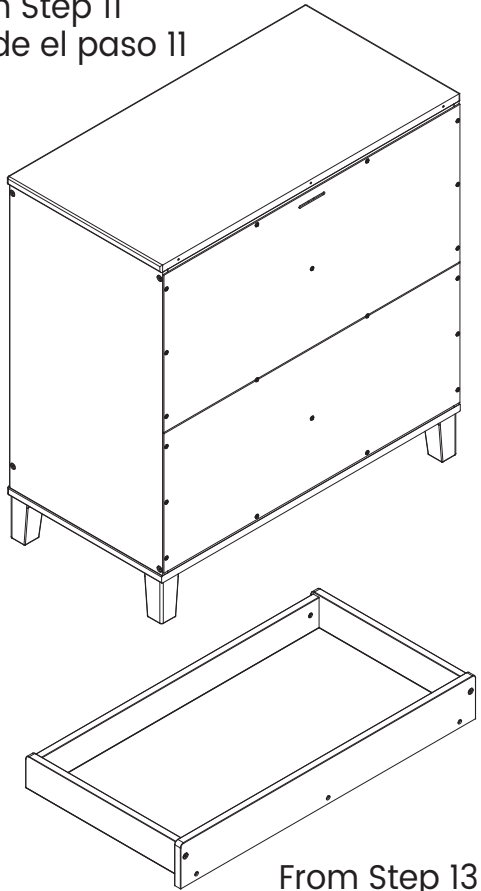

From Step 13  
Desde el paso 13



Phillips Screwdriver (Not Provided)  
Destornillador 'Phillips' (No siempre)

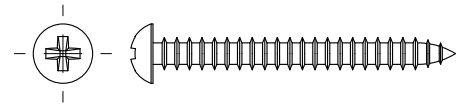

**BB** 40mm Screw x 3  
Tornillo 40mm x 3

1. Set the Assembled Changing Top on the top of the Dresser as shown.
2. Insert (3) 40mm screws (Part BB) through the back of the Changing Top, into the pre drilled holes the dresser.
3. Tighten with a Phillips Screwdriver.

1. Poner el equipó de ensamblaje encima del cambiador.
2. Inserta (3) tornillos 40 mm (pieza BB) en la parte de atrás en los agujeros pilotos.
3. Apriete con destornillador Phillips.

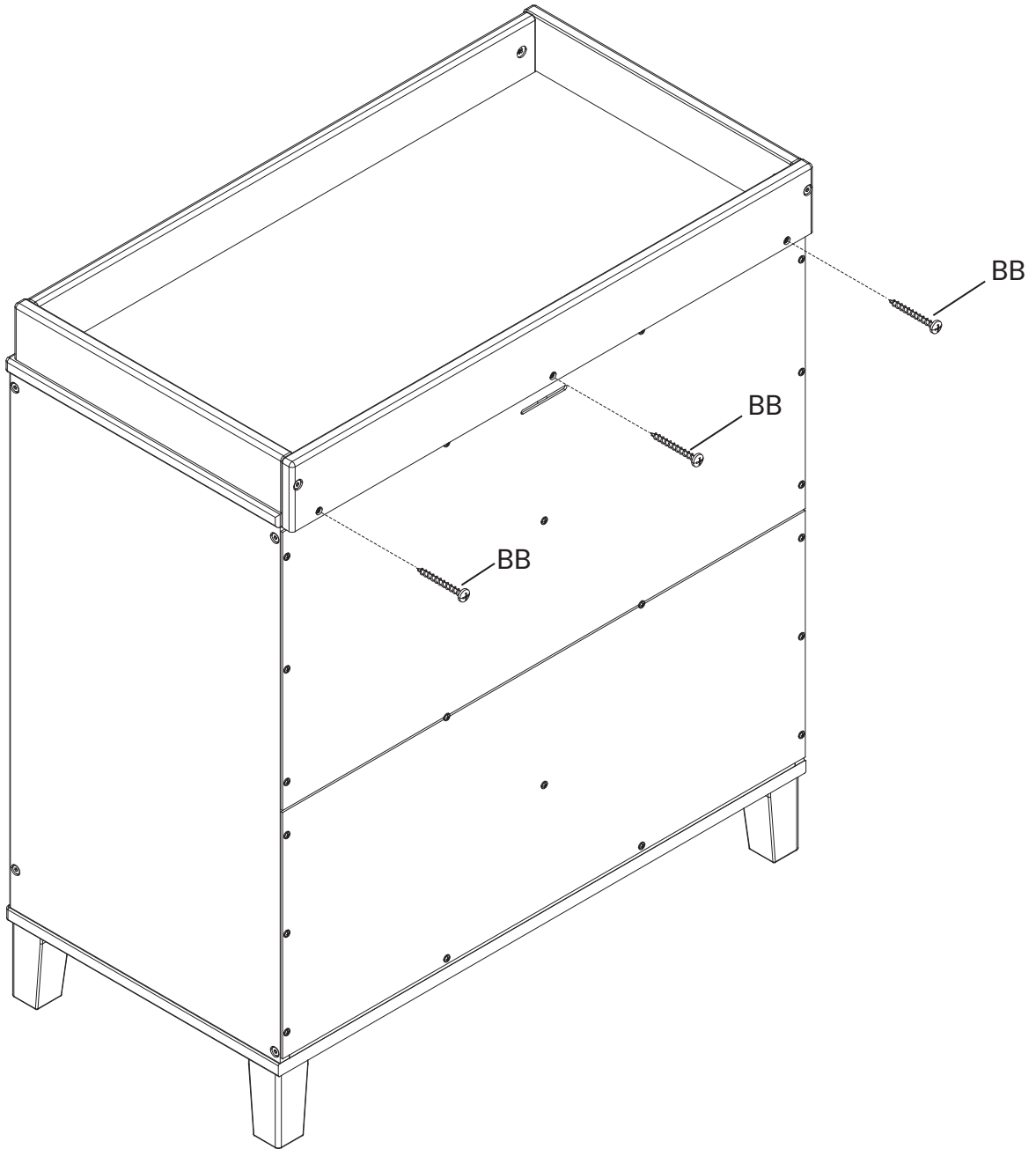

## Tipover Restraint Protección contra volcamiento

### ▲ WARNING

Use of tip-over restraints may only reduce, but not eliminate, the risk of tip-over.

Do not attempt to screw into the wallboard only. You must screw into a wood wall stud or other wood structure such as securely attached baseboard. If your wall is not wood stud construction, see your local hardware store or home center for a wall anchor system that will hold a pull force of 50 LBS in your wall type. If you are unsure of how to locate the wood stud, or of what type of wall you have, contact a professional contractor.

### ▲ ADVERTENCIA

El uso de herramientas de contención de vuelcos tan solo puede reducir, pero no eliminar, el riesgo de vuelco.

No intente atornillar a paredes hechas únicamente de paneles. Debe atornillar en un pilar u otra estructura de madera similar, como un zócalo fijado de manera segura. Si su pared no tiene vigas de Madera, visite su ferretería o tienda del ramo más cercana para conseguir un sistema de anclaje que soporte una fuerza de tiraje de hasta 50 LBS (22,7 Kgs) para su tipo de muro. Si no está seguro sobre cómo encontrar la viga de madera o tiene dudas sobre el tipo de muro, contacte a un contratista profesional.

- 1) Locate the hole in Changer Rail.
- 2) Align the hole to be used with the wood wall stud (For Open Bottom Installation, use wood wall stud closest to center)

- 1) Ubique los orificios pasantes en la parte posterior del mueble.
- 2) Alinee el orificio que utilizará con el pilar de la pared (para una instalación con fondo abierto, utilice el pilar de madera más cercano al centro)

- 3) Make a pencil mark on the wall using the wood rail as a guide, pencil mark must be over wood wall stud. Then move the case away from the wall.

- 3) Utilizando un lápiz, haga una marca en la pared utilizando el barra de madera como guía; la marca debe estar sobre el pilar de madera. Luego, aleje la carcasa de la pared.

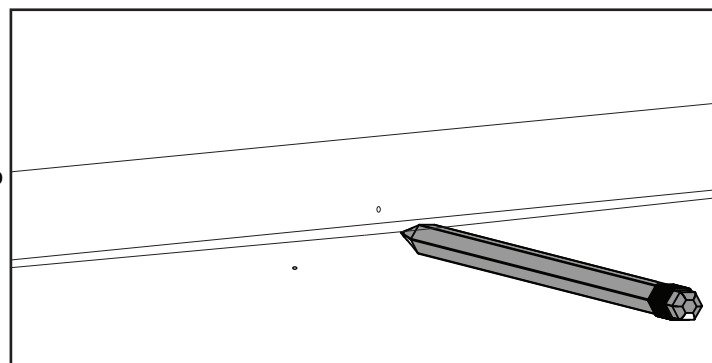

- 4) Drill  $\text{\O}1/8$ " hole at Pencil Mark, in wood wall stud

- 4) Perfore un orificio de  $\text{\O}1/8$ " en la marca del lápiz, sobre el pilar de madera

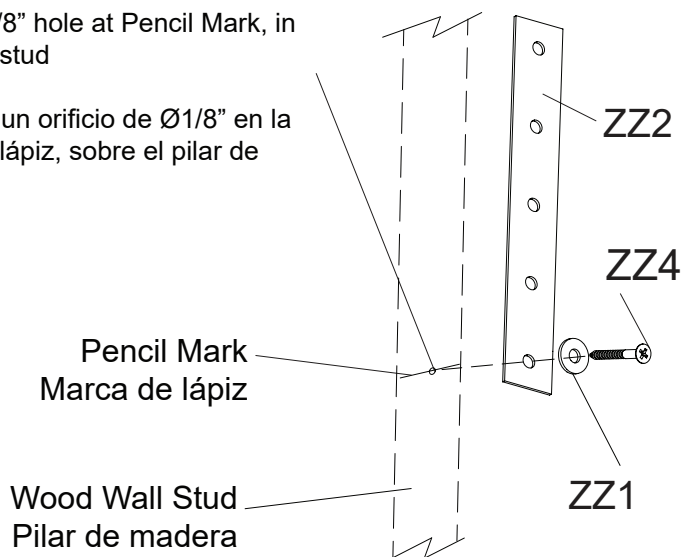

- 5) Attach the Tip-over restraint strap (ZZ2) to the wall using (1) Long Screw (ZZ4) and (1) washer (ZZ1) as shown. The screw **MUST** be installed into a wood wall stud (See WARNINGS for additional information).

- 5) Fije la correa de retención contra volcamiento (ZZ2) a la pared utilizando (1) tornillo largo (ZZ4) y (1) arandela (ZZ1), como se indica. El tornillo **DEBE** instalarse en un pilar de madera (para obtener más información consulte las ADVERTENCIAS).

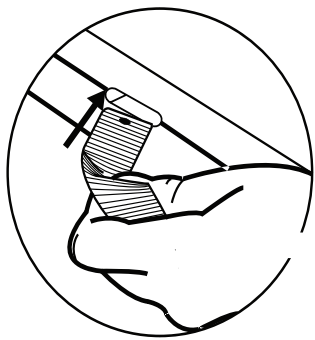

NOTE: Be sure to attach any accessory items to case before completing this step.  
6) Feed the Tipover Restraint through the hole as you place the dresser in it's final position.

NOTA: Asegúrese de fijar todos los accesorios a la carcasa antes de completar este paso.  
6) Pase el elemento de retención a través del orificio, a medida que posiciona el mueble en su posición final.

7) Fasten it securely to the case using (1) 15mm screw (ZZ3) and (1) washer (ZZ1).

7) Fíjelo con seguridad a la carcasa utilizando (1) tornillo de 15 mm (ZZ3) y (1) arandela (ZZ1).

Attach to Top  
Fijar a la parte superior

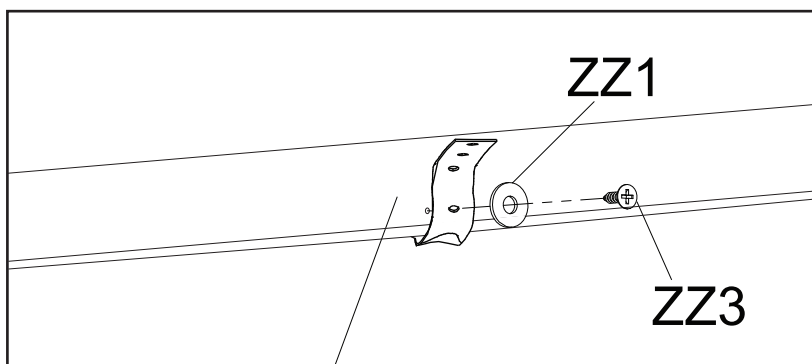

Top Back Rail  
Barra Trasero Superior

8) Pull case AWAY from wall until Restraint is SNUG.

8) Jale la carcasa ALEJÁNDOLA de la pared hasta que la retención esté TENSA.

9) Ensure restraint is not loose.

9) Asegúrese de que la retención no esté suelta.

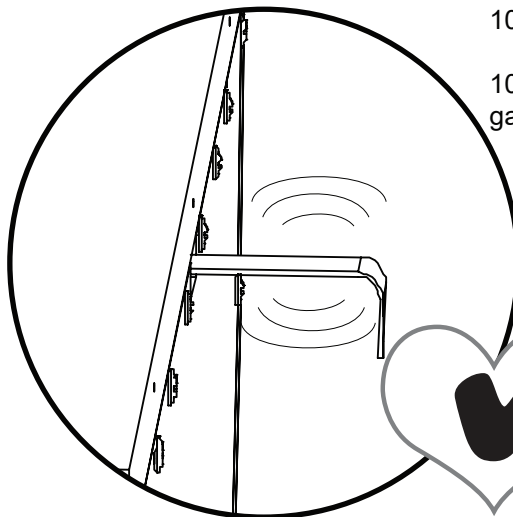
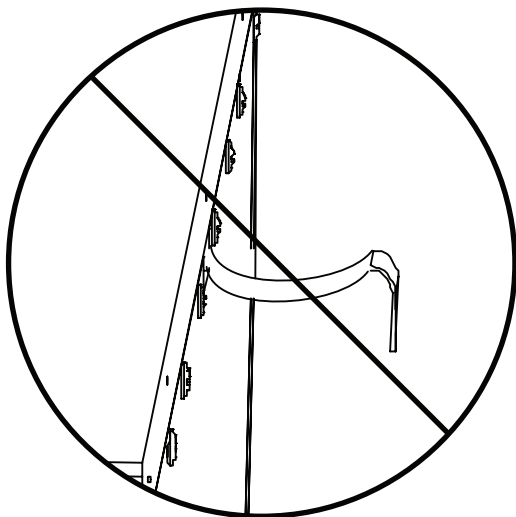

10) Replace the drawers.

10) Vuelva a poner las gavetas.

**⚠ WARNING**

**Fall Hazard** Children have suffered serious injuries after falling from changing tables. Falls can happen quickly.

- **STAY** within arm's reach of the child.
- Read all instructions before use of the changing top.
- **KEEP THESE INSTRUCTIONS IN A SAFE PLACE FOR FUTURE USE.**
- Inspect the changing table periodically. Do not use the changing top if it is damaged or broken. Contact Delta Children's Products with any questions.
- Tighten all loose screws and bolts before each use.
- The maximum recommended weight of the child is 30lbs for the changing table.
- Secure the changing unit only to Delta Children's Products item W146010.
- The changing pad used should be 32" x 16" with a maximum thickness of 1".

**NOTES ON ASSEMBLY:**

- During the assembly process whenever using screws or bolts, check each by placing the screw/bolt on the diagram of the item which is drawn actual size and design. Be sure to use the proper size and shape specified in the instructions.
- To assemble this unit you may be required to place the unit on it's side and face. It is strongly recommended that assembly is done on a soft, non-abrasive surface to avoid damaging the finish.

**NOTES ON USE:**

Keep children and others safe by following these simple rules:

- **Do not** allow any child to play on furniture
- **Do not** allow climbing on any piece of furniture.
- **Do not** allow hanging from any piece of furniture.
- Always monitor your child's activity when in the nursery.

**NOTES ON CARE AND MAINTENANCE:**

- **Do not** scratch or chip the finish.
- Inspect the product periodically, contact Delta Children's Products for replacement parts or questions.
- **Do not** store the product or any parts in extreme temperatures and conditions such as a hot attic or a damp, cold basement. These extremes can cause a loss of structural integrity.
- To preserve the luster of the high quality finish on your product, it is recommended to place a doily or felt pad under any items you place on the finish.
- Clean with a damp cloth, then a dry cloth to preserve the original luster and beauty of this fine finish.
- **Do not** use abrasive chemicals.
- **Do not** spray cleaners directly onto furniture.
- Lift slightly when moving on carpeting to prevent leg breakage.
- Use of a vaporizer near furniture will cause wood to swell and finish to peel.



# ⚠️ ADVERTENCIA

**Peligro de caídas.** Hay niños que han sufrido lesiones serias al caer de cambiadores. Las caídas pueden ocurrir en un instante.

- **MANTENERSE** al alcance de la mano del niño.
- Lea todas las instrucciones antes de usar el cambiador.
- **COLOQUE ESTAS INSTRUCCIONES EN UN LUGAR SEGURO PARA SU USO FUTURO.**
- Inspeccione este cambiador periódicamente. No use el cambiador si está dañado o roto. Póngase en contacto con Delta Children's Products para formular preguntas.
- Apriete los tornillos y pernos flojos antes de cada uso.
- El peso máximo recomendado para los niños que usen el cambiador es 30 libras (13,6 kilos).
- Asegure el cambiador sólo al producto Delta Children's Products W146010.
- La almohadilla usada debe ser 32 x 16 pulgadas con un grosor máximo de 1 pulgada.

## INFORMACIÓN SOBRE EL MONTAJE:

- Durante el proceso de montaje, ya utilice pernos o tornillos, compruebe cada uno de ellos colocando el perno/tornillo en el diagrama del artículo donde está dibujado el tamaño y el diseño real. Asegúrese de que utiliza el tamaño y la forma adecuada que especifican las instrucciones.
- Para montar esta unidad, puede que se le solicite que coloque la unidad de lado y de cara. Se recomienda encarecidamente que realice el montaje sobre una superficie no abrasiva (Como la envoltura de embalaje de espuma) para evitar dañar el acabado.

## INFORMACIÓN SOBRE EL USO:

Mantenga a los niños y otras personas a salvo siguiendo estas sencillas reglas:

- **No permita** que ningún niño juegue sobre muebles.
- **No permita** que nadie trepe sobre un mueble.
- **No permita** que nadie se cuelgue de un mueble.
- Vigile siempre la actividad de su hijo cuando se encuentre en su cuarto.

## NOTAS SOBRE SU CUIDADO Y MANTENIMIENTO:

- **No** arañe ni desconche el acabado.
- Inspeccione el producto con regularidad, póngase en contacto con Delta Children's Products para el recambio de partes o para formular preguntas.
- **No** guarde el producto ni ninguna de sus partes a temperaturas ni en condiciones extremas como un ático caluroso o un sótano húmedo y frío. Estos extremos pueden provocar una pérdida de integridad estructural.
- Para preservar el brillo del acabado de alta calidad que recubre su producto, se recomienda que coloque un paño o una almohadilla de fieltro debajo de cualquier objeto que coloque sobre el acabado.
- Límpielo con un trapo húmedo y luego con uno seco para preservar el brillo y la belleza originales de este fino acabado.
- **No** utilice productos químicos abrasivos.
- **No** pulverice limpiadores directamente sobre el mueble.
- Elévelo ligeramente cuando lo mueva sobre alfombras o moqueta para evitar que se rompan las patas.
- El uso de vaporizadores cerca de muebles puede provocar que la madera se hinche y acabe desconchándose.

## Limited Warranty:

This Delta Product is warranted to be free from defects for a period of 90 days from the date of purchase under normal use. If a product is defective during this period, we will at our option repair or replace the defective part or product. This limited warranty extends only to the original retail purchaser and is valid only when supplied with proof of purchase, or if received as a gift, when the registration is on file with Delta. This limited warranty does not cover the following:

- Products purchased as floor models or samples.
- Items purchased on an “as-is” basis, as a second hand product, or as a resale product.
- Items purchased at a Final sale, a “Going out of Business” sale or a Liquidation sale.

This limited warranty gives you specific legal rights and you may also have other rights which vary from state to state.

### To register your product

for important safety alerts and updates to your product please visit  
[www.deltachildren.com](http://www.deltachildren.com)

### To report a problem

please log on to [www.deltachildren.com/help](http://www.deltachildren.com/help)

Date of Purchase: \_\_\_\_\_ (you should also keep your receipt)

## Garantía Limitada:

Este Producto Delta está garantizado de estar libre de defectos por un período de 90 días a partir de su adquisición, bajo uso normal. Si un producto tiene defectos durante este período, Nosotros tomaremos la opción de reparar o reemplazar la pieza defectuosa del producto. Esta garantía limitada se otorga únicamente al comprador original y es válida solamente cuando se proporciona una prueba de compra, o si el producto fue recibido como un regalo, debe haber sido registrado con Delta. Esta garantía limitada del fabricante no cubre lo siguiente:

- Productos comprados como exhibiciones de la tienda o muestras.
- Artículos comprados como “tal como está”, productos de segunda mano o reventa de los productos.
- Artículos comprados como “venta final”, “ventas de tiendas que están quebrando” o ventas por liquidación.

Esta garantía limitada le otorga derechos legales específicos y también puede tener otros derechos que varían de un estado a otro.

### Para registrar su producto

para alertas importantes de seguridad y estar al tanto sobre novedades de su producto por favor visite  
[www.DeltaChildren.com](http://www.DeltaChildren.com)

### Para reportar cualquier problema

por favor entre a [www.DeltaChildren.com/help](http://www.DeltaChildren.com/help)

Fecha de Compra: \_\_\_\_\_ (debe además mantener su recibo)

# POR QUÉ ELEGIR A DELTA CHILDREN?

Visita [Deltachildren.Com/Pages/Our-Story](http://Deltachildren.Com/Pages/Our-Story) para más información

<p><b>DELTA LIDERA</b> 1 de cada 2 niños en los EE.UU duerme en nuestros productos</p>	<p><b>DELTA DONA</b> 10% de nuestros ingresos está destinado a mejorar la vida de los niños</p>	<p><b>A DELTA LE IMPORTA</b> Hacemos pruebas por encima de los estándares de seguridad de la industria</p>	<p><b>DELTA ESTÁ DEDICADA</b> Nuestra empresa familiar ha estado siempre presente para su familia desde 1968</p>	<p><b>DELTA CRECE CON USTEDES</b> Tenemos productos para cada edad y etapa</p>	<p><b>Más De 50 Años De Seguridad, Estilo E Innovación</b></p>
--	---	--	--	--	--

Bienvenido a la **FAMILIA DELTA**  
Aquí Está Nuestro Regalo Para Usted

# 10% OFF

Su Próxima Compra En [DeltaChildren.com](http://DeltaChildren.com)

UTILICE EL CÓDIGO:  
**DELTA10**

## PRODUCTOS PARA CADA EDAD Y ETAPA

 CUNAS	 COSAS PARA BEBÉ	 SILLA	 MOISÉS	 COLCHÓN	
 CARRIOLAS	 CAMA PARA NIÑO	 CUARTO DE JUGAR	 CAMA SENCILLA	 CONTENEDORES	 TOCADORES

## NUESTRA FAMILIA DE LAS MEJORES MARCAS



MÁS DE 50 AÑOS DE SEGURIDAD, ESTILO E INNOVACIÓN

# WHY CHOOSE DELTA CHILDREN?

Visit [Deltachildren.Com/Pages/Our-Story](http://Deltachildren.Com/Pages/Our-Story) for more information

<p><b>DELTA LEADS</b> 1 Out Of 2 Children In The U.S. Sleep In Our Products</p>	<p><b>DELTA GIVES</b> 10% Of Our Profits Go Toward Improving The Lives Of Children</p>	<p><b>DELTA CARES</b> We Test Above &amp; Beyond Industry Safety Standards</p>	<p><b>DELTA IS DEDICATED</b> Our Family-Run Company Has Been There For Your Family Since 1968</p>	<p><b>DELTA GROWS WITH YOU</b> We Have Products For Every Age And Stage</p>	<p><b>Over 50 Years Of Safety, Style &amp; Innovation</b></p>
---	--	--	---	---	---

Welcome to the **DELTA FAMILY**  
Here's a Gift From Us To You

# 10% OFF

Your Next Purchase From [DeltaChildren.com](http://DeltaChildren.com)

**USE CODE:**  
**DELTA10**

\*Exclusions Apply  
\*Subject to Change

## PRODUCTS FOR EVERY AGE AND STAGE

 <b>CRIBS</b> LITS POUR BÉBÉ CUNAS	 <b>STROLLERS</b> ÉQUIPEMENT POUR BÉBÉ COSAS PARA BEBÉ	 <b>GLIDERS</b> CHAISE SILLA	 <b>BASSINETS</b> COUFFINS MOISÉS	 <b>MATRESSES</b> MATELAS COLCHÓN	
 <b>BABY GEAR</b> POUSSETTES CARRIOLAS	 <b>TODDLER BEDS</b> LITS POUR ENFANT CAMA PARA NIÑO	 <b>PLAYROOM FURNITURE</b> SALLE DE JEUX CUARTO DE JUGAR	 <b>TWIN BEDS</b> LITS UNE PLACE CAMA SENCILLA	 <b>BINS &amp; ORGANIZERS</b> PANIERES CONTENEDORES	 <b>DRESSERS</b> COMMODES TOCADORES

### OUR FAMILY OF TOP BRANDS



OVER 50 YEARS OF SAFETY, STYLE, AND INNOVATION