

DELUXE MOSES BASSINET



INSTRUCTION MANUAL

ADULT ASSEMBLY REQUIRED

Style 27280

STYLES AND COLORS MAY VARY

REQUIRED: 3 x AA Batteries
(not included)
Screwdriver
(not included)

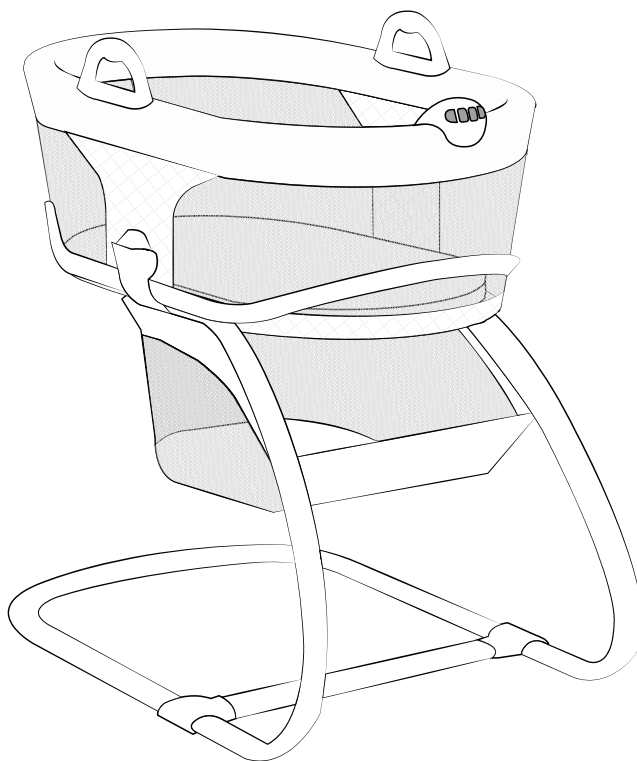

**▲ WARNING:
CHOKING HAZARD**

Adult assembly required because of small parts. Keep assembly parts out of reach of children under 3 years.

Read all instructions BEFORE assembly and USE of product
KEEP INSTRUCTIONS FOR FUTURE USE.

Customer Experience Center
phone: (646) 435-8726
email: gcs@DeltaChildren.com



www.DeltaChildren.com

DCP-IM-20200527

Consumer Information



WARNING

Failure to follow these warnings and instructions could result in serious injury or death. Read all instructions before assembling unit. **KEEP INSTRUCTIONS FOR FUTURE USE. DO NOT USE THIS UNIT IF THE INSTRUCTIONS CANNOT BE STRICTLY FOLLOWED.**

- Before each usage or assembly, inspect unit for damaged hardware, loose joints, missing parts or sharp edges. **NEVER** use this product if there are any loose or missing fasteners, loose joints, broken parts, or torn mesh/fabric. Check before assembly and periodically during use. Contact Delta Children's Products Customer Service Department at 646-435-8726 for replacement parts, repair or instructions.
- **DO NOT** substitute parts.
- **FALL HAZARD**—To help prevent falls, **DO NOT** use this product when the infant begins to push up on hands and knees or has reached manufacturer's recommended maximum weight of 30lbs. (13.6kg), whichever comes first.
- Electronic housing requires 3 "AA" (not included)
- Tools required: Phillips head screwdriver (not included)
- Use bassinet with only one child at a time.
- **NEVER** leave child unattended.
- **NEVER** use near stairs or steps.
- Child's movement can slide Moses Bassinet.
- **NEVER** place the Moses Basket near edges of counter tops, table or other elevated surfaces. Your Moses Bassinet can roll over on soft surfaces and suffocate child.
- **NEVER** place the Moses Basket as a mean to transport an infant in a motor vehicle.

SUFFOCATION HAZARD: INFANTS CAN SUFFOCATE:

- In gaps between an extra pad and side of the bassinet/cribble and on soft bedding.
- Use **ONLY** the pad provided by the manufacturer. **NEVER** add a pillow, comforter or another mattress for padding.
- If a sheet is used with the pad, use only the one provided by the manufacturer or one specifically designed to fit the dimensions of the bassinet/cribble.
- To reduce the risk of SIDS, pediatricians recommend healthy infants be placed on their back to sleep, unless otherwise advised by your physician.
- Strings can cause strangulation! **DO NOT** place items with a string around a child's neck, such as hood strings or pacifier cords. **DO NOT** suspend strings over a product or attach strings to toys.
- **NEVER** use plastic shipping bags or other plastic film as a mattress covers not sold and intended for that purpose. They can cause suffocation.
- **NEVER** move, lift or transport bassinet while child is in it.
- **DO NOT** place bassinet near a window where cords from blinds or drapes may strangle a child. Child may fall out of window.
- **DO NOT** place cords, straps or similar items that could become wound around a child's neck in or near the bassinet.
- **ALWAYS** ensure that the bassinet sleeping area is secure to base.
- **ALWAYS** use on flat, stable surfaces.
- **TO PREVENT A HAZARDOUS, UNSTABLE CONDITION, DO NOT** place more than 5lbs (2.27 kg) in the storage basket.
- **DO NOT** use storage basket as a child carrier.
- **DO NOT ALLOW** your child to stand on the basket. It may collapse and cause injury.

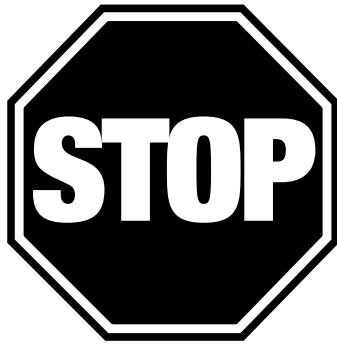

Before returning this product to the store! Let's see if we can assist you!

- **Not sure how to assemble our product?**

Visit our site for easy to follow instructions along with some Tricks and Tips assembly video's
<https://www.deltachildren.com/pages/instructions>

- **If you are missing a piece or have a damaged part**

Please contact our Consumer Experience Center for assistance at 646-435-8726.

To better assist you please have your Style #, Lot # and Manufacturer Date information available along with the part number that you need assistance with.

- **In the event we do not have a replacement part available**

You may need to return your product to the retailer for an exchange or refund.

- **Warranty**

In order to protect your investment, don't forget to register your product.

You may also wish to consider purchasing our extended warranty.

Visit <https://www.deltachildren.com/pages/extended-warranty> for more details.

- **Please note:**

"All Final", "As Is" or Third Party/Liquidator sales are not covered under our Limited Limited Manufacturer Warranty..

DELTA CHILDREN

LIMITED MANUFACTURER WARRANTY

This Delta product is warranted to be free from defects for a period of 90 days from the date of purchase under normal use. This warranty extends only to the original retail purchaser and is valid only when supplied with proof of purchase, or if received as a gift, when the registration is on file with Delta. This limited manufacturer warranty does not cover the following:

- Products purchased as floor models or samples.
- Items purchased on an “as-is” basis, as a second hand product, or as a resale product.
- Items purchased at a Final sale, a “Going out of Business” sale, or a Liquidation sale.

TO REGISTER YOUR PRODUCT for important safety alerts and updates to your product please visit www.deltachildren.com

TO REPORT A PROBLEM, please log on to www.deltachildren.com and click the Consumer Care Tab, or contact us by phone at 646-435-8726

Date of Purchase: _____ (you should also keep your receipt)

EXTENDED WARRANTY

DON'T MISS YOUR CHANCE TO BE COVERED FOR ALL OF LIFES MISHAPS!

With Delta's Extended Warranty, you're covered for mechanical failure from normal use or if your item stops working due to normal wear and tear, plus all those unexpected surprises.

2 YEARS OF PROTECTION

For Additional Information:

Simply visit our Website, register your product, and add the Extended Warranty

<https://www.deltachildren.com/pages/product-registration>

Extended Warranty only available in the following States: Arkansas, Colorado, Delaware, District of Columbia, Georgia, Idaho, Illinois, Indiana, Iowa, Kansas, Kentucky, Louisiana, Maryland, Michigan, Mississippi, Missouri, Nebraska, Nevada, New Hampshire, New York, North Carolina, North Dakota, Pennsylvania, Rhode Island, South Dakota, Tennessee, Utah, West Virginia

Parts

IMPORTANT! Please remove all parts from the package and identify them before assembly.

IMPORTANT! Before assembly and each use, inspect this product for damaged hardware, loose joints, missing parts, or sharp edges. NEVER use if any parts are missing or broken. Contact manufacturer for replacement parts and instructions if needed. Never substitute parts. IMPORTANT! Adult assembly is required.



U shaped bar



Cross Support Tube



Right Leg

Left Leg



Plastic Connector



Frame



Undercarriage Basket

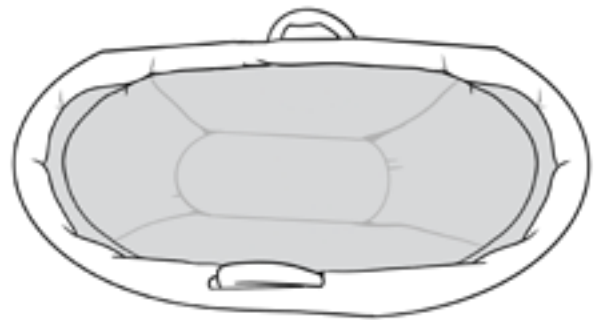

Fabric Cover

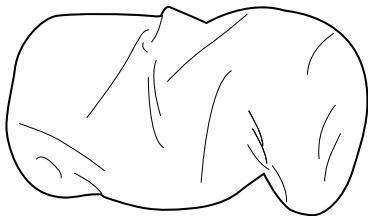

Sheet

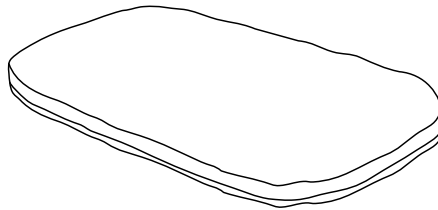

Mattress Pad



Music Module



Hardware (Screws)

Frame Assembly

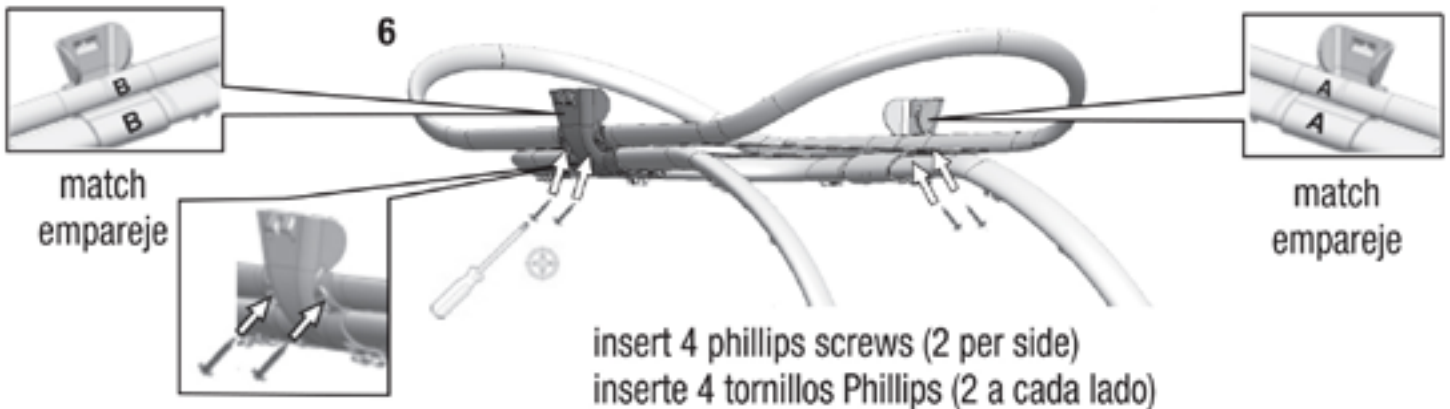
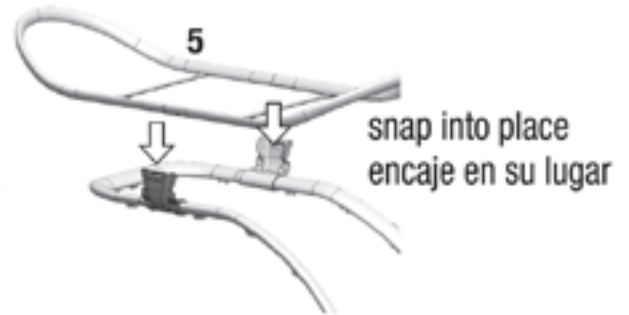
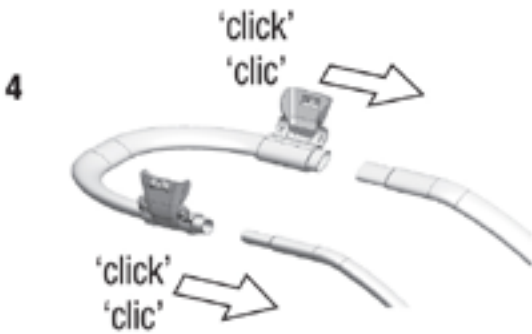
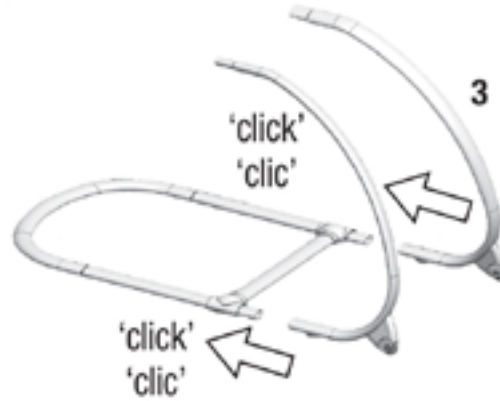
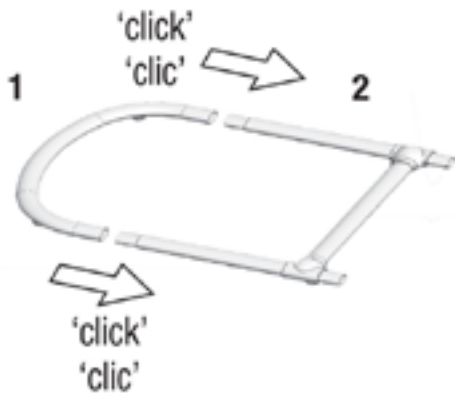

Basket Assembly

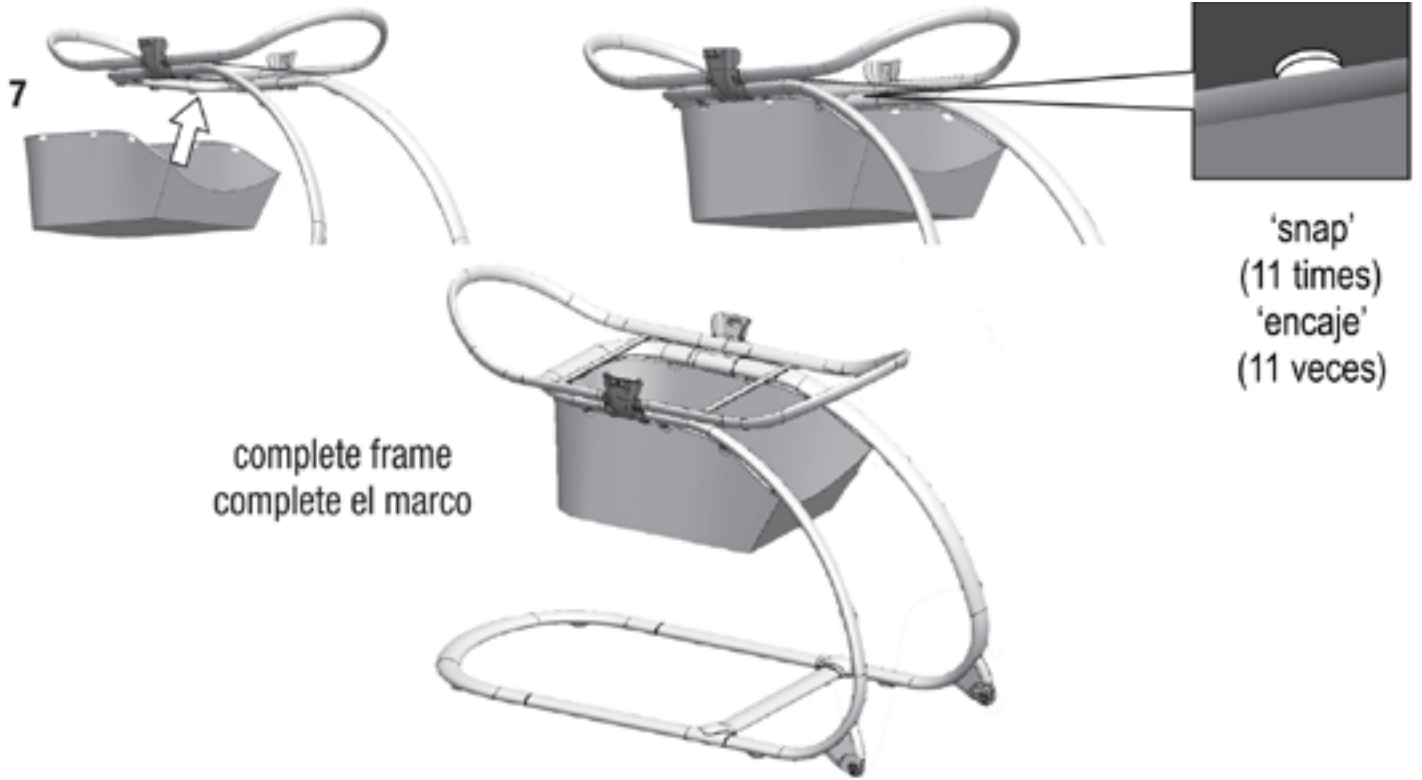

Bassinet Assembly

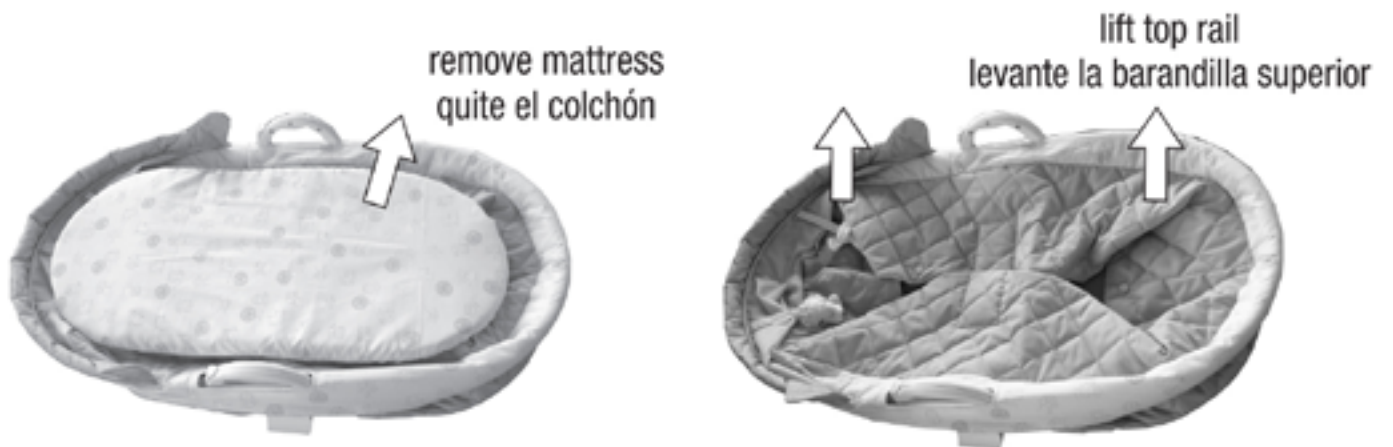

Bassinet Assembly

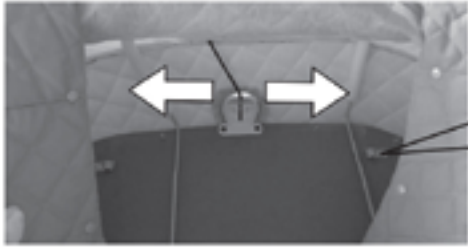

push out support bars
quite las barras de soporte



'click' (4 times)
haga 'clic' (4 veces)

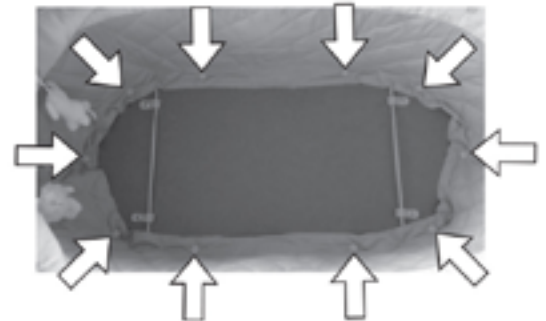

'snap' (10 times)
'encaje' (10 veces)

replace mattress
reposicione el colchón

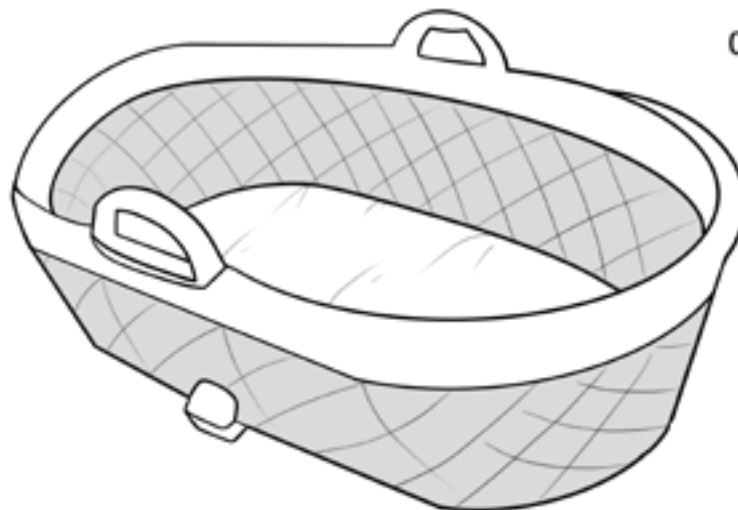

complete bassinet
moisés completo

Consumer Information



WARNING

Read all instructions BEFORE assembly and USE of product. KEEP INSTRUCTIONS FOR FUTURE USE.

- A mobile is intended for visual stimulation and is not intended to be grasped by the child.
- From birth to 5 months.

Possible entanglement injury.

Keep out of baby's reach.

Remove mobile from bassinet or cradle when baby begins to push up on hands and knees.

Toys are not meant to be "mouthed" by the baby and should be positioned clearly out of reach of the baby's face and mouth.

Adult assembly required

Always attach all provided fasteners (strings, straps, clamps etc.) tightly to the bassinet according to the instructions. Check frequently.

Do not add additional strings or straps to attach to the bassinet.

The mobile is not intended for use in playpens or portable cribs.

CAUTION - Changes or modifications not expressly approved by the party responsible for compliance could void the user's authority to operate the equipment.

NOTE: This device complies with Part 15 of the FCC Rules.

Operation is subject to the following two conditions:

(1) this device may not cause harmful interference, and (2) this device must accept any interference received, including interference that may cause undesired operation.

NOTE: This equipment has been tested and found to comply with the limits for a class B digital device pursuant to Part 15 of the FCC Rules. These limits are designed to provide reasonable protection against harmful interference in a residential installation. This equipment generates, uses and can radiate radio frequency energy and, if not installed and used in accordance with the instructions, may cause harmful interference to radio communications. However, there is no guarantee that interference will not occur in a particular installation. If this equipment does cause harmful interference to radio or television reception, which can be determined by tuning the equipment off and on, the use is encouraged to try to correct the interference by one or more of the following measures:

- **Reorient or relocate the receiving antenna.**
- **Increase the separation between the equipment and receiver.**
- **Connect the equipment into an outlet on a circuit different from that to which the receiver is connected.**
- **Consult the dealer or experience radio/TV technician for help.**





Batteries Safety Information

In exceptional circumstances, batteries may leak fluids that can cause a chemical burn injury or ruin your product. To avoid battery leakage:

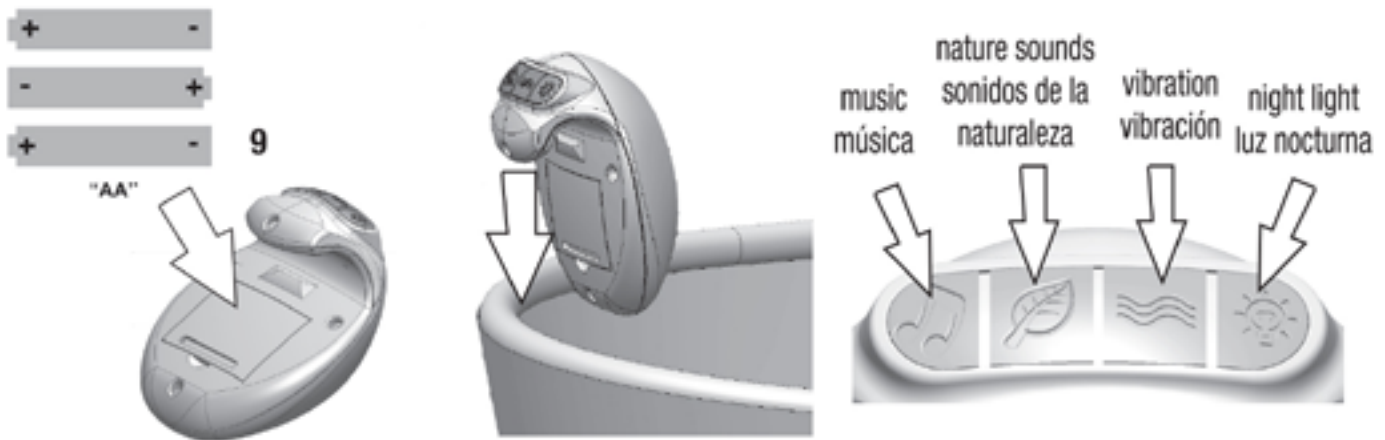
- Do not mix old and new batteries or batteries of different types: Alkaline, standard (carbon zinc) or rechargeable (nickel-cadmium).
- Insert batteries as indicated inside battery compartment.
- Remove batteries during long periods of non-use. Always remove exhausted batteries from the product. Dispose of batteries safely. Do not dispose of product in a fire. The batteries inside may explode or leak.
- Never short-circuit the battery terminals.
- Use only batteries of the same or equivalent type as recommended.
- Do not charge non-rechargeable batteries.
- Remove rechargeable batteries from the product before charging.
- If removable, rechargeable batteries are used, they are only to be charged under adult supervision.

Music Module Set Up and Operation



- 
- 
 - Press for music
 - Press to increase volume
 - Press to turn off
 - Auto shut off feature
 - 
 - Press for Mature Sounds
 - Press to increase volume
 - Press to turn off
 - Auto shut off feature
 - 
 - Press for Vibration
 - Press to increase speed
 - Press to turn off
 - Auto shut off feature
 - 
 - Press to turn light on
 - Press to turn off
 - Auto shut off feature

Connecting Bassinet to Frame

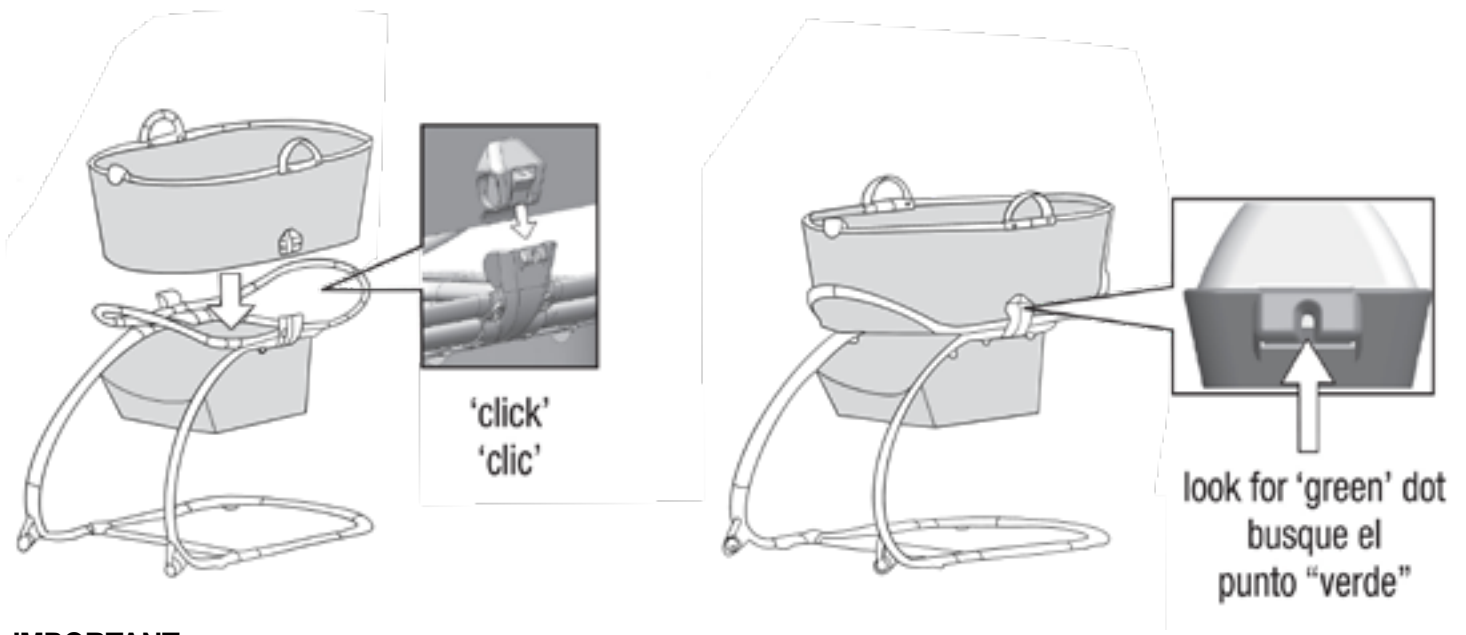

IMPORTANT:

Always be sure the moses basket is properly latched to the frame before use. Pull up on carry handles to be sure the moses basket does not separate from the frame. DO NOT use on frame if moses basket will not properly latch on.

Removing Bassinet from Frame

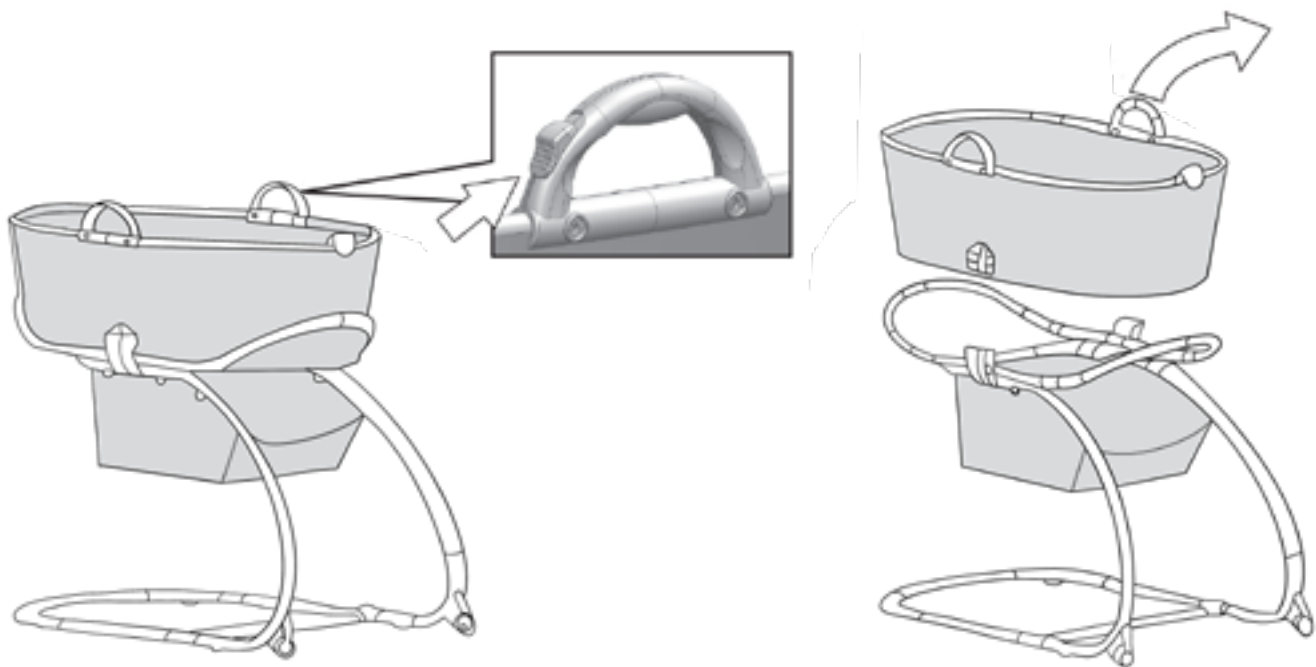

Using Moses Basket Separate from Frame

! WARNING:

- NEVER use near stairs or steps
- Child's movement can slide Moses Basket. NEVER place Moses Basket near edges of counter tops, table or other elevated surfaces.
- Your Moses Basket can roll over on soft surfaces and suffocate child.
- NEVER place Moses Basket on beds, sofas or other soft surfaces.
- NEVER use the Moses Basket as a means to transport an infant in a motor vehicle.

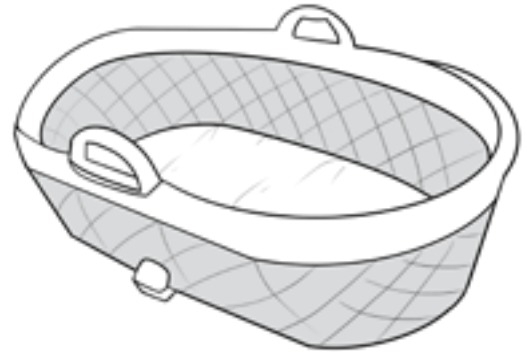

Moving Bassinet with wheels

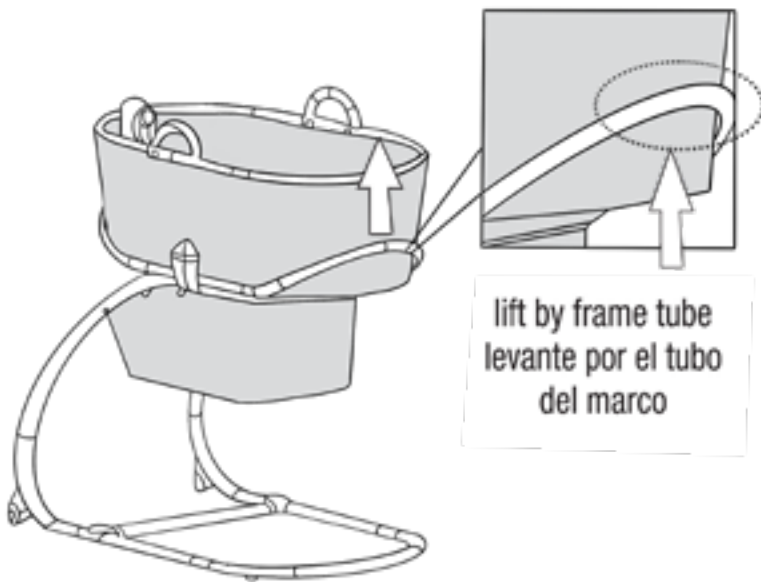

lift by frame tube
levante por el tubo
del marco

*DO NOT move bassinet or
carry moses basket with child in it.
*NO mueva el moisés ni transporte
la canasta con el niño dentro.

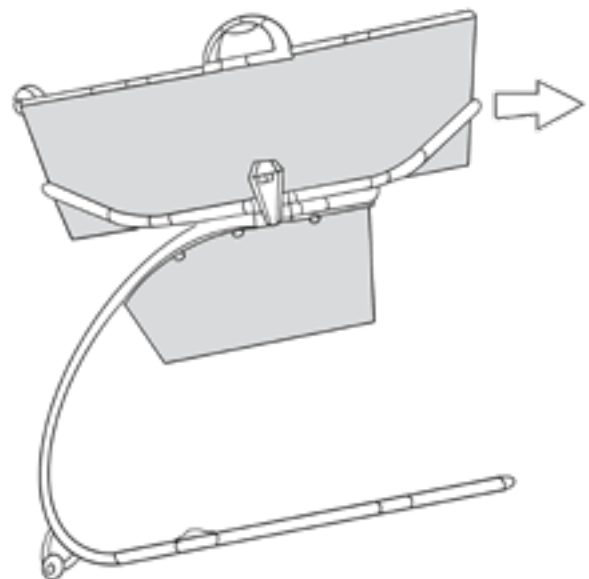

Care and Maintenance

- Bassinet Cover and Storage Basket: Hand wash in cold water, DO NOT bleach, hang to dry.
- Mattress Sheet: Machine washable in cold water, DO NOT belack, tumble dry low heat.
- Mattress Pad: Surface, wipe, air dry
- Bassinet frame, metal and plastic parts: surface wipe, air dry
- ALWAYS store product in a clean and dry place.
- Before each usage or assembly, inspect unit for damaged hardware, loose joints, missing parts or sharp edges.
NEVER use this product if there are any loose or missing fasteners, loose joints, broken parts, or torn mesh/fabric.

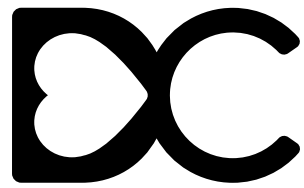

DELTACHILDREN

Delta Children's Products Corp.

114 West 26th Street
New York, NY 10001
646-435-8726
www.DeltaChildren.com