

# POWERGLYDE™ STROLLER

# Jeep®

## INSTRUCTION MANUAL

ADULT ASSEMBLY REQUIRED  
STYLES AND COLORS MAY VARY

### 11460



**▲ WARNING:  
CHOKING HAZARD**

Adult assembly required because of small parts. Keep assembly parts out of reach of children under 3 years.

Read all instructions BEFORE assembly and USE of product  
KEEP INSTRUCTIONS FOR FUTURE USE.

Customer Experience Center  
email: [gcs@DeltaChildren.com](mailto:gcs@DeltaChildren.com)



DELTA CHILDREN

[www.DeltaChildren.com](http://www.DeltaChildren.com)

DCP-IM-10062020

# Consumer Information



## WARNING

### Prevent serious injury from falls or sliding out:

- ALWAYS use the restraint system.
- Only children who have developed enough upper body control to sit without leaning forward can use the front seat in the upright position.
- NEVER leave child unattended.
- DO NOT use the storage bag to carry children.

### To prevent product from tipping over:

- DO NOT exceed the maximum storage weight limit of 3 lbs (1.36 kg) in the storage bag.
- DO NOT exceed the maximum storage weight limit of 3 lbs (1.36 kg) in the cup holder.
- DO NOT place additional items on this product, except as recommended in the instructions.

### To prevent injury:

- Make sure all body parts are clear of the stroller when folding and unfolding.
- DO NOT place hot liquids in the cup holder. Hot liquids can burn your child.

- Please read these instructions before assembly and use of this product.
- Adult assembly is required.
- Use only for a child who weighs less than 50 lbs (22.68 kg).
- Maximum weight limit for the storage bag is 3 lbs (1.36 kg).
- Maximum weight limit for the cup holder is 3 lbs (1.36 kg).
- Product features and decorations may vary from the photo.

### Care

- The plastic parts may be wiped clean using a mild cleaning solution and damp cloth. Hand wash fabric with damp cloth and air dry. Do not use bleach.
- To keep your stroller wheels from squeaking, use a silicone or graphite based lubricant.

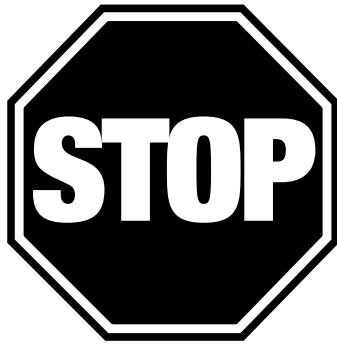

## **Before returning this product to the store! Let's see if we can assist you!**

- **Not sure how to assemble our product?**

Visit our site for easy to follow instructions along with some Tricks and Tips assembly videos <https://www.deltachildren.com/pages/instructions>

- **If you are missing a piece or have a damaged part**

Please contact our Consumer Experience Center for assistance at [gcs@DeltaChildren.com](mailto:gcs@DeltaChildren.com). To better assist you please have your Style# or Model# and Lot# available. This can be found on a white rectangular sticker on your product, on the registration card, and on the product's box.

- **In the event we do not have a replacement part available**

You may need to return your product to the retailer for an exchange or refund.

- **Warranty**

In order to protect your investment, don't forget to register your product. You may also wish to consider purchasing our extended warranty.

Visit <https://www.deltachildren.com/pages/extended-warranty> for more details.

- **Please note:**

“All Final”, “As Is” or Third Party/Liquidator sales are not covered under our Limited Manufacturer Warranty.

# DELTA CHILDREN

## LIMITED MANUFACTURER WARRANTY

This Delta product is warranted to be free from defects for a period of 90 days from the date of purchase under normal use. If a product is defective during this period, we will at our option repair or replace the defective part or product. This limited warranty extends only to the original retail purchaser and is valid only when supplied with proof of purchase, or if received as a gift, when the registration is on file with Delta.

This limited warranty does not cover the following:

- Products purchased as floor models or samples.
- Items purchased on an “as-is” basis, as a second hand product, or as a resale product.
- Items purchased at a Final sale, a “Going out of Business” sale, or a Liquidation sale. This limited warranty gives you specific legal rights and you may also have other rights which vary from state to state.

This limited warranty gives you specific legal rights and you may also have other rights which vary from state to state.

**TO REGISTER YOUR PRODUCT** for important safety alerts and updates to your product please visit [www.deltachildren.com](http://www.deltachildren.com)

**TO REPORT A PROBLEM**, please log on to [www.deltachildren.com](http://www.deltachildren.com) and click the Consumer Care Tab, or contact us by email at [gcs@DeltaChildren.com](mailto:gcs@DeltaChildren.com)

Date of Purchase: \_\_\_\_\_ (you should also keep your receipt)

## EXTENDED WARRANTY

### DON'T MISS YOUR CHANCE TO BE COVERED FOR ALL OF LIFE'S MISHAPS!

With Delta's Extended Warranty, you're covered for mechanical failure from normal use or if your item stops working due to normal wear and tear, plus all those unexpected surprises.

## 2 YEARS OF PROTECTION

**For Additional Information:**

**Simply visit our Website, register your product, and add the Extended Warranty**

**<https://www.deltachildren.com/pages/product-registration>**

Extended Warranty only available in the following States: Arkansas, Colorado, Delaware, District of Columbia, Georgia, Idaho, Illinois, Indiana, Iowa, Kansas, Kentucky, Louisiana, Maryland, Michigan, Mississippi, Missouri, Nebraska, Nevada, New Hampshire, New York, North Carolina, North Dakota, Pennsylvania, Rhode Island, South Dakota, Tennessee, Utah, West Virginia

# Parts

**IMPORTANT!** Please remove all parts from the package and identify them before assembly.

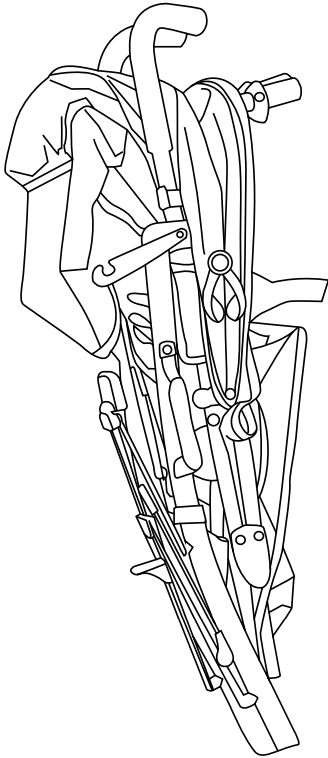

**Stroller**

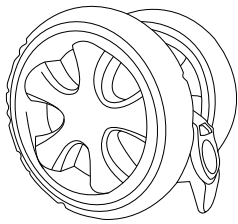

**Front Swivel  
Wheels X 2**

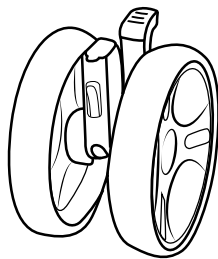

**Rear Non-Swivel  
Wheel x 2**

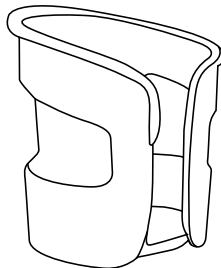

**Cup Holder**

# Assembly

**IMPORTANT!** Before assembly or each use, inspect this product for damaged hardware, loose joints, missing parts or sharp edges. **DO NOT** use if any parts are missing or broken. Contact manufacturer for replacement parts and instructions if needed. Never substitute parts.

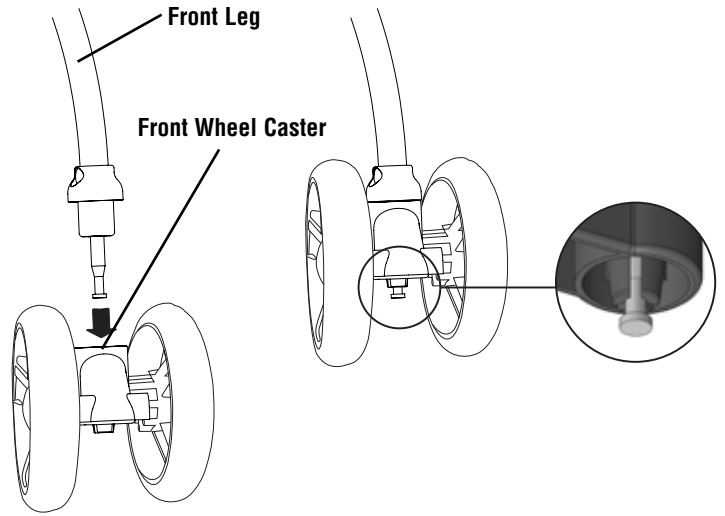

**1**

## Front Wheel Assembly

- Slide the front wheel caster onto a front leg. Make sure you hear a “click”.
- Pull on the front wheel assembly to make sure it is securely attached to the front leg.
- Repeat this procedure to attach the other front wheel assemblies.

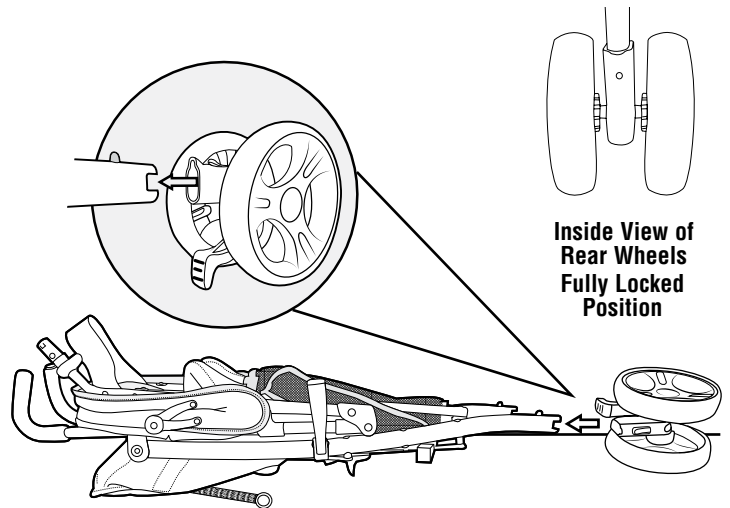

**2**

## Attaching Rear Non-Swivel Wheels

- Locate the legs on the rear of the stroller as illustrated.
- Use the Rear Non-Swivel Wheel and align with the stroller frame leg.
- Attach Rear Non-Swivel Wheel into the rear of the stroller frame leg, make sure the pin is aligned with the housing, until it “CLICKS” into a fully locked position. Make sure the wheel is in a fully locked position by pulling outward on the wheel.
- Repeat on opposite side.

# Setup and Use

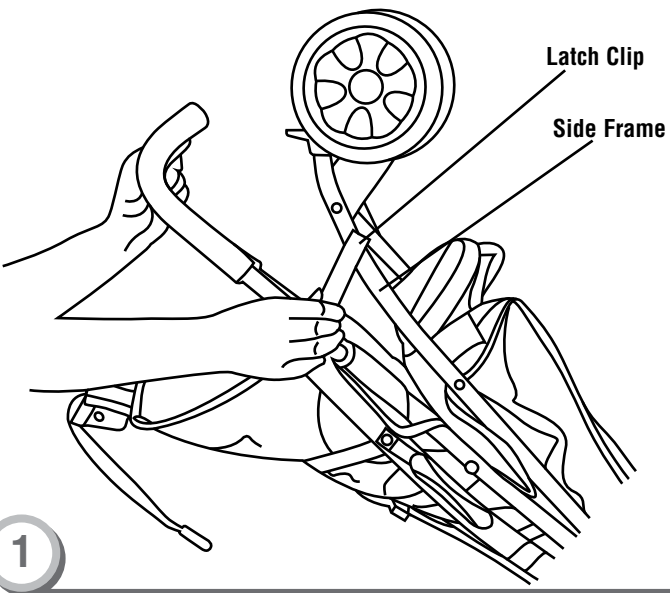

1

### To Unfold

- Locate the latch clip on the side of the stroller.
- Pull to release the latch clip on the side of the stroller.

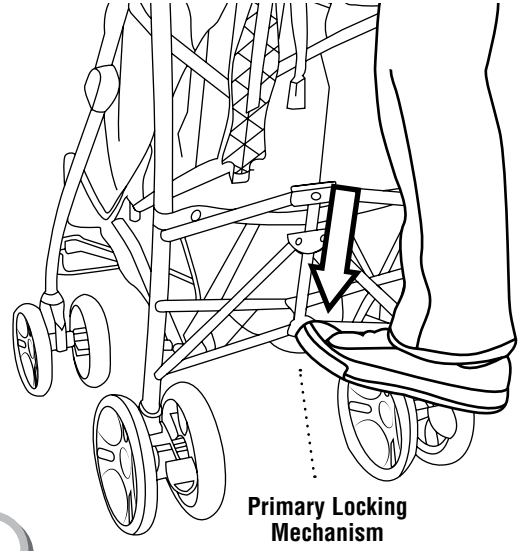

3

### Opening Stroller

- With your foot, push down on the **Primary Locking Mechanism** until it “clicks” into place.

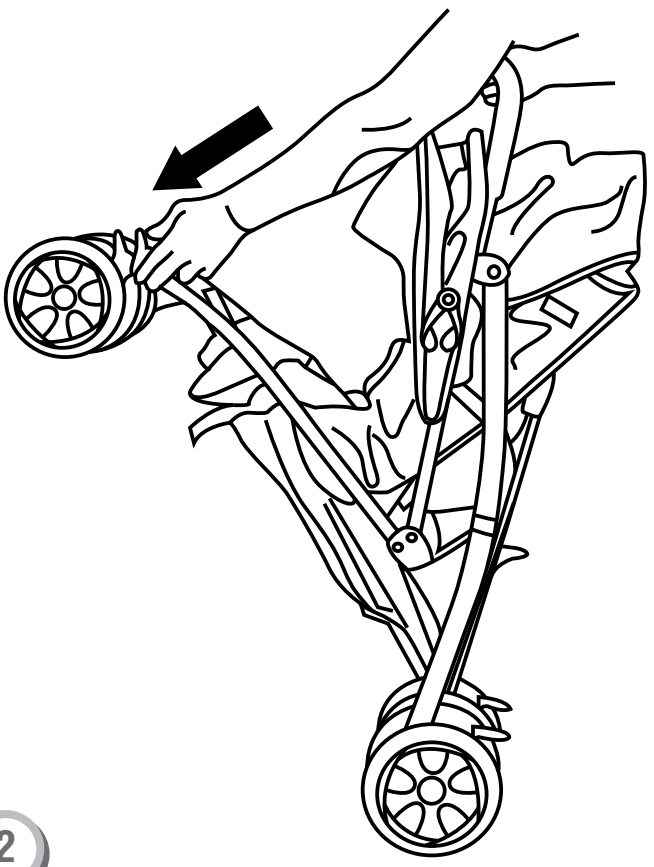

2

- Position the stroller upright on its rear wheels.
- Grasp a handle with one hand. With your other hand, push down on the front of the stroller to open.

# Setup and Use

## WARNING

### Prevent serious injury from falls or sliding out:

- ALWAYS use the restraint system.
- Only children who have developed enough upper body control to sit without leaning forward can use the front seat in the upright position.
- NEVER leave child unattended.
- DO NOT use the storage bag to carry children.

### To prevent product from tipping over:

- DO NOT exceed the maximum storage weight limit of 3 lbs (1.36 kg) in the storage bag.
- DO NOT exceed the maximum storage weight limit of 3 lbs (1.36 kg) in the cup holder.
- DO NOT place additional items on this product, except as recommended in the instructions.

### To prevent injury:

- Make sure all body parts are clear of the stroller when folding and unfolding.
- DO NOT place hot liquids in the cup holder. Hot liquids can burn your child.

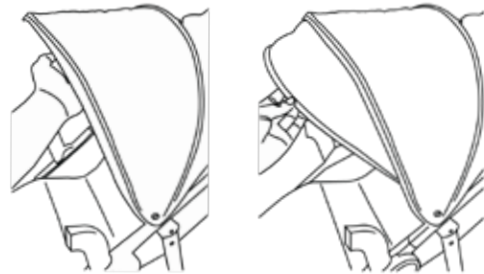
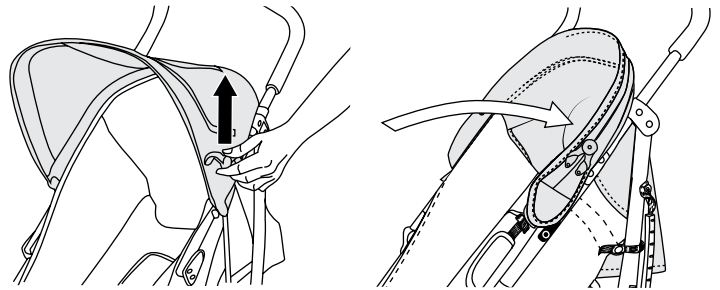

5

### Canopy and Sun Visor Adjustment

- The canopy and sun visor can be adjusted to an open or closed position.



Release Button

6

### Seat Recline Adjustment

- **To recline seat:** Push gray release buttons on **BOTH** sides of stroller at the same time and allow the seat to fully **RECLINE**.
- **To return upright:** Push seat upwards until it automatically “CLICKS” into place.

**WARNING:** Do not attempt to recline seat with child in stroller.

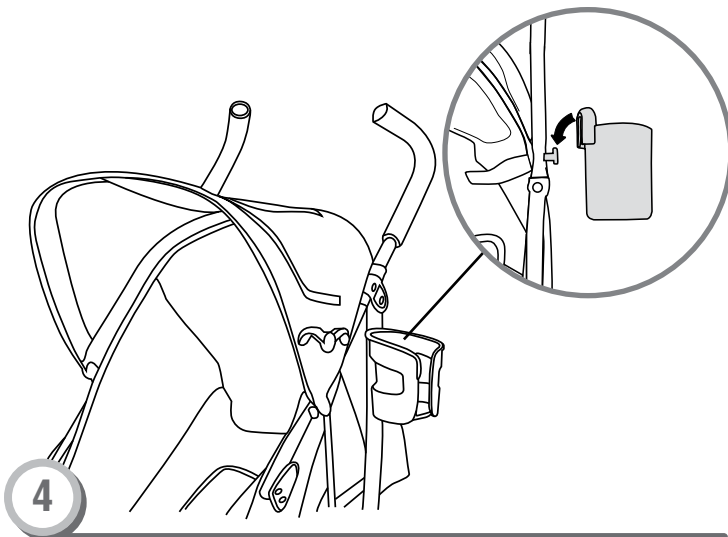

4

### Attaching Cup Holder

- Locate the knob on the side of the stroller.
- Fit the notch in the cup holder over the knob on the side rail and push down until you hear a “click”. Pull up on the cup holder to be sure it is secure.

# Setup and Use

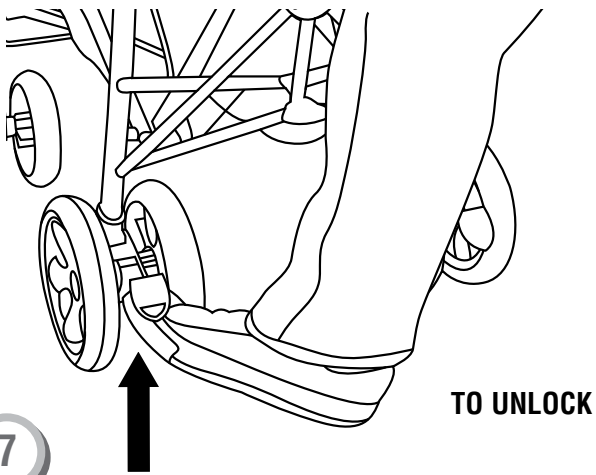
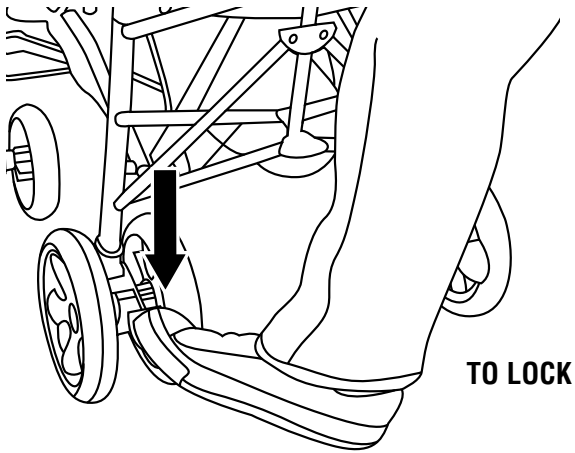

---

## Rear Wheel Brakes

### To lock the rear wheel brakes:

- Press **both** brake pedals down until they “**click**” into the locked position.  
**Make sure the brake pedals are pressed down completely.**
- Always set both brake pedals whenever you park the stroller.

### To unlock the rear wheel brakes:

- Lift both brake pedals until they “**click**” into the unlocked position.



# SECURING CHILD

## Before Placing your Child in Stroller:

Close Canopy. Press both brake pedals down until they “click” into the locked position.

**Make sure the brake pedals are pressed down completely.**

Always set both brake pedals when parking the stroller.

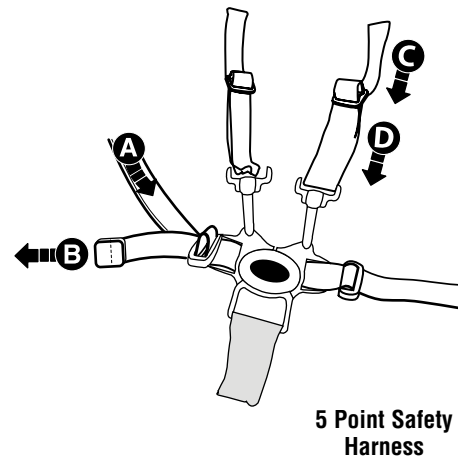
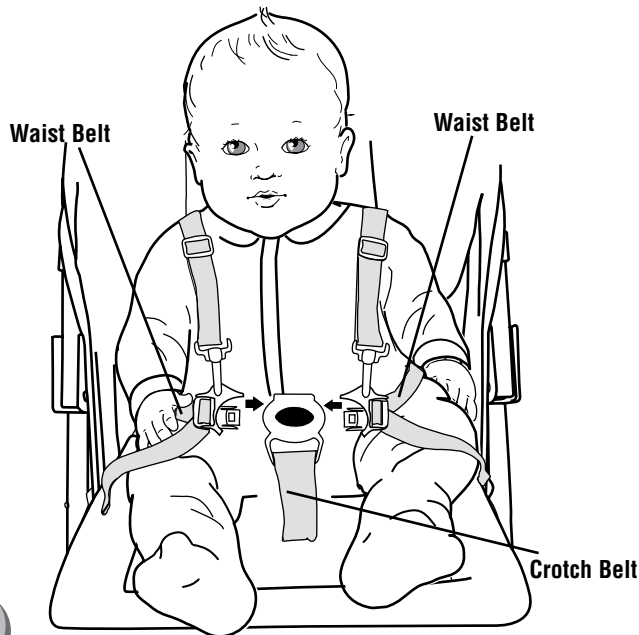

**TIGHTEN**

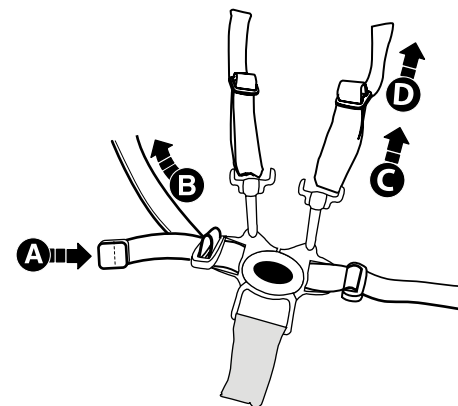

**LOOSEN**

1

## Securing Child

- Place your child in the stroller. Position the crotch belt between your child's legs.
- Pull shoulder straps over child's arm and shoulder and fasten **both** strap ends to the restraint system.
- Fasten **both** waist belts to the buckle on each side of the crotch belt. Make sure you hear a “click” on both sides.
- Check to be sure the restraint system is securely attached by pulling it away from your child. The restraint system should remain attached.

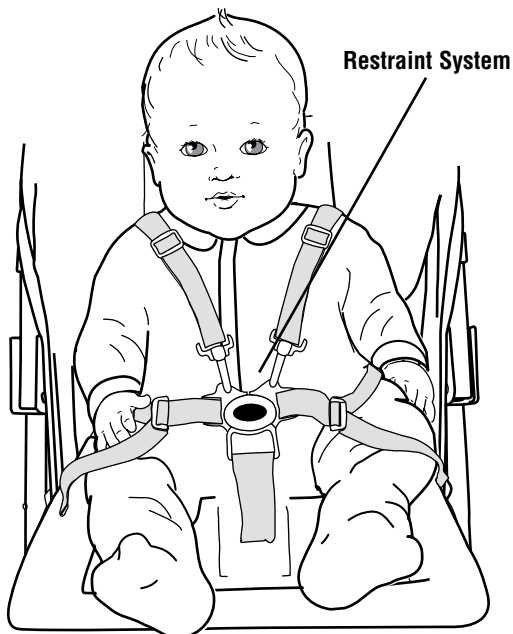

2

- Tighten each waist belt and shoulder strap so that the restraint system is snug against your child.

Please refer to the next section for instructions to tighten the waist belts.

3

## To tighten the waist belts and shoulder straps:

- Feed the anchored end of a waist belt up through the buckle to form a loop **A**. Pull the free end of the waist belt **B**.
- Repeat this procedure to tighten the other waist belt.
- Feed the top end of the shoulder strap through the plastic stay to form a loop **C**. Pull the bottom end down to tighten the strap **D**.
- Repeat this procedure to tighten the other shoulder strap.

## To loosen the waist belts and shoulder straps:

- Feed the free end of the waist belt up through the buckle to form a loop **A**. Enlarge the loop by pulling on the end of the loop toward the buckle. Pull the anchored end of the waist belt to shorten the free end of the waist belt **B**.
- Repeat this procedure to loosen the other waist belt.
- Feed the bottom end of the shoulder strap through the plastic stay to form a loop **C**. Pull the top end up to loosen the strap **D**.
- Repeat this procedure to loosen the other shoulder strap.

**Please note:** After adjusting the restraint system to fit your child, make sure you pull on it to be sure it is securely fastened.

# Storage

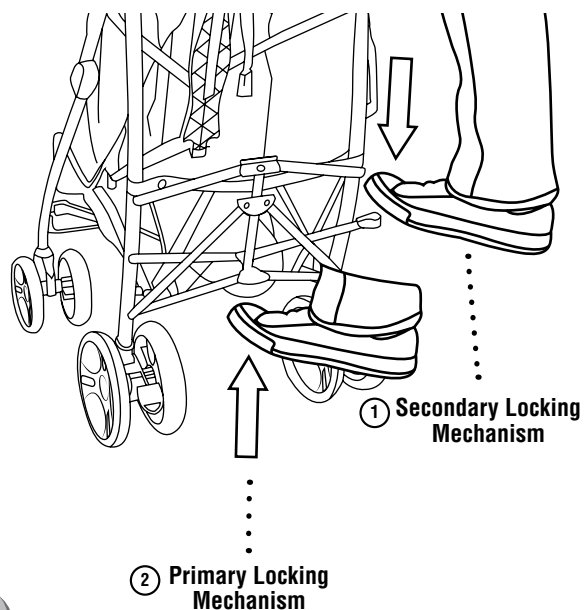

1

*Hint: Make sure canopy is in the closed position before folding the stroller.*

- 1. With your foot, step on the **Secondary Locking Mechanism**.
- 2. Then with your foot, lift up on the **Primary Locking Mechanism**.

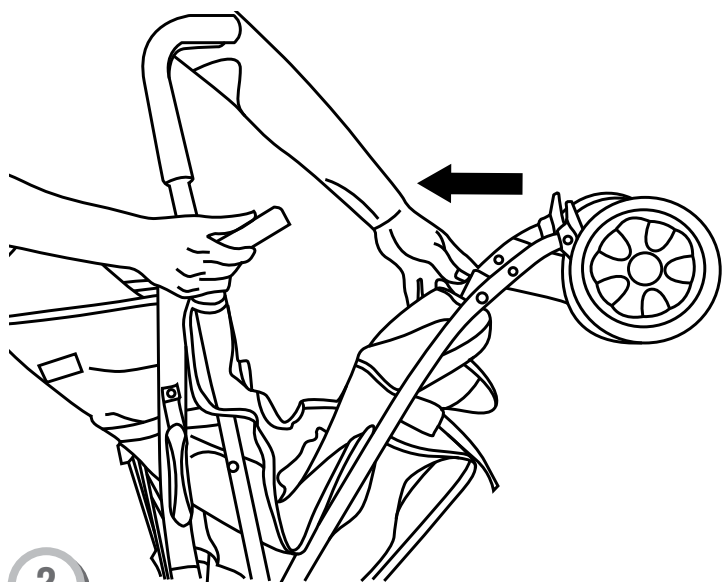

2

- Lift the front wheels toward the closed canopy.

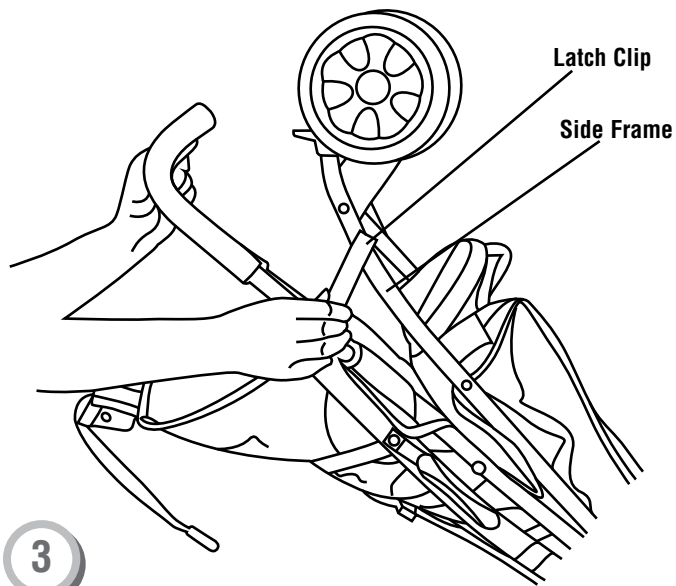

3

- Slide the latch clip onto the side frame to secure in the folded storage position.

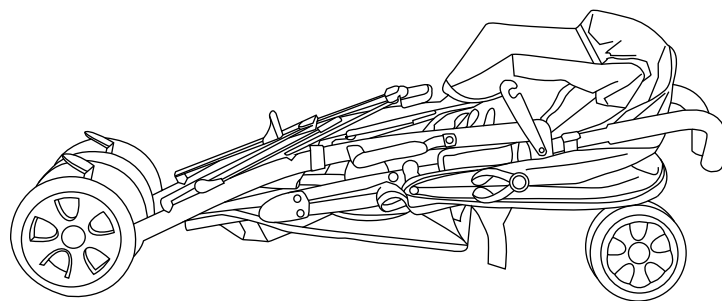

4

- Storage position.



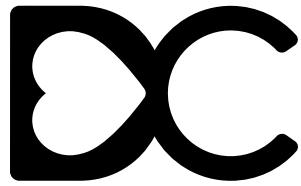

DELTACHILDREN

Delta Children's Products Corp.  
114 West 26<sup>th</sup> Street  
New York, NY 10001  
[gcs@DeltaChildren.com](mailto:gcs@DeltaChildren.com)  
[www.DeltaChildren.com](http://www.DeltaChildren.com)