

User Manual

HG H1000

SUPER SKUB



HG H1000

Table of Contents

User Manual	1
Introduction	3
1. Safety	4
1.1 Read the manual	4
1.2 Education	5
1.3 The most frequent causes of accidents.....	5
1.4 Preparation	5
1.5 Noise and vibration level	6
1.5.1 Vibration level	6
1.6 Operation	6
1.7 Maintenance	8
1.8 Transport & towing.....	9
1.9 Disposal & dismantling	9
2. Functions	10
2.1 Control panel	10
2.2 Machine's operating units	11
3. Precautions before starting.....	12
4. Driving.....	14
5. Maintenance	16
5.1 Overview of maintenance	16
5.2 Towing and tipping in case of engine failure	17
5.3 Maintenance Points	18
6. FAQ	23
7. Hydraulic program	24
8. Technical specifications.....	25
9. Warranty provisions	26
10. EU declaration of conformity	27

Introduction

The **HG H1000** is built for professional use in challenging urban environments.

The high-quality dumper is user and service friendly and has been well known for its longevity since 1970.

It is especially popular for work sites in cities among rental companies, landscapers, contractors, and demolition companies.

The HG dumper has total safety measures that ensure the highest safety standards for users while being able to load 1000 kg.

Find out more at:

www.hg-machines.com

- Minimal maintenance – built to last.
- Designed in Denmark since 1970.
- User-friendly and simple machine.
- High quality and low total cost of ownership.
- Excellent maneuverability and versatility.

Manufacturer:

HG Machines ApS

Vejlevej 15, 8722
Hedensted, Danmark

Bredgade 63A
1260 København K, Danmark

+45 75 89 12 44
hello@hg-machines.com
www.hg-machines.com

HG Poland Sp. z.o.o

Ul.Prosta 34 Lozienica
PI-72-100 Goleniów
NIP: PL 7010040430
+48 (91) 885 23 04

HG Bulk movement
made easy.

1. Safety

1.1 Read the manual

Please read this manual carefully and make sure that it is also read by other potential users of the machine. A hazardous situation may arise if the user is unaware of certain details about the machine.

If one of the warning labels is peeling off, worn or damaged, making the symbol illegible, replace the label.

WARNING!

Next to a piece of text in the manual indicates a risk of personal injury if the instructions are not observed.

WARNING!

Hot parts

Do not touch the engine or exhaust pipe during operation or immediately after the engine has stopped. Hot parts can cause serious burns.

WARNING!

Noise

We recommend the use of hearing protectors. Long-term exposure to noise damages your the hearing.

WARNING!

Poisonous gases

Do not let the engine run without

adequate ventilation and

never indoors, as the machine's exhaust poisonous carbon monoxide.



Manuals, parts lists and instructional videos can be found at www.hg-machines.com

WARNING!

Crushing risk

Do not touch the machine's moving parts. This applies to fingers and clothing as it may result in a loss of limbs.



WARNING!

Explosive liquid

Petrol is highly flammable and explosive, and may cause serious injury during filling.

We recommend stop the machine and keep it that you away from heat,

sparks and flames, remove any spills immediately and fill it with petrol outdoors.



WARNING!

Danger

When servicing and parking the machine, the engine must be switched off and ignition key removed.

1.2 Education

- Read the instructions carefully. Please familiarize yourself with all controls, switches etc. and how to use the equipment correctly.
- Operators of the motorized wheelbarrow must be over 18 years of age and have normal mental and physical capabilities. National or local legislation may prescribe a different age limit for persons authorized to operate the motorized wheelbarrow in a given situation.
- Remember that the operator is responsible for accidents or hazardous situations involving other people or their property.
- The operator should be properly instructed in the use of the motorized wheelbarrow. These instructions should focus on the following:
 - 1) The operator must be careful and concentrated when working with self-propelled machines.
 - 2) The operator must be aware of what is going on in front of/behind the vehicle, particularly in areas where people may be moving about.

1.3 The most frequent causes of accidents

1. Lack of overview

2. The operator's knowledge of the vehicle is insufficient
3. Too steep terrain conditions
4. Substrate does not have sufficient stability
5. The vehicle is used in insufficient space

1.4 Preparation

1. Do not wear loose-fitting clothing when operating the vehicle.
2. Store fuel in canisters approved for this purpose and keep out of reach of children and unauthorized personnel.
3. Fuel fill is only permitted outdoors. Smoking is prohibited during filling.
4. Fill fuel before starting the engine. Never remove the fuel tank cover or fill fuel while the engine is running or hot.
5. In case of fuel spills, do not attempt to start the engine, but remove the motorized wheelbarrow from the location of the spill to avoid igniting it.
6. If you spill fuel on the exhaust pipe or the engine, wait until the fuel has evaporated due to the risk of fire.

7. If petrol or oil comes into contact with your skin, wash your skin thoroughly with soap.
8. Inhalation of fuel vapors or oil mists is harmful to health.
9. Ingestion of fuel or oil is life-threatening.

1.5 Noise and vibration level

When tipping with an empty tray and maximum revolutions, the highest energy-equivalent sound pressure level at the operator's position has been measured at 88 dB (A) in accordance with ISO 6396.

Under simulated operating conditions involving combined driving and tipping, the highest energy-equivalent sound pressure level at the operator's position has been measured at 87 dB (A) in accordance with ISO 6396.



The uncertainty of the measurements stated above is ± 2 dB. HG recommends the use of hearing protectors, even though the noise level is below the limit where hearing protection is required.

1.5.1 Vibration level

When tipping with an empty tray and maximum revolutions, the maximum weighted arm-hand

vibration level at the operator's position has been measured in accordance with ISO 1032 at:

$a_{hv} = 5.0 \text{ m/s}^2$.

Under simulated operating conditions involving combined driving and tipping, the maximum weighted arm-hand vibration level at the operator's position has been measured in accordance with ISO 1032 at:

$a_{hv} = 3.0 \text{ m/s}^2$.

The uncertainty of the measurements stated above is $\pm 25\%$.

1.6 Operation

WARNING!

Failure to observe the following operating instructions may result in personal injury:

- When operating the machine indoors, make sure there is an effective extraction system in place in accordance with the applicable on-site rules and instructions.
- Do not let the engine run in small confined spaces where dangerous carbon monoxide may accumulate.
- Inhalation of carbon monoxide may cause poisoning and death.
- Do not use the machine in areas with combustible dust or explosive gases, or

where the exhaust pipe may come into contact with combustible material.

- Operate the motorised wheelbarrow only in daylight or good artificial light, whenever possible.

- Do not operate the motorised wheelbarrow at insufficient ceiling heights.



- Do not operate the machine down slopes exceeding 5° degrees.

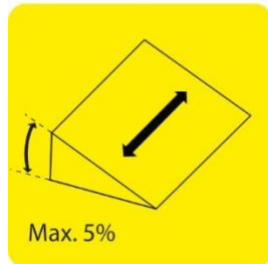

- Do not operate the machine across slopes exceeding: 10° degrees on hard surfaces

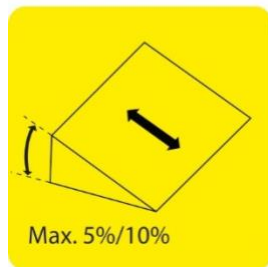

such as concrete and asphalt.
5° degrees on firm surfaces such as gravel and grass.

- If the machine tips over, let go of the machine and step away from it. Never attempt to keep the machine steady.

- Do not operate and unload the motorised wheelbarrow near excavations and unstable edges.



- Do not use the tipping function to unload a frozen load or a load of extremely sticky material, such as clay. The machine may tip over.

- Avoid driving on soft, loose or uneven surfaces. This involves a risk of the operator being subjected to inappropriate loads.

- Remove the ignition key when leaving the motorised wheelbarrow.

- Always stop the engine before carrying out any service or repair.

- Stop the engine and leave it to cool before filling it with fuel.

- Do not touch the engine or the exhaust pipe when the engine is running.

- The machine may only be used to transport materials.

- When reversing, the operator must pay particular attention to uneven areas and obstacles that the operator may fall over or drive into.



- When lowering the tray, the operator must pay close attention to other people in the vicinity of the machine to make sure that they do not suffer crushing injuries.



- The area around the machine must be kept clean to avoid fall accidents.

- that the radiator grille and the cooling fins on the engine are free of dirt
- that there are no engine oil spills near the filler cap
- that the motorized wheelbarrow stands still, when the forward handle is not activated
- that the safety plate triggers forward movement when activated
- that the tires have the right pressure and are lubricated.

1.7 Maintenance

Always perform a visual inspection and control of the machine before each use to make sure:

- that there are no leaks in hoses, the tank etc. in the hydraulic system
- that there are no leaks in hoses, the tank etc. in the fuel system
- that bolts, nuts etc. are securely tightened



WARNING!

Always mount the safety fittings for the tipping cylinder before starting the inspection work.

1.8 Transport & towing

To tow the machine without starting the engine, activate the coasting button on the left-hand side. This will disengage the drive wheels, allowing the machine to be moved.

When lifting the machine, use the three lifting points in front and on the control panel.



Ensure sufficient stability during lifting to prevent disconnection.

The machine may ONLY be lifted when the tray is empty.



The machine may only be transported using a vehicle with sufficient headroom as there is a risk of serious injury and damage to the operator,

machine and transport vehicle.

During transport, make sure that the machine is securely fastened to the tray or in a cargo compartment in accordance with the applicable regulations.

1.9 Disposal & dismantling

When, many years from now, the motorized wheelbarrow is worn out and must be disposed of, Hedensted Gruppen will carry out the dismantling work by arrangement, as this work must be carried out in an environmentally friendly manner. During the dismantling process, the parts are sorted according to type of material. This means that steel parts are classed as steel, rubber seals as rubber and so forth. The various materials are then disposed of according to the regulations in force at any time.

2. Functions

2.1 Control panel



1. Lever for tipping the tray.

Push it up to tip the tray and down to lower the tray.

2. Choke hand lever.

Push the lever down to activate the choke.

3. Coasting button.

Turn the button counter-clockwise to disengage the wheels, so the machine can be pushed.

To engage the wheels again, press and hold down the button while turning it clockwise.

4. Emergency stop/safety plate.

When the safety plate is pressed, the machine moves forward, preventing the operator from being trapped.

5. Reverse hand lever.

Push the lever up towards the handle bar. The higher up you push the lever, the higher the speed.

6. Throttle hand lever (engine revolutions).

Push the lever down to activate the throttle.

7. Forward hand lever.

Push the lever up towards the handle bar. The higher up you push the lever, the higher the speed.

2.2 Machine's operating units



8) Petrol filling – 92 octane unleaded.

9) Sight glass for checking hydraulic oil level.

10) Tip protection for the vessel's hydraulic cylinder.

11) Control and engine oil fill.

12) Hydraulic filter with service indicator.

13) Key start.

Used to start and stop the engine.

14) Recoil start.

Used to start in the event of a power failure.

15) Hydraulic oil fill.

3. Precautions before starting

Check engine condition

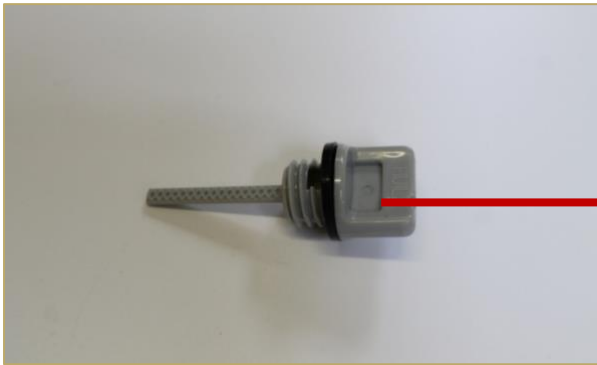

Oil must be visible on the dipstick or top up with type SAE 15W-40 engine oil, if necessary.

Check the hydraulic oil level



WARNING! Fit the tipping protection.

Top up with type Q8 Handel 46 hydraulic oil or similar, if necessary.

Petrol fill

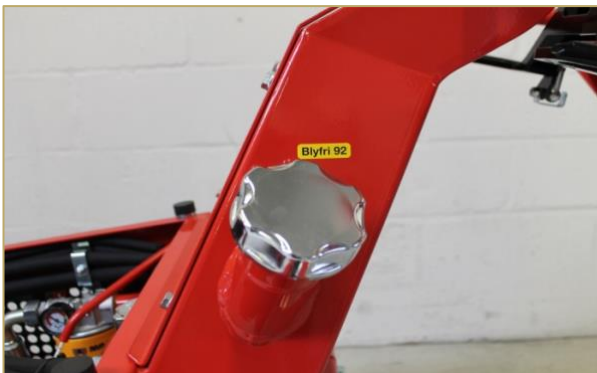

Use unleaded petrol, 92 octane or higher.

WARNING!

Petrol is a highly flammable and explosive liquid. Leave the machine to cool for at least 10 min. before filling and keep it away from ignition sources.

Seek medical attention if you have inhaled vapors or swallowed petrol.



Tyre pressure and retightening:



All tyres must have the right air pressure in order to ensure optimum ergonomics.

Tyre pressure, drive wheel: 85 psi/8.5 bar

Tyre pressure, guide wheels: 71 psi/7.1 bar



Retighten the wheels once a week.

Torque: 100 Nm.

Service indicator on hydraulic filter

The indicator gauge on the hydraulic filter indicates whether the filter needs servicing or replacing.

Apply full throttle, and check the indicator. If the indicator is in the red area, the machine needs servicing.



Safety plate test



Pressing the safety plate should move the machine forward, preventing the operator from being trapped during reverse.

Check the plate when the machine is switched on.

Press the plate, and check that the machine is moving forward.

The system must be undamaged and be able to move effortlessly.

4. Driving



Start the machine by activating the choke when the engine is cold and then turning the ignition key clockwise. When the engine is running, release the key and adjust the choke until the engine is running smoothly. Adjust the throttle to the desired engine revolutions.

The choke is deactivated after a while. If the engine is warm, it is not necessary to use the choke.



Place both hands on the handle bar so that your fingers can reach the forward handle. Pull up the hand lever on the right to move the machine forward and release to stop. Pull up the hand lever on the left to reverse.

Before reversing, check for people and obstacles behind you.

The direction of the machine is controlled by pulling the handle bar to the right or left while the machine is moving forward. Do not attempt to control the direction, while the machine is standing still as this will put considerable strain on the body.

WARNING!

The machine should stop immediately and come to a complete standstill when releasing the forward and reverse handles. If the machine 'crawls' slightly, it must be taken out of service immediately, and the fault repaired.



To tip the tray, push the tipping lever up with your left hand, while keeping your right hand on the handle bar. Use the lever to adjust the speed: the more you push it, the greater the speed.

Before lowering the tray, the operator must check that no people are within the machine's range. Lower the tray by pushing down the

tipping lever with your left hand, while keeping your right hand on the handle bar. Wait until the tray is lowered completely, and place both hands on the handle bar before pulling the forward handle.

WARNING!

If the machine tips over, let go of the machine and step away from it. Never attempt to keep the machine steady.

Before leaving the machine, make sure the tray is lowered completely, the throttle hand lever is in the uppermost position and the engine is switched off with the key. Remove the key from the machine before leaving the machine for an extended period of time.

5. Maintenance

5.1 Overview of maintenance

Activity		For each xx operating hours					
		Daily	3 m.	20 hours	50 hours	100 hours	300 hours
Check	Hydraulic oil level	x					
	Engine oil level	x					
	Air filter (in a very dusty environment)	x					
	Wheel air pressure	x					
	Function of the safety plate	x					
	Leaks	x					
	Coasting valve		x				
	Bolts and nuts are tightened		x				
Adjustment	Spark plug					x	
	Release button		x				
	Safety plate		x				
Lubrication	Pendular suspension		x				
	Wheel		x				
Re-tightening	Wheel		x				
Cleaning	Spark plug					x	
	Sediment in carburettor					x	
	Air filter		x			x	
Replacement	Air filter						x
	Engine oil			First		x	
	Engine oil filter			First		x	
	Hydraulic filter			First		x	
	Hydraulic oil			First		x	
	Warning signs as needed		x				
	Spark plug						x

First = replaced when the machine has run 20 hours.

Components must be checked as recommended by the supplier. Hedensted Gruppen requires that a comprehensive service inspection of the machine be carried out by an authorized service technician at least once a year. Safety features such as the release button and safety plate must be inspected every three months. All maintenance must be carried out by a trained mechanic, service technician or similar professional.

5.2 Towing and tipping in case of engine failure



The coasting button is used to disengage the drive wheels, allowing the motorized wheelbarrow to be moved when the engine is off. Turn the button counter-clockwise to disengage. Push the button and turn clockwise to re-engage the engine.

WARNING!

The machine's parking brake cannot be operated when disengaged. Place a suitable object on both sides of the wheels when leaving the machine.



In case of an engine fault, the tray can be tipped manually.

This task requires two people.

There must be one person on each side of the machine's

handle bar, with one foot placed in front of the guide wheels. Push up the tipping lever while simultaneously pushing up the tray.



While one person holds up the tray, the other mounts the safety fitting on the hydraulic cylinder.

WARNING!

There is now a vacuum in the cylinder.

With the engine running, activate the tipping lever to refill before removing the safety fitting.

5.3 Maintenance Points



Safety fittings

Mount the safety fitting on the tipping cylinder before carrying out maintenance. Loosen the two finger screws, and remove the fitting from the inside of the machine. Remove the large finger screw, and fold out the fitting. Place it over the cylinder rod, and screw on the finger screw to lock.



Draining hydraulic oil

Place a suitable container under the hydraulic oil tank and remove the plug. The tank must be able to hold 17 liters. Clean and refit the plug when the oil has been drained from the tank.

WARNING!

Be careful as the oil may be very hot!



Replacing the hydraulic filter

Place a suitable container under the machine near the filter. Loosen the filter, and unscrew it. Lubricate the gasket on the new filter with oil, and screw it on. Tighten the filter firmly by hand.



Hydraulic oil fill

Using a clean oil can, add approximately 17 liters of type Q8 Handel 46 hydraulic oil or similar. Check the oil level in the sight glass on the left-hand side of the machine.

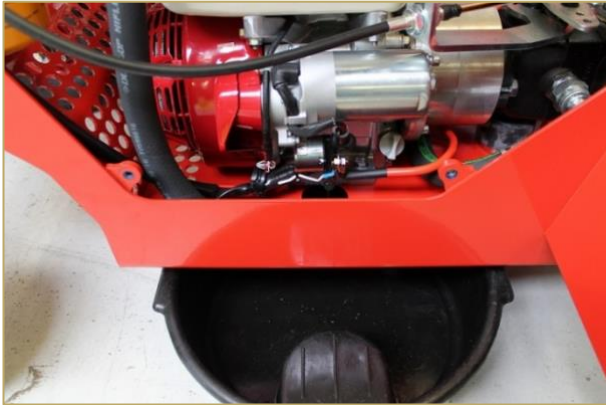

Changing the engine oil

Place a suitable container under the hydraulic oil tank and remove the plug. Clean the plug, replace the gasket and refit the plug when the oil has been drained from the tank.

Using a clean oil can, add approximately 0.6 liters of type SAE 15W-40 engine oil. The oil level must reach the top of the thread. Check the oil level with the dipstick.

WARNING!

Be careful as the oil may be very hot!



Sediment in the carburetor

Place a suitable container under the machine near the carburetor. Close the fuel tap, and remove the drain plug on the side of the float

bowl. Replace the gasket and refit the plug. Open the fuel tap again.



Air filter

Remove the cover and filter by loosening the two finger nuts.

Clean the foam filter and paper filter with compressed air or replace them. Refit the foam filter around the paper filter and then mount it on the engine with the metal nut. Mount the cover with the plastic nut.



Replacement of spark plugs

Remove the spark plug with a 21 mm spanner by turning counter-clockwise. Clean the spark plug and adjust the electrode distance to 0.70-0.80 mm. Replace the spark plug if necessary. Always screw on the spark plug by hand. If a new spark plug is fitted, tighten it another half

turn to seal the gasket. If a used spark plug is fitted, only tighten it another one-eighth to one-quarter turn.



Lubrication

Standard high-pressure grease can be used for lubrication.

Lubricating nipples are mounted on:

- Guide wheel suspension, rocker shaft.
- Guide wheel, pivot shaft.
- Guide wheel, shaft.



Wheel air pressure

All tyres must have the right air pressure in order to ensure optimum ergonomics.

Tyre pressure, drive wheel: 85 psi/8.5 bar

Tyre pressure, guide wheels: 71 psi/7.1 bar.



Retightening the wheels

Retighten the wheels once a week.

Tightening torque: 100 Nm.

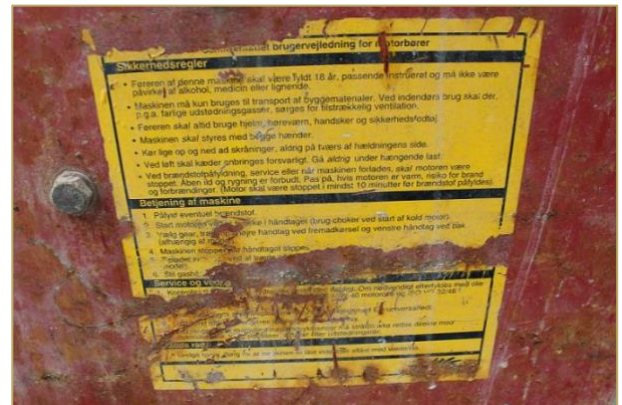

Replacement of signs

Replace warning and safety signs if they are illegible.

Adjusting the zero point

The machine's zero point ensures that the machine stands still when the forward/reverse handle is not activated.

Adjust the zero point if the machine crawls backwards and forwards slightly when the handle is not activated. The machine must be

warm and stand on a level floor when carrying out the adjustment.



Serial no. 280100-001-2016 and onwards

Loosen the lock nut (1) on the underside of the eccentric bolt (2) with a 13 mm spanner. Turn the eccentric bolt (2) to the right or left until the machine has come to a complete stop. Then tighten the lock nut (1) again.

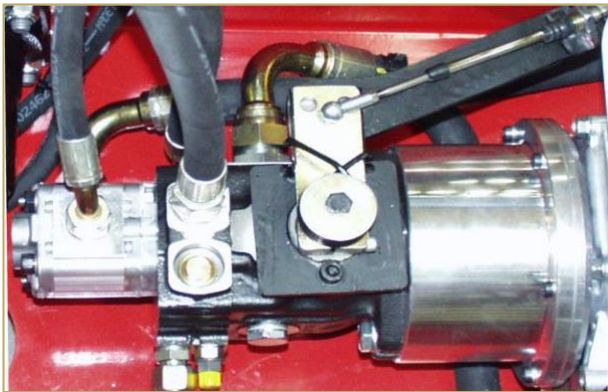

After serial no. 050503-00 to 280100-001-2016

Loosen the bolt (1) with a 6 mm Allen key. Adjust the cable fitting (2) by turning it around the center until the machine has come to a complete stop. Tighten the bolt (1) again.

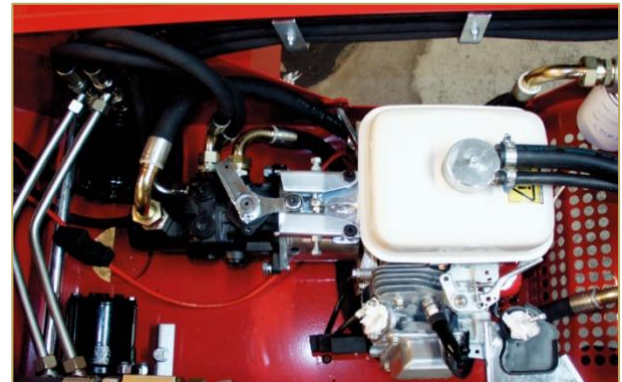

Adjustment - before serial no. 050503-00

Loosen the nuts (1) with a 13 mm spanner. Adjust the nuts (2) until the machine has come to a complete stop. Tighten the nuts (1) again.

When the adjustment has been performed, test the machine on sloping terrain to check that it comes to a complete standstill.

Adjustment of safety plate

Pressing the safety plate should move the machine forward, preventing the operator from being trapped during reverse. When the machine has moved away from the operator, it should stop.



Loosen the two lock nuts with a 13 mm spanner. Remove the cotter bolt from one angle joint, and remove the head from the ball. Now turn the angle head in or out as required.

Mount the angle head and the cotter bolt, and tighten the lock nut. Check that the plate, tubular pins, bolts and nuts holding the shafts and connections are undamaged. Use your thigh to test if the machine moves forward when the plate is activated. The machine should move before your thigh touches the round handle bar.

Coasting valve

When the valve is set to coasting, the machine's drive wheels should not be able to rotate and the machine should not move.



Check that the valve button is not damaged.

Adjusting the tipping lever

The stop on the tipping lever reduces the speed of the lowering function to prevent the hose burst check valve from being activated.



Adjust the stop so that the tray is lowered at a steady speed, but the engine does not sound strained.

6. FAQ

Problem	Possible cause	Solution
The machine does not start.	The oil monitor has been activated.	Check the oil level and refill.
The machine does not pull.	The coasting valve has been activated.	Push and hold the coasting button and turn clockwise to lock.
The machine feels heavy when operated.	The air pressure in the guide wheel is too low.	Inflate the wheel up to the maximum pressure.
The engine stops when the tray is lowered.	The hose burst check valve is activated when the tray is lowered.	Adjust the stop on the tipping lever to reduce the lowering speed.
The machine crawls when the engine is idling.	The drive system's release button is not adjusted correctly.	Adjust the release button's zero point.
The hydraulic system lacks power.	The centrifugal clutch is worn.	Change the trays in the centrifugal clutch.
The engine is difficult to start, or it stops.	Water in the petrol.	Replace the petrol, and remove any sediment in the carburettor.
The engine is difficult to start.	The spark plug is worn or defective.	Replace the spark plug.
The machine does not drive straight ahead.	Guide wheels or wheel suspension is damaged and does not travel straight.	Replace the wheels or suspension.

7. Hydraulic program

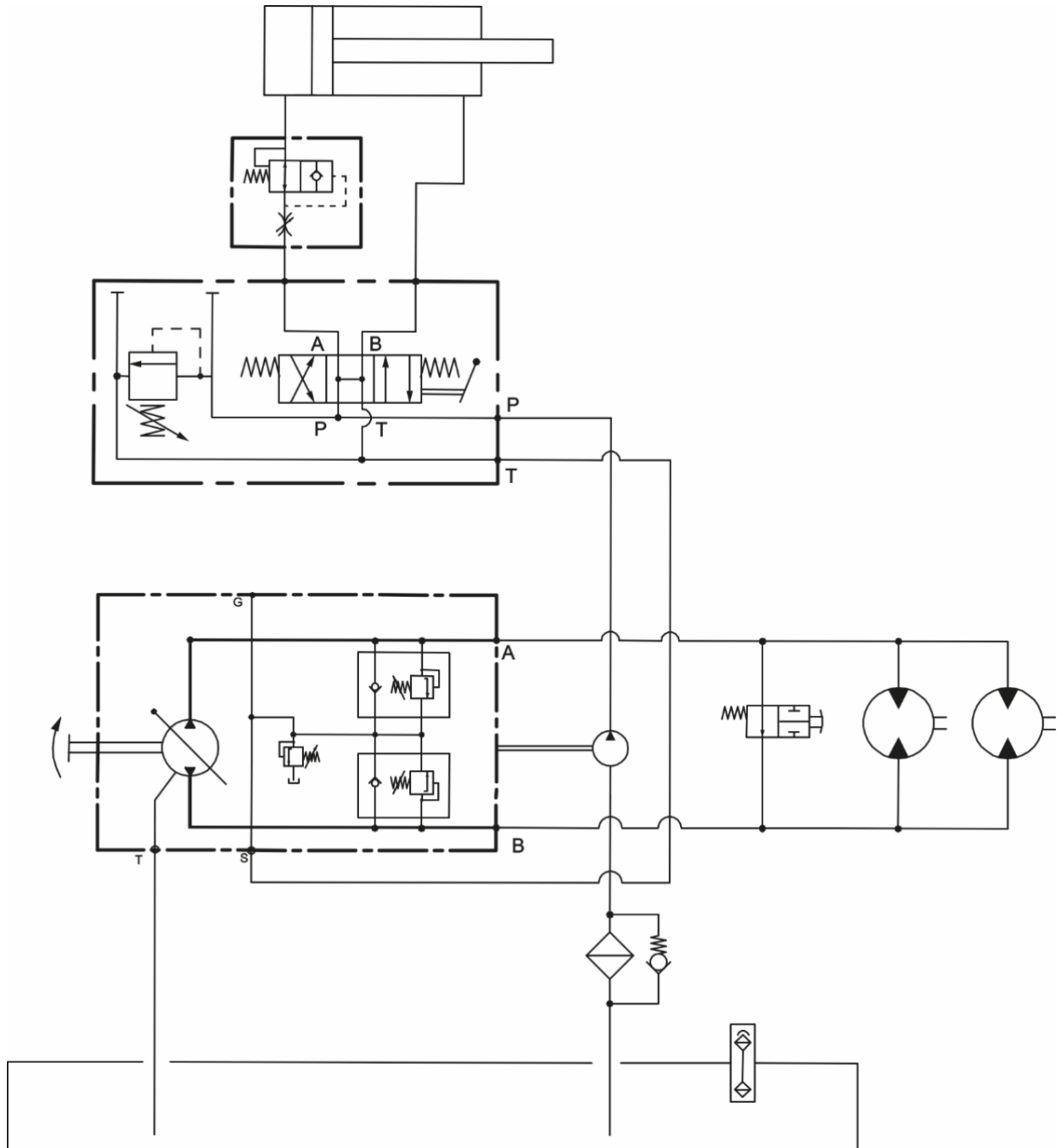

8. Technical specifications

Specifications	
Width	850 mm
Length	2050 mm
Height	1080 mm
Own weight	295 kg
Content in liters	400 L
Content in kg	1000 kg
Reading height	60 cm
Driving speed	0-6 km/t
Reverse speed	0-3 km/t
Engine	
Type	Honda GX200 Stage V – Electric start Centrifugal clutch before cold start Transmission, stepless hydrostatic forward/reverse
Performance	6.5 HP
Clutch	Centrifugal
Petrol tank	3.6-litre petrol – 92 Octane, unleaded
Other things	
Leave function	Hydraulic tip with three-way manual valve. Tip cylinder, double acting
Hydraulic tank:	17 liters Handel 46
Drag wheels	LP 190 x 8 x 6 ply
Forked wheels	4.00-4
Sound pressure:	Lpa, eq = 88 dB(A) maximum (Measured at tip with empty box and maximum revolutions) Lpa, eq = 87 dB(A) simulated operation (Measured by simulated operating conditions between driving and tipping) Uncertainty in the above measurements is +/- 2 dB
Vibrations	Weighted arm/hand level - 5 m/s ² max. (Measured at tip with empty box and maximum revolutions) Weighted arm/hand level - 3 m/s ² simulated operation. (Measures for simulating operating conditions between driving and tipping) The uncertainty of the above measurements is +/- 25%

9. Warranty provisions

Warranty period

HG Machines provides a guarantee for 12 months. The warranty period begins on the date of delivery.

The warranty includes

Components that must be replaced or repaired due to material or manufacturing defects.

The warranty does not cover wear and consumable parts such as:

Tires and hydraulic oil

The manufacturer's warranty expires if

The machine is used incorrectly.

The machine is used without following the instruction manual and the safety regulations.

The machine is not maintained according to the instructions or outdated spare parts are used.

The machine is used after a fault has been detected, so this results in a more expensive repair than the original fault.

When converting or connecting other electrical parts.

The owner's own insurance should cover

Fire, burglary, theft and vandalism.

Water and frost damage.

Damage caused by wind and weather.

The manufacturer's warranty does not apply in these cases

The manufacturer's approval of a claim for compensation requires that the defective part is shown to the manufacturer or its representative within two weeks after the damage has occurred. Owner rights to the damaged part(s) are transferred to the supplier of the new parts.

According to the warranty only replaces components. It therefore does not cover

Shipping costs.

Costs related to waiting time, machine owner working time and travel costs.

Operating losses and other subsequent costs.

Other things

Prior to repair under warranty, the manufacturer must be contacted to agree the procedure. If the repair has been initiated or completed, it is too late to claim the warranty.

These warranty provisions can only be changed through a separate agreement.

10. EU declaration of conformity

HG Machines ApS
Vejlevej 15
DK-8722 Hedensted
Tel. (+45) 75 89 12 44
www.hg-machines.com

Hedensted, 15. februar 2023

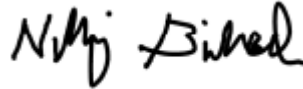

Nikolaj Birkerod
Direktør

hereby declares that:

Super Skub model HYDRA with recoil start
Type number 280121
Super Skub model HYDRA with electric start
Type number 280125
Super Skub model HYDRA with electric start
Type number 280100

is in accordance with:

- Machinery Directive 2006/42/EC
- EMC Directive 2014/30/EU
- Directive on machines for outdoor use - 2000/14/EC

using the following harmonized standards:

- DS EN ISO 12100:2011
- DS EN ISO 13857:2008