

## Water Feeders – Mechanical

### Series 47/47-2 Mechanical Water Feeders/Low Water Cut-Offs



- For steam and hot water boilers with **cold water feed**
- Continuous maintenance of **minimum safe water level**, independent of electrical service
- Proportional feed action
- Quick hook-up fittings provided
- Quick-change replaceable cartridge valve and strainer
- Optional features
  - No. 2 switch
  - Manual reset
- Model 47 can be field upgraded with a No. 2 switch to add low water cut-off function
- Maximum water supply pressure 150 psi (10.5 kg/cm<sup>2</sup>)
- Maximum inlet water temperature 120°F (49°C)
- Maximum boiler pressure 25 psi (1.8 kg/cm<sup>2</sup>)



Series 47

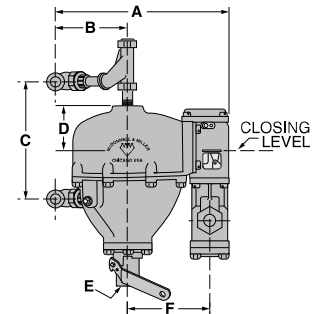

Series 47-2

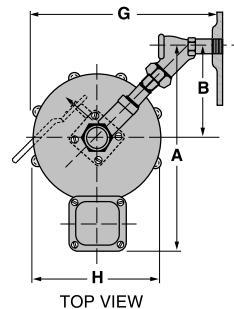
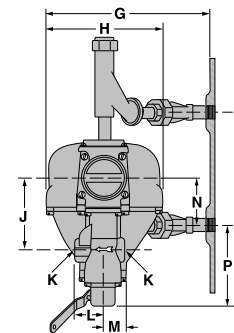
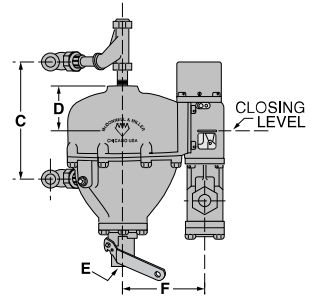

### Electrical Ratings

Voltage	Motor Switch Rating (Amperes)		Pilot Duty
	Full Load	Locked Rotor	
120 VAC	10.2	61.2	125 VA at 120 or 240 VAC 60 Hz
240 VAC	5.1	30.6	

### Dimensions, in. (mm)

A	B	C	D	E NPT	F	G
11 <sup>7</sup> / <sub>8</sub> (302)	5 <sup>1</sup> / <sub>4</sub> (133)	7 <sup>3</sup> / <sub>8</sub> (187) min. 14 (356) max.	2 <sup>5</sup> / <sub>8</sub> (67)	<sup>3</sup> / <sub>4</sub>	5 <sup>1</sup> / <sub>8</sub> (130)	10 <sup>5</sup> / <sub>8</sub> (270)
H	J	K NPT	L	M	N	P
7 <sup>5</sup> / <sub>16</sub> (186)	4 <sup>5</sup> / <sub>8</sub> (117)	<sup>1</sup> / <sub>2</sub>	1 <sup>29</sup> / <sub>32</sub> (58.4)	1 <sup>13</sup> / <sub>32</sub> (35.7)	3 (76)	5 <sup>5</sup> / <sub>16</sub> (135)

## Water Feeders – Mechanical

### Series 47 (continued) Mechanical Water Feeders

#### Capacities

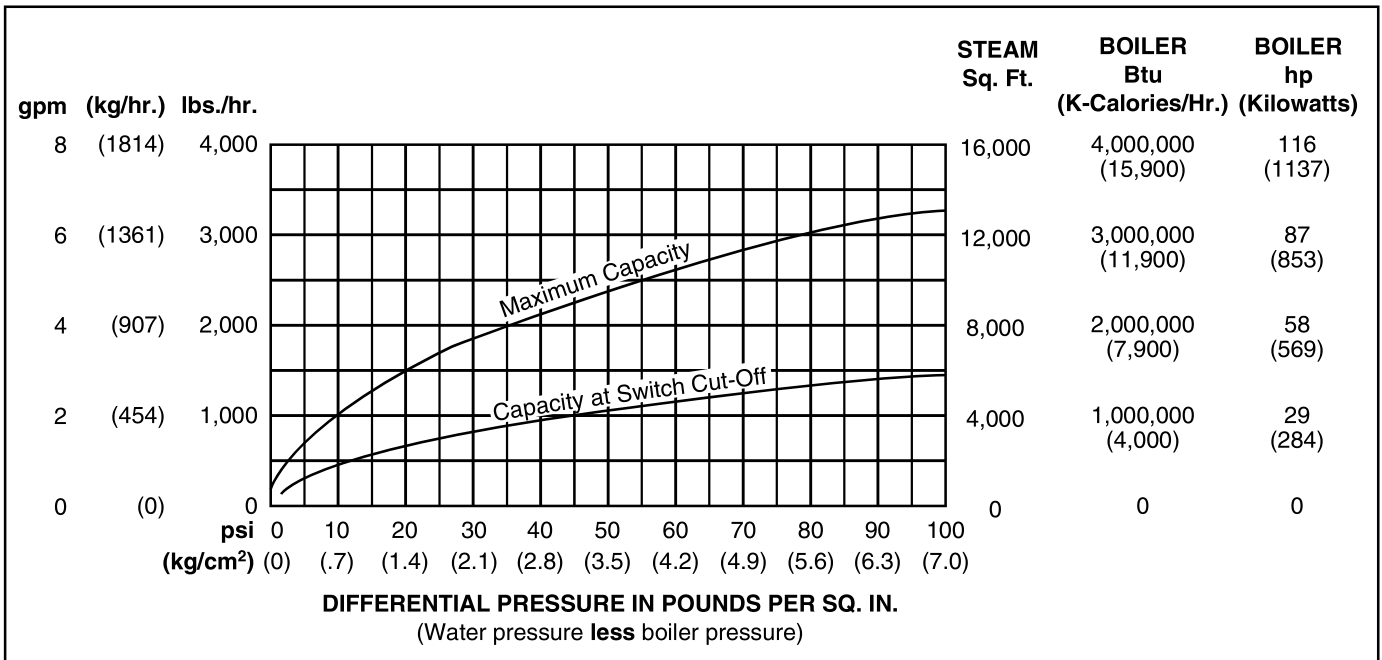

#### Ordering Information

Model Number	Part Number	Description	Weight lbs. (kg)
47	132700	Mechanical water feeder	27.5 (12.5)
47-2	132800	47 w/No. 2 switch	28.5 (13.0)
47-2-M	132900	47-2 w/manual reset	28.5 (13.0)
47-X	133400	47 w/o quick hook-up fittings	25.0 (11.4)
47-2X	176212	47-2 w/o quick hook-up fittings	26.0 (11.8)