

Submersible Effluent Pumps

Specifications:

DISCHARGE	2" NPT, Female, Vertical
LIQUID TEMPERATURE	104°F (40°C) Continuous
MOTOR HOUSING	Cast Iron
PUMP BODY	Cast Iron
IMPELLER: <i>Design</i>	Multi-Vane, Vortex
<i>Material</i>	Cast Iron
SHAFT	420 Stainless Steel
O-RINGS	Buna-N
HARDWARE	300 Series Stainless Steel
PAINT	Air Dry Enamel
SEAL: <i>Design</i>	Single Mechanical, Oil Filled Reservoir
<i>Material</i>	Carbon/Ceramic/Buna-N
	Hardware -300 Series Stainless
CORD ENTRY	10 ft. (3m) Cord with pressure Grommet for sealing and strain relief
UPPER BEARING.....	Single Row, Ball
LOWER BEARING.....	Single Row, Ball
MOTOR: <i>Design</i>	Oil Filled
<i>Insulation</i>	Class B
SINGLE PHASE.....	Permanent Split Capacitor (PSC) Includes Overload Protection in Motor
LEVEL CONTROL:	
SEV412.....	None
SEV412A.....	Wide Angle, Mechanical, 20 ft (6m) cord Pipe Mounted
RECOMMENDED:	
<i>Accessories</i>	Break Away Fitting (BAF) Check Valve Control Panel

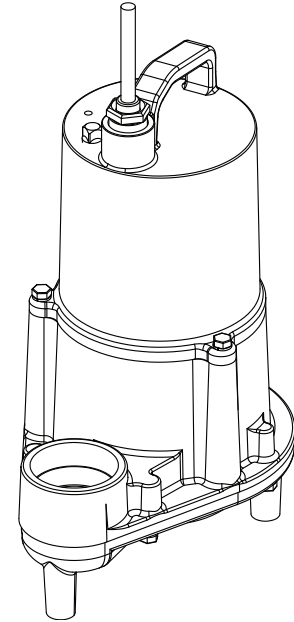

Series: EHV512

.5HP, 3450RPM, 60Hz

DESCRIPTION:

PUMP IS DESIGNED FOR HANDLING SEWAGE EFFLUENT IN TYPICAL SEPTIC TANK/EFFLUENT APPLICATIONS.



WARNING:
CANCER AND REPRODUCTIVE HARM -
WWW.P65WARNINGS.CA.GOV



Series EHV512

3/4" Spherical Solids Handling
Manual & Automatic

BARNES®

www.cranepumps.com

Submersible Effluent Pumps

inches
(mm)

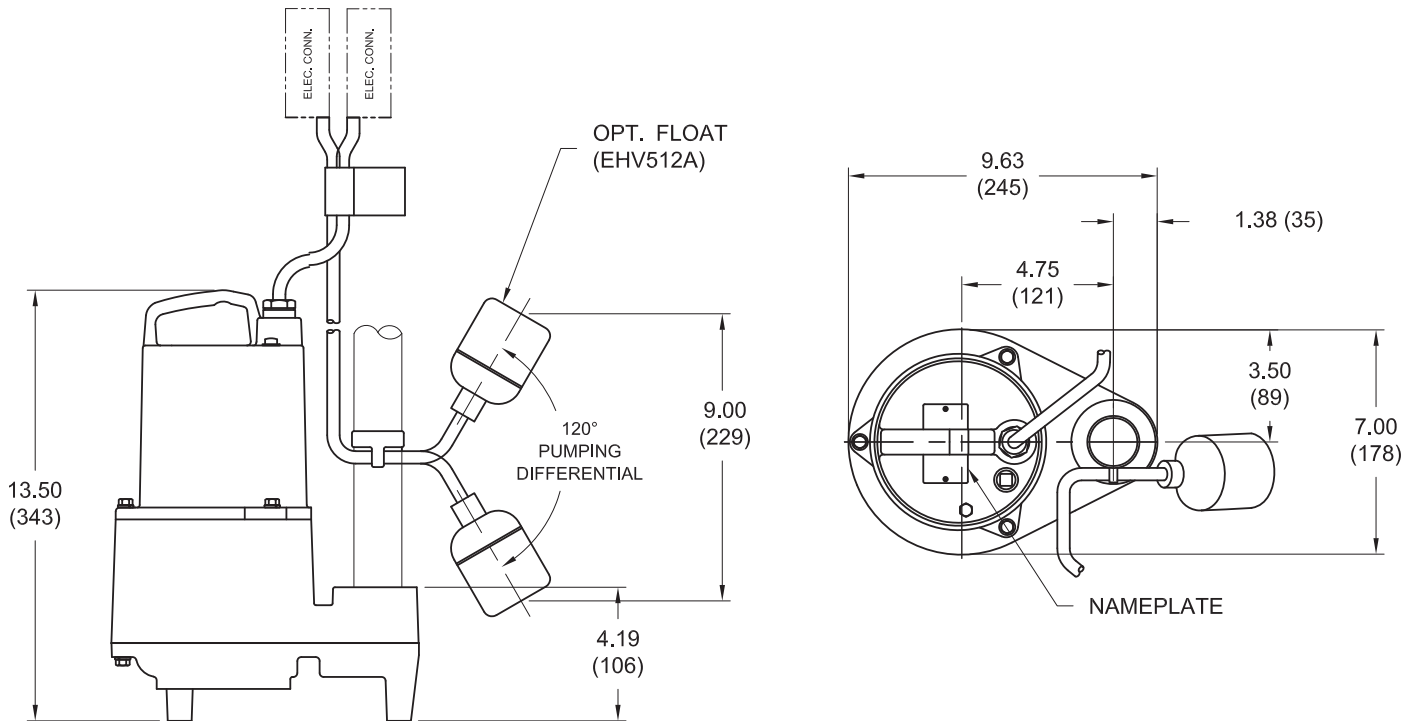

MODEL NO	PART NO	HP	VOLT/PH	Hz	RPM (Nom)	NEMA START CODE	FULL LOAD AMPS	LOCKED ROTOR AMPS	CORD LENGTH	CORD SIZE	CORD TYPE
EHV512	143984	0.5	115/1	60	3450	H	10	19.6	10 ft. (3m)	14/3	SJTOW
EHV512A	143985	0.5	115/1	60	3450	H	10	19.6	10 ft. (3m)	14/3	SJTOW
EHV512	144668	0.5	115/1	60	3450	H	10	19.6	20 ft. (6m)	14/3	SJTOW
EHV512A	144669	0.5	115/1	60	3450	H	10	19.6	20 ft. (6m)	14/3	SJTOW

NOTE: 'A' Suffix has float option.

IMPORTANT !

- 1.) PUMP MAY BE OPERATED "DRY" FOR EXTENDED PERIODS WITHOUT DAMAGE TO MOTOR AND/OR SEALS.
- 2.) INSTALLATIONS SUCH AS DECORATIVE FOUNTAINS OR WATER FEATURES PROVIDED FOR VISUAL ENJOYMENT MUST BE INSTALLED IN ACCORDANCE WITH THE NATIONAL ELECTRIC CODE ANSI/NFPA 70 AND/OR THE AUTHORITY HAVING JURISDICTION. THIS PUMP IS NOT INTENDED FOR USE IN SWIMMING POOLS, RECREATIONAL WATER PARKS, OR INSTALLATIONS IN WHICH HUMAN CONTACT WITH PUMPED MEDIA IS A COMMON OCCURRENCE.

SECTION 3A
PAGE 12
DATE 11/19

CRANE
A Crane Co. Company

PUMPS & SYSTEMS

USA: (937) 778-8947 • Canada: (905) 457-6223 • International: (937) 615-3598

Submersible Effluent Pumps

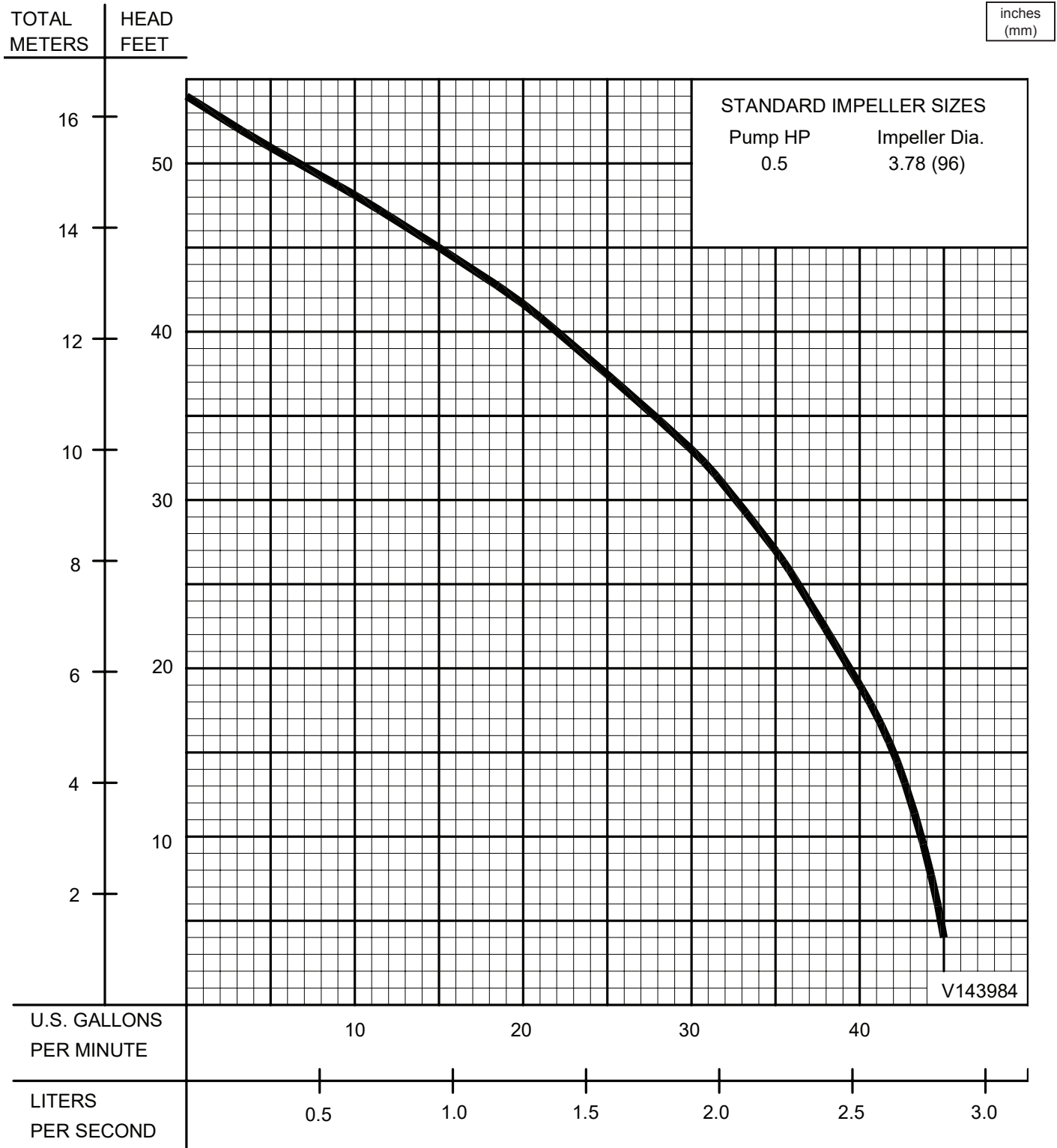

Testing is performed with water, specific gravity 1.0 @ 68° F @ (20°C), other fluids may vary performance