

PRESSURE & TEMPERATURE TRIDICATOR GAUGES



STANDARD FEATURES:

- Choice of 3" or 2 1/2" case.
- 3" is steel case w/stainless connection
- 2 1/2" is stainless case w/brass connection
- Pressure and temperature
- Unique short probe requires minimal depth in process
- Dual English and metric ranges
- Back center mount

SPECIFICATIONS:

Gauge has heavy flat glass lens. Center back connection. Composite length of 1/4" NPT connection and sensor stem is 1.4" max. Sensor stem alone is .633" max.

Pressure gauge accuracy is 3%-2%-3%.
Temperature gauge is accuracy is ±1%.

Pressure Range	Temperature Range	3" Face Part Number	2 1/2" Face Part Number
0-160-PSI	0-180°F	PT160C-3-BK	PT160C-2-1/2-SS

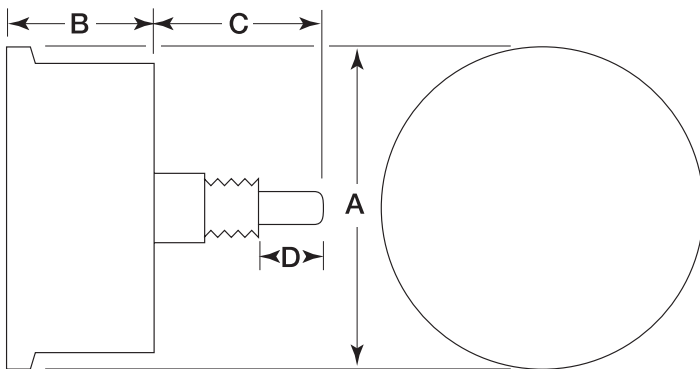

Case	A	B	C	D	Connection
2 1/2"	2 11/16"	1 9/64"	1.4	5/8"	Brass
3"	3 1/4"	1 3/8"	1.4	5/8"	Stainless

JJD

JJ DOWNS INDUSTRIAL PLASTICS INC.



416.236.1884

Toronto, ON

JJDOWNS.COM