

THE STABILIZER

Precise, Dynamic Control of Air-Loaded Regulator

The Stabilizer is a closed-loop, proportional controller. It maintains process liquid pressure at a constant, preset value by modulating air pressure to the regulator. The combination of The Stabilizer and an Air-Loaded Pressure Regulator eliminates the need for an exotic, expensive control valve in most applications.



Superior Features of Series PRS:

- Used with an Air-Loaded Regulator, Series PRS reacts instantly to fluctuations in pressure, significantly enhancing the accuracy of the air-loaded regulator - downstream pressure has virtually no deviation from set pressure.
- Desired pressure is maintained without sacrificing flow. Performance rivals control valves, at much lower cost.
- Ideal for applications with changing pressure requirements.
- Can be conveniently teed into piping at desired control point, or may be mounted at a more convenient location and connected with tubing for process pressure sensing.
- Easy to set; adjustable from 5 PSI to 100 PSI. Maximum pressure at control point is 150 PSI.
- Teflon® diaphragm for critical ultra-pure and corrosive liquid applications.
- No wetted metal or elastomer parts.

Materials of Construction & Piping Connections:

Standard process connection is 1/2" male NPT threaded, for alternate types, consult factory. Standard Air connections are 1/8" female NPT. Connection to regulator valve air chamber should be 1/4" or larger tubing. Air chamber material is PVC. Process connections are available in Grade 1 Type 1 PVC, Natural Polypropylene, Kynar® PVDF and Teflon. Standard seal material is a Teflon diaphragm backed with Viton. Adjusting bolt and external fasteners are stainless steel. A Buna-N rubber seal is used in the air chamber. For materials other than listed, please consult factory.

Performance:

The 1" Air-Loaded Regulator Graph, at right, compares performance with and without *The Stabilizer*. Note that the pressure axis in this graph shows only 16 PSI of the total range; this was done to better illustrate the effectiveness of *The Stabilizer*. With this limited range, however, competitive regulators are below the scale and therefore are not plotted.

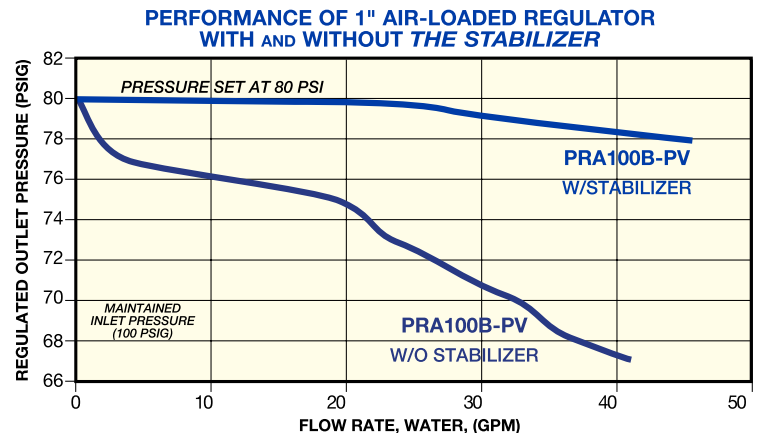

Specifications:

Control Pressure Range:	5 - 100 PSIG (.3 - 6.9 BAR)
Minimum Air Pressure:	Set Pressure + 15 PSI (1.0 BAR)
Maximum Control Point Pressure:	150 PSIG (10.3 BAR)
Air Pressure Ports:	1/8" NPT, female
Process Fluid Port:	1/2" NPT, male
Minimum Process Liquid Supply Pressure:	Set Pressure + All Downstream Pressure Drops to Control Point + 15 PSI

Installation:

The location of *The Stabilizer* should be chosen by the system designer, depending on the application.

1. It may be installed in a tee adjacent to the PRA to regulate pressure immediately downstream.

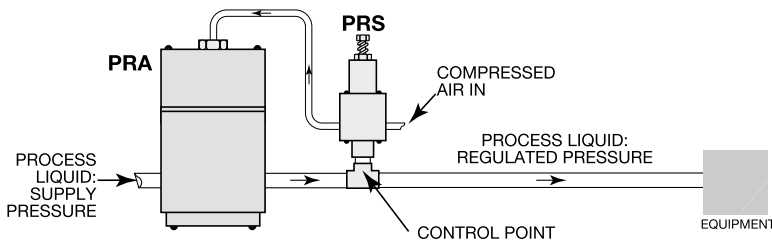

PRS Installed at Point of Maintained Pressure

2. It may be installed downstream, remote of the PRA, if precise regulation is desired at that particular location. This is called the control point. In this case, a sufficient length of air tubing will be required from *The Stabilizer* back to the PRA.

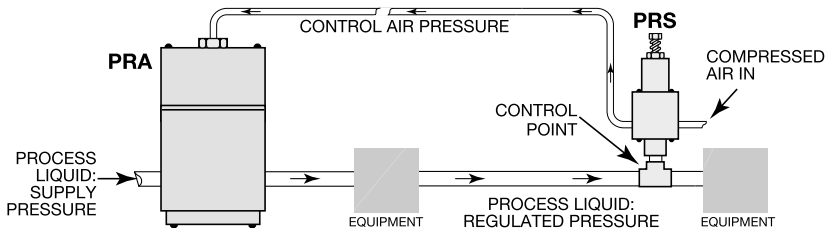

PRS Installed at PRA with Remote Sensing

Other types of remote installations may be designed as required by the application. These may require additional components or other considerations; please consult factory for assistance.

In all cases, the air supplied to *The Stabilizer* should be filtered, lubricated, and regulated. The air chamber vent should be checked periodically to ensure that it is free from debris and permits continuous outflow.

Temperature/Pressure Rating:

Temperature	Max. Air Pressure
77°F (25°C)	125 PSIG (8.6 BAR)
104°F (40°C)	83 PSIG (5.7 BAR)
<i>Max. Operation</i> 140°F (60°C)	33 PSIG (2.5 BAR)
<i>Min. Operation</i> 40°F (5°C)	125 PSIG (8.6 BAR)

Series PRS Model Numbers

Material	Model #
PVC	PRS-T-PV
Natural Polypropylene	PRS-T-PP
Kynar® PVDF	PRS-T-PF
Teflon® PTFE	PRS-T-TF

Model # for standard PRS configurations with Teflon diaphragm and PVC air chamber. For other materials, consult factory.

Series PRS Dimensions:

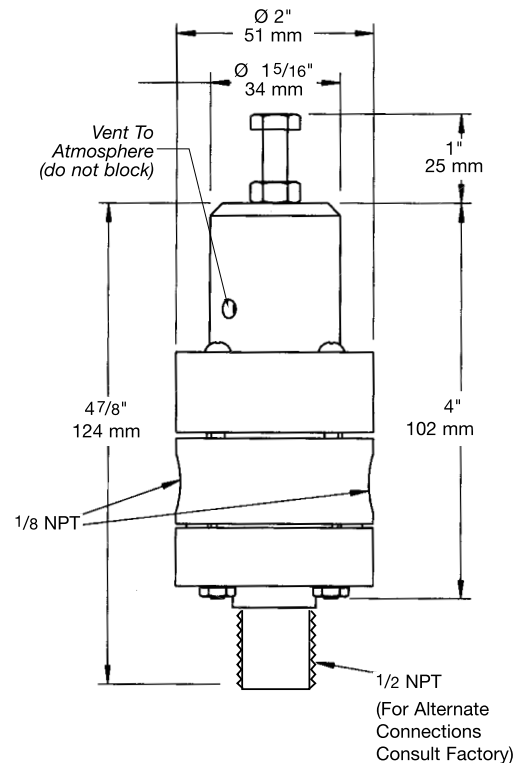

JJD

JJ DOWNS INDUSTRIAL PLASTICS INC.

416.236.1884

Toronto, ON



JJDOWNS.COM