

K4 Butterfly Valve - Lever Handle

POWER
VALVE-CONTROLLED

PPGR(glass reinforced) Body

SIZES: 2-1/2" – 8" (DN65 to DN200)

SEALS: EPDM or Viton

DISC MATERIALS: PVC, CPVC, PP, PVDF

Features:

- Inventory minimized – Stocking one body (PPGR rated at 250°F)
- Lockable 10-position corrosion-resistant handle.
- Double sealed shaft for safety.
- One piece non-wetted 316 stainless steel shaft with engagement over the full length of the disc provides for easy opening and closing and helps prevent blowouts.
- Metal adapter between the handle and shaft avoids abrasion of the handle.
- Integrated ISO actuator mounting pad with stainless steel mounting hardware.
- Interchangeable colour coded ID plates on handles.
- Materials are NSF listed
- CRN No.: 0C13843.5, 0C13843.56



Sample Specifications:

- All K4 series Butterfly valves shall be a wafer type single piece body design rated at 150 psi bubble tight shut off at 70°F/20°C, with non-wetted metal components.
- Bolt hole pattern shall conform to ANSI/ASME B16.5 Class 150 and to DIN-ISO-PN10.
- Valve body shall be molded of PPGR (Polypropylene Glass Reinforced) with disc molded from either PVC-Type I classification 12454, CPVC-Type IV classification 23447, PP-Homopolymere-Beta type cell structure conforming to ASTM D-4101, PVDF-unpigmented conforming to ASTM D-3222.
- Lockable non-corrosive PPGR valve lever type handle shall be provided with each valve, enabling the disc-stem-handle assembly to be locked in each 10 valve indexing positions.
- The shaft shall be a high tensile stainless steel (alternatively Titanium) one piece design having an engagement over the full length of the disc.
- The shaft furthermore be of blowout-proof design.
- Liner and O-Rings seal shall be EPDM (alternatively Viton or specialty EPDM for Chlorine Gas applications).
- EPDM materials shall be in conformance with NSF 61 regulations for potable water and shall be of high tear strength.
- The liner shall have V-notch retention and integrally molded flange face seal to function as a low torque gasket. The material designation (identification) of the liner shall be molded into a visible tab that extends outward.
- All valves shall be engineered and pass pressure tests according to ISO 9393-1, ISO 9393-2:2005(E).
- All hardware shall be of stainless steel grade 316.
- Shaft bearings shall be made from unpigmented PVDF.
- All valves shall have integrated ISO actuator mounting pad with stainless steel mounting hardware.
- The valve handle shall be equipped with double function colour I.D. plates, whereas function one is a colour identification marking device of the process and function two being an environmental cover for handle fastening hardware (316 Stainless Steel).

Options & Accessories:

- Pneumatically or electrically actuated
- Stainless steel shaft extensions
- Stainless Steel lug inserts for dead end service
- Limit switches for open and/or closed position indication

JJD

JJ DOWNS INDUSTRIAL PLASTICS INC.

JJDOWNS.COM

K4 Butterfly Valve with Lever Handle

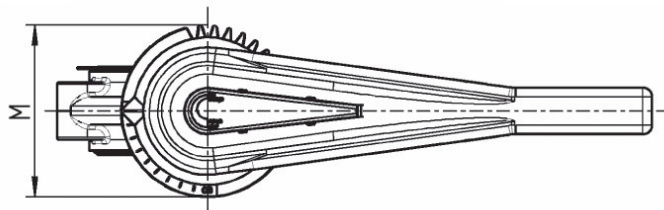
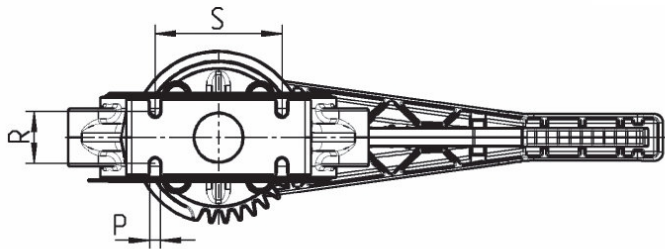
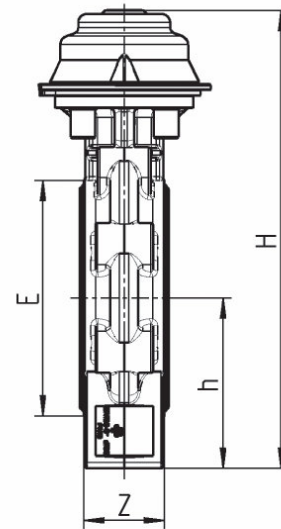
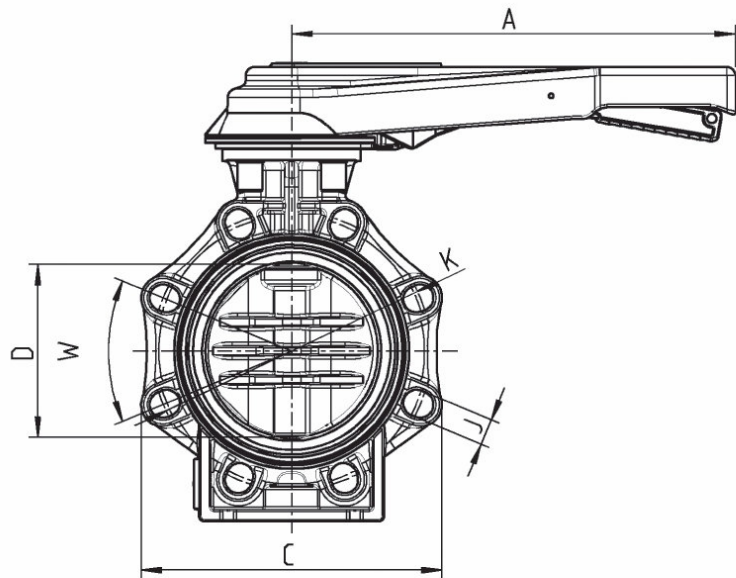

JJD
 JJ DOWNS INDUSTRIAL PLASTICS INC.
 416.236.1884
 JJDOWNS.COM
 Toronto, ON

member
 iapd
 international association
 of plastics distribution

DIMENSIONS: INCHES																		
Size	DN Bore	d	G	A	D	C	W	J	K	H	h	E	M	Z	S	R	P	
2-1/2"	65	75	2-1/2"	9.06	2.56	5.24	90°	0.75	5.00 - 5.71	11.22	3.94	3.86	4.49	1.81	2.16	0.98	0.28	
3"	80	90	3"	9.06	3.15	6.93	45°	0.75	5.75 - 6.30	11.50	3.94	4.57	4.49	1.93	2.76	1.18	0.35	
4"	100	110	4"	11.81	3.94	8.11	45°	0.75	6.89 - 7.50	12.68	4.53	5.75	4.49	2.20	3.35	1.38	0.35	
5"	125	140	5"	11.81	4.92	9.23	45°	0.91	8.25 - 8.50	14.09	5.12	6.69	4.49	2.52	3.94	1.77	0.35	
6"	150	160	6"	15.20	5.91	10.28	45°	0.91	9.23 - 9.50	15.59	5.81	7.72	5.91	2.76	4.33	1.77	0.35	
8"	200	225	8"	15.20	7.87	12.36	45°	0.91	11.42 - 11.75	18.03	6.89	9.88	5.91	2.80	5.71	1.57	0.35	

WEIGHTS: LBS. (EPDM SEAT)			
Size	PVCDisc	CPVCDisc	PP Disc
2-1/2"	3.57	3.49	3.56
3"	2.65	3.64	2.98
4"	5.51	3.90	5.51
5"	7.26	N/A	7.09
6"	10.25	N/A	9.92
8"	15.65	N/A	15.25

WEIGHTS: LBS. (MTON SEAT)				
Size	PVCDisc	CPVCDisc	PP Disc	PVDF Disc
2-1/2"	3.90	3.94	3.88	3.94
3"	3.55	4.45	4.36	3.55
4"	5.51	4.95	4.25	5.51
5"	7.69	N/A	7.52	7.86
6"	9.87	N/A	9.27	9.87
8"	15.87	N/A	15.33	14.03

Torque

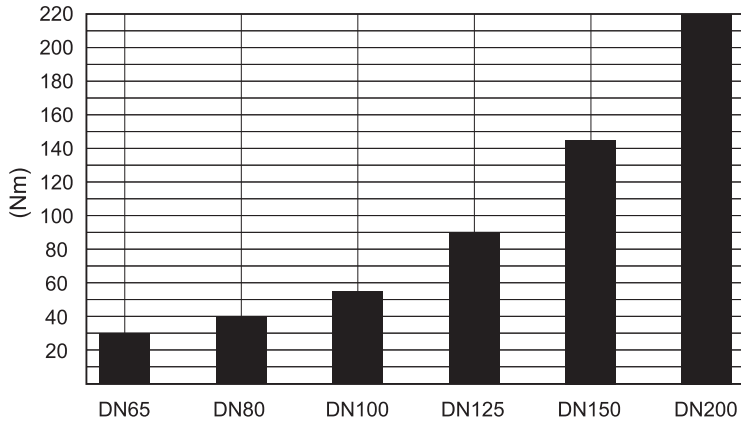

Size	Cv Value	Torque (Inch Lbs.)	Mounting Pad	Stem	Tightening torque of screws for flange connections (Inch Lbs.)
2-1/2"	160	261	F07	11 mm	130
3"	195	348	F07	11 mm	157
4"	571	479	F07	14 mm	174
5"	953	783	F07	14 mm	261
6"	1775	1262	F10	17 mm	348
8"	2645	1914	F10	17 mm	478

Pressure – Temperature

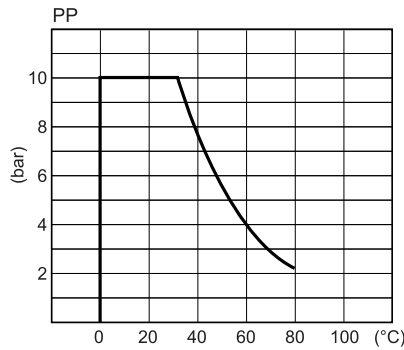
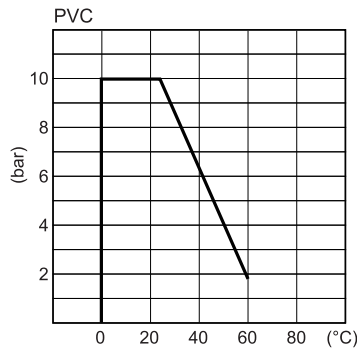

Temperature		WORKING PRESSURES (PSI)			
°C	°F	PVC	CPVC	PP	PVDF
0	32	145	145	145	145
20	68	145	145	145	145
40	104	90	109	113	119
60	140	27	68	57	72
80	176	—	32	31	41
100	220	—	—	—	17

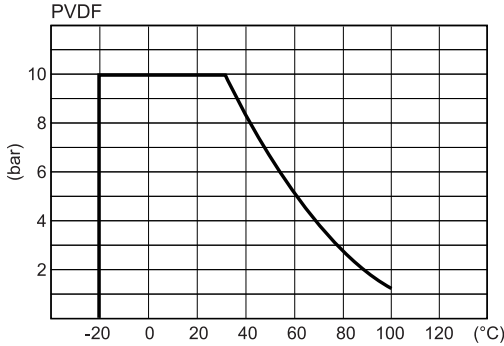
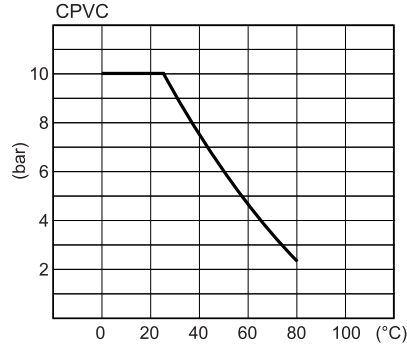

Pressure loss (PVC, PP, PVDF)

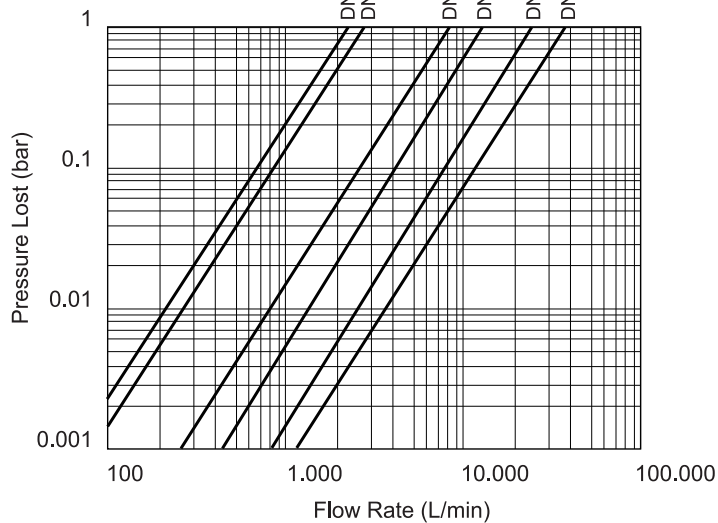

Pressure loss (CPVC)

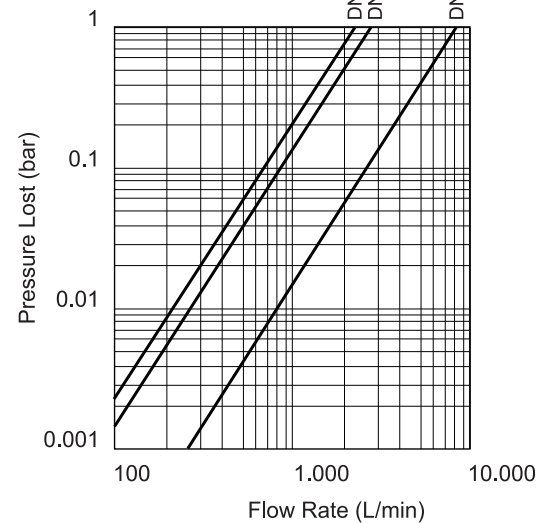

Parts List/Diagram

1. Body
2. Elastomer seat. EPDM or Viton
3. Disc PVC, CPVC, PP, PVDF
4. SS Shaft
5. Shaft O-Ring bottom
6. Shaft O-Ring top
7. Shaft bushing seal
8. Shaft bushing
9. Retaining ring
10. Holding disc
11. Screw
12. Cap
13. Position lock plate
14. Plate screws
15. Washers
16. Plate nuts
17. Plate caps
18. Handle
19. Lever
20. Pin
21. Spring
22. Handle washer
23. Handle bolt
24. I.D. Marking plate

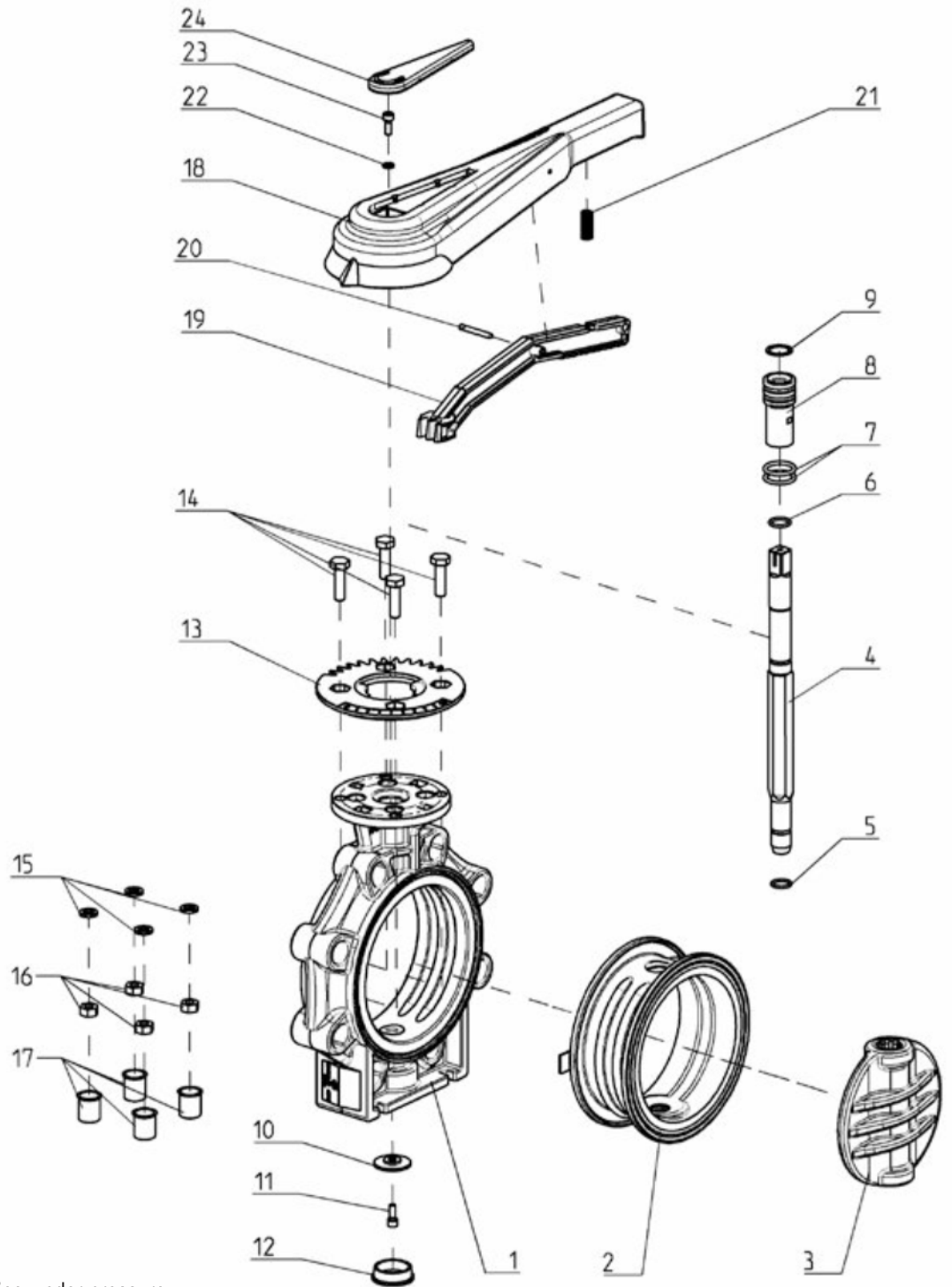

CAUTION:

- Never remove valve from pipeline under pressure.
- Always wear protective gloves and goggles.

JJD

JJ DOWNS INDUSTRIAL PLASTICS INC.



416.236.1884

Toronto, ON

JJDOWNS.COM