

Inch Superseal

JJD

Fluid System Products

Fittings, Valves & Tubing Catalog



How to make a Push-Fit connection

JJD Fluid System Products

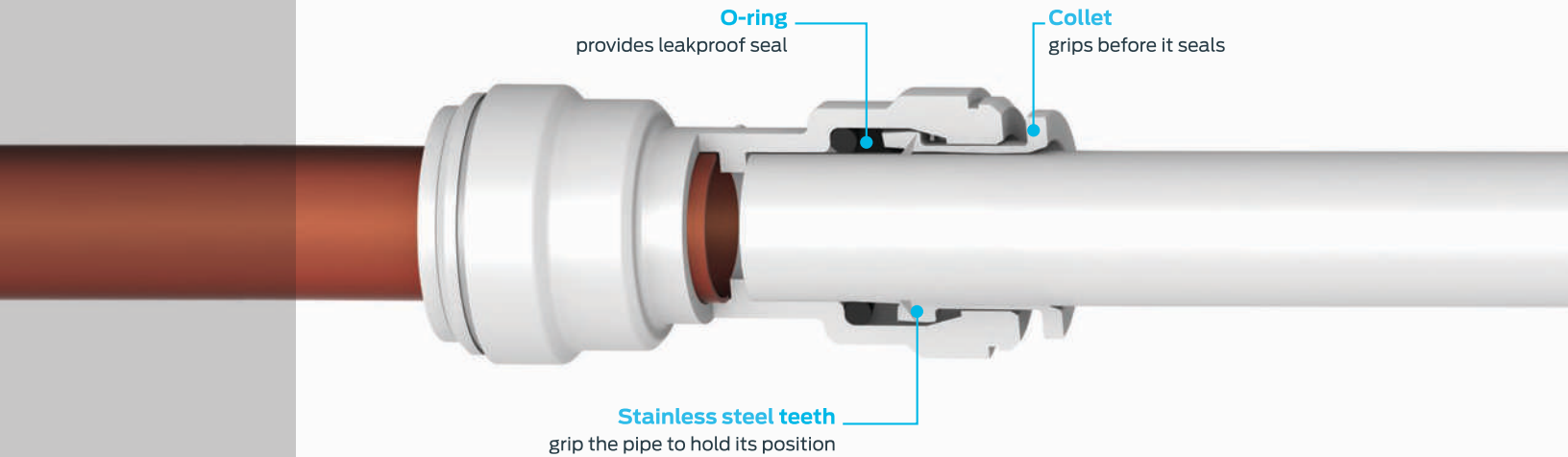

To connect

Keep product clean until ready to use. Always pressure test once installed.



Step 1

Cut the tube square and remove any burrs or score marks. We recommend using a tube insert for soft or thin-walled plastic tubing.



Step 2

Push the tube into the fitting and up to the tube stop.



Step 3

Pull on the tube to check that it is secure. Test the system before use.

To disconnect



Step 1

Make sure that the system is depressurized, then push the collet square against the fitting. With the collet held in this position, the tube can be removed.

JJD

JJ DOWNS INDUSTRIAL PLASTICS INC.

416.236.1884

Toronto, ON



JJDOWNS.COM

Fluid System Fittings Inch Superseal



For use with Stainless Steel Tubing

The SI Range of inch-size push-fit fittings is offered for tube sizes 1/4" OD to 3/8" OD. Superseal is a special fitting designed to provide extra grip on stainless steel tubes. The Superseal design features a collet with integrally molded stainless steel teeth similar to the standard Super Speedfit/Push-Fit design, but incorporates an additional hand-operated nut and wedge-shaped plastic washer to apply extra pressure to the collet and the double O-ring seals. This causes the collet teeth to bite thoroughly into the tube to provide grip, while at the same time, compressing the O-rings to further enhance sealing.

Superseal is suitable for potable liquids and other food quality applications.

Working pressures and temperatures

1/4"- 5/16": Max. 230 psi at 68°F 3/8": Max. 150 psi at 68°F
 Max. 150 psi at 150°F Max. 100 psi at 150°F

For general technical specifications, refer to page 80.

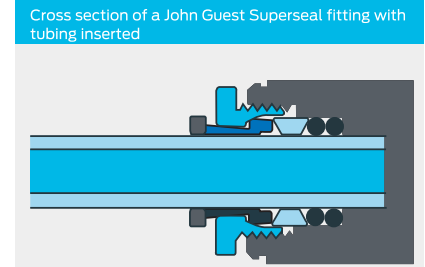

Male Connector
BSPT Thread



Part Number	Superseal OD	Thread BSPT	Bag Qty	Box Qty
SM010802S	5/16"	1/4"	10	200

Male Connector
BSPP Thread



Part Number	Superseal OD	Thread BSPP	Bag Qty	Box Qty
SM010812S	5/16"	1/4"	10	200

Flare Male Connector
MFL Thread



Part Number	Superseal OD	Thread MFL	Bag Qty	Box Qty
SM0108F4S	5/16"	1/4"	10	200

Union Elbow
Superseal - Speedfit



Part Number	Superseal OD	Speedfit OD	Bag Qty	Box Qty
SI030812S	1/4"	3/8"	10	150
SM030808S	5/16"	5/16"	10	200
SI031012S	5/16"	3/8"	10	150
SI031210S	3/8"	5/16"	10	150
SI031212S	3/8"	3/8"	10	150

Union Elbow
Superseal - Superseal



Part Number	Superseal OD	Superseal OD	Bag Qty	Box Qty
SM400808S	5/16"	5/16"	10	150
SI401210S	3/8"	5/16"	10	150
SI401212S	3/8"	3/8"	10	150

Union Connector
Superseal - Speedfit



Part Number	Superseal OD	Speedfit OD	Bag Qty	Box Qty
SM040808S	5/16"	5/16"	10	200
SI041012S	5/16"	3/8"	10	200
SI041016S	5/16"	1/2"	10	200
SI041210S	3/8"	5/16"	10	200
SI041212S	3/8"	3/8"	10	150
SI041216S	3/8"	1/2"	10	150



member
iapd
international association
of plastics distribution

JJ DOWNS INDUSTRIAL PLASTICS INC.

416.236.1884 Toronto, ON JJDOWN.COM

Fluid System Fittings Inch Superseal

JJD Fluid System Products

Union Connector Superseal - Superseal



Part Number	Superseal OD	Bag Qty	Box Qty
SM410808E	5/16"	10	200

Barb Connector



Part Number	Superseal OD	Hose ID	Bag Qty	Box Qty
SI270808S	1/4"	1/4"	10	300
SI271008S	5/16"	1/4"	10	250
SI271208S	3/8"	1/4"	10	200

Flow Bend Connector Superseal - Speedfit



Part Number	Superseal OD	Speedfit OD	Bag Qty	Box Qty
SM420808S	5/16"	5/16"	10	100
SI421012S	5/16"	3/8"	10	100
SI421210S	3/8"	5/16"	10	100
SI421212S	3/8"	3/8"	10	100

Spanner For Superseal Fittings



Part Number	Size	Bag Qty	Box Qty
SPAN1	5/16" & 3/8"	1	100

The Spanner is for use when securing Superseal fittings to stainless steel tubing. One side is for use with a 5/16" Superseal fitting and the other side works with a 3/8" Superseal fitting.



JJ DOWNS INDUSTRIAL PLASTICS INC.



416.236.1884

Toronto, ON

JJDOWNS.COM