

# Variable Area Flow Meters



CRN  
Registered  
Corrosion Chemist

SERIES: FC – Compact – 5" Single Scale  
FS – Full Size – 7" Dual Scale<sup>1</sup>

MATERIALS: Tube: Clear PVC, Polyamide (PA), Polysulfone (PSU) or PVDF<sup>2</sup>  
Float: PVDF  
Ends: PVC, CPVC, PP, PVDF, Socket, Threaded, Flanged, Butt or ChemFlare™<sup>3</sup>

O-RINGS: EPDM, FPM (Viton®)

CAPACITIES: Up to 220 USGPM (50,000 litres per hour)



F Series Variable Area Flow Meters are ideal for plastic piping. They provide a combination of accurate visual flow rate measurement and clear flow indication from a distance. Optional limit switches allow the units to signal a low or high flow alarm. An optional flow transmitter provides a 4 to 20 mA signal output. These flow meters must be installed vertically with flow upward.

## Features

### Clear Visual Indication

- Large orange float is visible from a distance
- Range indicators slide along dovetail track

### Easy Installation and Maintenance

- Just unscrew union nuts and tube slides out of line

### Choice of Four Tube Materials for Many Applications:

- **Clear PVC** – For Water or Chemicals up to 60°C (140°F) – High Chemical resistance at low cost
- **Polyamide (PA)** – For Water or Air up to 75°C (167°F) – High impact strength and optical clarity
- **Polysulfone (PSU)** – For Chemicals and Gases up to 100°C (212°F) – High impact strength and good chemical resistance
- **PVDF<sup>2</sup>** – For Chemicals and Ultrapure fluids up to 110°C (230°F) – High impact strength and excellent chemical resistance.

### Ideal for All Types of Plastic Piping

- All types of end connections in PVC, CPVC, PP & PVDF

### Low Pressure Drop

### Good Measuring Accuracy – Class IV

- ± 3% of indicated value, plus ± 1% of full scale.
- Read scale at top (largest diameter) of float

### Non Fouling

- Float is self supporting in the flow. No guide rod (which can cause the float to jam) is necessary.

### CRN Registration numbers by province

- Ontario: OF10134.5
- Newfoundland: OF10134.50
- Alberta: OF10134.52
- Saskatchewan/Manitoba/Quebec: OF10134.56
- New Brunswick: OF10134.57
- Nova Scotia: OF10134.58
- P.E.I.: OF10134.59
- British Columbia: not required

<sup>1</sup> USGPM and litres per hour (water) scale is supplied as standard on full size meters.

<sup>2</sup> Because PVDF is translucent, a magnetic float and limit switches are usually used.

JJ DOWNS INDUSTRIAL PLASTICS INC.

JJDOWNS.COM

# Variable Area Flow Meters

## NOTES:

PVDF flow meters are available in all sizes. Change third letter in item number to K.

<sup>1</sup> ΔP = Pressure loss through flow meter with water at 20°C (68°F).

<sup>2</sup> Dimension L is for PVC Socket ends.

## FC SERIES – COMPACT SIZE – 5" SCALE

Single USGPM (water) scale is supplied standard

End Conn. Size	Item Number			Flow Range (water)		Dimensions (inches)			Pressure Drop (psi) <sup>1</sup>	
	PVC Tube	Polyamide Tube	Polysulfone Tube	USGPM	Litres per hour	A	L <sup>2</sup>	D	Water	Air
3/8"	FCA00020	FCT00020	FCP00020	0.0132 – 0.106	3 – 24	6.50	8.2	1.38	0.05	0.07
	FCA00060	FCT00060	FCP00060	0.022 – 0.264	5 – 60	6.50	8.2	1.38	0.05	0.07
	FCA00100	FCT00100	FCP00100	0.04 – 0.44	10 – 100	6.50	8.2	1.38	0.05	0.07
	FCA00250	FCT00250	FCP00250	0.11 – 1.10	25 – 250	6.50	8.2	1.38	0.05	0.07
1/2"	FCA00051	FCT00051	FCP00051	0.02 – 0.22	5 – 50	6.69	8.7	1.69	0.04	0.06
	FCA00151	FCT00151	FCP00151	0.07 – 0.66	15 – 150	6.69	8.7	1.69	0.04	0.06
	FCA00251	FCT00251	FCP00251	0.11 – 1.10	25 – 250	6.69	8.7	1.69	0.04	0.06
	FCA00401	FCT00401	FCP00401	0.18 – 1.76	40 – 400	6.69	8.7	1.69	0.04	0.06
3/4"	FCA00152	FCT00152	FCP00152	0.07 – 0.66	15 – 150	7.28	9.6	2.09	0.09	0.12
	FCA00402	FCT00402	FCP00402	0.22 – 1.76	40 – 400	7.28	9.6	2.09	0.09	0.12
	FCA00602	FCT00602	FCP00602	0.26 – 2.64	60 – 600	7.28	9.6	2.09	0.09	0.12
	FCA01002	FCT01002	FCP01002	0.44 – 4.40	100 – 1,000	7.28	9.6	2.09	0.09	0.12
1"	FCA00253	FCT00253	FCP00253	0.11 – 1.10	25 – 250	7.87	10.5	2.36	0.09	0.12
	FCA00403	FCT00403	FCP00403	0.18 – 1.76	40 – 400	7.87	10.5	2.36	0.09	0.12
	FCA01003	FCT01003	FCP01003	0.44 – 4.40	100 – 1,000	7.87	10.5	2.36	0.09	0.12
	FCA01503	FCT01503	FCP01503	0.66 – 6.60	150 – 1,500	7.87	10.5	2.36	0.09	0.12

## FS SERIES – STANDARD FULL SIZE – 7" SCALE

Dual USGPM (water) and litres per hour scales are supplied standard

End Conn. Size	Item Number			Flow Range (water)		Dimensions (inches)			Pressure Drop (psi) <sup>1</sup>	
	PVC Tube	Polyamide Tube	Polysulfone Tube	USGPM	Litres per hour	A	L <sup>2</sup>	D	Water	Air
1"	FSA00600	FST00600	FSP00600	0.26 – 2.64	60 – 600	13.78	16.3	2.36	0.18	0.23
	FSA01000	FST01000	FSP01000	0.44 – 4.40	100 – 1,000	13.78	16.3	2.36	0.18	0.23
1-1/4"	FSA01500	FST01500	FSP01500	0.66 – 6.60	150 – 1,500	13.78	16.6	2.83	0.18	0.23
	FSA02500	FST02500	FSP02500	1.10 – 11.00	250 – 2,500	13.78	16.6	2.83	0.18	0.23
1-1/2"	FSA02000	FST02000	FSP02000	0.88 – 8.80	200 – 2,000	13.78	16.8	3.27	0.18	0.23
	FSA03000	FST03000	FSP03000	1.32 – 13.20	300 – 3,000	13.78	16.8	3.27	0.18	0.23
2"	FSA04000	FST04000	FSP04000	1.76 – 17.60	400 – 4,000	13.78	17.2	4.06	0.32	0.39
	FSA06000	FST06000	FSP06000	2.64 – 26.40	600 – 6,000	13.78	17.2	4.06	0.32	0.39
	FSA10000	FST10000	FSP10000	4.40 – 44.00	1,000 – 10,000	13.78	17.2	4.06	0.32	0.39
2-1/2"	FSA15000	FST15000	FSP15000	6.60 – 66.00	1,500 – 15,000	13.78	17.7	4.80	0.49	0.58
	FSA25000	FST25000	FSP25000	11.00 – 110.00	2,500 – 25,000	13.78	17.7	4.80	0.49	0.58
	FSA50000	FST50000	FSP50000	44.00 – 220.00	10,000 – 50,000	13.78	17.7	4.80	0.49	0.58

## CONVERSION CHART – FLOW UNITS

From	To	m <sup>3</sup> /hr	litres/hr	USGPM	ImpGPM	ft <sup>3</sup> /min
m <sup>3</sup> /hr		1	1000	4.4029	3.6662	0.5886
litres/hr		0.001	1	.004403	.003666	.000589
USGPM		0.2271	227.12	1	0.8327	0.1337
ImpGPM		0.2728	272.77	1.2009	1	0.1605
ft <sup>3</sup> /min		1.6990	1699	7.4806	6.2289	1

Values based on water at 20°C (68°F).

JJ DOWNS INDUSTRIAL PLASTICS INC.

**JJDOWNS.COM**

# Variable Area Flow Meters

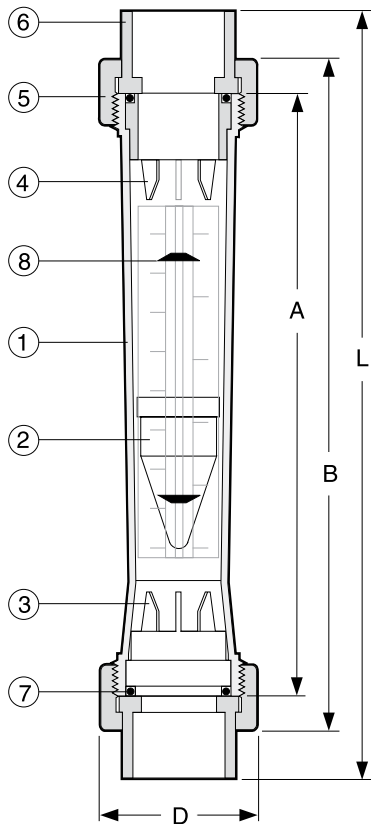

## PARTS

▲ Recommended Spare Parts

No.	Part	Pcs.	Materials
1	Tube	1	Polyamide (PA), Polysulfone (PSU), Clear PVC, PVDF
2	Float	1	PVDF (standard or magnetic)
3	Lower Float Stop	1	PVDF
4	Upper Float Stop	1	PVDF
5	Union Nut	2	PVC, PPG, PVDF
6	End Connector	2	PVC, CPVC, PP or PVDF
7▲	O-Rings	2	EPDM, FPM(Viton®)
8▲	Range Indicator	2	ABS

## ACCESSORIES

- **Limit Switches** – One switch for both maximum or minimum. A magnetic float is required.
- **Switch Ratings** – P (max) = 10 VA, E (max) = 470VAC, I (max) = 0.5A
- **Throttling Valve** for flow control
- **4–20 mA Output Signal Unit** must be factory calibrated for specific service

## OPTIONS

- **Custom Direct Reading Scale** for services other than water
- **Alternate O-Rings** – ie. FPM (Viton®)
- **End Size Reduction** – Accuracy is not significantly affected by end reduction
- **Other Ends** – Threaded, socket or flanged end connections in PVC, CPVC, PP or PVDF. Butt ends in PP or PVDF.

## MAXIMUM WORKING PRESSURES AND TEMPERATURE RANGES

Construction (‡ = Optional Materials)				Maximum	
Tube	O-Rings	Union Nuts	Ends	Pressure <sup>2</sup>	Temperature Range
PVC	EPDM	PVC	PVC	150 psi	0 to 60°C (32 to 140°F)
Polyamide (PA)	EPDM	PVC	PVC	150 psi	0 to 60°C (32 to 140°F)
Polyamide (PA)	EPDM	PPG‡	PP or CPVC‡	150 psi	0 to 75°C (32 to 167°F)
Polysulfone (PSU)	EPDM	PVC	PVC	150 psi	0 to 60°C (32 to 140°F)
Polysulfone (PSU)	EPDM	PPG‡	PP or CPVC‡	150 psi	0 to 90°C (32 to 194°F)
PVDF	FPM(Viton®)	PVDF	PVDF	150 psi	-40 to 110°C (-40 to 230°F)

<sup>2</sup>150 psi is not recommended at maximum temperatures.

## recommended installation

To avoid vibration of the float, recommended installation is 10 diameters of straight pipe before and 5 diameters after the flow meter.

## flow meter sizing – liquid flow

Standard Scale values are for clean water flow at 20°C (68°F). For liquids with densities and viscosities similar to water (ie. specific gravity of 1.0 and viscosities between 0.5 cP and 1.3 cP) the standard water scale will be accurate enough.

The table below shows correction factors to be applied for liquids with specific gravities other than 1.0. Multiply the correction factor by the water scale value to obtain actual flow rate. Example: For a liquid of specific gravity of 1.66, the correction factor is 0.740. For water flow range of 100 to 1000 litres/hr, corrected range becomes 74 to 740 litres/hr. Viscosity should be between 0.5 cP and 1.3 cP for standard scales to be accurate.

For “sizing” liquid flows ie. determining actual flow range of a tube, please advise the **chemical name, concentration, temperature, specific gravity** and **viscosity**. Custom direct reading scales in any units are available special order.

## SCALE CORRECTION FACTORS – FOR LIQUIDS WITH SPECIFIC GRAVITIES OTHER THAN 1.00

Specific Gravity	.00	.01	.02	.03	.04	.05	.06	.07	.08	.09
	<b>Scale Correction Factor</b>									
0.4	1.647	1.626	1.605	1.585	1.565	1.548	1.529	1.513	1.495	1.479
0.5	1.462	1.447	1.433	1.418	1.404	1.391	1.377	1.364	1.351	1.339
0.6	1.326	1.316	1.304	1.292	1.282	1.271	1.259	1.250	1.239	1.229
0.7	1.220	1.211	1.202	1.192	1.183	1.175	1.167	1.157	1.149	1.142
0.8	1.134	1.125	1.117	1.111	1.104	1.096	1.089	1.082	1.075	1.068
0.9	1.062	1.055	1.048	1.042	1.035	1.030	1.024	1.017	1.011	1.005
1.0	1.000	0.994	0.988	0.982	0.978	0.972	0.967	0.962	0.956	0.951
1.1	0.947	0.943	0.936	0.932	0.927	0.923	0.917	0.913	0.909	0.904
1.2	0.900	0.895	0.891	0.887	0.883	0.878	0.874	0.870	0.866	0.862
1.3	0.858	0.854	0.850	0.846	0.842	0.838	0.835	0.831	0.827	0.824
1.4	0.820	0.818	0.814	0.810	0.806	0.803	0.800	0.797	0.794	0.791
1.5	0.787	0.784	0.781	0.778	0.776	0.773	0.770	0.767	0.764	0.759
1.6	0.756	0.754	0.751	0.748	0.745	0.742	0.740	0.737	0.734	0.730
1.7	0.728	0.726	0.723	0.720	0.717	0.714	0.712	0.709	0.706	0.704
1.8	0.701	0.699	0.696	0.694	0.691	0.689	0.686	0.684	0.682	0.679
1.9	0.677	0.674	0.672	0.669	0.667	0.665	0.663	0.661	0.658	0.657
2.0	0.654	0.652	0.650	0.648	0.646	0.644	0.641	0.604	0.637	0.636

# Variable Area Flow Meters

## flow meter sizing – gas flow

**FLOW RANGES FOR AIR** – AT STANDARD CONDITIONS (atmospheric pressure 14.7 psia/20°C).

### FC SERIES – COMPACT SIZE – 5" SCALE

Flow Meter Item No.	Normal m <sup>3</sup> /hr	Standard CFM
FCT00020	0.2 – 1.0	0.1 – 0.6
FCT00060	0.2 – 2.5	0.1 – 1.5
FCT00100	0.6 – 3.6	0.4 – 2.1
FCT00250	0.5 – 9.0	0.3 – 5.3
FCT00051	0.4 – 2.8	0.2 – 1.6
FCT00151	0.8 – 6.2	0.5 – 3.6
FCT00251	0.9 – 9.5	0.5 – 5.6
FCT00401	2.0 – 15.0	1.2 – 8.8
FCT00152	0.5 – 5.5	0.3 – 3.2
FCT00402	2.0 – 14.0	1.2 – 8.2
FCT00602	2.5 – 22.0	1.5 – 12.9
FCT01002	4.0 – 34.0	2.4 – 20.0
FCT00253	1.0 – 8.0	0.6 – 4.7
FCT00403	2.0 – 14.0	1.2 – 8.2
FCT01003	4.0 – 34.0	2.4 – 20.0
FCT01503	5.0 – 50.0	2.9 – 29.4

### FS SERIES – STANDARD FULL SIZE – 7" SCALE

Flow Meter Item No.	Normal m <sup>3</sup> /hr	Standard CFM
FST00600	2.5 – 20	1.5 – 12
FST01000	4 – 34	2.4 – 20
FST01500	5 – 50	2.9 – 29
FST02000	8.5 – 76	5.0 – 45
FST02500	8 – 70	4.7 – 41
FST03000	10 – 90	5.9 – 53
FST04000	14 – 125	8.2 – 74
FST06000	22 – 190	13 – 112
FST10000	35 – 300	21 – 177
FST15000	50 – 500	29 – 294
FST25000	80 – 720	47 – 424
FST50000	400 – 1,500	234 – 883

### SCALE CORRECTION FACTORS – FOR AIR AT NON-STANDARD TEMPERATURES AND PRESSURES

Air density is dependent on the actual pressure and temperature. Calculate the Scale Correction Factor using either Method 1 or 2. Multiply the standard air flow ranges above by the Factor to obtain actual flow rates.

#### Method 1

Calculate the Factor with the following formula.

$$\text{Factor} = \frac{1}{3.7005} \sqrt{\frac{\text{psia}}{(1+0.00367t)}}$$

- psia = pressure of the air absolute
- = psig + 14.7 (atmospheric pressure = 14.7 psia)
- t = temperature of the air °C

#### Method 2

Calculate the density of the air at conditions and find factor from the chart below.

$$\text{Air Density (g/ml)} = \frac{\text{psia}}{11,360 (1+0.00367t)}$$

- psia = pressure of the air absolute
- = psig + 14.7 (atmospheric pressure = 14.7 psia)
- t = temperature of the air °C

**Air Density vs. Flow Factor**

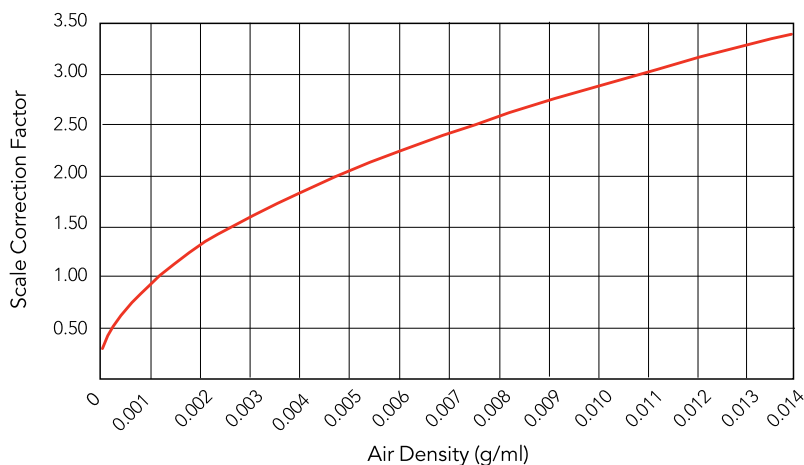

**Temperature vs. Pressure**

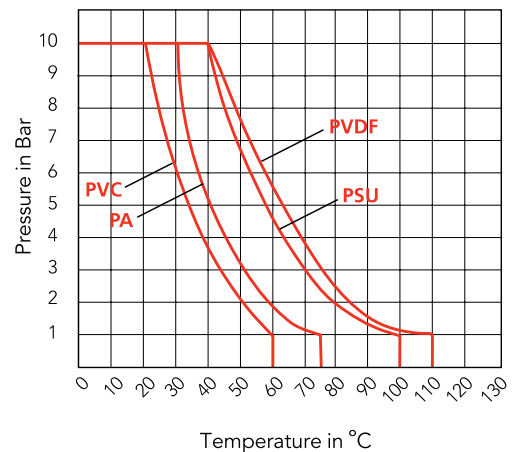

# LSFLO Reed Limit Switch



## for FC & FS flow meters

The **LSFLO** limit switches serve as switches for minimum or maximum flow values. The normally open latching reed switch closes when the float in the measuring tube reaches and exceeds the switching position. The switch condition is maintained as long as the float is above the limit switch and will open when the float in the tube drops below the switch. Normally closed switches are available on request.

## technical

- **Operating voltage:** maximum 230 VAC
- **Operating current:** maximum 0.5 A
- **Constant current when switched:** maximum 1 A
- **Rupturing capacity:** maximum 10 W/10 VA
- **Closed resistance:** < 150 m $\Omega$
- **Open resistance:** > 10<sup>10</sup>  $\Omega$
- **Operating temperature:** 0°C(32°F) to 55°C(131°F)
- **Protection:** IP 65 (DIN 40050)
- **Plug Socket:** DIN EN 175301-803
- **Cable Feed Through:** 4 to 6mm
- **Hysteresis (switch on and off point):** 3 mm
- **Protection:** IP 65 (DIN EN 60528)
- **Dimensions:** 34 x 17 x 41 mm
- **Weight (with plug):** 40 g
- **Connections:** the polarity of the connections has no influence on the function

## INSTALLATION

Screw clamps are used to fit the LSFLO on the dovetail guide of the flow meter.



## CONNECTIONS

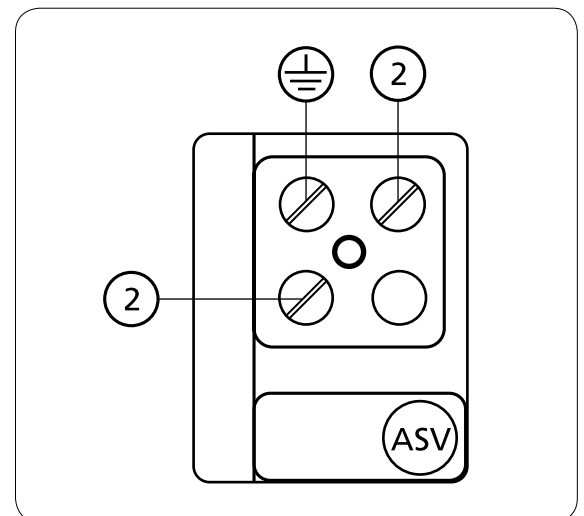

## START-UP

Prior to the first start up it is important that the float passes the LSFLO switch three times to ensure the electronics inside recognize the magnetic field from the floats properly.

# JJD

JJ DOWNS INDUSTRIAL PLASTICS INC

416.236.1884

JJDOWNS.COM

Toronto, ON



# ZE3000 Flow Transmitters



## for FS flow meters

The **ZE3000** flow transmitter provides a 4–20 mA output signal, generated by detection of the position of the magnetic float.

**IMPORTANT:** This micro-processor controlled unit is factory calibrated and unique to each flowmeter model. Flowmeter model must be advised when ordering.

## technical

- **2-Wire technology**
- **4–20 mA analog output** (4-20.1 for 8 VDC supply; 4-22.0 for 28 VDC supply)
- **8–28 VDC input**
- **Factory calibrated (flow meter to be specified when ordering)**
- **11 point calibration**
- **Non-volatile value storage**
- **0 Button to compensate for the surrounding magnetic influences**
- **Factory setting of the lower limit value (low-cut-off) 0-99% according to customer's specifications**
- **Factory time lag (low-pass filter) 0.1-2.5 sec. according to customer's specifications**
- **Measuring accuracy: < 0.5%**
- **Temperature range: -30°C(-20°F) to 65°C(150°F)**

## INSTALLATION

Screw clamps are used to fit the ZE3000 on the dovetail guide of the flow meter.

During installation, ensure that the notch of the ZE3000 coincides with the 50% mark on the flow meter scale.

Following this, proceed with the wiring according to the diagram.

## WIRING

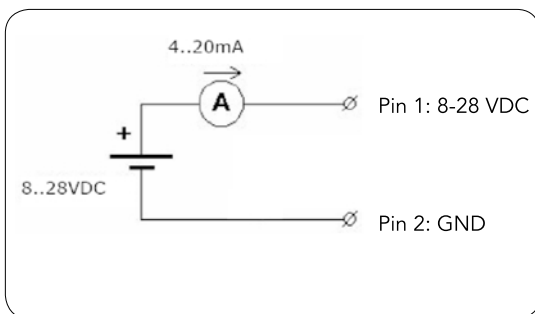

## DIMENSIONS

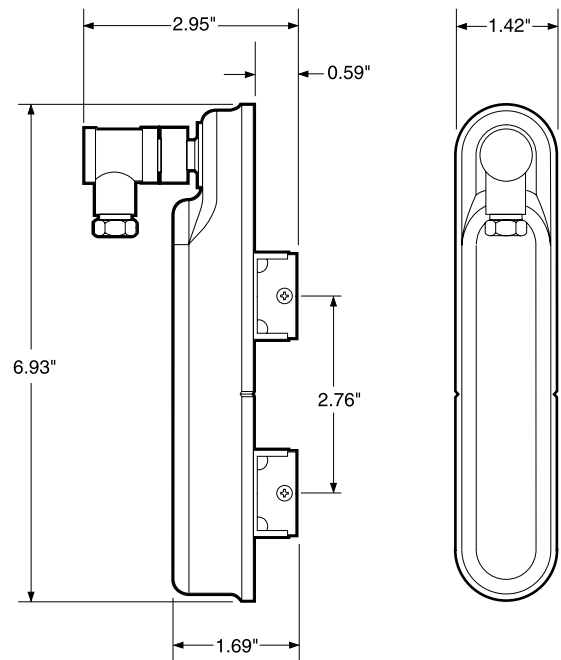

## START-UP

After installation and wiring, press the 0 button for at least 2 sec. to compensate for possible electro-magnetic interference. During this time make sure the float is at the bottom of the flowmeter (ie. no flow condition).

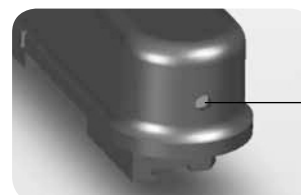

Concealed  
0 button

## Note:

Do not press button during normal operation.





## for FC flow meters

The **ZE3075** flow transmitter provides a 2-wire 4–20 mA output signal omit generated by precise detection of the position of the magnetic float.

The magnetic float travels along the reed chain of switches activating them.

This micro-processor controlled unit is field calibrated.

## technical

- **2-Wire technology**
- **4–20 mA analog output** (4-20.1 for 8 VDC supply; 4-22.0 for 28 VDC supply)
- **18–30 VDC input**
- **Field calibration**
- **Non-volatile value storage**
- **Measuring length:** 114 mm (4.5")
- **Measuring resolution:** 3.5 mm (0.138")
- **Measuring accuracy:** 3%
- **Temperature range:** –20°C(–4°F) to 70°C(158°F)

## INSTALLATION

Screw clamps are used to fit the ZE3075 on the dovetail guide of the flow meter.

During installation, ensure that the top and bottom notches of the ZE3075 coincide with the 10% and 100% marks on the flow meter scale.

Following this, proceed with the wiring according to the diagram.

## WIRING

The unit is connected with a commercially available unshielded cable.

Where electro-magnetic interference is to be expected, we recommend the use of a shielded cable.

Cable cross section: max. 0.75 mm<sup>2</sup> cable outer diameter: 6 to 8 mm.

## Flange Connector

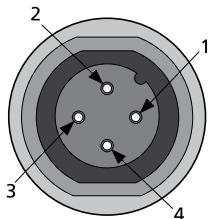

1. Signal (+)
2. Signal (+)
3. n.c.
4. n.c.

## Circuit Diagram

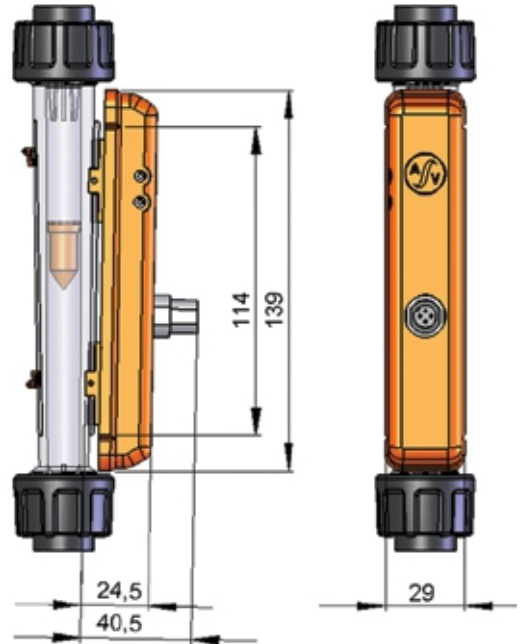
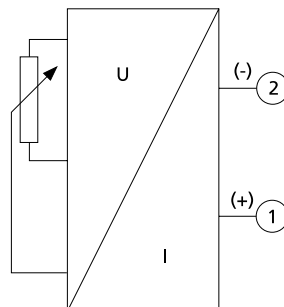

## COMPONENTS

1. Alignment notches for the proper location of the transmitter
2. Potentiometer for the upper limit value of the output signal
3. Potentiometer for the lower limit value of the output signal
4. Plug connector

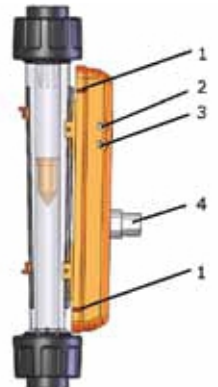

## CALIBRATION

Compensation between the non-linear scaling of the flowmeter and the linear output signal of the flow data sensor must be performed by adjusting, preferably between 20% and 80% of the flow rate.

20% corresponds to 7.2mA and 80% to 16.8mA.

- Connect the amperemeter and the respective voltage supply to the flow data sensor
- Allow 20% of the flow to pass through the FC flow meter
- Set the min. trimmer potentiometer (3) such that the corresponding current (7.2mA) is shown in the amperemeter
- Allow 80% of the flow to pass through the FC flow meter
- Set the max. trimmer potentiometer (3) such that the corresponding current (16.8mA) is shown in the amperemeter
- Check the values at 20% and 80% several times and repeat the adjustment, if required